

RoHS

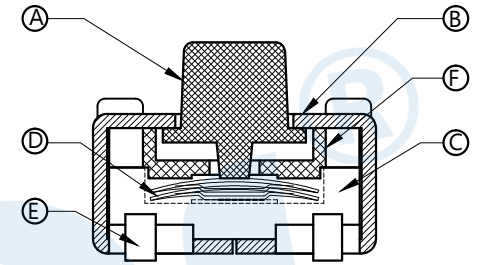
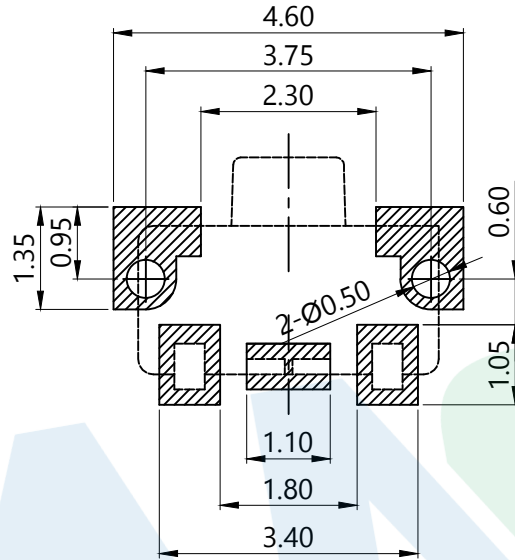
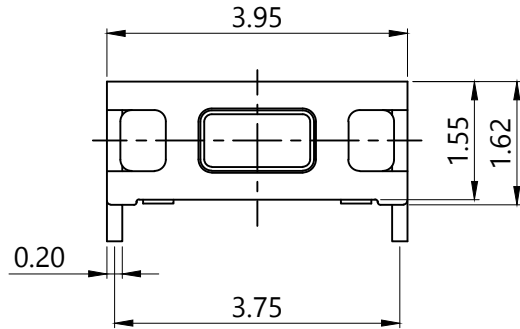

PCB Layout(Pattern side)

SHRAPNEL	
CODE	MATERIAL/QTY
D2	SUS/1PCS
D4	SUS/2PCS

OPERATING FORCE	
CODE	VIGOR
B2	160±30gf

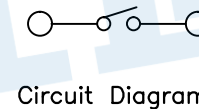
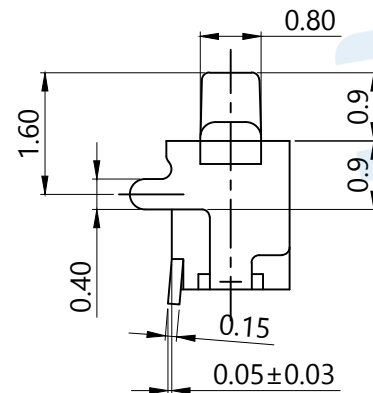
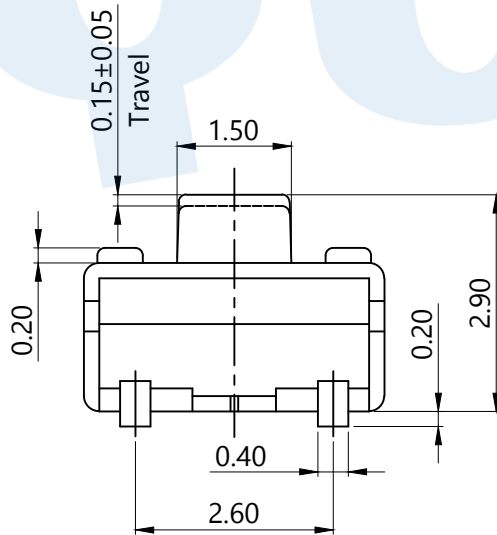

NO.	Name	Number	Qty	Materil	Remarks
⑥	Cover B		1	LCP	White
⑤	Terminal		2	Phosphor Bronze	Plating silver
④	Contact		2	SUS	Plating silver
③	Base		1	LCP	White
②	Cover A		1	Brass	Plating silver
①	Knob		1	LCP	Black

YUANDI® Yuandi Electronics Co., Ltd

design	date	name	TACT SWITCHS
Review	date	name	TS-1042-B□D□
Approved	date	name	

Drawing number: Proportion 1:1 unit mm gage number A4

modify Review Approved Tolerance not specified

angle	±2'
10~30	±0.30
5~10	±0.20
~ 5	±0.10