ML610Q359/ML610Q360

8-bit Microcontroller with Voice Output Function

GENERAL DESCRIPTION

Equipped with a 8-bit CPU nX-U8/100, the ML610Q359 is a high-performance 8-bit CMOS microcontroller that integrates a wide variety of peripherals such as, 12-bit A/D converter, timer, synchronous serial port, UART, and voice output function. The nX-U8/100 CPU is capable of executing instructions efficiently on a one-instruction-per-clock-pulse basis through parallel processing by the 3-stage pipelined architecture.

In addition, it has an on-chip debugging function, which allows software debugging/rewriting with the LSI mounted on the board.

FEATURES

- CPU
 - 8-bit RISC CPU (CPU name: nX-U8/100)
 - Instruction system: 16-bit instructions
 - Instruction set: Transfer, arithmetic operations, comparison, logic operations, multiplication/division, bit manipulations, bit logic operations, jump, conditional jump, call return stack manipulations, arithmetic shift, and so on
 - On-Chip debug function
 - Minimum instruction execution time
 - Approx 30.5 μ s (at 32.768kHz system clock)
 - Approx 0.125 μ s (at 8MHz system clock) @ $DV_{DD} = 2.2$ to 3.6V
 - Approx 0.250 μ s (at 4MHz system clock) @ $DV_{DD} = 2.0$ to 3.6V
- Internal memory
 - Has 160-Kbyte flash ROM(80K \times 16-bit) built in. (544 byte of test domain that it cannot be used is included)
 - Has 3-Kbyte flash ROM built in. (area in which self rewriting is possible.512Byte \times 6)
 - Has 2-Kbyte RAM (2048 \times 8 bits) built in.
 - Has 16-Mbit P2ROM built in. (only ML610Q360)
- Interrupt controller
 - 2 non-maskable interrupt sources (Internal source: 1, External source: 1)
 - 25 maskable interrupt sources (Internal source: 19, External source: 6)
- Time base counter
 - Low-speed time base counter \times 1 channel
 - High-speed time base counter \times 1 channel
- Watchdog timer
 - Generates a non-maskable interrupt upon the first overflow and a system reset occurs upon the second
 - Free running
 - Overflow period: 4 types selectable (125ms, 500ms, 2s, and 8s)
- Timers
 - 8 bits \times 8ch (16-bit configuration available)



- Voice output function
 - Voice synthesis method: 4-bit ADPCM2 / non-linear PCM / straight 8-bit PCM / straight 16-bit PCM
 - Sampling frequency: 8/16/32 kHz; 10.7/21.3 kHz; 6.4/12.8/25.6 kHz
- D/A converter
 - 12-bit D/A converter
- Speaker amplifier output power
 - 0.5W(at 3.0V)
 - Thermal detection circuit
 - Disconnection detection circuit
- Synchronous serial port
 - 2ch
 - Master/slave selectable
 - LSB first/MSB first selectable
 - 8-bit length/16-bit length selectable
- UART
 - Half-duplex × 2ch or half-duplex × 1ch + full-duplex × 1ch
 - TXD / RXD
 - Bit length, parity/no parity, odd parity/even parity, 1 stop bit/2 stop bits
 - Positive logic/negative logic selectable
 - Built-in baud rate generator
- Successive approximation type A/D converter
 - 12-bit A/D converter
 - Input: 4ch (ch0-2:External input
ch3: A regulator output (V_{DDR}) or a temperature sensor output (TEMPO))
 - Conversion time: 20 μ s per channel at 8MHz $AV_{DD} \geq 2.5V$
 - Conversion time: 28 μ s per channel at 8MHz $AV_{DD} \geq 2.2V$
- Temperature sensor
 - Measuring range : $-40^{\circ}C$ to $+85^{\circ}C$
- Regulator output (V_{DDR})
 - $1.5V \pm 50mV$ (at $-40^{\circ}C$ to $+85^{\circ}C$ and when a V_{DDR} pin is no-load)
 - 1.5V / 0V / HiZ selectable
- General-purpose ports
 - Non-maskable interrupt input port × 1ch
 - Input-only port × 7ch
 - Output-only port × 3ch (including secondary functions)
 - Input/output × 29ch (including secondary functions)
- Supply voltage supervisor circuit
 - Judgment accuracy: $\pm 1.5\%$ (Typ.)
 - Judgment Voltage: A binary to selection is possible
 - This function can be used as supply voltage supervisor reset.

- Reset
 - Reset through the RESET_N pin
 - Power-on reset generation when powered on
 - Reset by the watchdog timer (WDT) overflow
 - Reset when oscillation stop of the low-speed clock is detected
 - Voltage level supervisor reset
- Clock
 - Low-speed clock (This LSI can not guarantee the operation without low-speed clock)
Crystal oscillation (32.768 kHz)
 - High-speed clock
Built-in oscillation (8.192MHz), external clock
- Power management
 - HALT mode: Instruction execution by CPU is suspended (peripheral circuits are in operating states).
 - STOP mode: Stop of low-speed oscillation and high-speed oscillation (Operations of CPU and peripheral circuits are stopped.)
 - Clock gear: The frequency of high-speed system clock can be changed by software (1/1, 1/2, 1/4, or 1/8 of the oscillation clock)
 - Block control function: Operation of an intact functional block circuit is powered down. (register reset and clock stop)
- Shipment
 - 64-pin TQFP
ML610Q359-xxxTB (blank product: ML610Q359-NNNTB)
ML610Q360-xxxTB (blank product: ML610Q360-NNNTB)
xxx: ROM code number
- Guaranteed operating range
 - Operating temperature: -40°C to 85°C (for ML610Q359)
: -10°C to 65°C (P2ROM movement of ML610Q360)
 - Operating voltage: $DV_{DD} = 2.0\text{V}$ to 3.6V , $SPV_{DD} = 2.2\text{V}$ to 3.6V , $AV_{DD} = 2.2\text{V}$ to 3.6V

BLOCK DIAGRAM

Block Diagram of ML610Q359

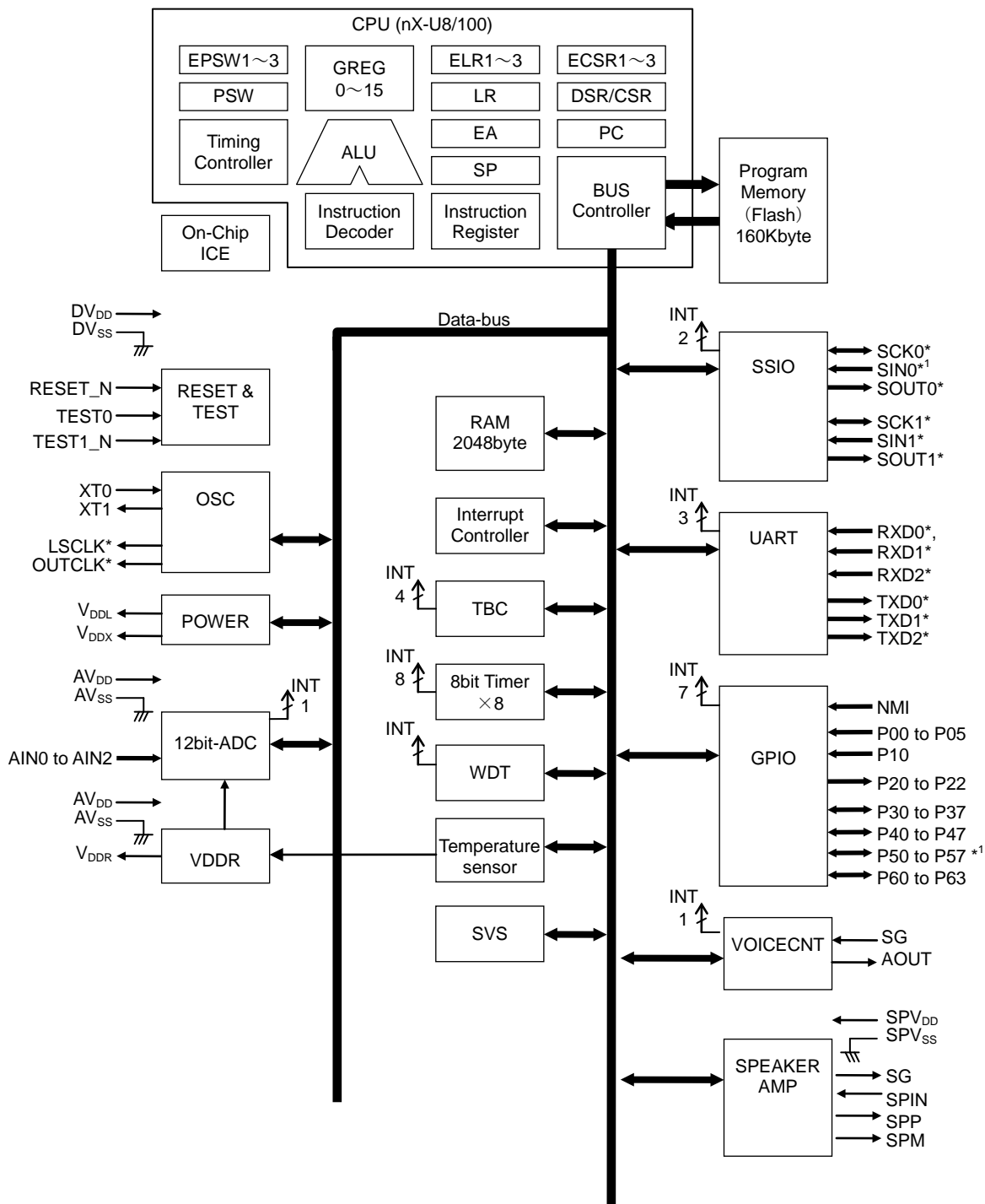

* : Secondary or tertiary or fourthly function

*¹: It is the point with the difference in ML610Q359 and ML610Q360

Figure 1 Block Diagram of ML610Q359

Block Diagram of ML610Q360

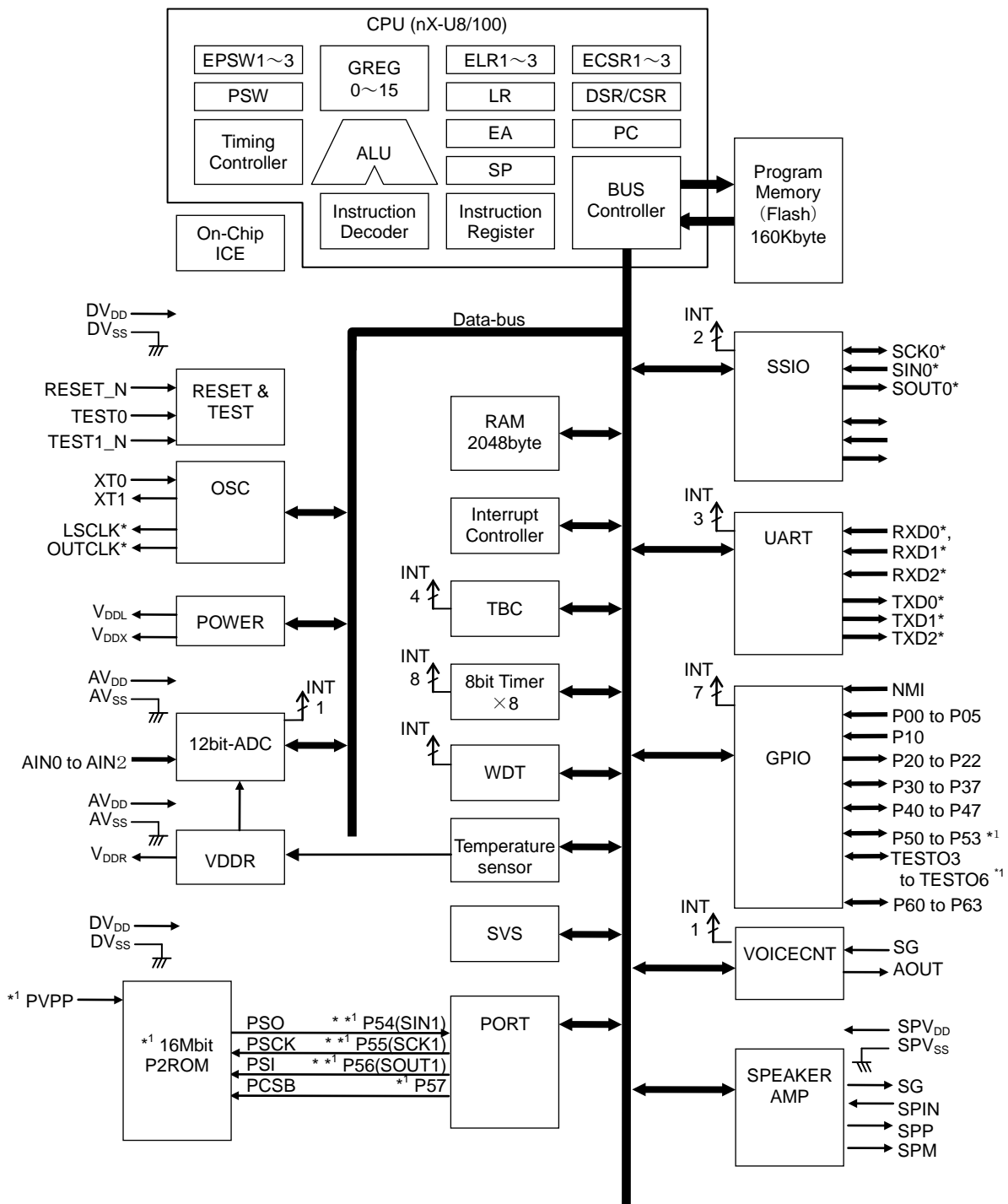

* : Secondary or tertiary or fourthly function

*¹: It is the point with the difference in ML610Q359 and ML610Q360

Figure 2 Block Diagram of ML610Q360

PIN CONFIGURATION

ML610Q359 TQFP package product

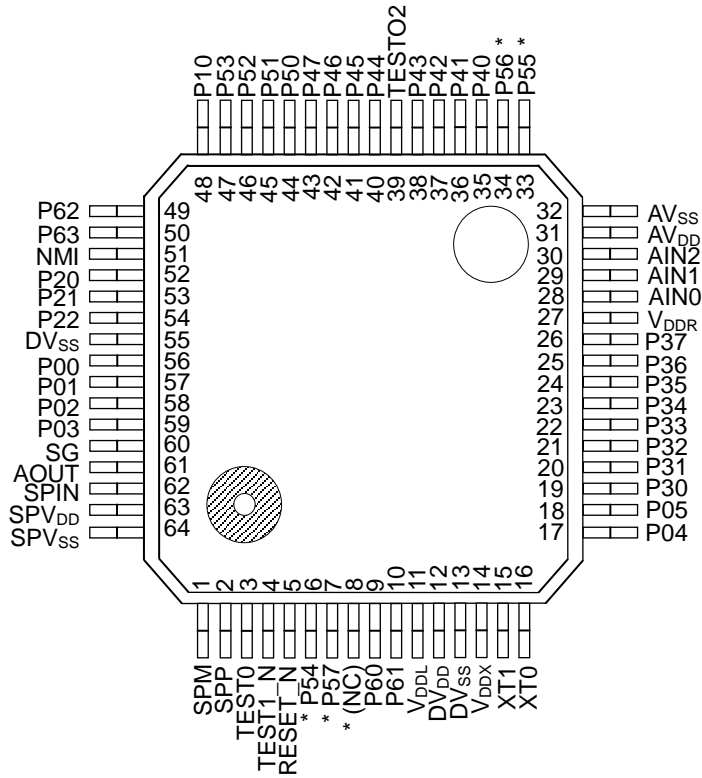

*: It is the point with the difference in ML610Q359 and ML610Q360
 (NC): No Connection

Figure 3 Pin Configuration of ML610Q359 Package Product

ML610Q360 TQFP package product

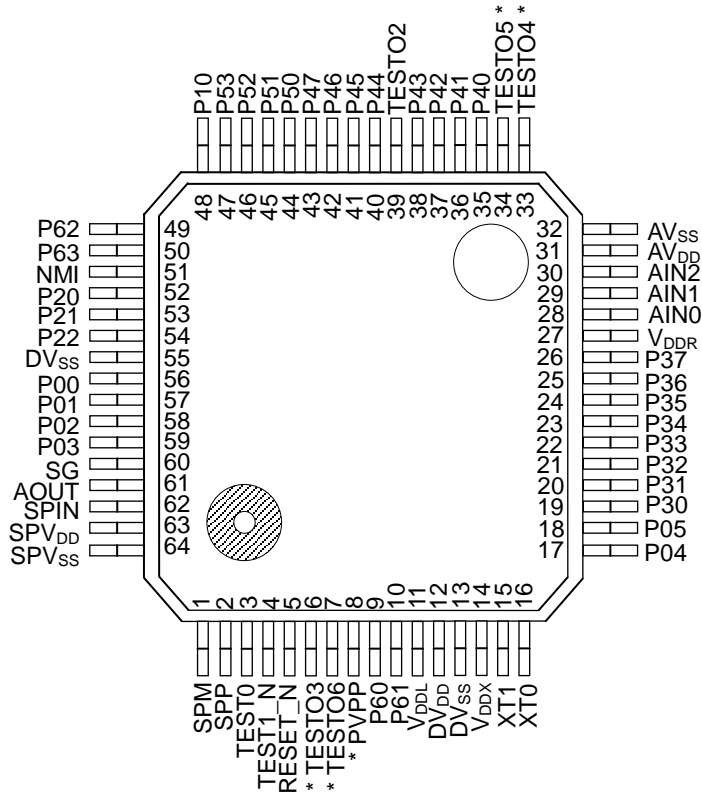

*: It is the point with the difference in ML610Q359 and ML610Q360

Figure 4 Pin Configuration of ML610Q360 Package Product

LIST OF PINS

Pin No		Primary function			Secondary function			Tertiary function		
Q359	Q360	Pin name	I/O	Description	Pin name	I/O	Description	Pin name	I/O	Description
13,55	13,55	DV _{SS}	—	Negative power supply pin	—	—	—	—	—	—
12	12	DV _{DD}	—	Positive power supply pin	—	—	—	—	—	—
11	11	V _{DDL}	—	Power supply for internal logic (internally generated)	—	—	—	—	—	—
14	14	V _{DDX}	—	Power supply pin for oscillation (internally generated)	—	—	—	—	—	—
27	27	V _{DDR}	—	Reference voltage output of 1.5V	—	—	—	—	—	—
64	64	SPV _{SS}	—	Negative power supply pin for built-in speaker amplifier	—	—	—	—	—	—
63	63	SPV _{DD}	—	Positive power supply pin for built-in speaker amplifier	—	—	—	—	—	—
32	32	AV _{SS}	—	Negative power supply pin for successive-approximation type ADC/OP-amp	—	—	—	—	—	—
31	31	AV _{DD}	—	Positive power supply pin for successive-approximation type ADC/OP-amp	—	—	—	—	—	—
—	8	PVPP	—	High voltage power supply pin of data to building P2ROM	—	—	—	—	—	—
3	3	TEST0	I/O	Input/output pin for testing	—	—	—	—	—	—
4	4	TEST1_N	I	Input pin for testing	—	—	—	—	—	—
39	39	TESTO2	—	Output pin for testing	—	—	—	—	—	—
5	5	RESET_N	I	Reset input pin	—	—	—	—	—	—
16	16	XT0	I	Low-speed clock oscillation pin	—	—	—	—	—	—
15	15	XT1	O	Low-speed clock oscillation pin	—	—	—	—	—	—
61	61	AOUT	O	LINE output	—	—	—	—	—	—
62	62	SPIN	I	Analog input to the built-in speaker amplifier	—	—	—	—	—	—
60	60	SG	O	Reference power supply pin of the built-in speaker amplifier	—	—	—	—	—	—
2	2	SPP	O	Positive output pin of the built-in speaker amplifier	—	—	—	—	—	—
1	1	SPM	O	Negative output pin of the built-in speaker amplifier	—	—	—	—	—	—
28	28	AIN0	I	Successive-approximation type ADC input	—	—	—	—	—	—
29	29	AIN1	I	Successive-approximation type ADC input	—	—	—	—	—	—
30	30	AIN2	I	Successive-approximation type ADC input	—	—	—	—	—	—

Pin No		Primary function			Secondary function			Tertiary function			Fourthly function		
Q359	Q360	Pin name	I/O	Description	Pin name	I/O	Description	Pin name	I/O	Description	Pin name	I/O	Description
51	51	NMI	I	Input port, non-maskable interrupt	—	—	—	—	—	—	—	—	—
56	56	P00/EXI0	I	Input port / External	—	—	—	—	—	—	—	—	—
57	57	P01/EXI1	I	Input port / External	—	—	—	—	—	—	—	—	—
58	58	P02/EXI2 / RXD0 / RXD2	I	Input port / External interrupt / UART0 data input / UART2 data input	—	—	—	—	—	—	—	—	—
59	59	P03/EXI3 / RXD1	I	Input port / External interrupt / UART1 data input	—	—	—	—	—	—	—	—	—
17	17	P04/EXI4/ T02P0CK	I	Input port / External interrupt / Timer0,2 external clock input	—	—	—	—	—	—	—	—	—
18	18	P05/EXI5/ T13P0CK	I	Input port / External interrupt / Timer1,3 external clock input	—	—	—	—	—	—	—	—	—
48	48	P10	I	Input port	OSC0	I	High-speed oscillation	—	—	—	—	—	—
52	52	P20/ LED0	O	Output port / LED drive	LSCLK	O	Low-speed clock output	—	—	—	—	—	—
53	53	P21/ LED1	O	Output port / LED drive	OUTCLK	O	high-speed clock output	—	—	—	—	—	—
54	54	P22/ LED2	O	Output port / LED drive	—	—	—	—	—	—	—	—	—
19	19	P30	I/O	Input/output port	—	—	—	—	—	—	—	—	—
20	20	P31	I/O	Input/output port	—	—	—	—	—	—	—	—	—
21	21	P32	I/O	Input/output port	—	—	—	—	—	—	—	—	—
22	22	P33	I/O	Input/output port	—	—	—	—	—	—	—	—	—
23	23	P34	I/O	Input/output port	—	—	—	—	—	—	—	—	—
24	24	P35	I/O	Input/output port	—	—	—	—	—	—	—	—	—
25	25	P36	I/O	Input/output port	—	—	—	—	—	—	—	—	—

Pin No		Primary function			Secondary function			Tertiary function			Fourthly function		
Q359	Q360	Pin name	I/O	Description	Pin name	I/O	Description	Pin name	I/O	Description	Pin name	I/O	Description
35	35	P40	I/O	Input/output port	—	—	—	SIN0	I	SSIO0 data input	—	—	—
36	36	P41	I/O	Input/output port	—	—	—	SCK0	I/O	SSIO0 synchronous clock input/output	—	—	—
37	37	P42	I/O	Input/output port	RXD0	I	UART0 data input	SOUT0	O	SSIO0 data output	RXD2	I	UART2 data input
38	38	P43	I/O	Input/output port	TXD0	O	UART0 data output	—	—	—	TXD2	O	UART2 data output
40	40	P44	I/O	Input/output port	—	—	—	SIN0	I	SSIO0 data input	—	—	—
41	41	P45	I/O	Input/output port	—	—	—	SCK0	I/O	SSIO0 synchronous clock input/output	—	—	—
42	42	P46	I/O	Input/output port	—	—	—	SOUT0	O	SSIO0 data output	—	—	—
43	43	P47	I/O	Input/output port	—	—	—	—	—	—	—	—	—
44	44	P50	I/O	Input/output port	—	—	—	SIN1	I	SSIO1 data input	—	—	—
45	45	P51	I/O	Input/output port	—	—	—	SCK1	I/O	SSIO1 synchronous clock input/output	—	—	—
46	46	P52	I/O	Input/output port	RXD1	I	UART1 data input	SOUT1	O	SSIO1 data output	—	—	—
47	47	P53	I/O	Input/output port	TXD1	O	UART1 data output	—	—	—	TXD2	O	UART2 data output
6	—	P54/ TEST O3	I/O	Input/output port	—	—	—	SIN1	I	SSIO1 data input	—	—	—
33	—	P55/ TEST O4	I/O	Input/output port	—	—	—	SCK1	I/O	SSIO1 synchronous clock input/output	—	—	—
34	—	P56/ TEST O5	I/O	Input/output port	—	—	—	SOUT1	O	SSIO1 data output	—	—	—
7	—	P57/ TEST O6	I/O	Input/output port	—	—	—	—	—	—	—	—	—
9	9	P60	I/O	Input/output port	—	—	—	—	—	—	—	—	—
10	10	P61	I/O	Input/output port	—	—	—	—	—	—	—	—	—
49	49	P62	I/O	Input/output port	—	—	—	—	—	—	—	—	—
50	50	P63	I/O	Input/output port	—	—	—	—	—	—	—	—	—

Note:

The function which has not been chosen is lost when it is chosen any of a secondary function, the Tertiary function, and the fourthly function they are. However, when using it as an input, it is possible to read input data with a port-n data register.

Complement: It is only ML610Q360. ML610Q359 does not correspond.

P54-P57 are connected with built-in P2ROM inside the chip, and each function exists. An external terminator name is set to TESTO3-TESTO6. Please make the external terminator open. The content of contact with P2ROM is shown below.

The terminator of built-in P2ROM	Explanation
PSO	serial data output It connects with P54/SIN1(tertiary functional use) inside.
PSCK	serial clock input It connects with P55/SCK1(tertiary functional use) inside.
PSI	serial data input It connects with P56/SOUT1(tertiary functional use) inside.
PCSB	chip select input It connects with P57(primary functional use) inside.

PIN DESCRIPTION

Pin name	I/O	Description	Primary/ Secondary	Logic
Power supply				
DV _{SS}	—	Negative power supply pin	—	—
DV _{DD}	—	Positive power supply pin	—	—
V _{DDL}	—	Positive power supply pin for internal logic (internally generated) Connect capacitors (C _L) (see Measuring Circuit 1) between this pin and DV _{SS} .	—	—
V _{DDX}	—	Power supply pin for oscillation (internally generated). Capacitors C _X (see measuring circuit 1) are connected between this pin and DV _{SS} .	—	—
V _{DDR}	—	Reference voltage output. Capacitors C _R (see measuring circuit 1) are connected between this pin and DV _{SS} .	—	—
SPV _{SS}	—	Negative power supply pin for built-in speaker amplifier	—	—
SPV _{DD}	—	Positive power supply pin for built-in speaker amplifier	—	—
AV _{SS}	—	Negative power supply pin for successive-approximation type ADC/op-amp	—	—
AV _{DD}	—	Positive power supply pin for successive-approximation type ADC/op-amp	—	—
PVPP		High voltage power supply pin of the data write to building P2ROM into. Besides, fix at the V _{SS} level.	—	—
Test				
TEST0	I/O	Input/output pin for testing. Has a pull-down resistor built in.	—	Positive
TEST1_N	I	Input pin for testing. Has a pull-up resistor built in.	—	Negative
TESTO2	—	Output pin for testing	—	—
System				
RESET_N	I	Reset input pin. When this pin is set to a “L” level, the device is placed in system reset mode and the internal circuit is initialized. If after that this pin is set to a “H” level, program execution starts. This pin has a pull-up resistor built in.	—	Negative
XT0	I		—	Positive
XT1	O		—	Negative
OSC0	I		Secondary	Positive
LSCLK	O	Low-speed clock output. This function is allocated to the secondary function of the P20 pin.	Secondary	—
OUTCLK	O	High-speed clock output. This function is allocated to the secondary function of the P21 pin.	Secondary	—
General-purpose input port				
P00 to P05	I	General-purpose input ports.	Primary	Positive
P10	I	General-purpose input/output ports. Provided with a secondary function for each port. Cannot be used as ports if their secondary functions are used.	Primary	Positive

Pin name	I/O	Description	Primary/ Secondary/ Tertiary/ Fourthly	Logic
General-output input port				
P20 to P22	O	General-purpose output ports. Provided with a secondary function for each port. Cannot be used as ports if their secondary functions are used.	Primary	Positive
General-purpose input/output port				
P30 to P37	I/O	General-purpose input/output ports. Provided with a secondary function for each port. Cannot be used as ports if their secondary functions are used.	Primary	Positive
P40 to P47				
P50 to P57				
P60 to P63				
UART				
TXD0	O	UART0 data output pin. Allocated to the secondary function of the P43 pin.	Secondary	Positive
RXD0	I	UART0 data input pin. Allocated to the primary function of the P02 pin and the secondary function of the P42 pin.	Secondary	Positive
TXD1	O	UART1 data output pin. Allocated to the secondary function of the P53 pin.	Secondary	Positive
RXD1	I	UART1 data input pin. Allocated to the primary function of the P03 pin and the secondary function of the P52 pin.	Secondary	Positive
TXD2	O	UART0 data output pin. Allocated to the fourthly function of the P43 pin and the fourthly function of the P53 pin.	Fourthly	Positive
RXD2	I	UART0 data input pin. Allocated to the primary function of the P02 pin and the fourthly function of the P42 pin.	Fourthly	Positive
Synchronous serial (SSIO)				
SIN0	I	Synchronous serial data input pin. Allocated to the tertiary function of the P40 pin and the tertiary function of the P44 pin.	Tertiary	Positive
SCK0	I/O	Synchronous serial clock input/output pin. Allocated to the tertiary function of the P41 pin and the tertiary function of the P45 pin.	Tertiary	—
SOUT0	O	Synchronous serial data output pin. Allocated to the tertiary function of the P42 pin and the tertiary function of the P46 pin.	Tertiary	Positive
SIN1	I	Synchronous serial data input pin. Allocated to the tertiary function of the P50 pin and the tertiary function of the P54 pin .	Tertiary	Positive
SCK1	I/O	Synchronous serial clock input/output pin. Allocated to the tertiary function of the P51 pin and the tertiary function of the P55 pin.	Tertiary	—
SOUT1	O	Synchronous serial data output pin. Allocated to the tertiary function of the P52 pin and the tertiary function of the P56 pin.	Tertiary	Positive
External interrupt				
NMI	I	External non-maskable interrupt input pin. The interrupt occurs on both the rising and falling edges.	Primary	Positive/ Negative
EXI0–EXI5	I	External maskable interrupt input pins. It is possible, for each bit, to specify whether the interrupt is enabled and select the interrupt edge by software. Allocated to the primary function of the P00–P05 pins.	Primary	Positive/ Negative

Pin name	I/O	Description	Primary/ Secondary/ Tertiary/ Fourthly	Logic
LED drive				
LED0–LED2	O	Pins for LED driving. Allocated to the primary function of the P20 to P22 pins.	Primary	Positive/ Negative
Voice output function				
AOUT	O	LINE output pin. The case of built-in speaker amplifier use, connect capacitors (C_{AOSP}) between this pin and the SPIN pin.	—	—
SPIN	I	Analog input pin of the internal speaker amplifier.	—	—
SG	O	Reference voltage output pin of the internal speaker amplifier.	—	—
SPP	O	Positive output pin of the internal speaker amplifier.	—	—
SPM	O	Negative output pin of the internal speaker amplifier.	—	—
Successive-approximation type A/D converter				
AIN0–AIN2	I	Analog inputs to Ch0–Ch2 of the successive-approximation type A/D converter.	—	—

TERMINATION OF UNUSED PINS**How to Terminate Unused Pins**

Pin	Recommended pin termination
RESET_N	Open
TEST0	Open
TEST1_N	Open
TESTO2	Open
AVDD	Connect to DVDD
AVSS	Connect to DVSS
AIN0 to AIN2	Open
SPVDD	Connect to DVDD
SPVSS	Connect to DVSS
PVPP	Open
AOUT	Open
SPIN	Open
SG	Open
SPP	Open
SPM	Open
P00 to P05	Connect to DVDD or DVSS
P10	Connect to DVDD or DVSS
P20 to P22	Open
P30 to P37	Open
P40 to P47	Open
P50 to P57	Open
TESTO3 to TESTO6	Open
P60 to P63	Open
VDDR	Open

Note:

For unused input ports or unused input/output ports, if the corresponding pins are configured as high-impedance inputs and left open, the supply current may become excessively large. Therefore, it is recommended to configure those pins as either inputs with a pull-down resistor/pull-up resistor or outputs.

ELECTRICAL CHARACTERISTICS

Absolute Maximum Ratings

(DV_{SS} = AV_{SS} = SPV_{SS} = 0V)

Parameter	Symbol	Condition	Rating	Unit
Power supply voltage 1	DV _{DD}	Ta=25°C	-0.3 to +7.0	V
Power supply voltage 2	AV _{DD}	Ta=25°C	-0.3 to +7.0	V
Power supply voltage 3	SPV _{DD}	Ta=25°C	-0.3 to +7.0	V
Power supply voltage 4	V _{DDL}	Ta=25°C	-0.3 to +3.6	V
Power supply voltage 5	V _{DDX}	Ta=25°C	-0.3 to +3.6	V
Power supply voltage 6	V _{DDR}	Ta=25°C	-0.3 to +3.6	V
Power supply voltage 7	TESTO2	Ta=25°C	-0.3 to +9.5	V
Input voltage	V _{IN}	Ta=25°C	-0.3 to DV _{DD} +0.3	V
Output voltage	V _{OUT}	Ta=25°C	-0.3 to DV _{DD} +0.3	V
Output current 1	I _{OUT1}	Port 3, 4, 5, 6 Ta=25°C	-12 to +11	mA
Output current 2	I _{OUT2}	Port 2, Ta=25°C	-12 to +60	mA
Power dissipation	PD	ML610Q359 Ta=25°C	472	mW
		ML610Q360	562	mW
Storage temperature	T _{STG}	—	-55 to +150	°C

Recommended Operating Conditions

(DV_{SS} = AV_{SS} = SPV_{SS} = 0V)

Parameter	Symbol	Condition	Range	Unit
Operating temperature	T _{OP}	—	-40 to +85	°C
Operating voltage	DV _{DD}	—	2.0 to 3.6	V
	SPV _{DD}	—	2.2 to 3.6	
	AV _{DD}	—	2.2 to 3.6	
	f _{OP}	DV _{DD} =2.2V to 3.6V	3.8k to 8.4M	
Operating frequency (CPU)	f _{OP}	DV _{DD} =2.0V to 3.6V	3.8k to 4.2M	Hz
		—	—	—
Low speed clock oscillation frequency	f _{XTL}	—	32.768k	Hz
Low speed clock oscillation Capacitor externally connected to Low speed clock oscillation pin	C _{DL}	MC-146 (EPSON TOYOCOM)	14	pF
	C _{GL}		14	
Capacitor externally connected to V _{DDL} pin	C _L	—	10±30%	μF
Capacitor externally connected to V _{DDX} pin	C _X	—	0.1±30%	μF
Capacitor externally connected to V _{DDR} pin	C _R	—	1±30%	μF
Capacitor externally connected to AOUT pin – SPIN pin	C _{AOSP}	—	0.022±30%	μF
Capacitor externally connected to SG pin	C _{SG}	—	0.1±30%	μF

Flash Memory Operating Conditions

(DV_{SS} = AV_{SS} = SPV_{SS} = 0V)

Parameter	Symbol	Condition	Range	Unit
Operating temperature	T _{OP}	At write/erase	-20 to +75	°C
Operating voltage	DV _{DD}	At write/erase	2.2 to 3.6	V
Maximum rewrite count	C _{EPD}	Data area(1024B)	6000	times
	C _{EPP}	Program area	100	
Data retention period	Y _{DR}	—	10	years

DC Characteristics (1 of 5)

(DV_{DD}= AV_{DD}=SPV_{DD}= 2.0 to 3.6V, DV_{SS}=AV_{SS}=SPV_{SS}=0V, Ta=-40 to +85°C, unless otherwise specified)

Parameter	Symbol	Condition	Min.	Typ.	Max.	Unit	Measuring circuit
High-speed oscillation start time	T _{XTH}	—	—	1	3	ms	1
Low-speed crystal oscillation start time	T _{XTL}	—	—	—	2	s	
High-speed oscillator frequency	f _{HPLL}	LSCLK=32.768kHz	typ -2.5%	8.192M	typ +2.5%	Hz	
Reset pulse width	P _{RST}	—	100	—	—	μs	
Reset noise rejection pulse width	P _{NRST}	—	—	—	0.3		
Time from power-on reset to power-up	T _{POR}	—	—	—	10	ms	

Reset

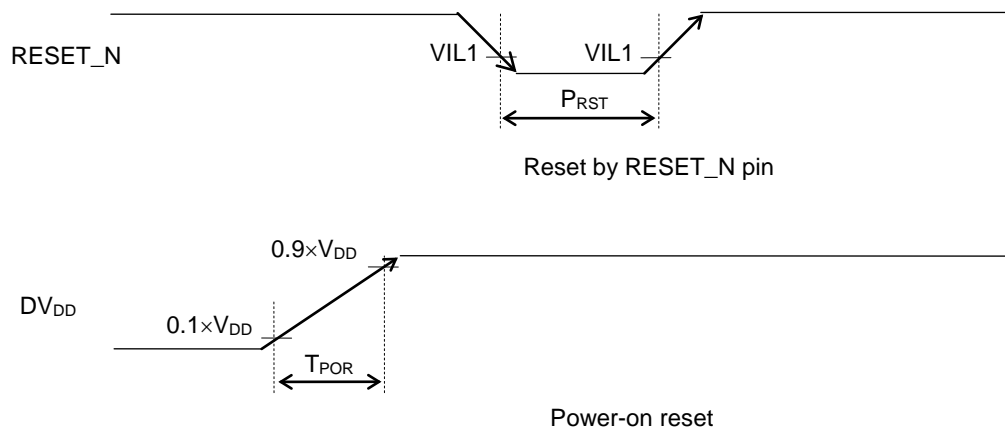

DC Characteristics (2 of 5)

($DV_{DD}=AV_{DD}=SPV_{DD}= 2.3$ to $3.6V$, $DV_{SS}=AV_{SS}=SPV_{SS}=0V$, $T_a=-40$ to $+85^{\circ}C$, unless otherwise specified)

Parameter	Symbol	Condition	Min.	Typ.	Max.	Unit	Measuring circuit
LINE amplifier output voltage range	V_{AD}	At $10k\Omega$ load for DV_{SS}	$SPV_{DD} \times 1/6$	—	$SPV_{DD} \times 5/6$	V	1
SG output voltage	V_{SG}	—	$0.95 \times SPV_{DD}/2$	$SPV_{DD}/2$	$1.05 \times SPV_{DD}/2$	V	
SG output resistance	R_{SG}	—	57	96	135	k Ω	
SPM, SPP output load resistance	R_{LSP}	—	8	—	—	Ω	
Speaker amplifier output power	P_{SPO1}	$SPV_{DD} = 3.0V$, $f = 1kHz$, $RSPO = 8\Omega$, $THD \geq 17\%$ At SPIN Input	—	0.5	—	W	
Output offset voltage between SPM and SPP with no signal present	V_{OF}	$SPV_{DD}=3.0V$, SPIN – SPM, Gain = +6dB With a load of 8Ω	-30	—	+30	mV	

DC Characteristics (3 of 5)(DV_{DD}=AV_{DD}=SPV_{DD}=2.0 to 3.6V, DV_{SS}=AV_{SS}=SPV_{SS}=0V, Ta=-40 to +85°C, unless otherwise specified)

Parameter	Symbol	Condition	Min.	Typ.	Max.	Unit	Measuring circuit	
Supply current 1	IDD1	CPU: In STOP state. Low-speed/high-speed oscillation: stopped	Ta ≤ +50°C	—	0.5	2.5	μA	1
			Ta ≤ +85°C	—	0.5	8		
Supply current 2	IDD2	CPU: In HALT state (LTBC, WDT: Operating ^{*2}) High-speed oscillation: Stopped	Ta ≤ +50°C	—	1.7	3.5		
			Ta ≤ +85°C	—	1.7	10		
Supply current 3	IDD3	CPU: Running at 32.768 kHz ^{*1} High-speed oscillation: Stopped	—	16	25			
Supply current 4	IDD4	CPU: Running at 8.192MHz High-speed oscillation: Stopped	DV _{DD} = SPV _{DD} = 3.0V	—	4.5	10	mA	

*1: Case when the CPU operating rate is 100% (with no HALT state)

*2: Significant bits of BLKCON0 to BLKCON4 registers are all "1".

Supply-voltage supervisor circuit(DV_{DD}=AV_{DD}=SPV_{DD}=2.0 to 3.6V, DV_{SS}=AV_{SS}=SPV_{SS}=0V, Ta=-40 to +85°C, unless otherwise specified)

Parameter	Symbol	Condition	Min.	Typ.	Max.	Unit	Measuring circuit	
VLS judging voltage	V _{SVS1}	Ta = 25°C	DV _{DD} falling	Typ.	2.05	Typ.	V	1
			DV _{DD} rising	-1.5%	2.13	+1.5%		
	V _{SVS2}	Ta = 25°C	DV _{DD} falling	Typ.	2.25	Typ.		
			DV _{DD} rising	-1.5%	2.33	+1.5%		
VLS self-consumption current	I _{SVS}	—	—	10	—	μA		

Temperature sensor(DV_{DD}=AV_{DD}=SPV_{DD}=2.0 to 3.6V, DV_{SS}=AV_{SS}=SPV_{SS}=0V, Ta=-40 to +85°C, unless otherwise specified)

Parameter	Symbol	Condition	Min.	Typ.	Max.	Unit	Measuring circuit
TEMPO output voltage	V _{TEMPO}	Ta = 25°C	0.95	1.3	1.6	V	1
TEMPO temperature inclination	Δ _{TEMPO}	Ta=-40°C to +25°C	—	-3.9	—	mV/°C	
		Ta=+25°C to +85°C	—	-4.1	—		

Regulator output(DV_{DD}=AV_{DD}=SPV_{DD}=2.0 to 3.6V, DV_{SS}=AV_{SS}=SPV_{SS}=0V, Ta=-40 to +85°C, unless otherwise specified)

Parameter	Symbol	Condition	Min.	Typ.	Max.	Unit	Measuring circuit
V _{DDR} output voltage	V _{DDR}	No load	1.45	1.5	1.55	V	1

DC Characteristics (4 of 5)(DV_{DD}=AV_{DD}=SPV_{DD}=2.0 to 3.6V, DV_{SS}=AV_{SS}=SPV_{SS}=0V, Ta=-40 to +85°C, unless otherwise specified)

Parameter	Symbol	Condition	Min.	Typ.	Max.	Unit	Measuring circuit
-----------	--------	-----------	------	------	------	------	-------------------

Output voltage 1 (P20 to P22) (P30 to P37) (P40 to P47) (P50 to P57) (P60 to P63)	VOH1	IOH1 = -0.5mA		DV _{DD} -0.5	—	—	V	2
	VOL1	IOL1 = +0.5mA		—	—	0.5		
Output voltage 2 (P20 to P22)	VOL2	When LED drive mode is selected	IOL2=+20mA DV _{DD} ≥2.5V	—	—	0.5		
出力リーク (P20 to P22) (P30 to P37) (P40 to P47) (P50 to P57) (P60 to P63)	IOOH	VOH = DV _{DD} (in high-impedance state)		—	—	1	μA	3
	IOOL	VOL = DV _{SS} (in high-impedance state)		-1	—	—		
Input current 1 (RESET_N) (TEST1_N)	I IH1	VIH1 = DV _{DD}		0	—	-1	μA	4
	I IL1	VIL1 = DV _{SS}		-1500	-300	-20		
Input current 2 (NMI) (P00 to P05) (P10) (P30 to P37) (P40 to P47) (P50 to P57) (P60 to P63)	I IH2	VIH2 = DV _{DD} (when pulled down)		2	30	250		
	I IL2	VIL2 = DV _{SS} (when pulled up)		-250	-30	-2		
	I IH2Z	VIH2 = DV _{DD} (in high-impedance state)		—	—	1		
	I IL2Z	VIL2 = DV _{SS} (in high-impedance state)		-1	—	—		
Input current 3 (TEST0)	I IH3	VIH3=DV _{DD}		20	300	1500		
	I IL3	VIL3=DV _{SS}		-1	—	—		

DC Characteristics (5 of 5)

($DV_{DD}=AV_{DD}=SPV_{DD}=2.0$ to $3.6V$, $DV_{SS}=AV_{SS}=SPV_{SS}=0V$, $T_a=-40$ to $+85^{\circ}C$, unless otherwise specified)

Parameter	Symbol	Condition	Min.	Typ.	Max.	Unit	Measuring circuit
Input voltage 1 (RESET_N) (TEST0) (TEST1_N) (NMI) (P00 to P05) (P10) (P30 to P37) (P40 to P47) (P50 to P57) (P60 to P63)	VIH1	—	$0.7 \times DV_{DD}$	—	DV_{DD}	V	5
	VIL1	—	0	—	$0.3 \times DV_{DD}$		
Hysteresis width (RESET_N) (TEST0) (TEST1_N) (NMI) (P00 to P05) (P10) (P30 to P37) (P40 to P47) (P50 to P57) (P60 to P63)	ΔV_T	—	$0.05 \times DV_{DD}$	—	$0.4 \times DV_{DD}$		
Input pin capacitance (NMI) (P00 to P05) (P10) (P30 to P37) (P40 to P47) (P50 to P57) (P60 to P63)	CIN	$f = 10kHz$ $V_{rms} = 50mV$ $T_a = 25^{\circ}C$	—	—	10	pF	—

Hysteresis Width

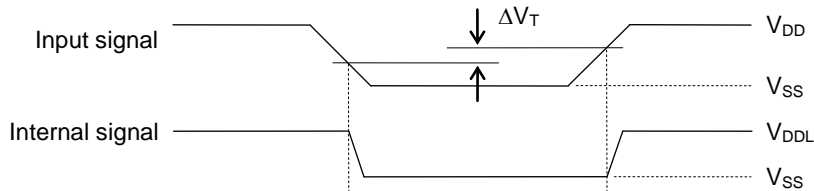

Measuring Circuits

Measuring circuit 1

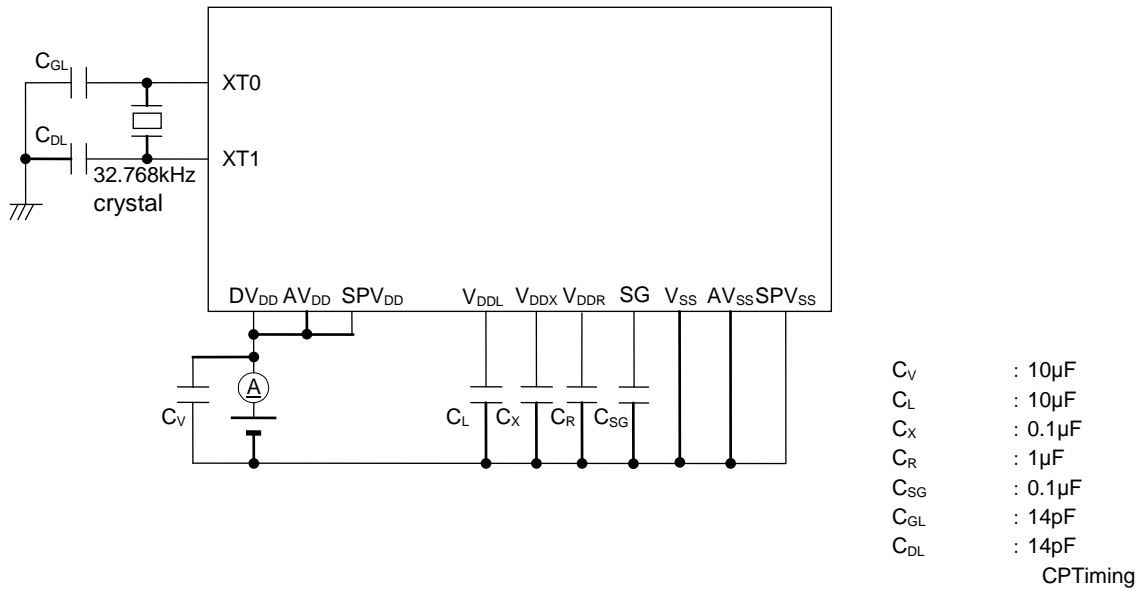

Measuring circuit 2

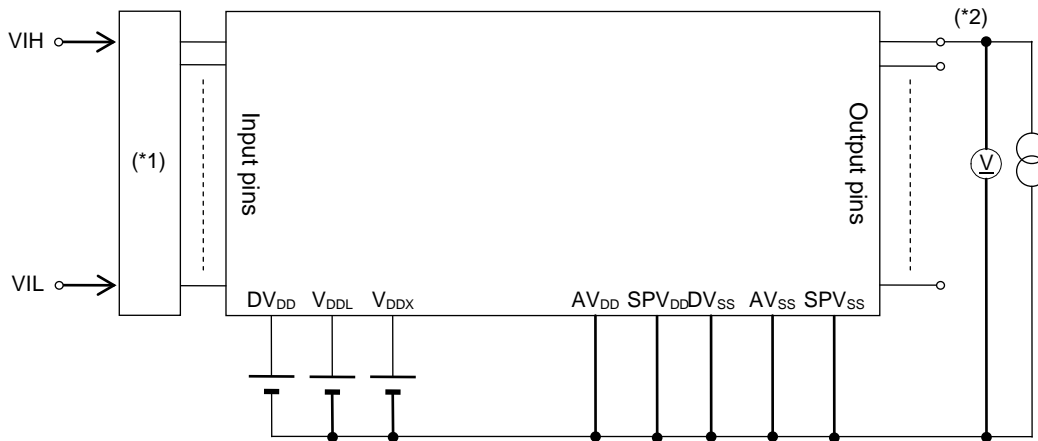

*1: Input logic circuit to determine the specified measuring conditions.

*2: Measured at the specified output pins.

Measuring circuit 3

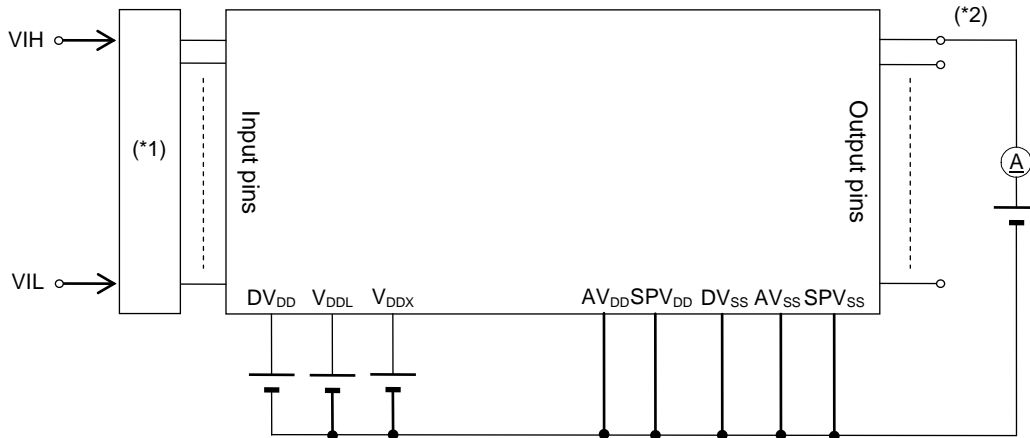

*1: Input logic circuit to determine the specified measuring conditions.
 *2: Measured at the specified output pins.

Measuring circuit 4

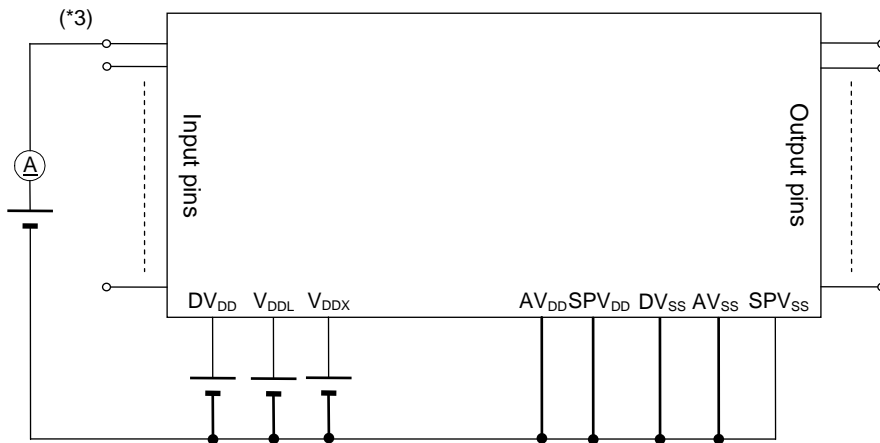

*3: Measured at the specified input pins.

Measuring circuit 5

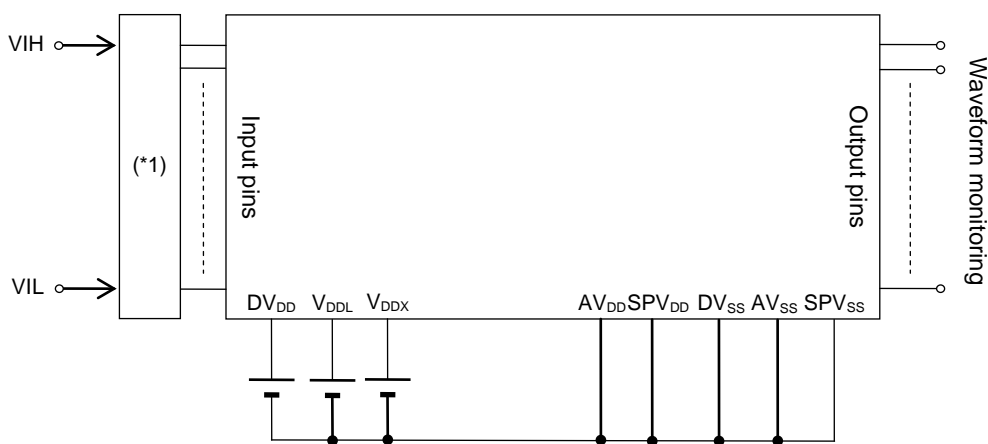

*1: Input logic circuit to determine the specified measuring conditions.

AC Characteristics (External Interrupt)

($DV_{DD}=AV_{DD}=SPV_{DD}=2.0$ to $3.6V$, $DV_{SS}=AV_{SS}=SPV_{SS}=0V$, $T_a=-40$ to $+85^{\circ}C$, unless otherwise specified)

Parameter	Symbol	Condition	Min.	Typ.	Max.	Unit
External interrupt disable period	T_{NUL}	Interrupt: Enabled (MIE = 1), CPU: NOP operation	$2.5 \times$ sysclk	—	$3.5 \times$ sysclk	μs

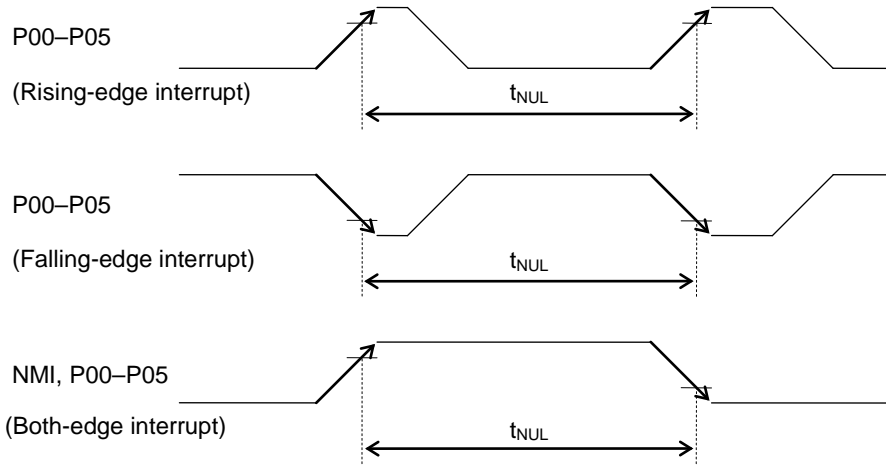

AC Characteristics (Synchronous Serial Port)

($DV_{DD}=AV_{DD}=SPV_{DD}=2.0$ to $3.6V$, $DV_{SS}=AV_{SS}=SPV_{SS}=0V$, $T_a=-40$ to $+85^{\circ}C$, unless otherwise specified)

Parameter	Symbol	Condition	Min.	Typ.	Max.	Unit
SCK input cycle (slave mode)	t_{SCYC}	High-speed oscillation stopped	10	—	—	μs
		During high-speed oscillation	500	—	—	ns
SCK output cycle (master mode)	t_{SCYC}	—	—	$SCK^{(*)}$	—	s
SCK input pulse width (slave mode)	t_{SW}	High-speed oscillation stopped	4	—	—	μs
		During high-speed oscillation	200	—	—	ns
SCK output pulse width (master mode)	t_{SW}	—	$SCK^{(*)}$ $\times 0.4$	$SCK^{(*)}$ $\times 0.5$	$SCK^{(*)}$ $\times 0.6$	s
SOUT output delay time (slave mode)	t_{SD}	—	—	—	180	ns
SOUT output delay time (master mode)	t_{SD}	—	—	—	80	ns
SIN input setup time (slave mode)	t_{SS}	—	50	—	—	ns
SIN input hold time	t_{SH}	—	50	—	—	ns

*1: Clock period selected by SOCK3-0 of the serial port 0 mode register (SIO0MOD1)

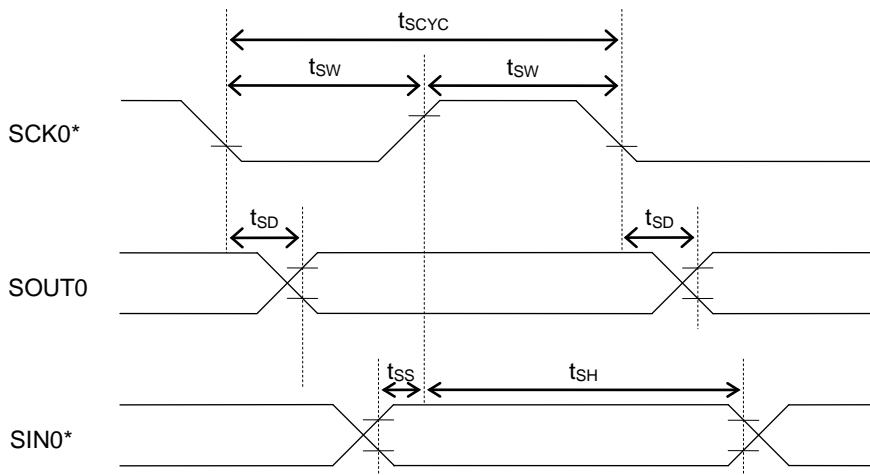

*: Indicates the tertiary function of the corresponding port.

Electrical Characteristics of Successive Approximation Type A/D Converter

($DV_{DD}=SPV_{DD}=2.0$ to $3.6V$, $AV_{DD}=2.2$ to $3.6V$, $DV_{SS}=AV_{SS}=SPV_{SS}=0V$, $T_a=-40$ to $+85^\circ C$, unless otherwise specified)

Parameter	Symbol	Condition	Min.	Typ.	Max.	Unit
Resolution	n	—	—	—	12	bit
Integral non-linearity error	IDL	$2.7V \leq V_{REF} \leq 3.6V$	-4	—	+4	LSB
		$2.2V \leq V_{REF} \leq 2.7V$	-6	—	+6	
Differential non-linearity error	DNL	$2.7V \leq V_{REF} \leq 3.6V$	-3	—	+3	
		$2.2V \leq V_{REF} \leq 2.7V$	-5	—	+5	
Zero-scale error	V_{OFF}	—	-6	—	+6	
Full-scale error	FSE	—	-6	—	+6	
Input impedance	Z_I	—	—	—	5k	Ω
Conversion time	t_{CONV}	SACK=0 (HSCLK=3M to 4.2MHz) $2.2 \leq AV_{DD}$	—	224	—	ϕ/CH
		SACK=1 (HSCLK=3M to 8.4MHz) $2.5 \leq AV_{DD}$	—	160	—	

ϕ : Period of high-speed clock (HSCLK)

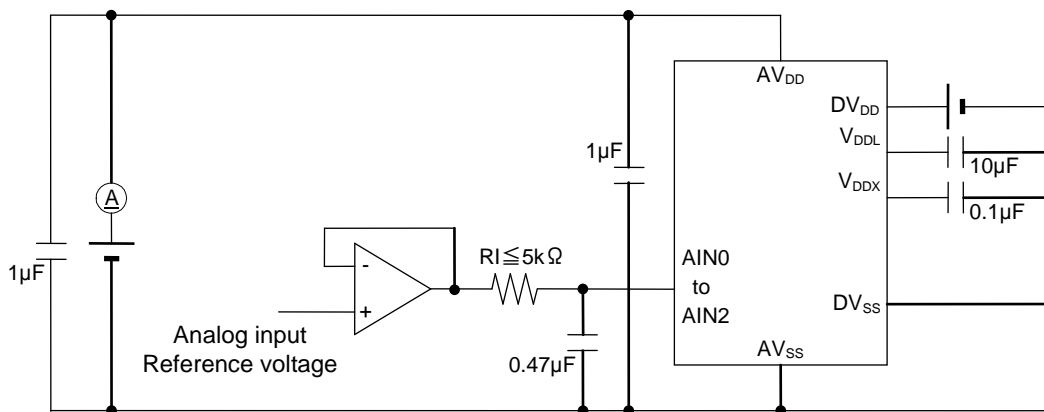

Power-on/Shutdown Sequence

- When the power rise time is 10 ms or less



- When the power rise time is more than 10 ms

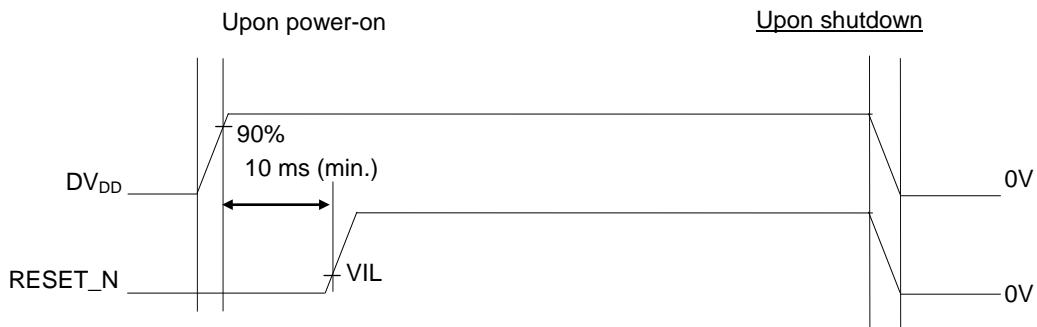

When DV_{DD} becomes less than 2.0V, please set DV_{DD} to 0V, and repeat a Power-on Sequence.
Please supply voltage to AV_{DD} simultaneous with DV_{DD} or After DV_{DD} rises.

PACKAGE DIMENSIONS

(Unit: mm)

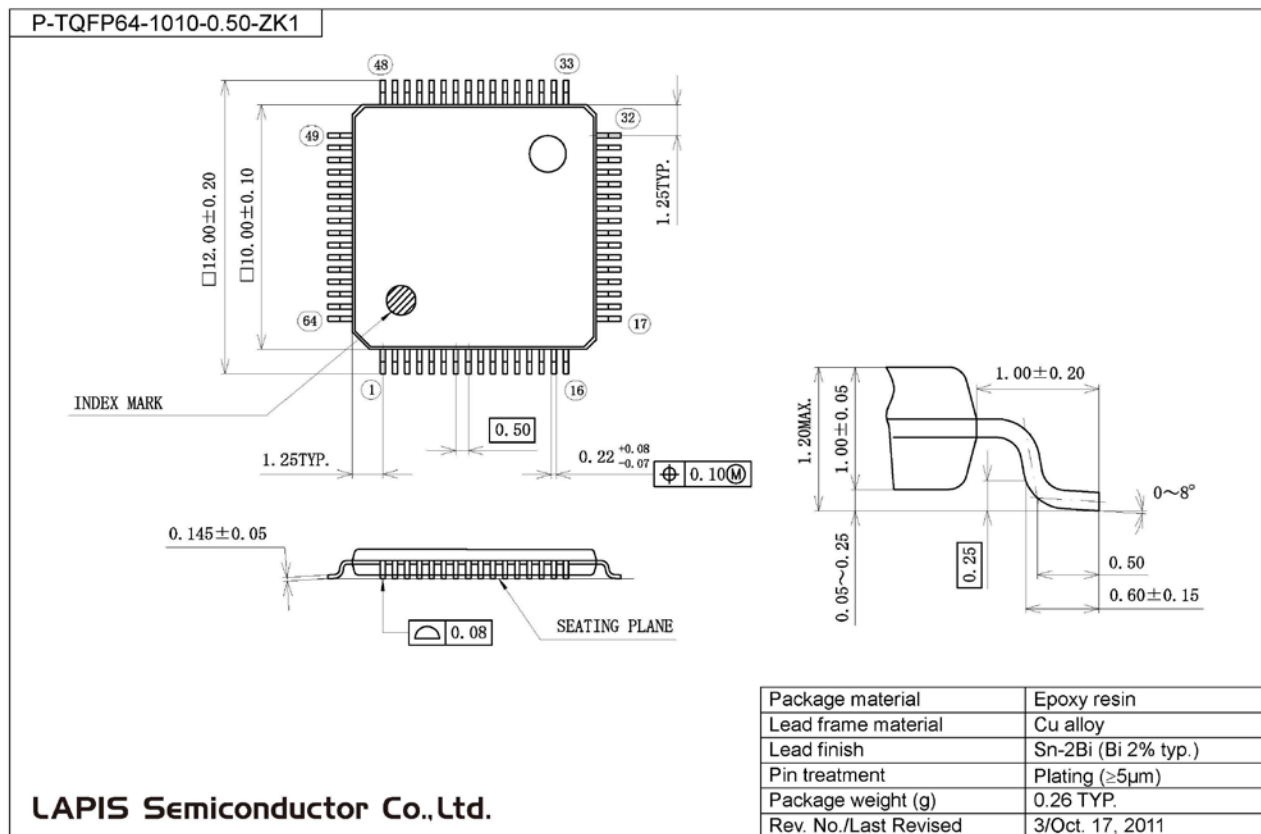

Notes for Mounting the Surface Mount Type Package

The surface mount type packages are very susceptible to heat in reflow mounting and humidity absorbed in storage. Therefore, before you perform reflow mounting, contact ROHM's responsible sales person for the product name, package name, pin number, package code and desired mounting conditions (reflow method, temperature and times).

The heat resistance (example) of this LSI is shown below. Heat resistance (θJa) changes with the size and the number of layers of a substrate.

Condition	Example 1 (EIA/JESD51)	Example 2
PCB	W/L/t= 76.2 / 114.5 / 1.6 (mm)	W/L/t= 50 / 50 / 1.6 (mm)
PCB Layer	2Layers	2Layers
Cu thickness	40(um)	30(um)
Cu density	60% / 60% (Two-Sided)	80% / 60% (Two-Sided)
Air cooling conditions	Calm (0m/sec)	Calm (0m/sec)
Heat resistance (θJa)	41.3[°C/W]	46.1[°C/W]
Power consumption of Chip PMax at Output Power 0.5W (3.6V)	0.472[W] (ML610Q359) 0.562[W] (ML610Q360)	

TjMax of this LSI is 125°C. TjMax is expressed with the following formulas.

$$TjMax = TaMax + \theta Ja \times PMax$$

REVISION HISTORY

Document No.	Date	Page		Description
		Previous Edition	Current Edition	
FEDL610Q359-01	Jul 31, 2015	–	–	Final edition 1

Notes

- 1) The information contained herein is subject to change without notice.
- 2) Although LAPIS Semiconductor is continuously working to improve product reliability and quality, semiconductors can break down and malfunction due to various factors. Therefore, in order to prevent personal injury or fire arising from failure, please take safety measures such as complying with the derating characteristics, implementing redundant and fire prevention designs, and utilizing backups and fail-safe procedures. LAPIS Semiconductor shall have no responsibility for any damages arising out of the use of our Products beyond the rating specified by LAPIS Semiconductor.
- 3) Examples of application circuits, circuit constants and any other information contained herein are provided only to illustrate the standard usage and operations of the Products. The peripheral conditions must be taken into account when designing circuits for mass production.
- 4) The technical information specified herein is intended only to show the typical functions of the Products and examples of application circuits for the Products. No license, expressly or implied, is granted hereby under any intellectual property rights or other rights of LAPIS Semiconductor or any third party with respect to the information contained in this document; therefore LAPIS Semiconductor shall have no responsibility whatsoever for any dispute, concerning such rights owned by third parties, arising out of the use of such technical information.
- 5) The Products are intended for use in general electronic equipment (i.e. AV/OA devices, communication, consumer systems, gaming/entertainment sets) as well as the applications indicated in this document.
- 6) The Products specified in this document are not designed to be radiation tolerant.
- 7) For use of our Products in applications requiring a high degree of reliability (as exemplified below), please contact and consult with a LAPIS Semiconductor representative: transportation equipment (i.e. cars, ships, trains), primary communication equipment, traffic lights, fire/crime prevention, safety equipment, medical systems, servers, solar cells, and power transmission systems.
- 8) Do not use our Products in applications requiring extremely high reliability, such as aerospace equipment, nuclear power control systems, and submarine repeaters.
- 9) LAPIS Semiconductor shall have no responsibility for any damages or injury arising from non-compliance with the recommended usage conditions and specifications contained herein.
- 10) LAPIS Semiconductor has used reasonable care to ensure the accuracy of the information contained in this document. However, LAPIS Semiconductor does not warrant that such information is error-free and LAPIS Semiconductor shall have no responsibility for any damages arising from any inaccuracy or misprint of such information.
- 11) Please use the Products in accordance with any applicable environmental laws and regulations, such as the RoHS Directive. For more details, including RoHS compatibility, please contact a ROHM sales office. LAPIS Semiconductor shall have no responsibility for any damages or losses resulting non-compliance with any applicable laws or regulations.
- 12) When providing our Products and technologies contained in this document to other countries, you must abide by the procedures and provisions stipulated in all applicable export laws and regulations, including without limitation the US Export Administration Regulations and the Foreign Exchange and Foreign Trade Act.
- 13) This document, in part or in whole, may not be reprinted or reproduced without prior consent of LAPIS Semiconductor.

Copyright 2015 LAPIS Semiconductor Co., Ltd.

LAPIS Semiconductor Co.,Ltd.

2-4-8 Shinyokohama, Kouhoku-ku,
Yokohama 222-8575, Japan
<http://www.lapis-semi.com/en/>

—