

- Notes:
1. Dimension shall be interpreted per ASME Y14.5M1994.
 2. Dimension marked ∇ & \blacktriangledown should be checked by Q.C. and process, engineers and \blacktriangledown should also check the CPK data.
- Specification
1. Current Rating: 1.0 AMP
 2. Voltage Rating: 30V AC,DC
 3. Dielectric Strength: 500V AC RMS for 1 minute.
 4. Contact Resistance: 30 m Ω Max.
 5. Insulator Resistance: 500M Ω Min. AT 250V DC.
 6. Mating/Unmating cycles: 2000cycles
 7. Temperature: -30°C to +60°C

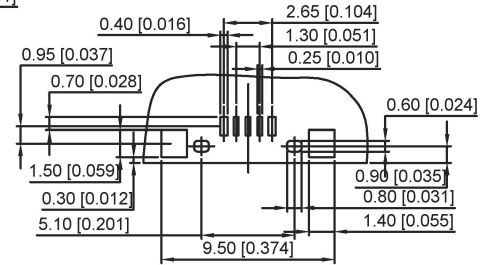

P.C.B LAYOUT

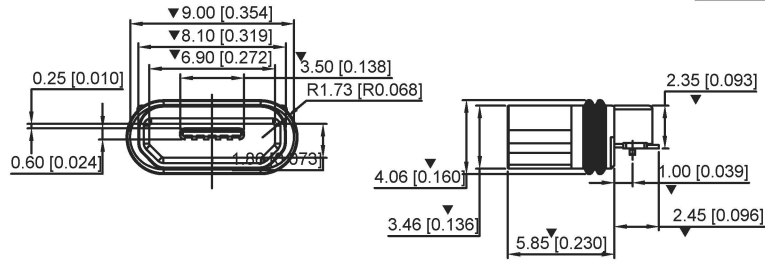
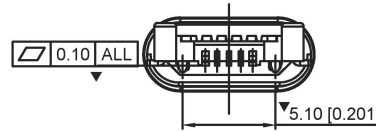
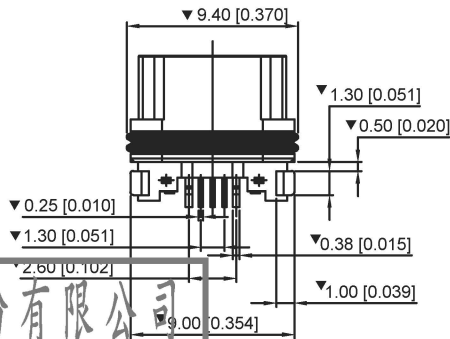

ITEM	PAPT NAME	QTY	MATERIAL	FINISHING
③	Shell	1	C2680R-H	Au/Ni Plating T=0.3mm
②	Terminal	5	Phosphor Bronze C5210R-EH	Au/Ni Plating T=0.2mm
①	Housing	1	HI-TEMP PLASIC UL 94V-0	BLACK

广东星坤科技股份有限公司

生效日期

MARK	DESCRIPTION	DATE	REVISED	APPROVED	REVISIONS

文件工程章

www.helloxkb.com www.helloxkb.com www.helloxkb.com

UNSPECIFIED TOLERANCES

DSND	DATE	SCALE: N/A	MODEL TYPE:
DWN	DATE	VIEW:	MICRO USB
CHKD	DATE	UNIT: mm/in	PART NO.:
APPD	DATE	SIZE: A4	DWG NO.:
XKB INDUSTRIAL PRECISION CO., LIMITED			U-E-M1SS-Y-1
WEIGHT	SHEET	REVISION	
1.0g	1/1	A0	