

3.5GHz WiMAX Driver / Power Amplifier



Key Features

- 3.3-3.8 GHz Bandwidth
- 41 dBc IMR3 @ 21 dBm Pout/tone
- 24 dB Nominal Gain
- 30 dBm Nominal P1dB
- 2.5% EVM at 22 dBm output power
- 13 dB step attenuator function
- Power sample port
- -1.5V Vg voltage to shut down drain current
- Self bias: +6 V 770mA
- Package Dimensions:
5.0 x 5.0 x 0.9 mm QFN

Primary Applications

- Fixed Broadband Wireless
- WiMAX

General Description

TGA2703-SM is a linear amplifier operating for 802.16 broadband wireless applications in 3.3 to 3.8 GHz frequency band. The PA delivers 24 dB of small-signal gain, 30dBm P1dB and 40 dBc IMR3 at 21 dBm output power per tone from a single +6V power supply. It has 2.5% EVM at 22 dBm output power. The TGA2703 incorporates a 13 dB step attenuator function and a power sampling port. The 50 ohm device requires minimum external components for operation, and is packaged in a low-cost, surface mount 5x5 QFN style package.

Lead-Free & RoHS compliant.
Demo boards are available.

Preliminary Measured Data

Bias Conditions: Vd = +6 V Self Bias

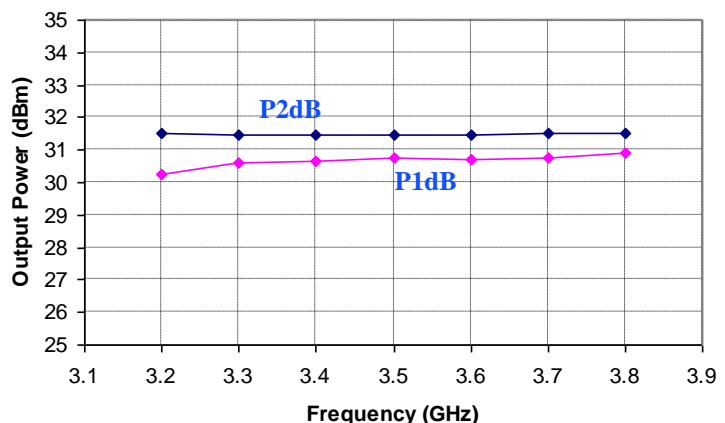
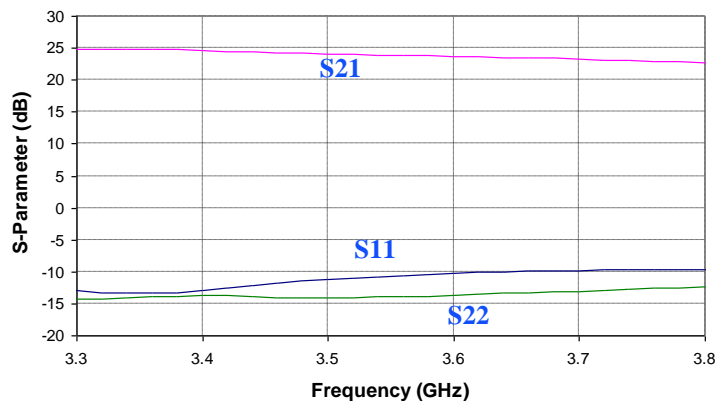

**TABLE I
 MAXIMUM RATINGS 1/**

SYMBOL	PARAMETER	VALUE	NOTES
V _d	Drain Voltage	7 V	<u>2/</u>
V _{ctrl}	Gain Control Voltage	7 V	
I _d	Drain Current	1.1 A	<u>2/ 3/</u>
I _g	Gate Current	6 mA	<u>3/</u>
P _{IN}	Input Continuous Wave Power	25 dBm	
P _D	Power Dissipation	7.7 W	<u>2/ 4/</u>
T _{CH}	Operating Channel Temperature	200 °C	<u>5/</u>
	Mounting Temperature (30 Seconds)	260 °C	
T _{STG}	Storage Temperature	-65 to 150 °C	

- 1/ These ratings represent the maximum operable values for this device.
- 2/ Combinations of supply voltage, supply current, input power, and output power shall not exceed P_D.
- 3/ Total current for the device.
- 4/ When operated at this bias condition with a base plate temperature of 85 °C, the median life is 6.2E4.
- 5/ Junction operating temperature will directly affect the device median time to failure (T_m). For maximum life, it is recommended that junction temperatures be maintained at the lowest possible levels.

TABLE II
ELECTRICAL CHARACTERISTICS
 (Ta = 25 °C Nominal)

			Notes
Response	Units	Typical	
Frequency Band	GHz		3.3-3.8GHz
Drain Operating Voltage	V	6	
Small Signal Gain	dB	24	
Input Return Loss	dB	10	
Output Return Loss	dB	12	
Control Gain Step	dB	13	
Psat	dBm	31.5	Pin at 11 dBm
P1dB	dBm	30	
EVM	%	TBD	at 3.5 GHz, 23 dBm Pout
Gain variation over temperature	dB/°C	0.03	
IMD3	dBc	41	at 21 dBm Pout/tone
TOI	dBm	42	at 21 dBm Pout/tone

**TABLE III
THERMAL INFORMATION**

Parameter	Test Conditions	T _{CH} (°C)	θ _{JC} (°C/W)	T _m (HRS)
θ _{JC} Thermal Resistance (channel to backside of package)	V _d = 6V I _D = 0.77 A P _{diss} = 4.62 W	145.5	13.1	3.8E+6

Note: Package backside soldered to carrier at 85 °C baseplate temperature.

Median Lifetime (T_m) vs. Channel Temperature

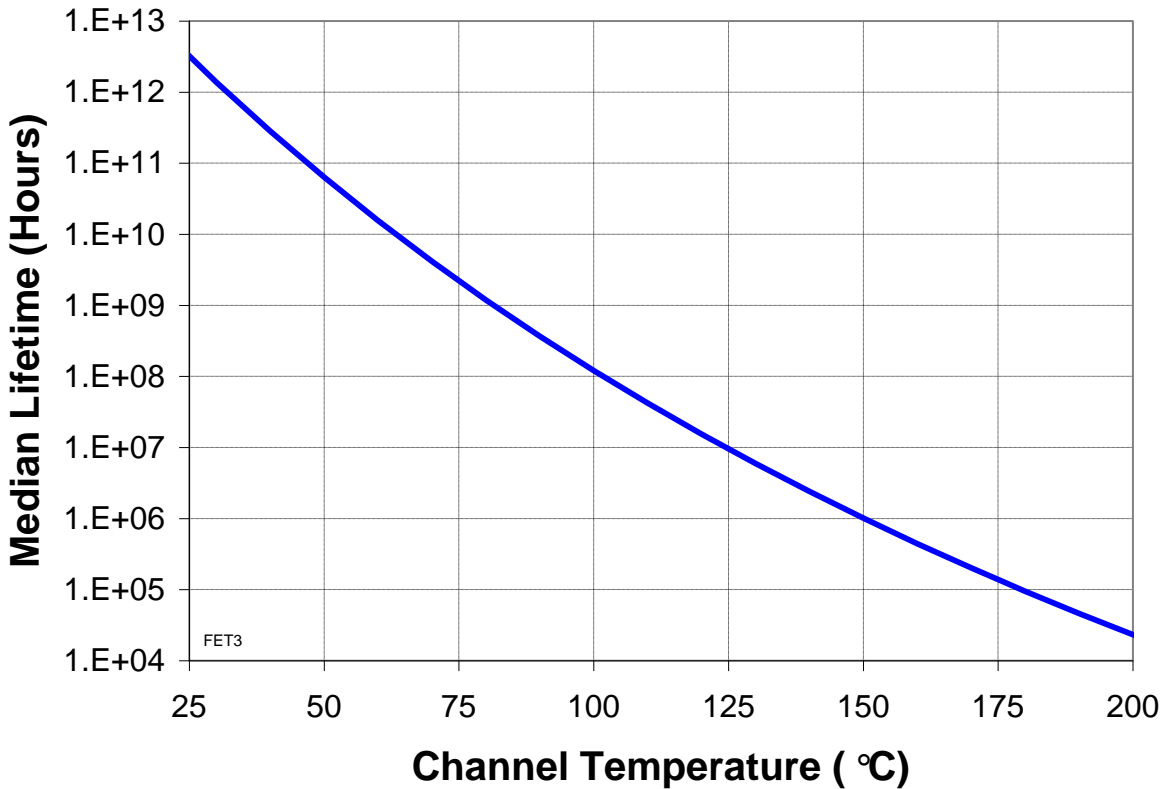

Measured Data

Bias Conditions: $V_d = 6\text{ V}$, $I_d = 770\text{ mA}$ Self Bias

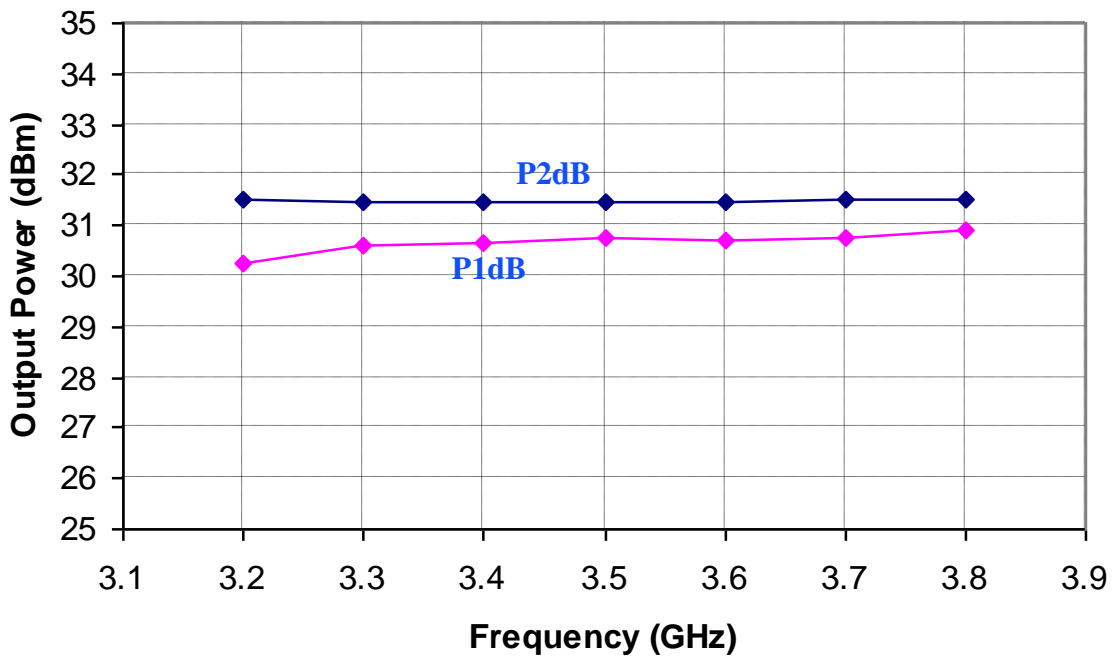
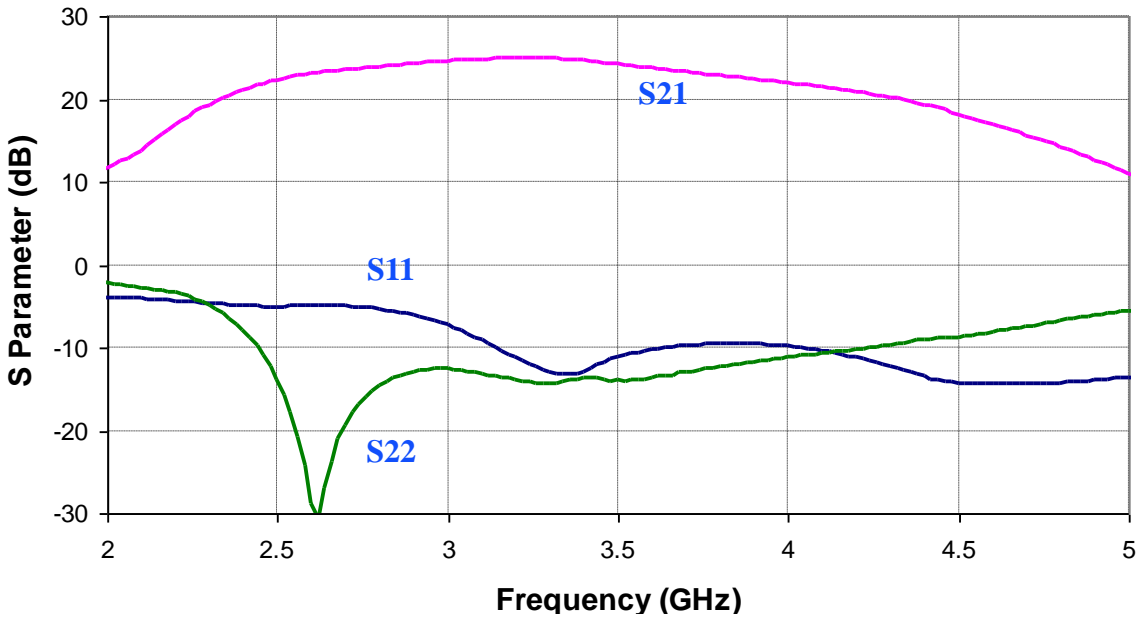

Measured Data

Bias Conditions: $V_d = 6\text{ V}$, $I_d = 770\text{ mA}$ Self Bias

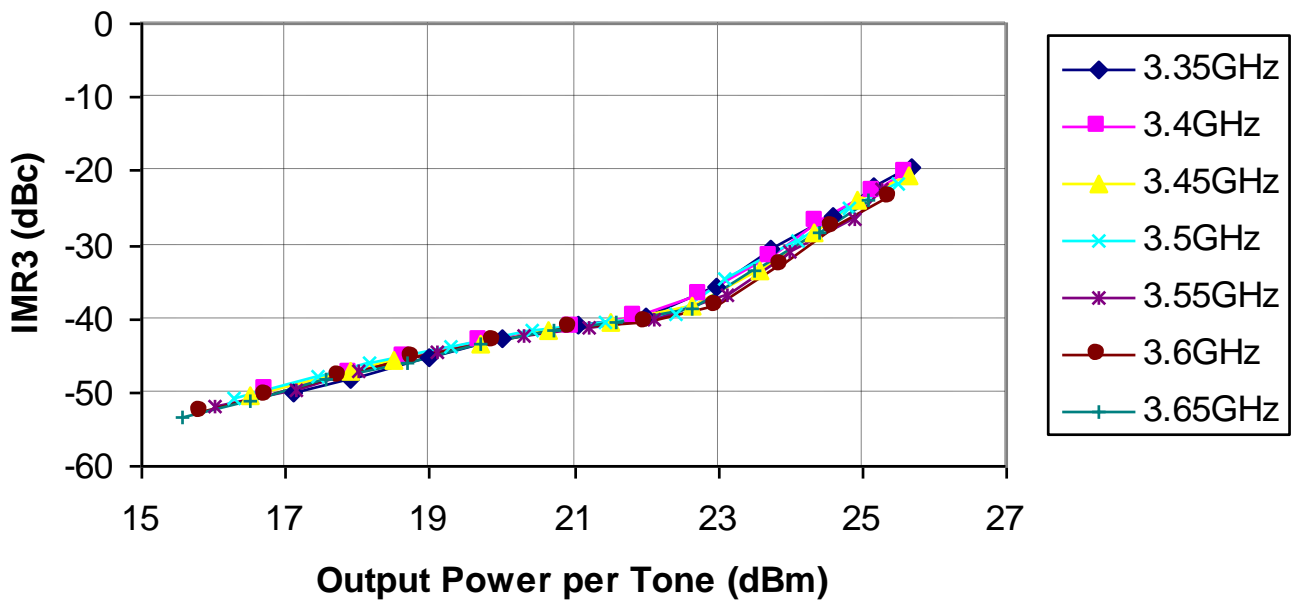
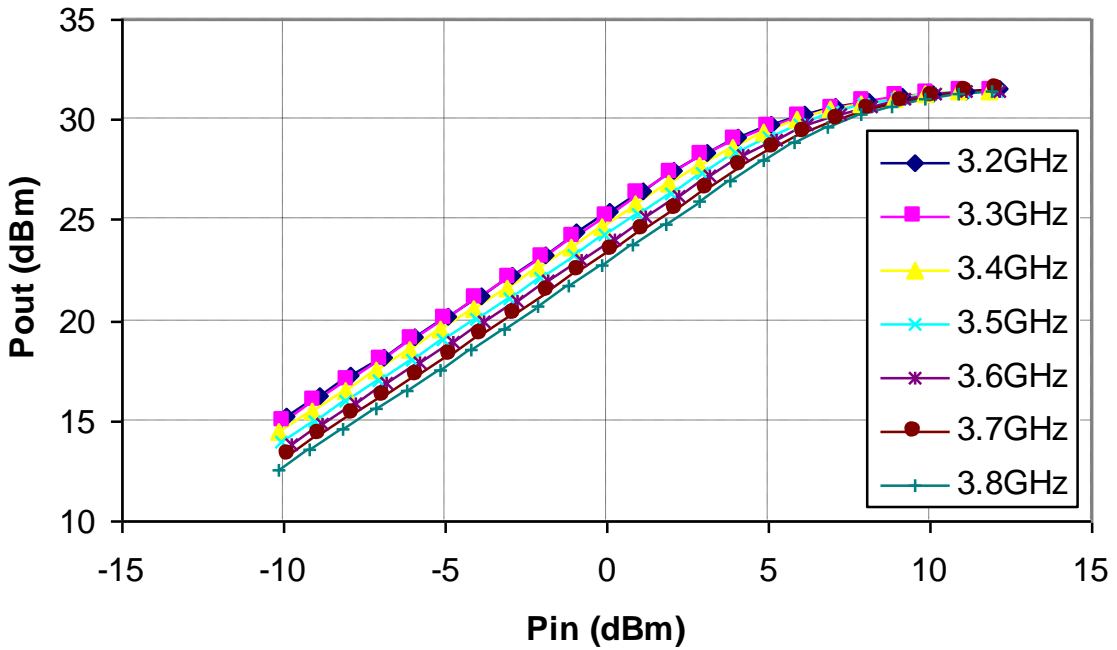

Measured Data

Bias Conditions: $V_d = 6\text{ V}$, $I_d = 770\text{ mA}$ Self Bias

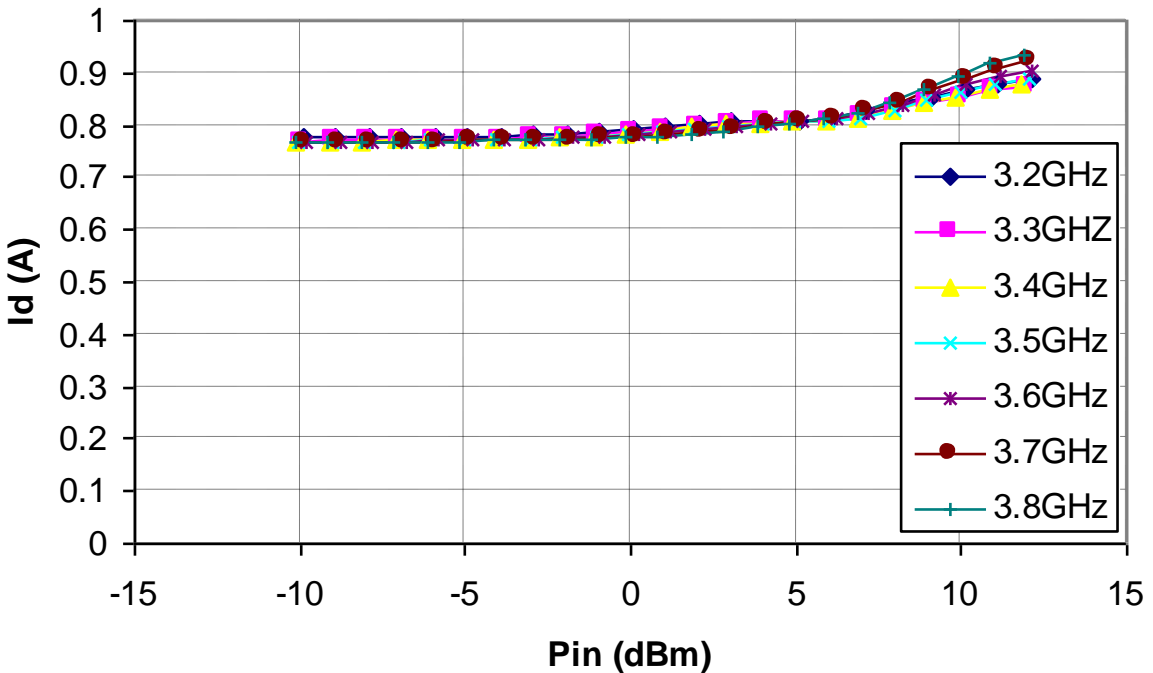
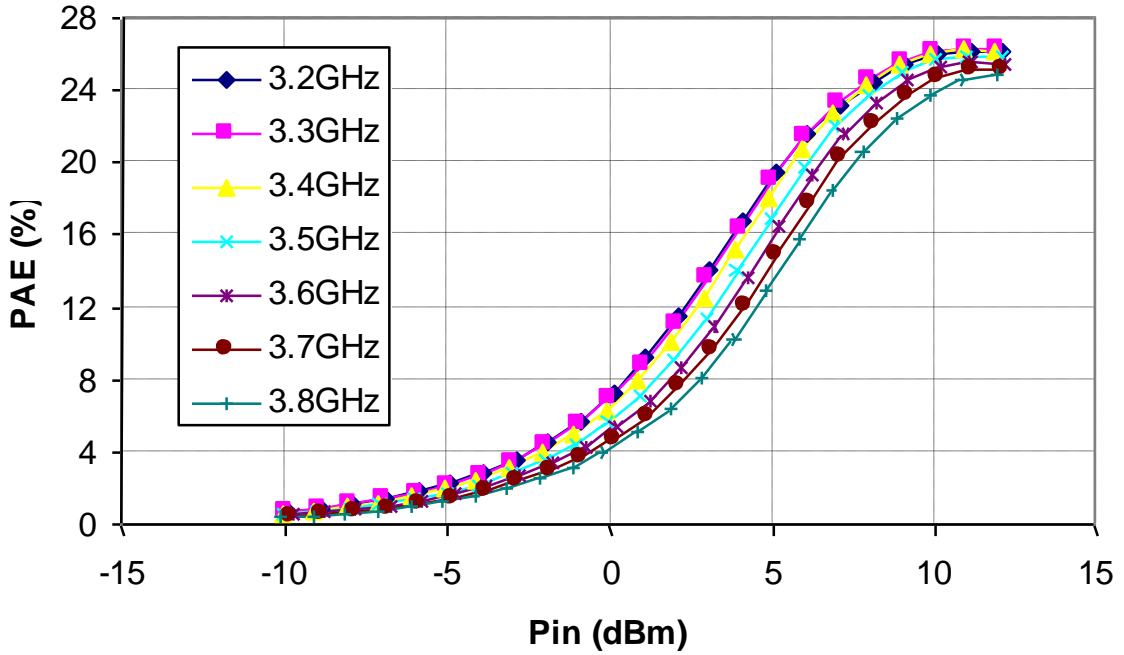

Measured Data

Bias Conditions: $V_d = 6\text{ V}$, $I_d = 770\text{ mA}$ Self Bias

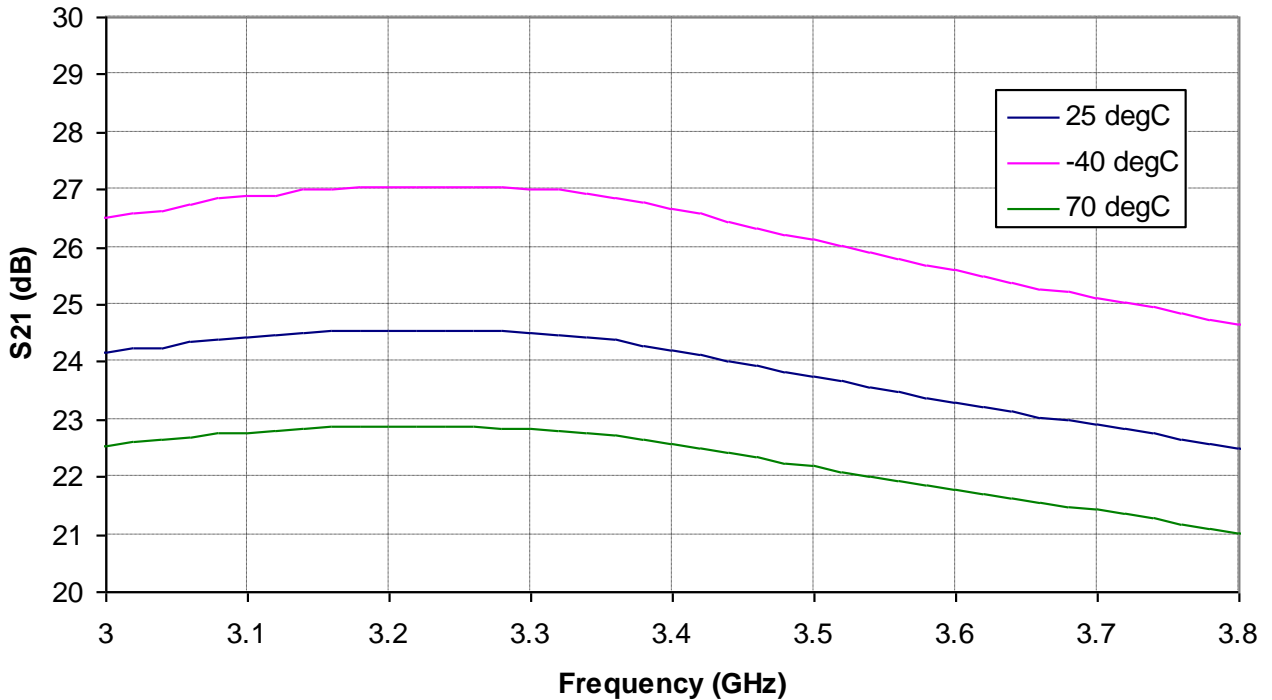

OFDM 64 QAM

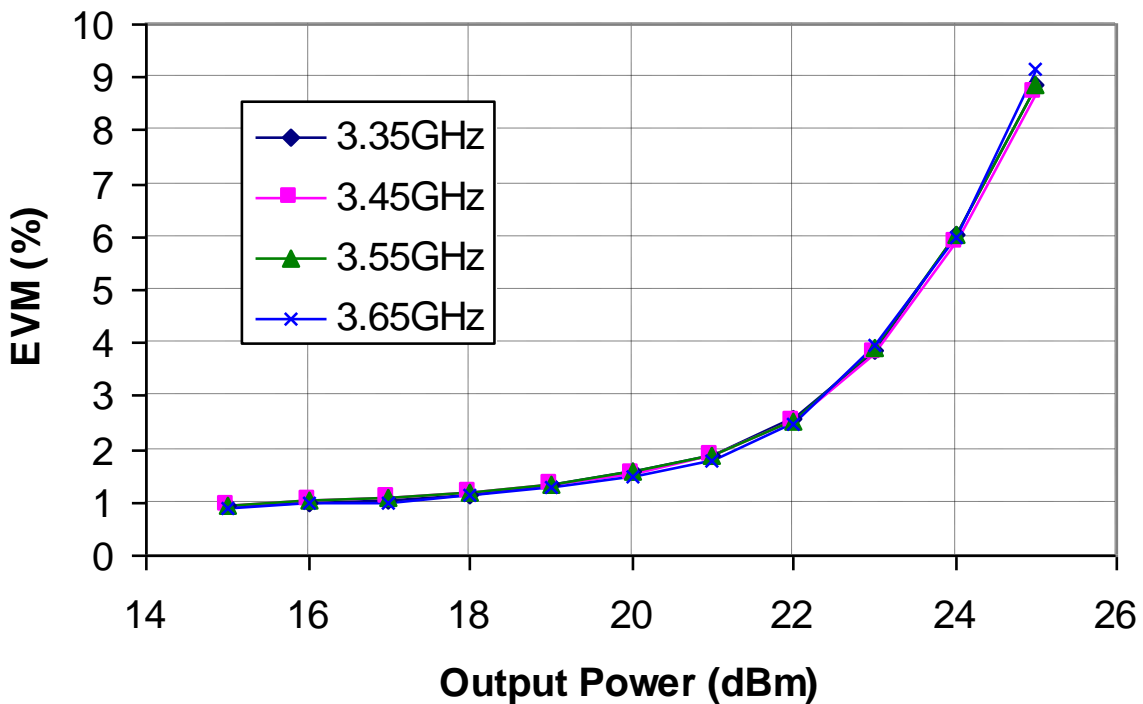

Package Layout

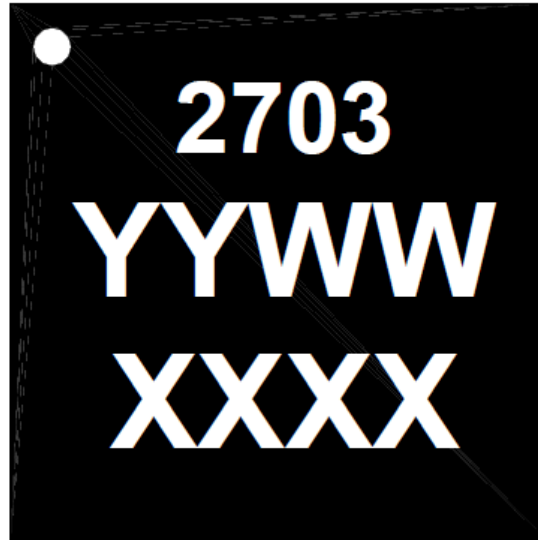

Top View

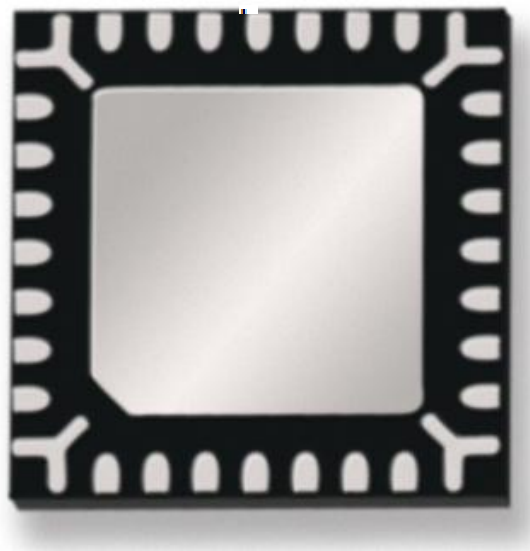

Bottom View

- Details per line
Line 1 : 2703
Line 2 : YYWW - Last 2 digits of the year and the work week.
Line 3: XXXX – 4 digit serial number by the order of assembly lot release to production line.

Package Pinout Diagram

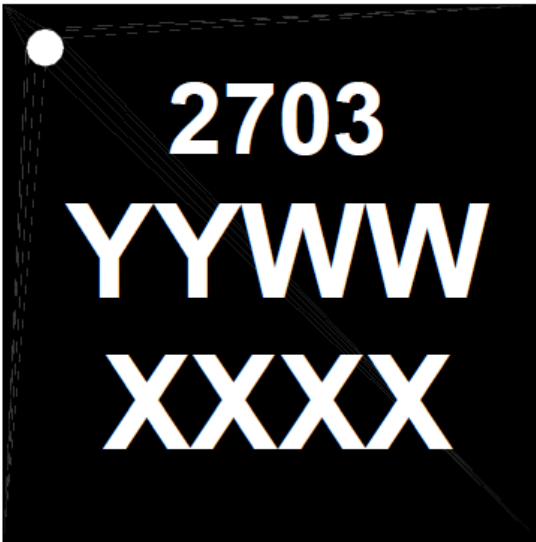

Top Side

Dot indicates Pin 1

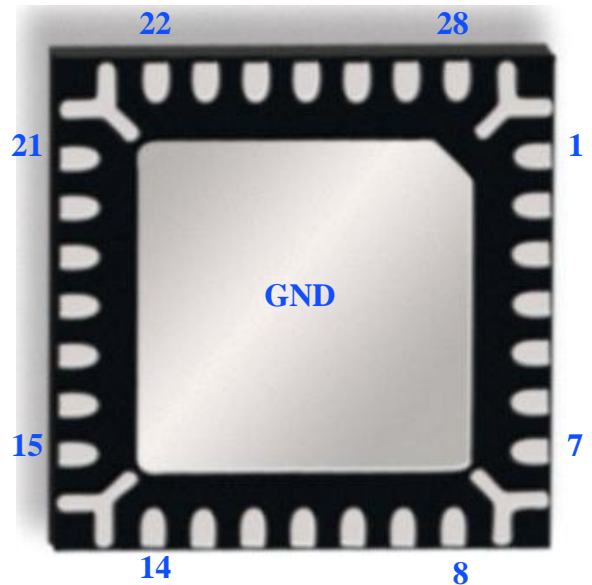

Bottom Side

Pin	Description	Pin	Description
1,2,3	NC	14	Power Sample
4	RF Input	18	RF Output
5,6,7,8,9	NC	19,20,21	NC
10	Gain Control	22	Vd2
11,13	NC	23,24,25	NC
12	Gate Access	26	Vd1
15,16,17	NC	27,28	NC

Mechanical Drawing
(Bottom Side)

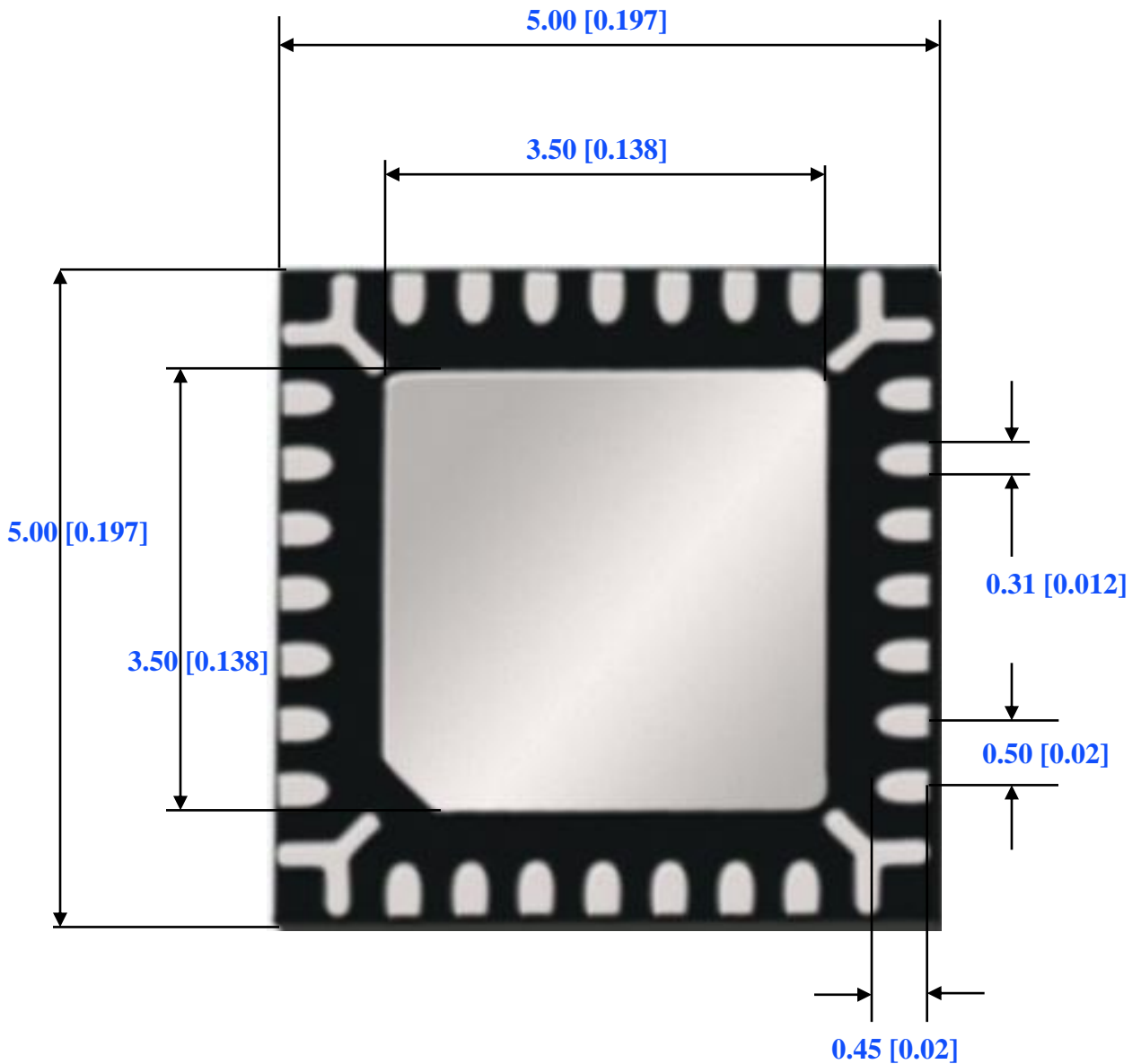

Units: mm [Inch]
Package tolerance: +/- 0.05

Recommended Board Layout Assembly

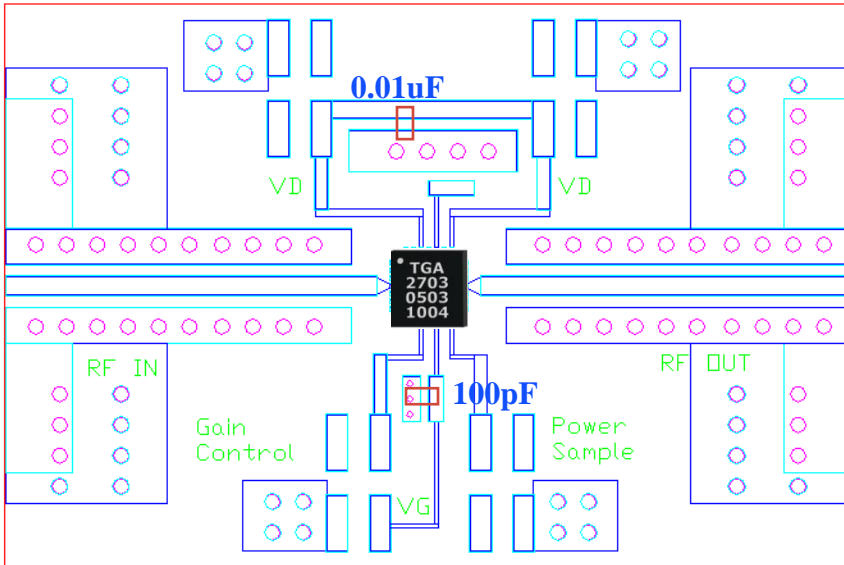

- The evaluation board material is 20 mil thick RO4003
- 100 pF and 0.01 uF are required de-coupling capacitor

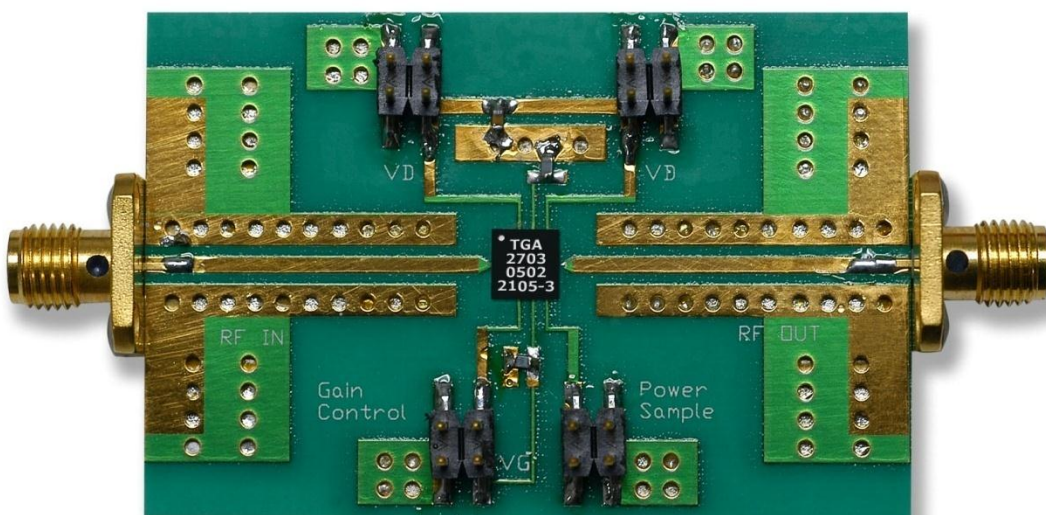

TGA2703 Bias Connection Self-biased mode

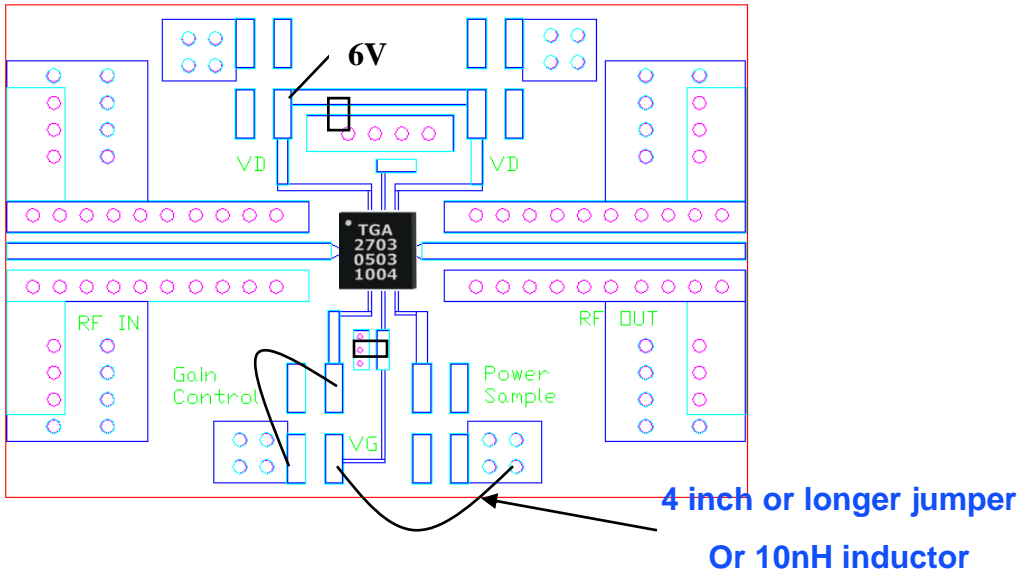

Connect gain control and Vg to ground.
Apply +6V to Vd. Current will be ~770mA

TGA2703 Bias Connection Gate control mode

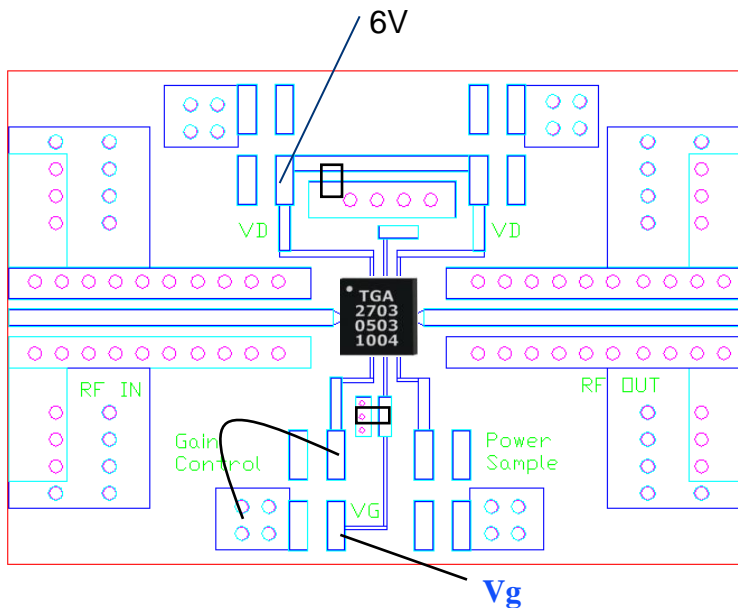

Connect gain control to ground. Apply negative voltage Vg.
Apply +6V to Vd. Current will be ~770mA

TGA2703 Bias Connection Gain control mode

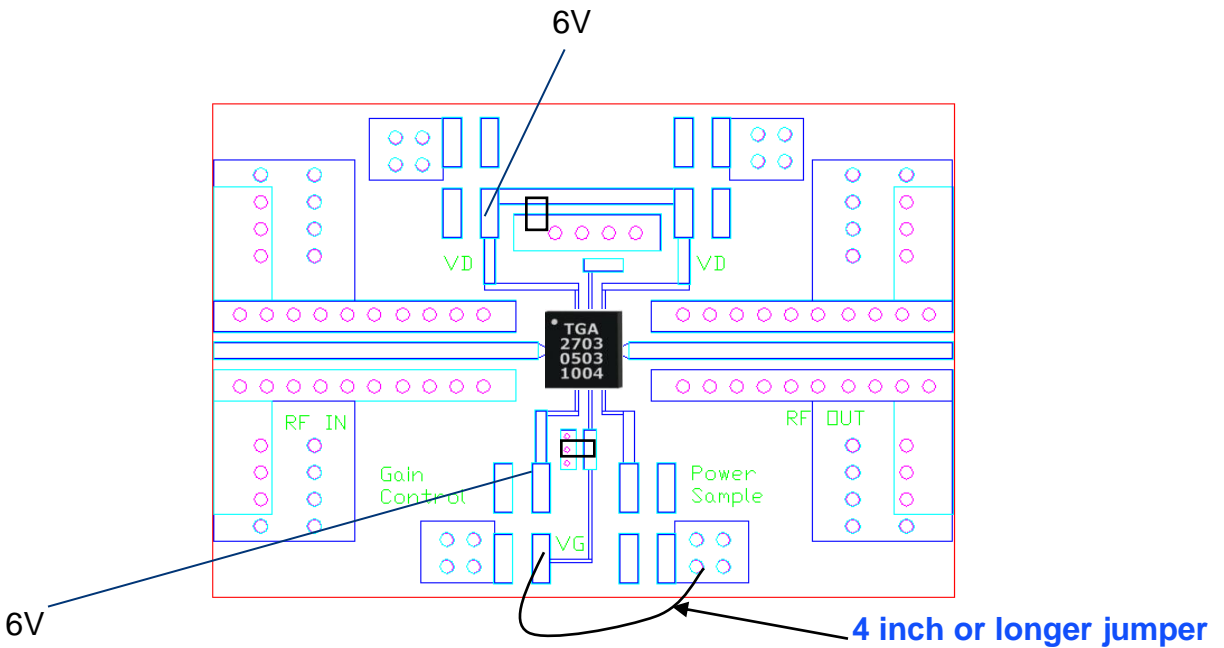

For 13 dB attenuation testing:

or 10nH inductor

Connect gain control to +6V and Vg to ground.
Apply +6V to Vd. Current will be ~770mA

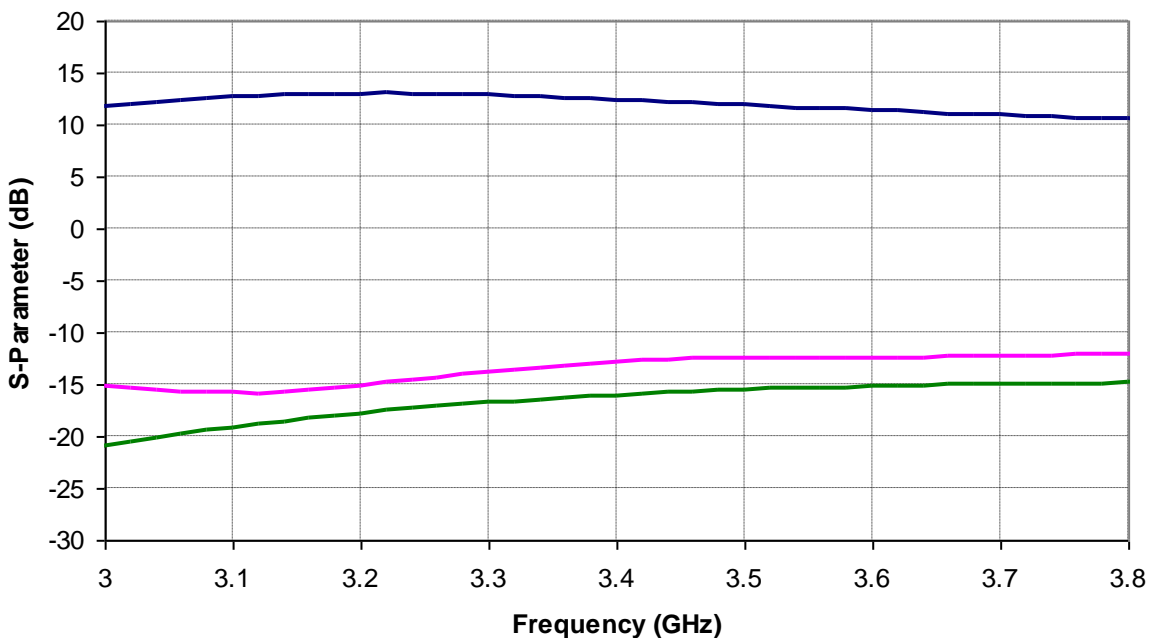

Recommended Surface Mount Package Assembly

Proper ESD precautions must be followed while handling packages.

Clean the board with acetone. Rinse with alcohol. Allow the circuit to fully dry.

TriQuint recommends using a conductive solder paste for attachment. Follow solder paste and reflow oven vendors' recommendations when developing a solder reflow profile. Typical solder reflow profiles are listed in the table below.

Hand soldering is not recommended. Solder paste can be applied using a stencil printer or dot placement. The volume of solder paste depends on PCB and component layout and should be well controlled to ensure consistent mechanical and electrical performance.

Clean the assembly with alcohol.

Typical Solder Reflow Profiles

Reflow Profile	SnPb	Pb Free
Ramp-up Rate	3 °C/sec	3 °C/sec
Activation Time and Temperature	60 – 120 sec @ 140 – 160 °C	60 – 180 sec @ 150 – 200 °C
Time above Melting Point	60 – 150 sec	60 – 150 sec
Max Peak Temperature	240 °C	260 °C
Time within 5 °C of Peak Temperature	10 – 20 sec	10 – 20 sec
Ramp-down Rate	4 – 6 °C/sec	4 – 6 °C/sec

Ordering Information

Part No.	Description
TGA2703-SM	5mm x 5mm QFN
TGA2703-SM T/R	5mm x 5mm QFN, TAPE AND REEL