

## 600mA, 1MHz, Synchronous Step-Up DC-DC Converter

UM3429S SOT23-6

UM3429DA DFN8 2.0×2.0

### General Description

The UM3429 is synchronous rectified, fixed frequency, step-up DC/DC converter series delivering high efficiency in low profile SOT23-6 and DFN8 2.0×2.0 packages. It features true output load disconnection and adjustable output. With an internal NMOS switch, PMOS synchronous rectifier and high switching frequency of 1MHz, the UM3429 is capable of supplying 3.3V output at 100mA from a single AA cell input or 250mA from a 2-cell AA input using low profile inductors and ceramic capacitors.

Current mode PWM control with internal compensation as well as the synchronous rectifier and 1MHz high frequency lead to the fewest number of external parts needed thereby saving BOM cost and PCB area. At light load, UM3429 enters automatically into pulse skipping mode to keep high efficiency. An internal resistor will be connected to  $V_{IN}$  when the switch is idle that eliminates switch ringing and reduces EMI interference.

The device also features low shutdown current lower than 1 $\mu$ A, inrush current limit.

### Applications

- Digital Cameras
- LCD Bias Supplies
- Handheld Instruments
- Wireless Handsets
- GPS Receivers

### Features

- Up to 92% Efficiency
- Output Load Disconnection
- Internal Synchronous Rectifier
- Low Voltage Start-Up: 0.85V
- Input Current Limit
- Pulse Skipping Mode Operation with Typical  $I_Q$  as 40 $\mu$ A
- Shutdown Current Lower than 1 $\mu$ A
- 1MHz Switching Frequency for Low Profile Inductor/Capacitor
- Input Voltage: 0.5V to 5.0V
- Output Voltage: 2.5V to 5.5V
- Anti-Ringing Control to Reduce EMI

### Typical Application Circuit

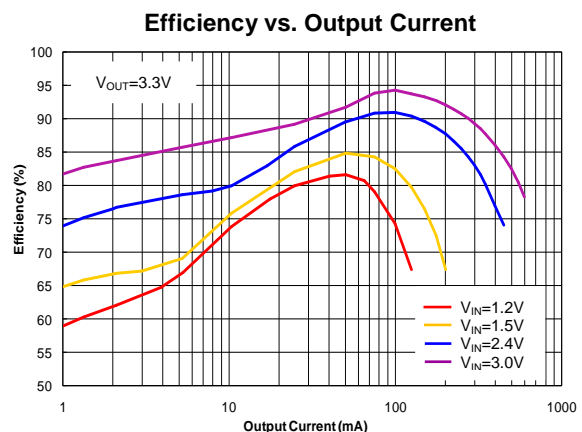
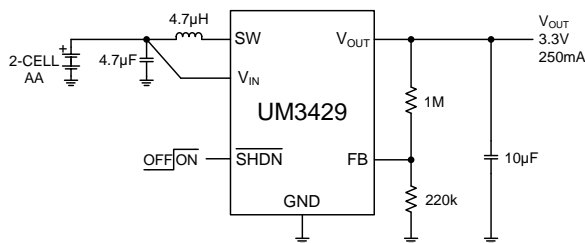

## Pin Configurations

## Top View

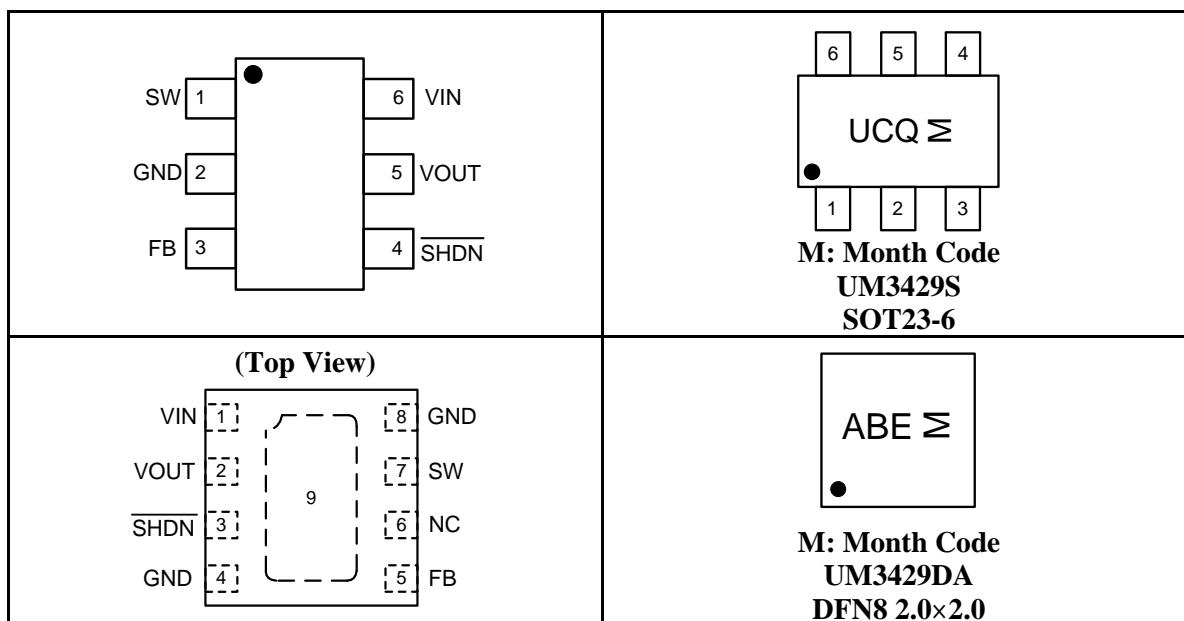

## Pin Description

Pin Number		Symbol	Description
UM3429S	UM3429DA		
1	7	SW	Switch Pin. Connect external inductance to $V_{IN}$ . Keep these PCB trace lengths as short and wide as possible.
2	-	GND	Ground. Provide a short direct PCB path between GND and the negative electrode of $C_{OUT}$ and $C_{IN}$ .
-	4, 8		Ground. Connect the negative electrode of $C_{IN}$ to pin 8 and the negative electrode of $C_{OUT}$ to pin 4.
3	5	FB	Feedback Input Pin. Connect to the center point of the external resistor divider and set the output voltage by: $V_{OUT} = 0.6V \left( 1 + \frac{R1}{R2} \right)$
4	3	$\overline{SHDN}$	Logic Controlled Shutdown Input. Low logic active. In shutdown mode, all functions are disabled drawing $<1\mu A$ supply current. Do not leave $\overline{SHDN}$ floating.
5	2	VOUT	Output Voltage Sense Input and Drain of the Internal Synchronous Rectifier P-MOSFET. Bias is derived from $V_{OUT}$ . Keep PCB trace length from $V_{OUT}$ to the output filter capacitor(s) as short and wide as possible.
6	1	VIN	Battery Input Voltage. The device gets its start-up bias from $V_{IN}$ . Once $V_{OUT}$ exceeds $V_{IN}$ , bias comes from $V_{OUT}$ . Thus, once started, operation is completely independent from $V_{IN}$ . Operation is only limited by the output power level and the battery's internal series resistance.
-	9	Exposed Pad	The exposed pad must be soldered to the PCB ground plane. It serves as an additional ground connection and as a means of conducting heat away from the package.
-	6	NC	Not connected.

**Ordering Information**

Part Number	Packaging Type	Marking Code	Shipping Qty
UM3429S	SOT23-6	UCQ	3000pcs/7Inch Tape & Reel
UM3429DA	DFN8 2.0×2.0	ABE	

**Absolute Maximum Ratings (Note 1)**

Symbol	Parameter	Value	Unit
$V_{IN}$	$V_{IN}$ Supply Voltage	-0.3 to +6.0	V
$V_{SW}$	SW Voltage	-0.3 to +6.0	V
$V_{FB}$	FB Voltage	-0.3 to +6.0	V
$V_{\overline{SHDN}}$	$\overline{SHDN}$ Voltage	-0.3 to +6.0	V
$V_{OUT}$	Output Voltage	-0.3 to +6.0	V
$T_{OP}$	Operating Temperature Range	-40 to +85	°C
$T_{STG}$	Storage Temperature Range	-65 to +150	°C
$T_L$	Maximum Lead Temperature (Soldering , 10s)	+260	°C

Note 1: Maximum ratings are those values beyond which device damage can occur. Maximum ratings applied to the device are individual stress limit values (not normal operating conditions) and are not valid simultaneously. If these limits are exceeded, device functional operation is not implied, damage may occur and reliability may be affected.

**Electrical Characteristics**

 ( $V_{IN}=+1.2V$ ,  $V_{OUT}=+3.3V$ ,  $T_A=+25^{\circ}C$ , unless otherwise noted.)

Parameter	Test Conditions	Min	Typ	Max	Unit
Minimum Start-up Voltage	$I_{LOAD}=1mA$ , $V_{OUT}=0V$		0.85	1	V
Minimum Operating Voltage	$\overline{SHDN}=V_{IN}$ (Note 2)		0.5	0.65	V
Maximum Input Voltage		5			V
Adjustable Output Voltage Range		2.5		5	V
Feedback Voltage		0.595	0.6	0.605	V
Feedback Input Current	$V_{FB}=0.6V$		1	50	nA
Quiescent Current (Pulse Skipping Mode)	$V_{FB}=0.7V$ , $V_{IN}=\overline{SHDN}$ (Note 3)		40		$\mu A$
Quiescent Current (Normal)	$V_{FB}=0.5V$ , $V_{IN}=\overline{SHDN}$ (Note 3)		1.4		mA
Quiescent Current (Shutdown)	$\overline{SHDN}=0V$			1	$\mu A$
NMOS Leakage Current	$V_{SW}=5V$			0.5	$\mu A$
PMOS Leakage Current	$V_{SW}=5V$ , $V_{OUT}=0V$			0.5	$\mu A$
NMOS On-Resistance			0.4		$\Omega$
PMOS On-Resistance			0.5		$\Omega$
NMOS Current limit		600	850		mA
Pulse Skipping Mode Operation Current Threshold	$L=4.7\mu H$		5		mA
Max Duty Cycle		80	90		%
Switching Frequency		0.8	1	1.2	MHz
$\overline{SHDN}$ Input High		1			V
$\overline{SHDN}$ Input Low				0.35	V
$\overline{SHDN}$ Input Current	$\overline{SHDN}=5.5V$		0.01	1	$\mu A$

Note 2: Minimum  $V_{IN}$  operation after start-up is only limited by the battery's ability to provide the necessary power as it enters a deeply discharged state.

Note 3: Pulse skipping mode and normal operation  $I_Q$  is measured at  $V_{OUT}$ . The chip is in the open loop status and the inductor should not be soldered.

**Typical Operating Characteristics**

( $C_{IN}=4.7\mu F$ ,  $C_{OUT}=10\mu F$ ,  $L=4.7\mu H$ ,  $T_A=25^\circ C$ , unless otherwise specified)

**Efficiency vs. Output Current**

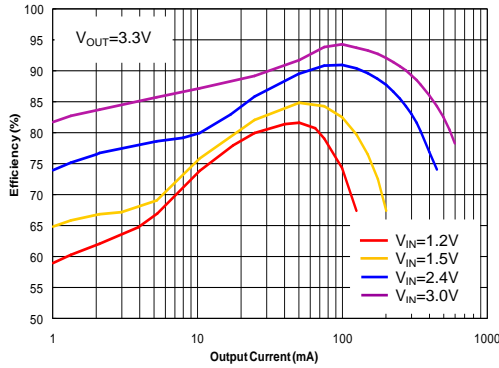

**Efficiency vs. Output Current**

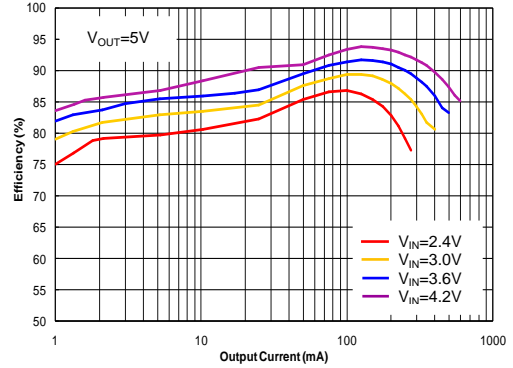

**Output Voltage vs. Output Current**

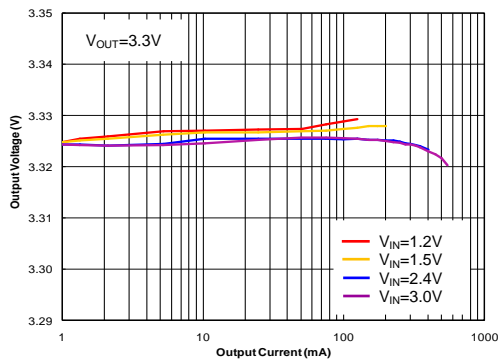

**Output Voltage vs. Output Current**

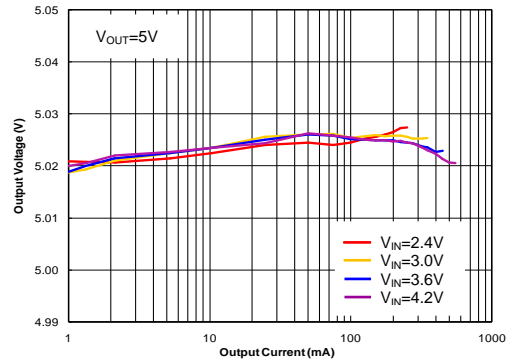

**Efficiency vs. Temp**

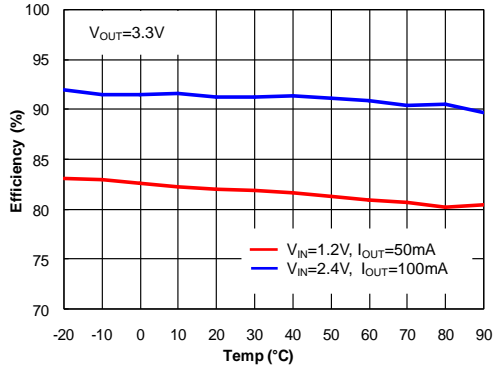

**Output Voltage vs. Temp**

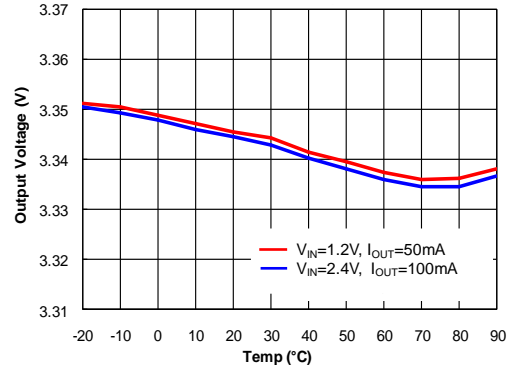

**Minimum Start-up Voltage vs. Current**

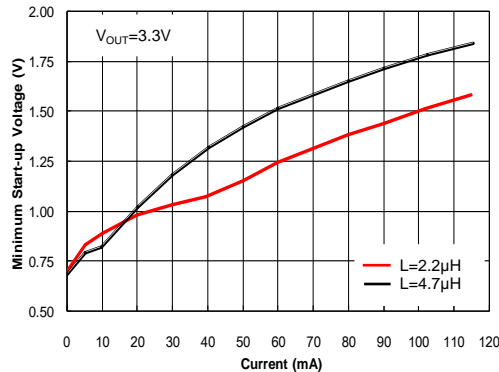

**Pulse Skipping Mode Output Current Threshold vs. Input Voltage**

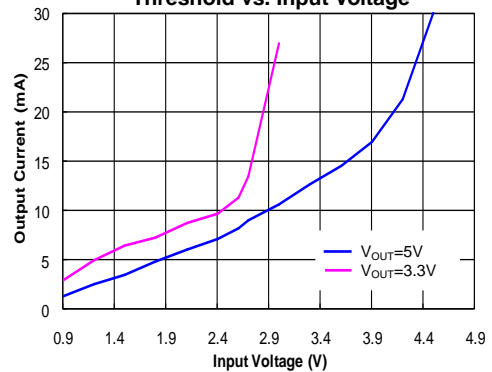

**Typical Operating Characteristics (Continued)**

( $V_{IN}=1.5V$ ,  $V_{OUT}=3.3V$ ,  $C_{IN}=4.7\mu F$ ,  $C_{OUT}=10\mu F$ ,  $L=4.7\mu H$ ,  $T_A=25^\circ C$ , unless otherwise specified)

**SW Pin Normal Mode Operation**

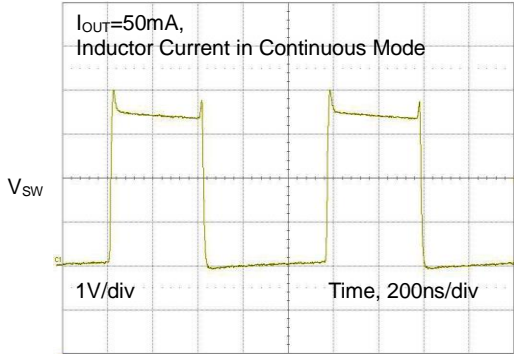

**SW Pin Anti-Ringing Operation**

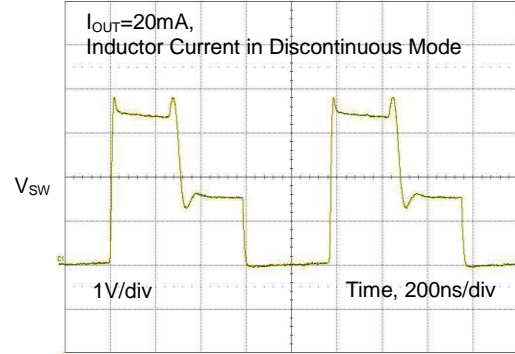

**Line Transient Response**

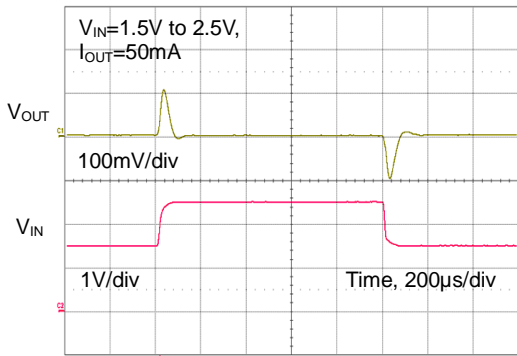

**Load Transient Response**

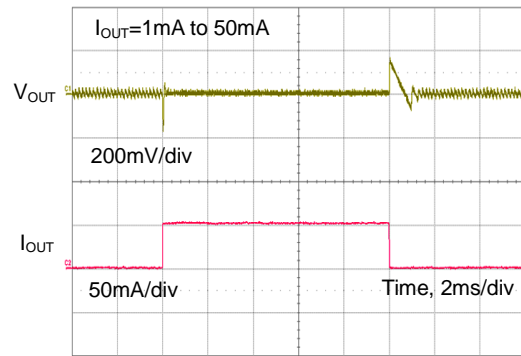

**Pulse Skipping Mode Ripple**

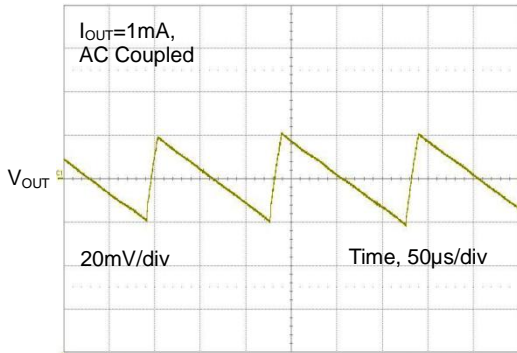

**Ripple and Noise**

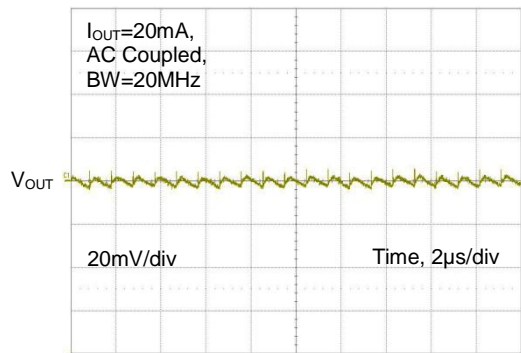

**Ripple and Noise**

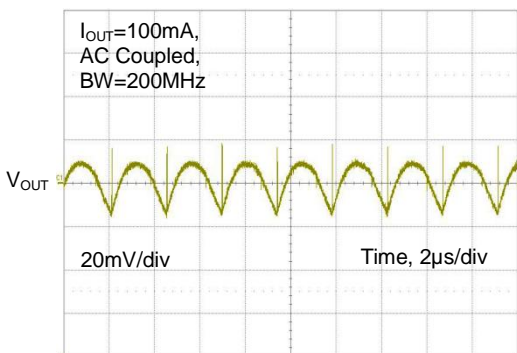

**Ripple and Noise**

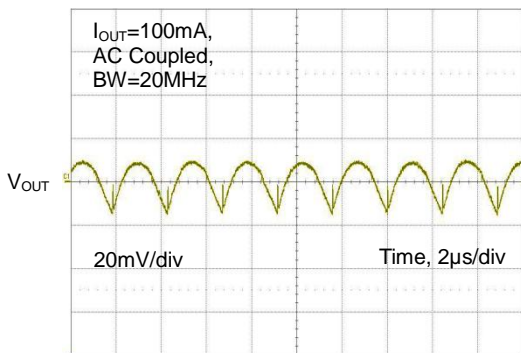

## Block Diagram

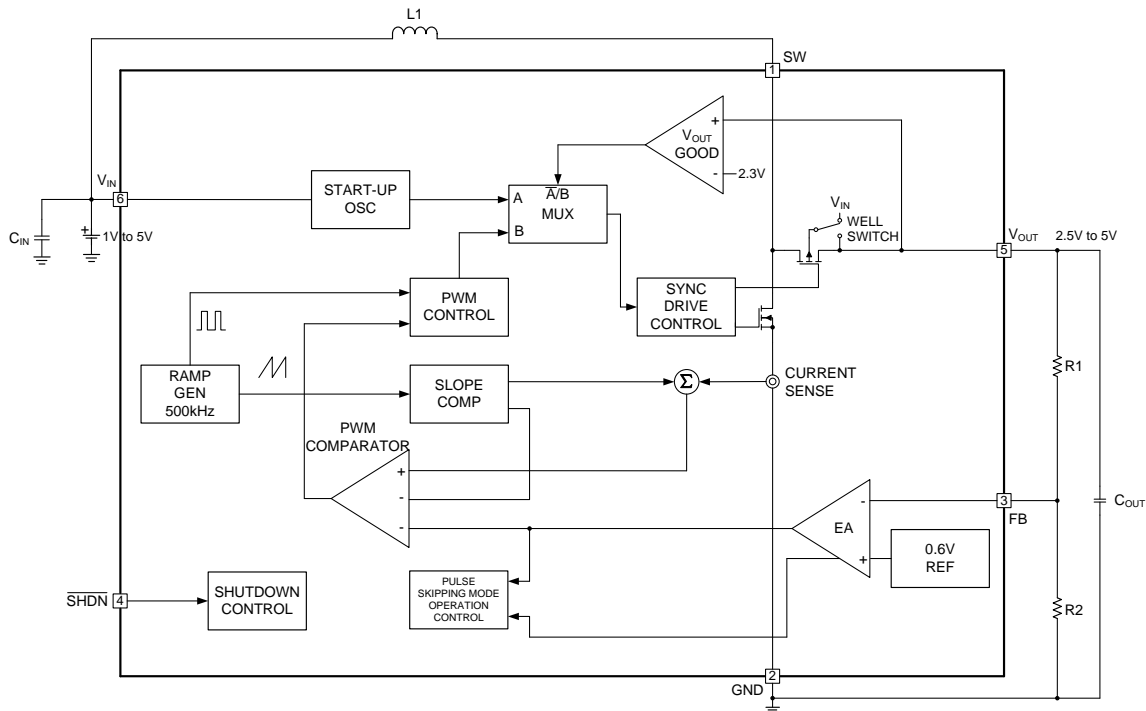

## Function Description

The UM3429 is a synchronous rectified, 1MHz fixed frequency, step-up DC/DC converter in low profile SOT23-6 and DFN8 2.0×2.0 packages. It features start-up voltage low to 0.85V, low  $R_{DS(ON)}$  internal MOSFET switches, current mode PWM controller and 0.6V internal reference voltage. Refer to the Block Diagram for better understanding.

## Low Voltage Start-up

The UM3429 has an independent start-up oscillator. When the input voltage rises to 0.85V, the oscillator starts up. The frequency and duty cycle of the oscillator will be set to a fixed one (Typically: the frequency is 275kHz and the duty is 67%). In this status, the chip is in the open loop operation.

The device gets its start-up bias from  $V_{IN}$ . Once  $V_{OUT}$  exceeds  $V_{IN}$ , bias comes from  $V_{OUT}$ . The chip is still in the open loop operation in this status.

When the output voltage rises to 2.3V, the chip will switch to closed loop. The chip enters normal operation then.

## Anti-Ringing Control

An internal 150Ω resistor will be connected from SW to  $V_{IN}$  to damp resonant circuit formed by L and  $C_{SW}$  when the inductor current is in the discontinuous mode. That eliminates switch ringing and reduces EMI interference.

## Pulse Skipping Mode Operation

At very light loads, the UM3429 automatically enters Pulse Skipping Mode. In the Pulse Skipping Mode, the inductor current may reach zero or reverse on each pulse. The PWM control loop will automatically skip pulses to maintain output regulation. That improves the efficiency of the converter and saves energy of the battery.

## Output Disconnection

The UM3429 is designed to allow true output disconnection by eliminating body diode conduction of the internal PMOS rectifier. This allows  $V_{OUT}$  to go to 0V during shutdown, drawing zero current from the input source. This function is realized by the well switch that connects the substrate to  $V_{IN}$ . Please refer to the Block Diagram for better understanding.

## Applications Information

### Output Voltage Setting

The external resistor divider sets the output voltage. Choose  $R_2$  around 300k $\Omega$  for optimal transient response and feedback leakage current.  $V_{OUT}$  is set by:

$$V_{OUT} = 0.6V \left( 1 + \frac{R_1}{R_2} \right)$$

### Inductor Selection

A 2.2 $\mu$ H to 4.7 $\mu$ H inductor with DC current rating at least 1A is recommended for most applications.

Larger values of inductance will allow greater output current capability by reducing the inductor ripple current. Increasing the inductance above 6.8 $\mu$ H will increase size while providing little improvement in output current capability.

For best efficiency, the inductor DC resistance shall be as small as possible to reduce the  $I^2R$  power losses. As the switching frequency is up to 1MHz, inductor losses are closely related to the magnetic core materials. High frequency ferrite core inductors are preferred to comparatively cheap powdered iron core ones. To minimize radiated noise, use a toroid, pot core or shielded bobbin inductor. See Table 1 for some suggested inductors and suppliers.

**Table 1. Recommended Inductors**

Part	L ( $\mu$ H)	Max DCR (m $\Omega$ )	Height (mm)	Supplier
74404024022	2.2	80	1.2	Würth Elektronik www.we-online.com
74404024033	3.3	120	1.2	
74404024047	4.7	175	1.2	
74404024068	6.8	300	1.2	
74404032047	4.7	96	1.5	
74404032068	6.8	120	1.5	
CDRH3D16-4R7	4.7	105	1.8	Sumida www.sumida.com
CR43-4R7	4.7	109	3.5	
DS1608-472	4.7	60	2.9	Coilcraft www.coilcraft.com
DO1608C-472	4.7	90	2.9	
LQH32CN4R7M24	4.7	195	2.2	Murata www.murata.com
LQM21PN4R7MGHL	4.7	275	0.9	

## Input and Output Capacitor Selection

Low ESR capacitors should be used to minimize the output voltage ripple, input switching noise and the peak current drawn from the battery. Multilayer ceramic capacitors are an excellent choice as they have extremely low ESR and are available in small footprints. X5R and X7R dielectric materials are recommended.

A 4.7 $\mu$ F to 10 $\mu$ F input and output capacitor is sufficient for most applications. To minimize the output voltage ripple and improve the transient response, an output capacitor up to 22 $\mu$ F or larger can be used. Table 2 below shows a list of several ceramic capacitor suppliers.

**Table 2. Recommended Capacitor Suppliers Information**

Supplier	Website
AVX	<a href="http://www.avxcorp.com">www.avxcorp.com</a>
Murata	<a href="http://www.murata.com">www.murata.com</a>
Fenghua	<a href="http://www.china-fenghua.com">www.china-fenghua.com</a>
Samsung Electro-Mechanics	<a href="http://www.samsungsem.com">www.samsungsem.com</a>

## Layout Guidance

When laying out the PC board, the following suggestions should be taken to ensure proper operation of the UM3429.

1. Consideration should be taken first to place  $C_{OUT}$  as closely as possible to the  $V_{OUT}$  and GND pins.
2. The power traces, including the GND, SW,  $V_{IN}$  and  $V_{OUT}$  should be kept short, direct and wide to allow large current flow.
3. Connect the input capacitor  $C_{IN}$  to the GND pin as closely as possible to get good power filter effect and reduce ground bounce.
4. Keep the switching node away from the sensitive FB node.
5. Do not trace signal line under inductor.
6. Keep the GND plane under the converter as complete as possible in double-sided PCB board.
7. For the UM3429DA, connect pin 4, 8 and the expose pad together to the ground plane by vias to conduct the heat away from the package.

## Package Information

### UM3429S: SOT23-6

#### Outline Drawing

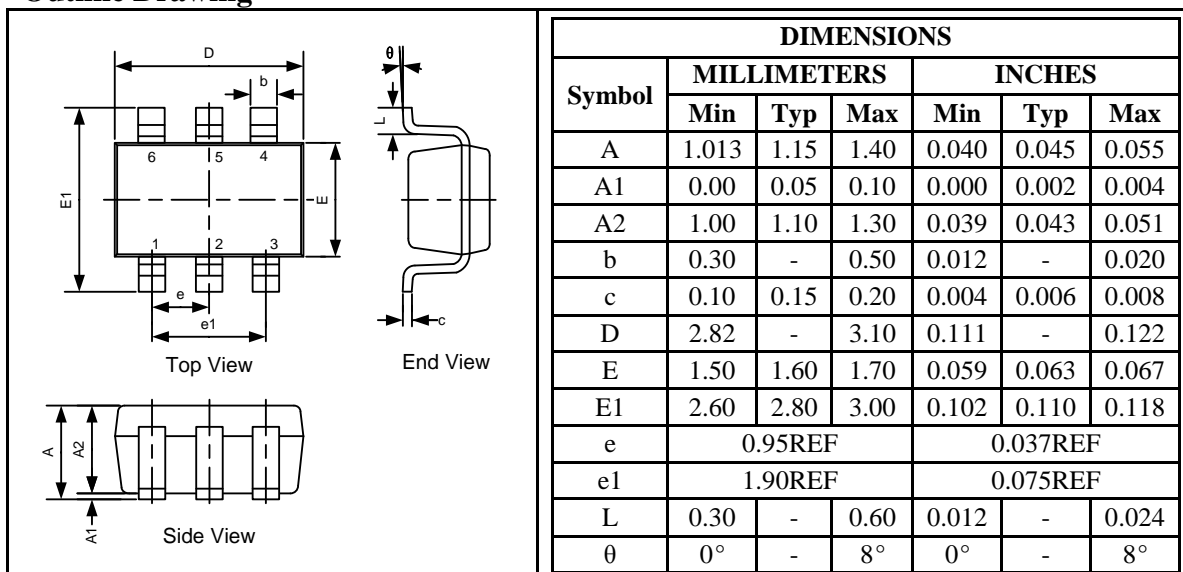

#### Land Pattern

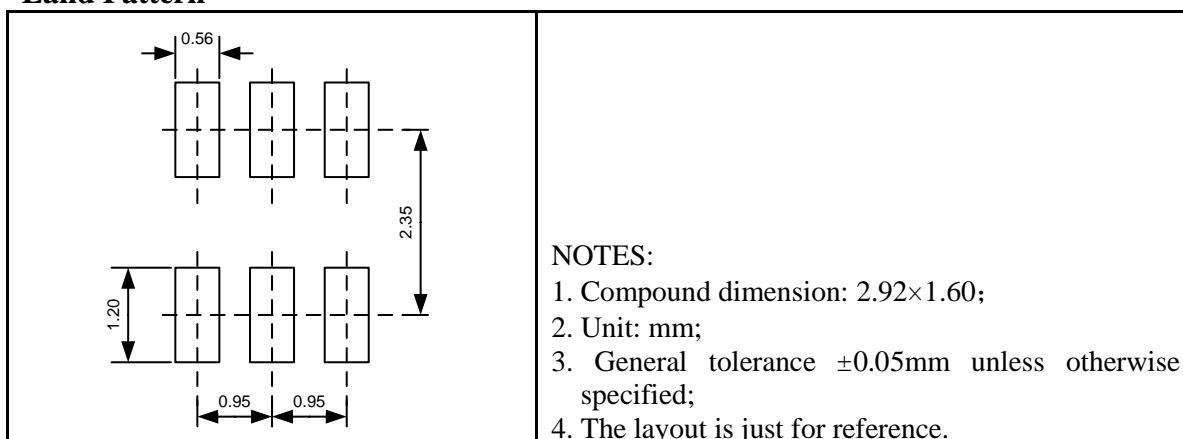

#### Tape and Reel Orientation



## UM3429DA: DFN8 2.0×2.0

### Outline Drawing

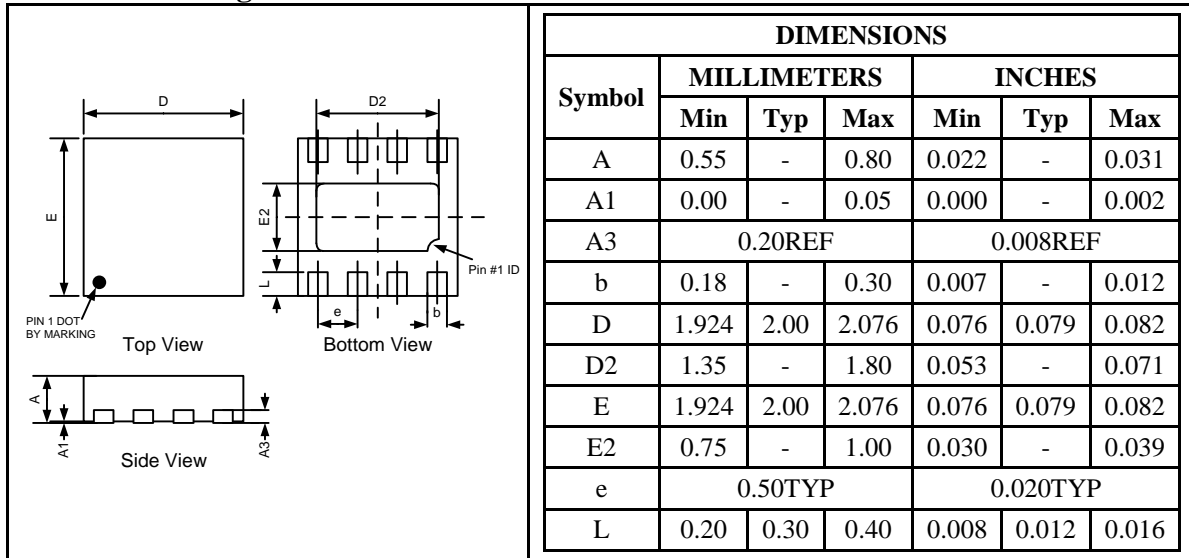

### Land Pattern

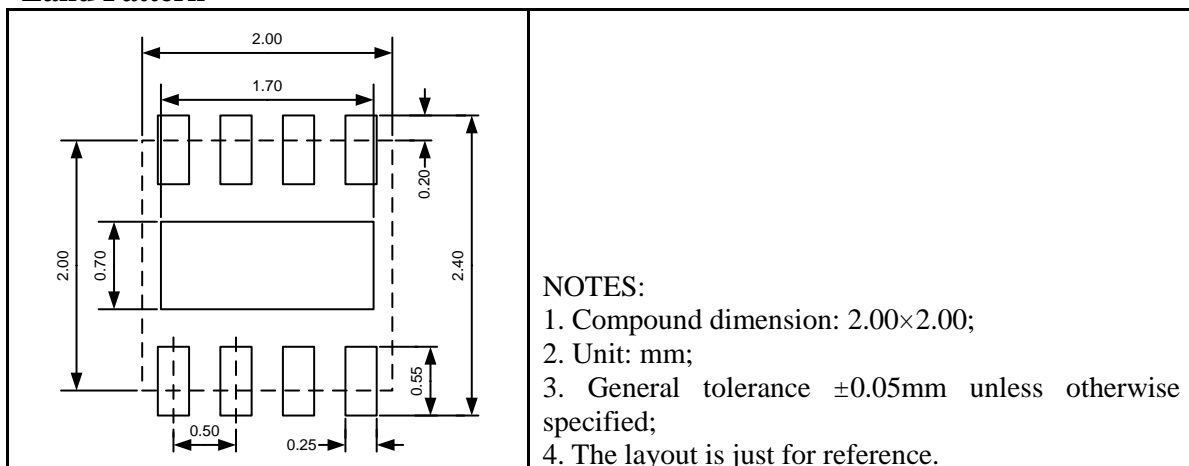

### Tape and Reel Orientation

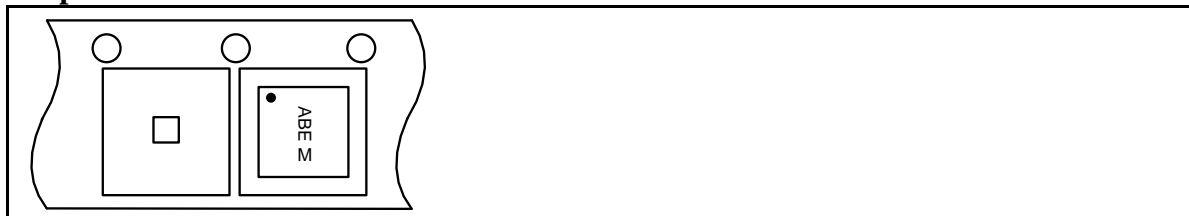

---

## **GREEN COMPLIANCE**

Union Semiconductor is committed to environmental excellence in all aspects of its operations including meeting or exceeding regulatory requirements with respect to the use of hazardous substances. Numerous successful programs have been implemented to reduce the use of hazardous substances and/or emissions.

All Union components are compliant with the RoHS directive, which helps to support customers in their compliance with environmental directives. For more green compliance information, please visit:

[http://www.union-ic.com/index.aspx?cat\\_code=RoHSDeclaration](http://www.union-ic.com/index.aspx?cat_code=RoHSDeclaration)

## **IMPORTANT NOTICE**

The information in this document has been carefully reviewed and is believed to be accurate. Nonetheless, this document is subject to change without notice. Union assumes no responsibility for any inaccuracies that may be contained in this document, and makes no commitment to update or to keep current the contained information, or to notify a person or organization of any update. Union reserves the right to make changes, at any time, in order to improve reliability, function or design and to attempt to supply the best product possible.



Union Semiconductor, Inc

Add: Unit 606, No.570 Shengxia Road, Shanghai 201210

Tel: 021-51093966

Fax: 021-51026018

Website: [www.union-ic.com](http://www.union-ic.com)