



EQUALIZER CARRADIO SIGNAL PROCESSOR

- 3 STEREO INPUTS
- 3 MONO INPUTS
- DYNAMIC-COMPRESSION-STAGE FOR CD
- BASS, TREBLE AND LOUDNESS CONTROL
- EQ-FILTERS FOR SEPARATE FRONT/REAR-EQUALIZATION
- VOICE-BAND-FILTER FOR MIXING-CHANNEL
- DIRECT MUTE AND SOFTMUTE
- INTERNAL BEEP
- FOUR INDEPENDENT SPEAKER-OUTPUTS
- INDEPENDENT SECOND SOURCE-SELECTOR
- FULL MIXING CAPABILITY
- PAUSE DETECTOR

Stereodecoder

- RDS MUTE
- NO EXTERNAL ADJUSTMENTS
- AM/FM NOISEBLANKER WITH SEVERAL TRIGGER CONTROLS
- PROGRAMMABLE MULTIPATH DETECTOR
- QUALITY DETECTOR OUTPUT

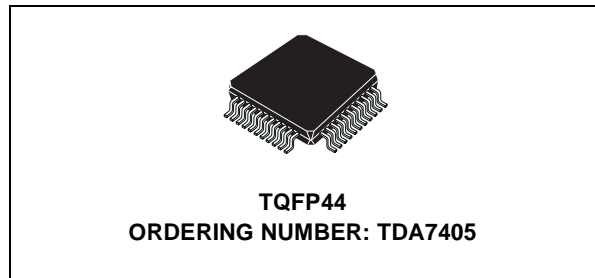

Digital control:

- I²C-BUS INTERFACE

DESCRIPTION

The device includes a high performance audioprocessor and a stereodecoder-noiseblanker combination with the whole low frequency signal processing necessary for state-of-the-art as well as future carradios. The digital control allows a programming in a wide range of all the filter characteristics. Also the stereodecoder part offers several possibilities of programming especially for the adaptation to different IF-devices.

BLOCK DIAGRAM

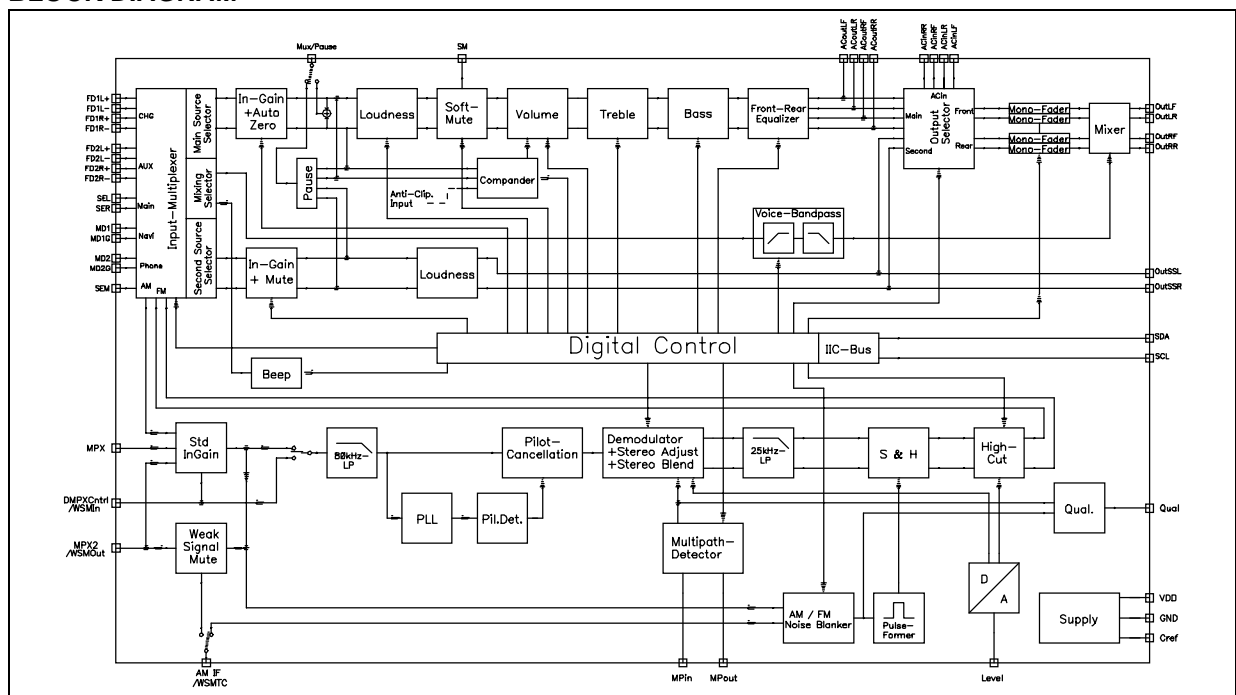

TDA7405

SUPPLY

Symbol	Parameter	Test Condition	Min.	Typ.	Max.	Unit
V _s	Supply Voltage		7.5	9	10.5	V
I _s	Supply Current	V _s = 9V	45	65	85	mA
SVRR	Ripple Rejection @ 1KHz	Audioprocessor(all Filters flat)		60		dB
		Stereodecoder + Audioprocessor		55		dB

THERMAL DATA

Symbol	Parameter	Value	Unit
R _{Th j-pins}	Thermal Resistance Junction-pins max	65	°C/W

ABSOLUTE MAXIMUM RATINGS

Symbol	Parameter	Value	Unit
V _s	Operating Supply Voltage	10.5	V
T _{amb}	Operating Temperature Range	-40 to 85	°C
T _{stg}	Storage Temperature Range	-55 to +150	°C

ESD

All pins are protected against ESD according to the MIL883 standard.

PIN CONNECTION (Top view)

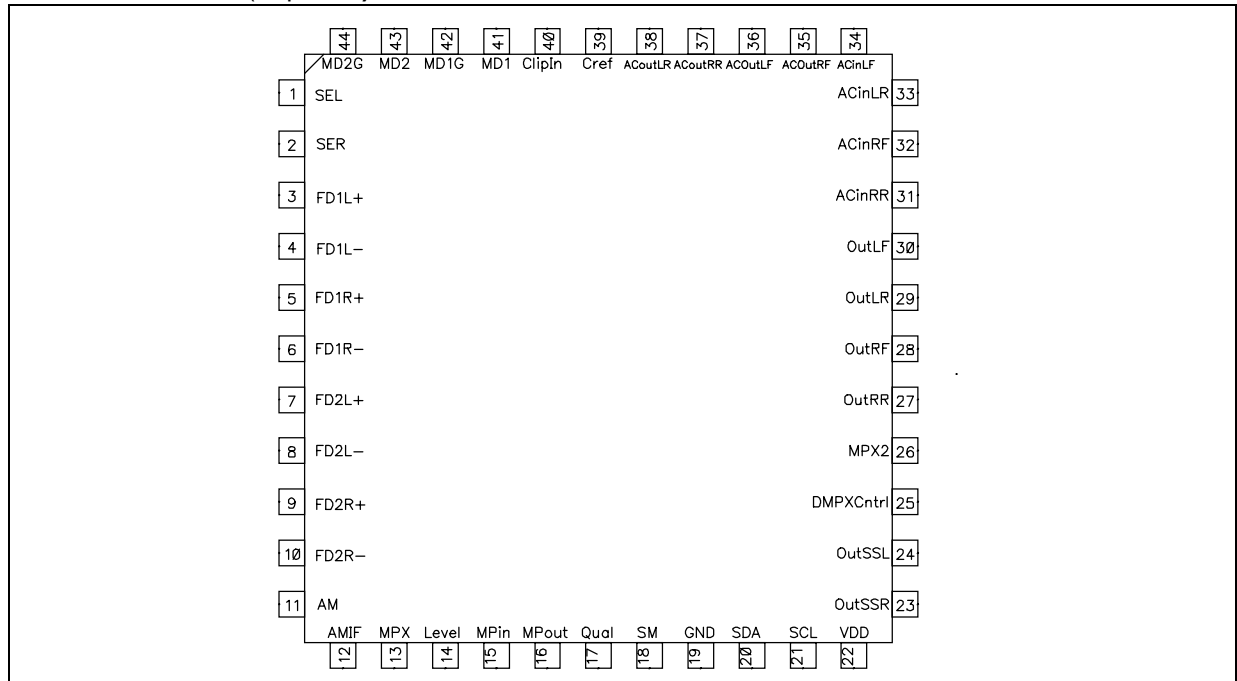

BLOCK DIAGRAM (Enlarged view)

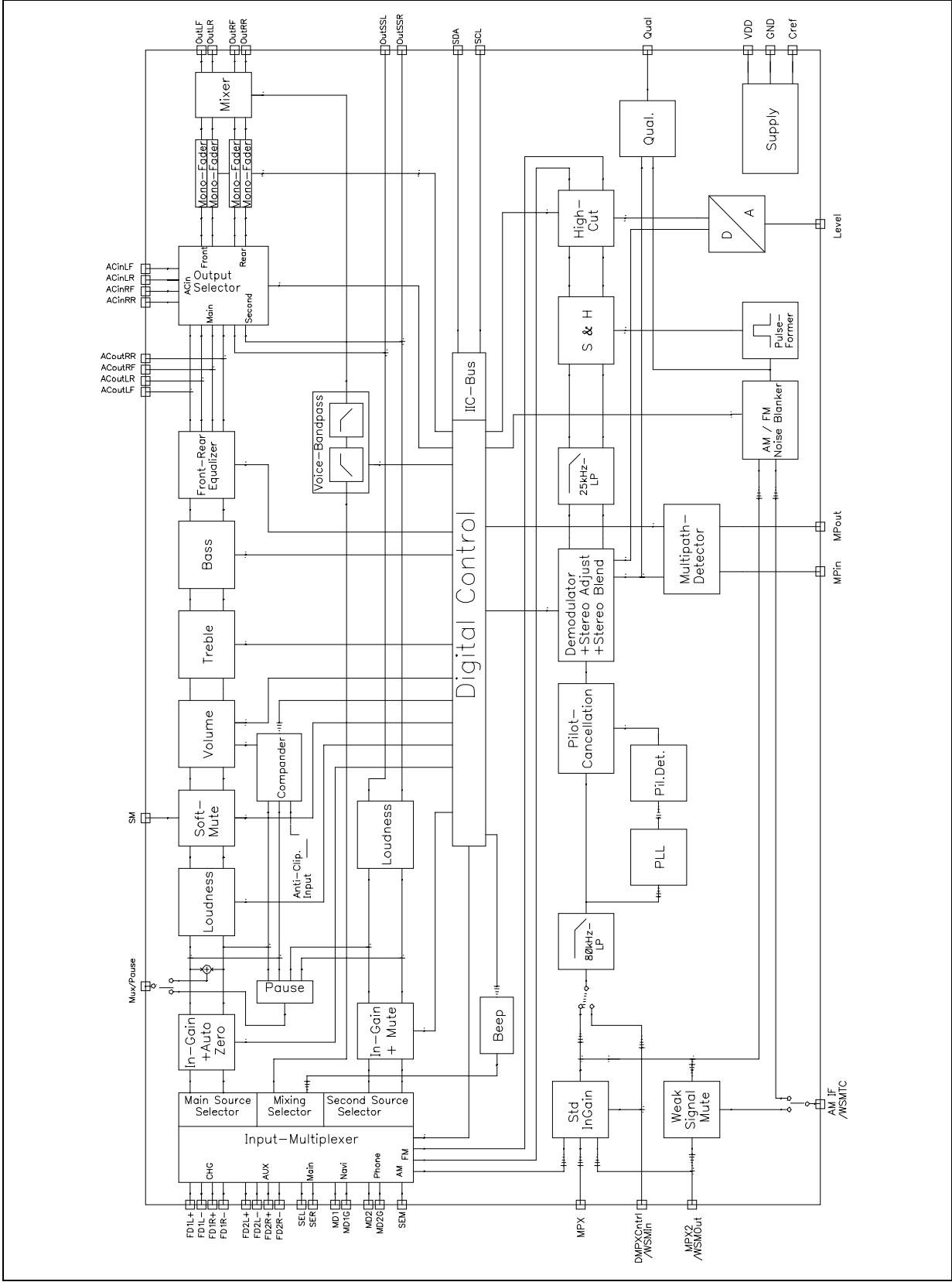

1 AUDIOPROCESSOR PART**Features:**

Input Multiplexer	2 fully differential CD stereo inputs with programmable attenuation 1 single-ended stereo input 2 differential mono input 1 single-ended mono input In-Gain 0..15dB, 1dB steps internal Offset-cancellation (AutoZero) separate second source-selector
Beep	internal Beep with 3 frequencies + diagnostic setting (19kHz tone)
Mixing stage	Beep, Phone, Navigation and FM mixable to all speaker-outputs (see Figure 20) programmable Voice-Band Filter
Loudness	programmable center frequency and frequency response 15 x 1dB steps selectable flat-mode (constant attenuation)
Volume	0.5dB attenuator 100dB range soft-step control with programmable times
Bass	2nd order frequency response center frequency programmable in 8 steps DC gain programmable ± 15 x 1dB steps
Treble	2nd order frequency response center frequency programmable in 4 steps ± 15 x 1dB steps
Equalizer	two stereo equalizing-filters for separate front/rear adaption 1st filter center-frequency programmable in 16 steps (4 steps/octave, min 63Hz, max 840Hz) 2nd filter center-frequency programmable in 16 steps (4 steps/octave, min 300Hz, max 4kHz) quality factor programmable in 4 steps ± 15 x 1dB steps selectable flat-mode
Speaker	4 independent speaker controls in 1dB steps control range 95dB separate Mute
Mute Functions	direct mute digitally controlled SoftMute with 4 programmable mute-times
Pause Detector	programmable threshold
Compander	dynamic range compression for use with CD 2:1 compression rate programmable max. gain

Table 1. ELECTRICAL CHARACTERISTICS(V_S=9V; T_{amb}=25°C; R_L=10kΩ; all gains=0dB; f=1kHz; unless otherwise specified)

Symbol	Parameter	Test Condition	Min.	Typ.	Max.	Unit
INPUT SELECTOR						
R _{in}	Input Resistance	all single ended Inputs	70	100	130	kΩ
V _{CL}	Clipping Level		2.2	2.6		V _{RMS}
S _{IN}	Input Separation		80	100		dB
G _{IN MIN}	Min. Input Gain		-1	0	+1	dB
G _{IN MAX}	Max. Input Gain		13	15	17	dB
G _{STEP}	Step Resolution		0.5	1	1.5	dB
V _{DC}	DC Steps	Adjacent Gain Steps	-5	1	5	mV
		G _{MIN} to G _{MAX}	-10	1	10	mV
V _{offset}	Remaining offset with AutoZero			0.5		mV
DIFFERENTIAL STEREO INPUTS						
R _{in}	Input Resistance (see Fig. 1)	Differential	70	100	130	kΩ
G _{CD}	Gain	only at true differential input	-1	0	1	dB
			-5	-6	-7	dB
			-11	-12	-13	dB
CMRR	Common Mode Rejection Ratio	V _{CM} = 1V _{RMS} @ 1kHz	46	70		dB
		V _{CM} = 1V _{RMS} @ 10kHz	46	60		dB
e _{NO}	Output-Noise @ Speaker-Outputs	20Hz - 20kHz, flat; all stages 0dB		9	15	μV
DIFFERENTIAL MONO INPUTS						
R _{in}	Input Impedance	Differential	40	56	72	kΩ
CMRR	Common Mode Rejection Ratio	V _{CM} = 1V _{RMS} @ 1kHz	46	70		dB
		V _{CM} = 1V _{RMS} @ 10kHz	46	60		dB
BEEP CONTROL						
V _{RMS}	Beep Level	Mix-Gain = 6dB	250	350 ¹⁾	500	mV
f _{Beep}	Beep Frequency	f _{Beep1}	470	500	530	Hz
		f _{Beep2}	740	780	820	Hz
		f _{Beep3}	1.7	1.8	1.9	kHz
		f _{Beep4}	18	19	20	kHz
1. The Level for the 19kHz-Testtone is 2.1V _{RMS}						
MIXING CONTROL						
M _{LEVEL}	Mixing Ratio	Main / Mix-Source		-6/-6		dB
G _{MAX}	Max. Gain		13	15	17	dB
A _{MAX}	Max. Attenuation		-83	-79	-75	dB
A _{STEP}	Attenuation Step		0.5	1	1.5	dB

Table 1. ELECTRICAL CHARACTERISTICS (continued)

(V_S=9V; T_{amb}=25°C; R_L=10kΩ; all gains=0dB; f=1kHz; unless otherwise specified)

Symbol	Parameter	Test Condition	Min.	Typ.	Max.	Unit
MULTIPLEXER OUTPUT²⁾						
R _{OUT}	Output Impedance			800	1000	Ω
R _L	Output Load Capacitance		2			kΩ
C _L					10	nF
V _{DC}	DC Voltage Level		4.3	4.5	4.7	V

2. If configured as Multiplexer-Output

LOUDNESS CONTROL

A _{STEP}	Step Resolution		0.5	1	1.5	dB
A _{MAX}	Max. Attenuation		-21	-19	-17	dB
f _{Peak}	Peak Frequency	f _{P1}	180	200	220	Hz
		f _{P2}	360	400	440	Hz
		f _{P3}	540	600	660	Hz
		f _{P4}	720	800	880	Hz

VOLUME CONTROL

G _{MAX}	Max. Gain		30	32	34	dB
A _{MAX}	Max. Attenuation		-83	-79.5	-75	dB
A _{STEP}	Step Resolution		0	0.5	1	dB
E _A	Attenuation Set Error	G = -20 to +20dB	-0.75	0	+0.75	dB
		G = -80 to -20dB	-4	0	3	dB
E _T	Tracking Error				2	dB
V _{DC}	DC Steps	Adjacent Attenuation Steps		0.1	3	mV
		From 0dB to G _{MIN}		0.5	5	mV

SOFT MUTE

A _{MUTE}	Mute Attenuation		80	100		dB
T _D	Delay Time	T1		0.48	1	ms
		T2		0.96	2	ms
		T3	70	123	170	ms
		T4	200	324	600	ms
V _{TH low}	Low Threshold for SM-Pin ³⁾				1	V
V _{TH high}	High Threshold for SM - Pin		2.5			V
R _{PU}	Internal pull-up resistor		32	45	58	kΩ
V _{PU}	Internal pull-up Voltage			3.3		V

3. The SM-Pin is active low (Mute = 0)

BASS CONTROL

C _{RANGE}	Control Range		±14	±15.5	±16	dB
A _{STEP}	Step Resolution		0.5	1	1.5	dB

Table 1. ELECTRICAL CHARACTERISTICS (continued)(V_S=9V; T_{amb}=25°C; R_L=10kΩ; all gains=0dB; f=1kHz; unless otherwise specified)

Symbol	Parameter	Test Condition	Min.	Typ.	Max.	Unit
f _C	Center Frequency	f _{C1}	54	60	66	Hz
		f _{C2}	63	70	77	Hz
		f _{C3}	72	80	88	Hz
		f _{C4}	81	90	99	Hz
		f _{C5}	90	100	110	Hz
		f _{C6}	117	130	143	Hz
		f _{C7}	135	150	165	Hz
		f _{C8}	180	200	220	Hz
Q _{BASS}	Quality Factor	Q ₁	0.9	1	1.1	
		Q ₂	1.1	1.25	1.4	
		Q ₃	1.3	1.5	1.7	
		Q ₄	1.8	2	2.2	
DC _{GAIN}	Bass-DC-Gain	DC = off	-1	0	+1	dB
		DC = on	4	4.4	6	dB

TREBLE CONTROL

C _{RANGE}	Control Range		±14	±15	±16	dB
A _{STEP}	Step Resolution		0.5	1	1.5	dB
f _C	Center Frequency	f _{C1}	8	10	12	kHz
		f _{C2}	10	12.5	15	kHz
		f _{C3}	12	15	18	kHz
		f _{C4}	14	17.5	21	kHz

PAUSE DETECTOR⁴⁾

V _{TH}	Zero Crossing Threshold	Window 1		40		mV
		Window 2		80		mV
		Window 3		160		mV
I _{DELAY}	Pull-Up Current		15	25	35	μA
V _{THP}	Pause Threshold			3.0		V

4. If configured as Pause-Output

SPEAKER ATTENUATORS

R _{in}	Input Impedance		35	50	65	kΩ
G _{MAX}	Max. Gain		14	15	16	dB
A _{MAX}	Max. Attenuation		-83	-79	-75	dB
A _{STEP}	Step Resolution		0.5	1	1.5	dB
A _{MUTE}	Output Mute Attenuation		80	90		dB
E _E	Attenuation Set Error				2	dB
V _{DC}	DC Steps	Adjacent Attenuation Steps		0.1	5	mV

Table 1. ELECTRICAL CHARACTERISTICS (continued)

(V_S=9V; T_{amb}=25°C; R_L=10kΩ; all gains=0dB; f=1kHz; unless otherwise specified)

Symbol	Parameter	Test Condition	Min.	Typ.	Max.	Unit
MONO VOICE BANDPASS						
f _{HP}	Highpass corner frequency	f _{HP1}	81	90	99	Hz
		f _{HP2}	120	135	150	Hz
		f _{HP3}	162	180	198	Hz
		f _{HP4}	193	215	237	Hz
		f _{HP5}	270	300	330	Hz
		f _{HP6}	405	450	495	Hz
		f _{HP7}	540	600	660	Hz
		f _{HP8}	675	750	825	Hz
f _{LP}	Lowpass corner frequency	f _{LP1}	2.7	3	3.3	kHz
		f _{LP2}	5.4	6	6.6	kHz

COMPANDER

G _{MAX}	max. Compander Gain	Vi < -46dB		19		dB
		Vi < -46dB, Anti-Clip=On		29		dB
t _{Att}	Attack time	t _{Att1}		6		ms
		t _{Att2}		12		ms
		t _{Att3}		24		ms
		t _{Att4}		49		ms
t _{Rel}	Release time	t _{Rel1}		390		ms
		t _{Rel2}		780		ms
		t _{Rel3}		1.17		s
		t _{Rel4}		1.56		s
V _{REF}	Compander Reference Input-Level (equals 0dB)	V _{REF1}		0.5		V _{RMS}
		V _{REF2}		1.0		V _{RMS}
		V _{REF3}		2.0		V _{RMS}
C _F	Compression Factor	Output Signal / Input Signal		0.5		

AUDIO OUTPUTS

V _{CLIP}	Clipping Level	d = 0.3%	2.2	2.6		V _{RMS}
R _L	Output Load Resistance		2			kΩ
C _L	Output Load Capacitance				10	nF
R _{OUT}	Output Impedance			30	120	Ω
V _{DC}	DC Voltage Level		4.3	4.5	4.7	V

GENERAL

e _{NO}	Output Noise	BW = 20Hz - 20kHz;output muted		3	15	μV
		BW = 20Hz - 20kHz all gains = 0dB single ended inputs		10	20	μV

Table 1. ELECTRICAL CHARACTERISTICS (continued)(V_S=9V; T_{amb}=25°C; R_L=10kΩ; all gains=0dB; f=1kHz; unless otherwise specified)

Symbol	Parameter	Test Condition	Min.	Typ.	Max.	Unit
S/N	Signal to Noise Ratio	all gains = 0dB flat; V _O = 2V _{RMS}		106		dB
		bass, treble at +12dB; a-weighted; V _O = 2.6V _{RMS}		100		dB
d	distortion	V _{IN} = 1V _{RMS} ; all stages 0dB		0.005	0.1	%
		V _{OUT} = 1V _{RMS} ; Bass & Treble = 12dB		0.05	0.1	%
S _C	Channel Separation left/right		80	100		dB
E _T	Total Tracking Error	A _V = 0 to -20dB	-1	0	1	dB
		A _V = -20 to -60dB	-2	0	2	dB

2 DESCRIPTION OF THE AUDIOPROCESSOR PART

2.1 Input stages

In the basic configuration two full-differential, two mono-differential, one single ended stereo and one single-ended mono input are available. In addition a dedicated input for the stereodecoder MPX-signal is present.

Figure 1. Input stages

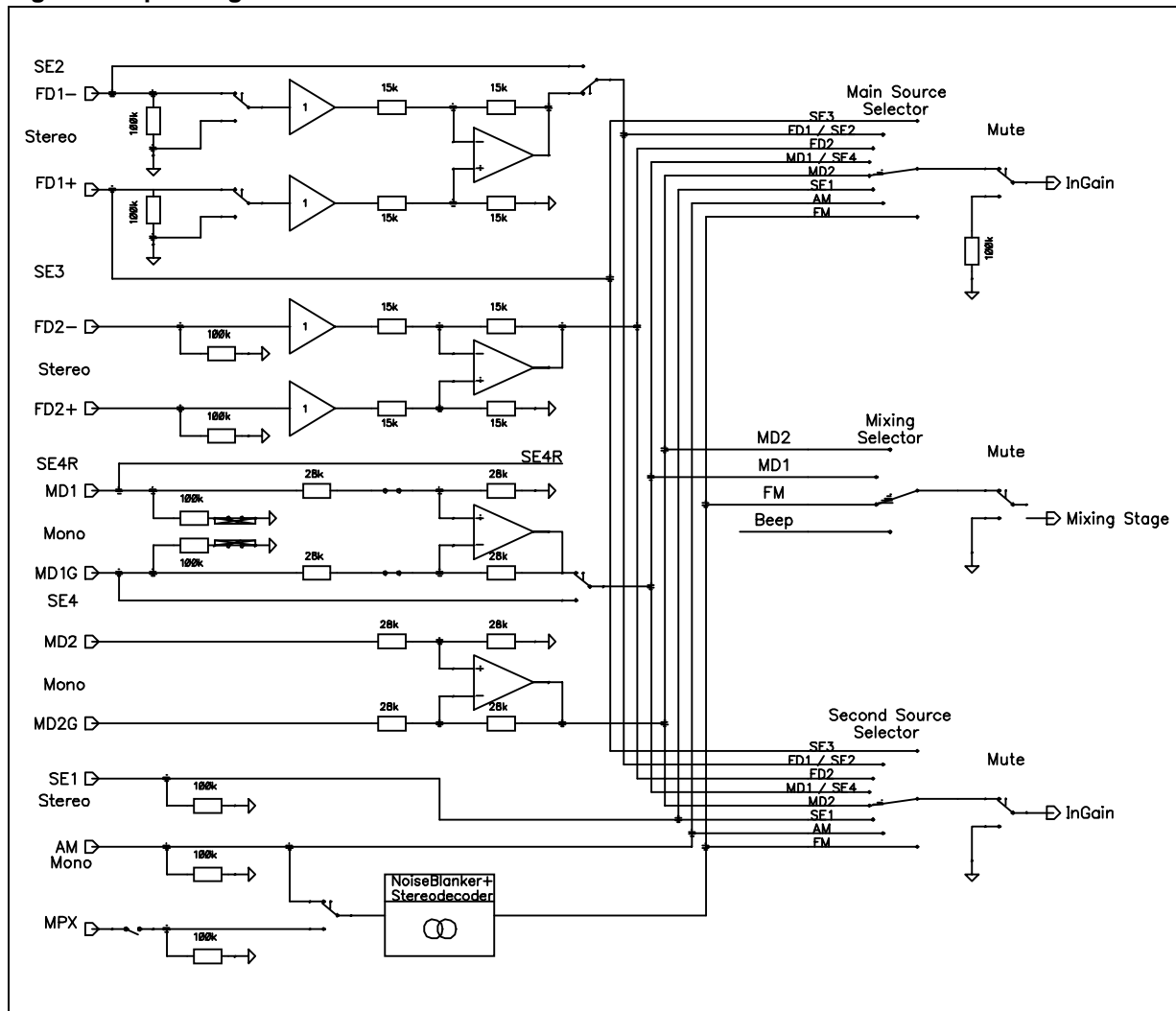

2.1.1 Full-differential stereo Input 1 (FD1)

The FD1-input is implemented as a buffered full-differential stereo stage with 100kΩ input-impedance at each input. The attenuation is programmable in 3 steps from 0 to -12dB in order to adapt the incoming signal level. A 6dB attenuation is included in the differential stage, the additional 6dB are done by a following resistive divider. This input is also configurable as two single-ended stereo inputs (see pin-out).

2.1.2 Full-differential stereo Input 2 (FD2)

The FD2-input has the same general structure as FD1, but with a programmable attenuation of 0 or 6dB embedded in the differential stage.

2.1.3 Mono-differential Input 1 (MD1)

The MD1-input is designed as a basic differential stage with 56k Ω input-impedance. This input is configurable as a single-ended stereo input (see pin-out).

2.1.4 Mono-differential Input 2 (MD2)

The MD2-input has the same topology as MD1, but without the possibility to configure it to single ended.

2.1.5 Single-ended stereo Input (SE1), single-ended mono input (AM) and FM-MPX input

All single ended inputs offer an input impedance of 100k Ω . The AM-pin can be connected by software to the input of the stereodecoder in order to use the AM-Noiseblanker and AM-High-Cut feature.

2.2 AutoZero

The AutoZero allows a reduction of the number of pins as well as external components by canceling any offset generated by or before the In-Gain-stage (Please notice that externally generated offsets, e.g. generated through the leakage current of the coupling capacitors, are not canceled).

The auto-zeroing is started every time the DATA-BYTE 0 is selected and needs max. 0.3ms for the alignment. To avoid audible clicks the Audioprocessor is muted before the loudness stage during this time. The AutoZero-feature is only present in the main signal-path.

2.2.1 AutoZero for Stereodecoder-Selection

A special procedure is recommended for selecting the stereodecoder at the main input-selector to guarantee an optimum offset-cancellation:

(Step 0: SoftMute or Mute the signal-path)

Step 1: Temporary deselect the stereodecoder at all input-selectors

Step 2: Configure the stereodecoder via IIC-Bus

Step 3: Wait 1ms

Step 4: Select the stereodecoder at the main input-selector first

The root cause of this procedure is, that after muting the stereodecoder (Step 1), the internal stereodecoder filters have to settle in order to perform a proper offset-cancellation.

2.2.2 AutoZero-Remain

In some cases, for example if the μ P is executing a refresh cycle of the IIC-Bus-programming, it is not useful to start a new AutoZero-action because no new source is selected and an undesired mute would appear at the outputs. For such applications the A631 could be switched in the AutoZero-Remain-Mode (Bit 6 of the subaddress-byte). If this bit is set to high, the DATABYTE 0 could be loaded without invoking the AutoZero and the old adjustment-value remains.

2.3 Pause Detector / MUX-Output

The pin number 40(Pause/MUX) is configurable for two different functions:

1. During Pause-Detector OFF this pin is used as a mono-output of the main input-selector. This signal is often used to drive a level-/equalizer-display on the carradio front-panel.
2. During Pause-Detector ON the pin is used to define the time-constant of the detector by an external capacitor.

The pause-detector is driven by the internal stereodecoder-outputs in order to use pauses in the FM-signal for alternate-frequency-jumps. If the signal-level of both stereodecoder channels is outside the programmed voltage-window, the external capacitor is abruptly discharged. Inside the pause-condition the capacitor is slowly recharged by a constant current of 25 μ A. The pause information is also available via IIC-Bus (see IIC-Bus programming).

2.4 Loudness

There are four parameters programmable in the loudness stage:

2.4.1 Attenuation

Figure 2 shows the attenuation as a function of frequency at $f_P = 400\text{Hz}$.

Figure 2. Loudness Attenuation @ $f_P = 400\text{Hz}$

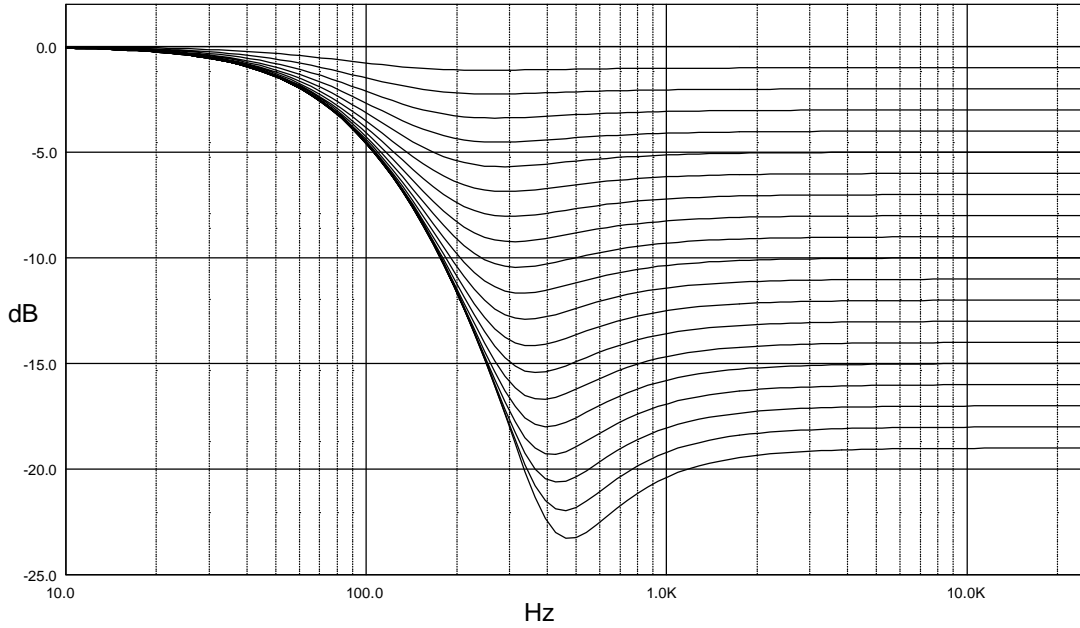

2.4.2 Peak Frequency

Figure 3 shows the four possible peak-frequencies at 200, 400, 600 and 800Hz

Figure 3. Loudness Center frequencies @ Attn. = 15dB

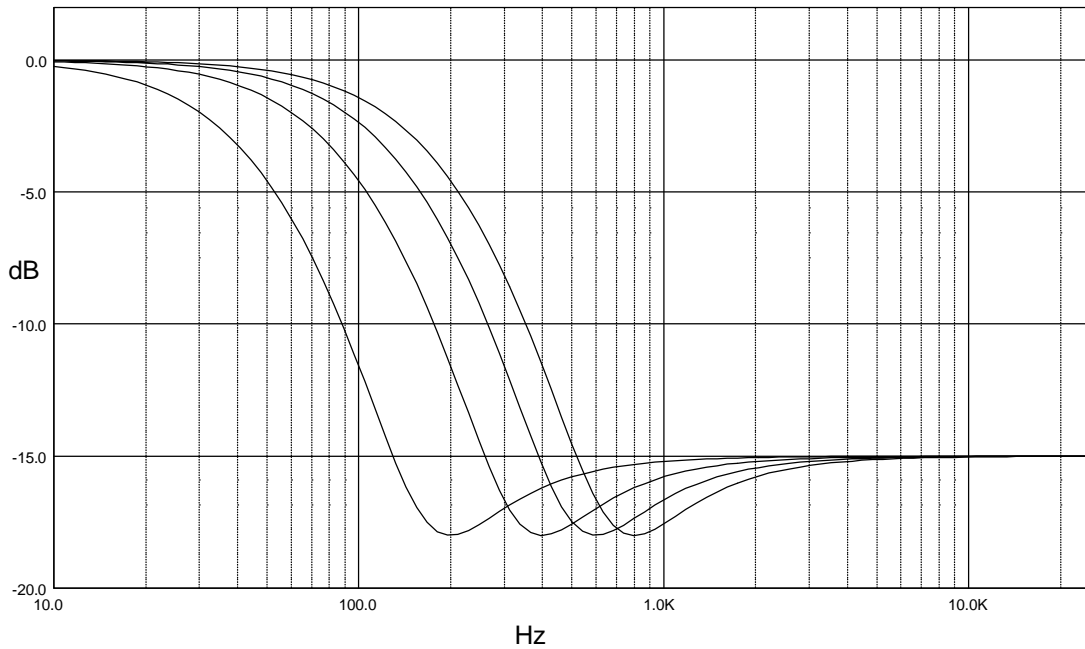

2.4.3 Loudness Order

Different shapes of 1st and 2nd-Order Loudness

Figure 4. 1st and 2nd Order Loudness @ Attn. = 15dB, fP=400Hz

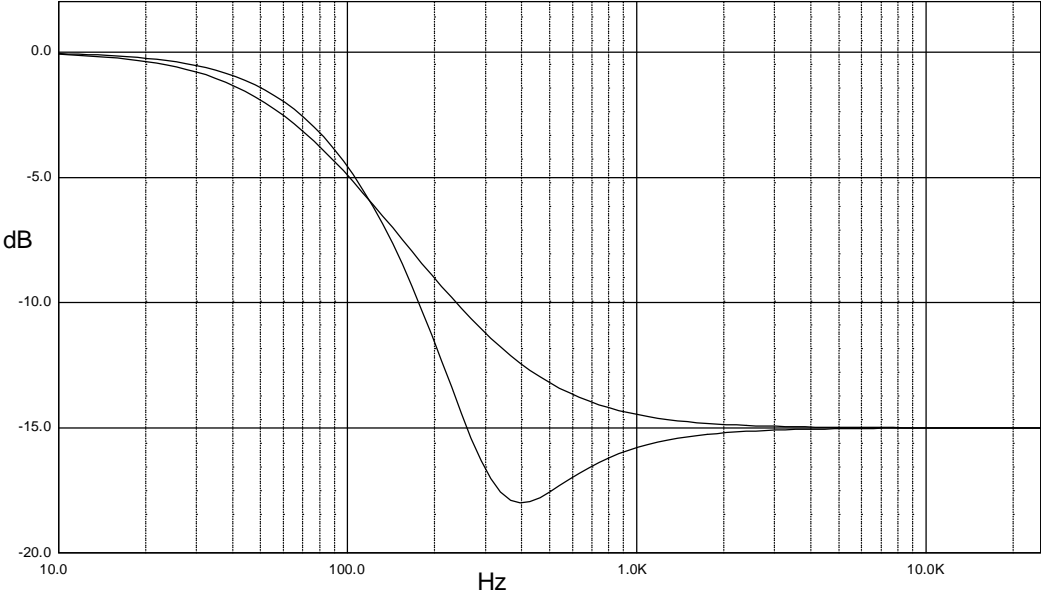

2.4.4 Flat Mode

In flat mode the loudness stage works as a 0dB to -19dB attenuator.

2.5 SoftMute

The digitally controlled SoftMute stage allows muting/demuting the signal with a I2C-bus programmable slope. The mute process can either be activated by the SoftMute pin or by the I2C-bus. This slope is realized in a special S-shaped curve to mute slow in the critical regions (see Figure 5). For timing purposes the Bit of the I2C-bus output register is set to 1 from the start of muting until the end of de-muting.

Figure 5. Softmute-Timing

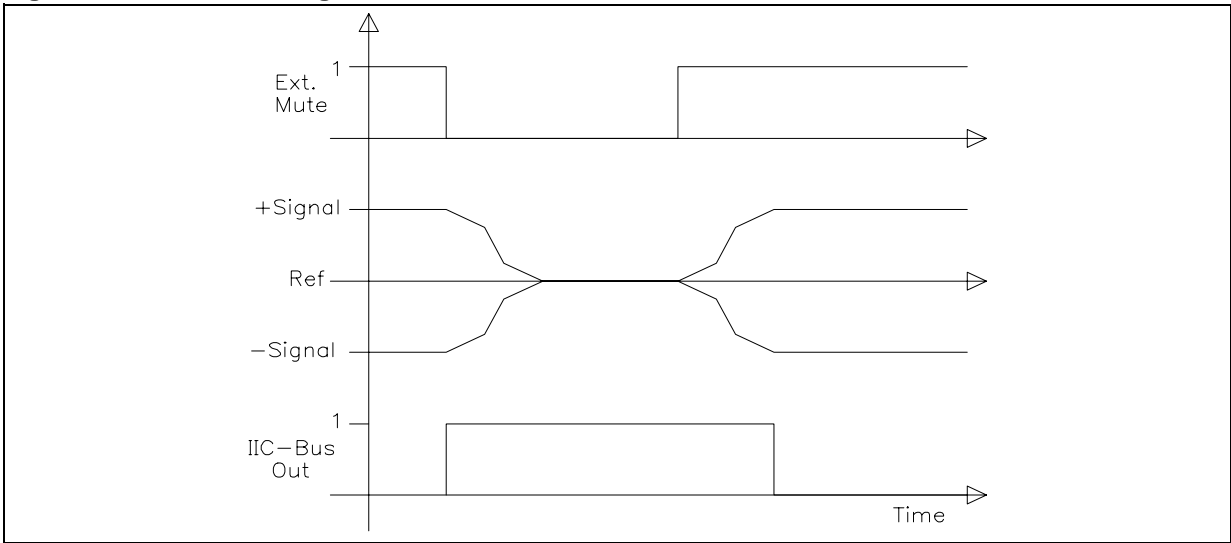

Note: Please notice that a started Mute-action is always terminated and could not be interrupted by a change of the mute -signal.

2.6 SoftStep-Volume

When the volume-level is changed audible clicks could appear at the output. The root cause of those clicks could either be a DC-Offset before the volume-stage or the sudden change of the envelope of the audiosignal. With the SoftStep-feature both kinds of clicks could be reduced to a minimum and are no more audible. The blend-time from one step to the next is programmable in four steps.

Figure 6. SoftStep-Timing

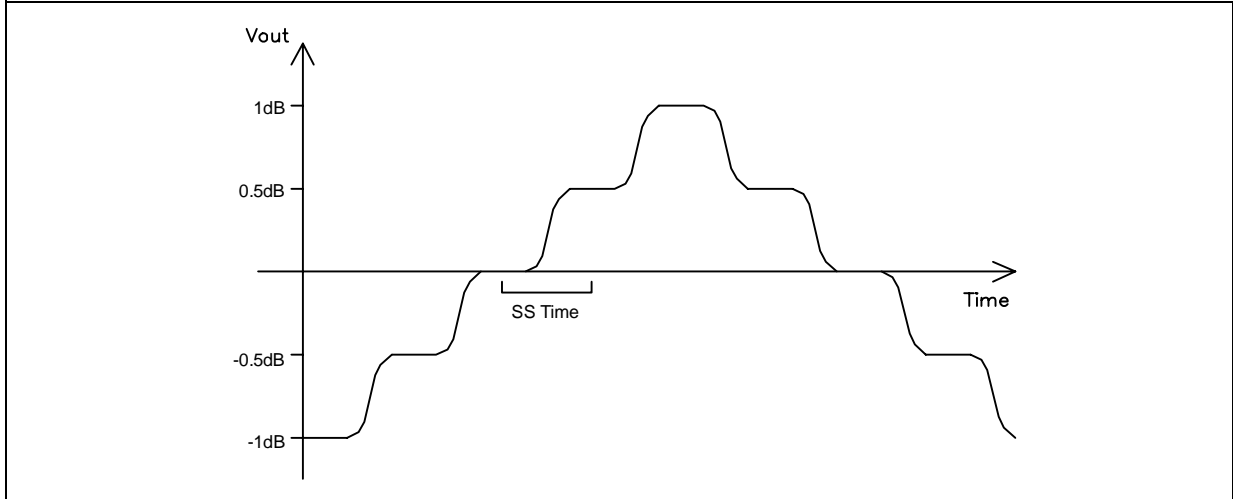

Note: For steps more than 0.5dB the SoftStep mode should be deactivated because it could generate a hard 1dB step during the blend-time

2.7 Bass

There are four parameters programmable in the bass stage:

2.7.1 Attenuation

Figure 7 shows the attenuation as a function of frequency at a center frequency of 80Hz.

Figure 7. Bass Control @ fC = 80Hz, Q = 1

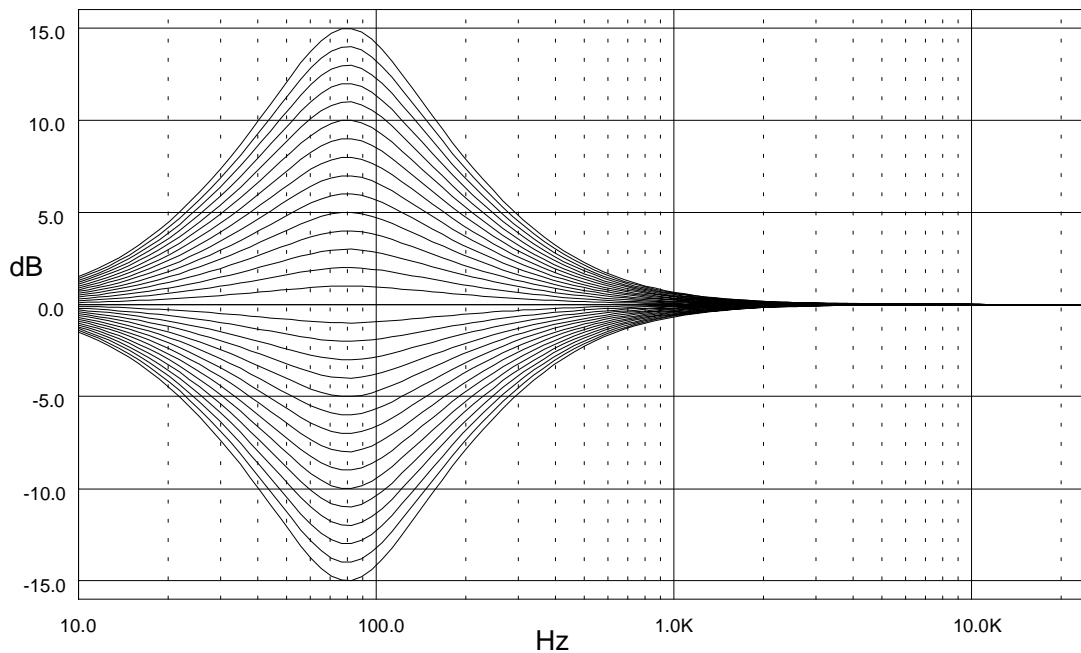

2.7.2 Center Frequency

Figure 8 shows the eight possible center frequencies 60, 70, 80, 90, 100, 130, 150 and 200Hz.

Figure 8. Bass center Frequencies @ Gain = 14dB, Q = 1

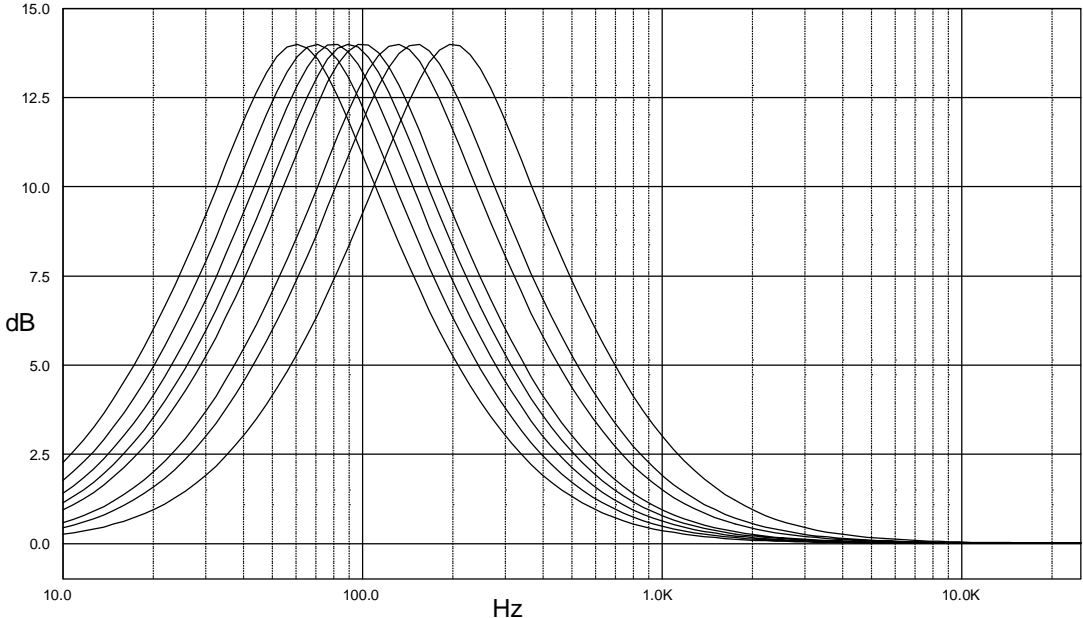

2.7.3 Quality Factors

Figure 9 shows the four possible quality factors 1, 1.25, 1.5 and 2.

Figure 9. Bass Quality factors @ Gain = 14dB, fC = 80Hz

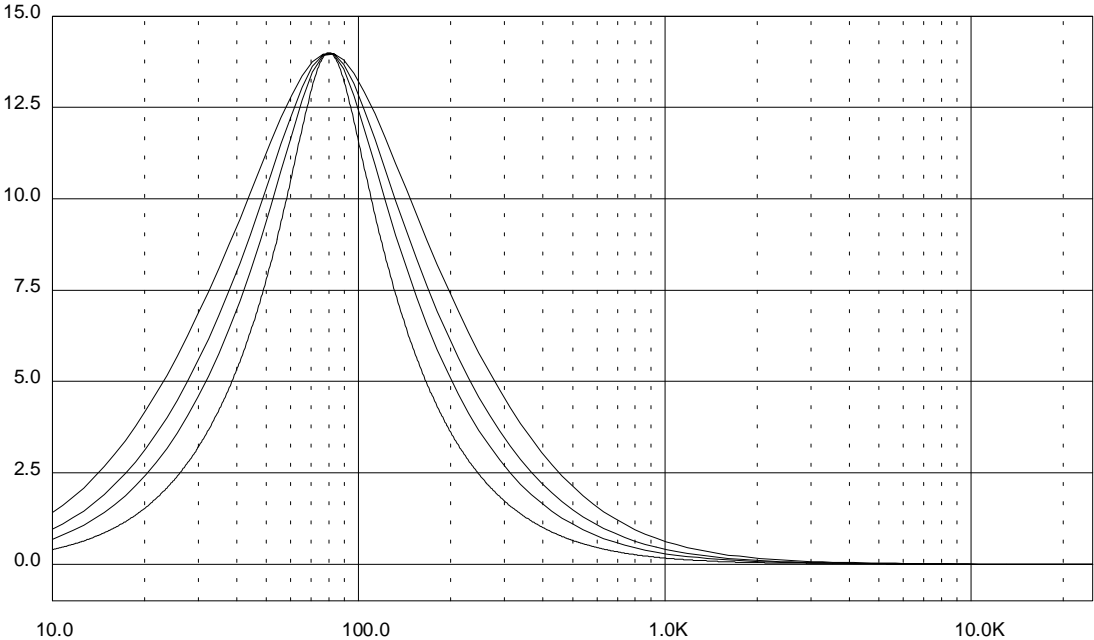

2.7.4 DC Mode

In this mode the DC-gain is increased by 4.4dB. In addition the programmed center frequency and quality factor is decreased by 25% which can be used to reach alternative center frequencies or quality factors.

Figure 10. Bass normal and DC Mode @ Gain = 14dB, fC = 80Hz

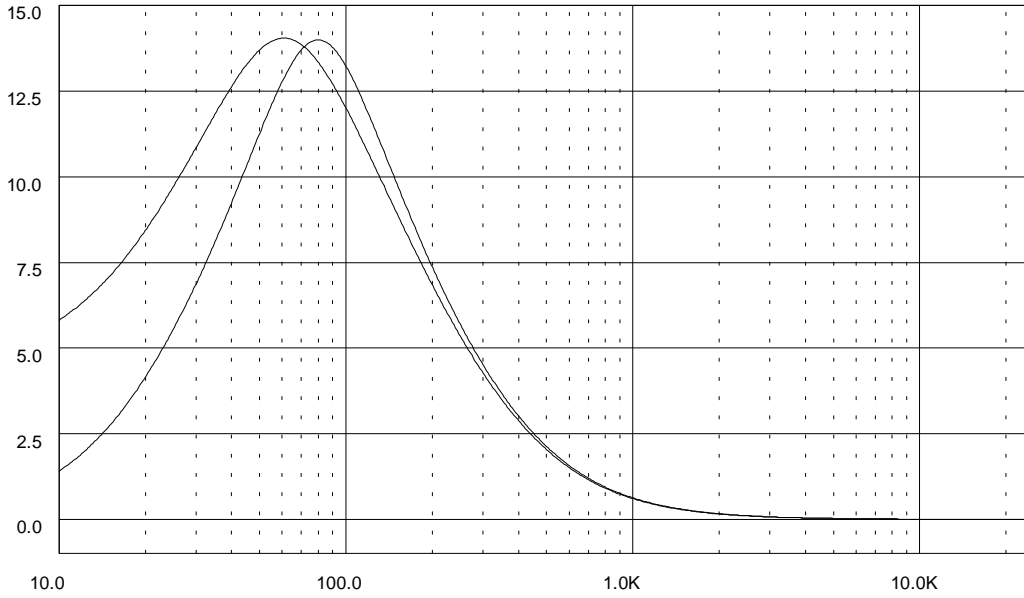

Note: The center frequency, Q and DC-mode can be set fully independently.

2.8 Treble

There are two parameters programmable in the treble stage:

2.8.1 Attenuation

Figure 11 shows the attenuation as a function of frequency at a center frequency of 17.5kHz.

Figure 11. Treble Control @ fC = 17.5kHz

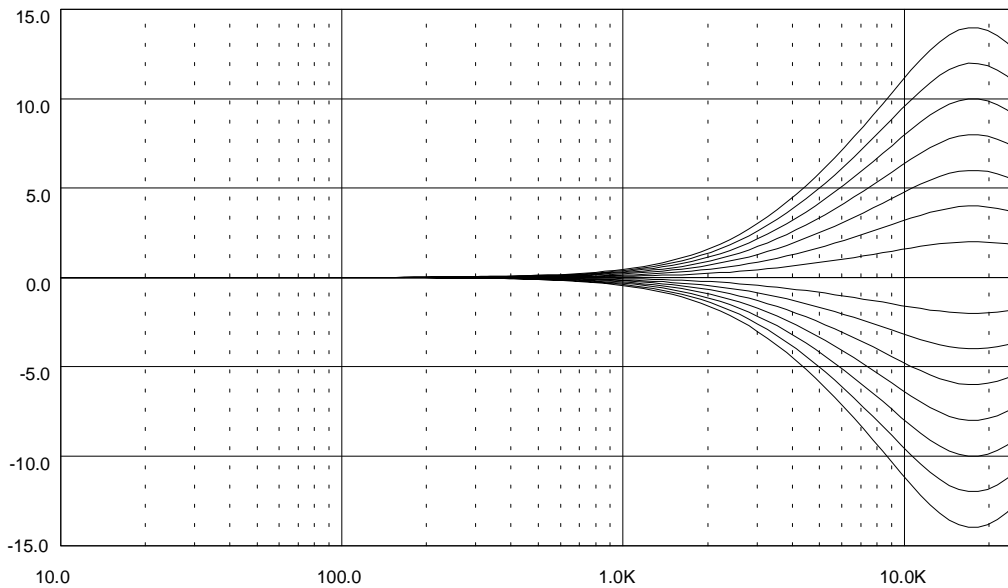

2.8.2 Center Frequency

Figure 12 shows the four possible center frequencies 10k, 12.5k, 15k and 17.5kHz.

Figure 12. Treble Center Frequencies @ Gain = 14dB

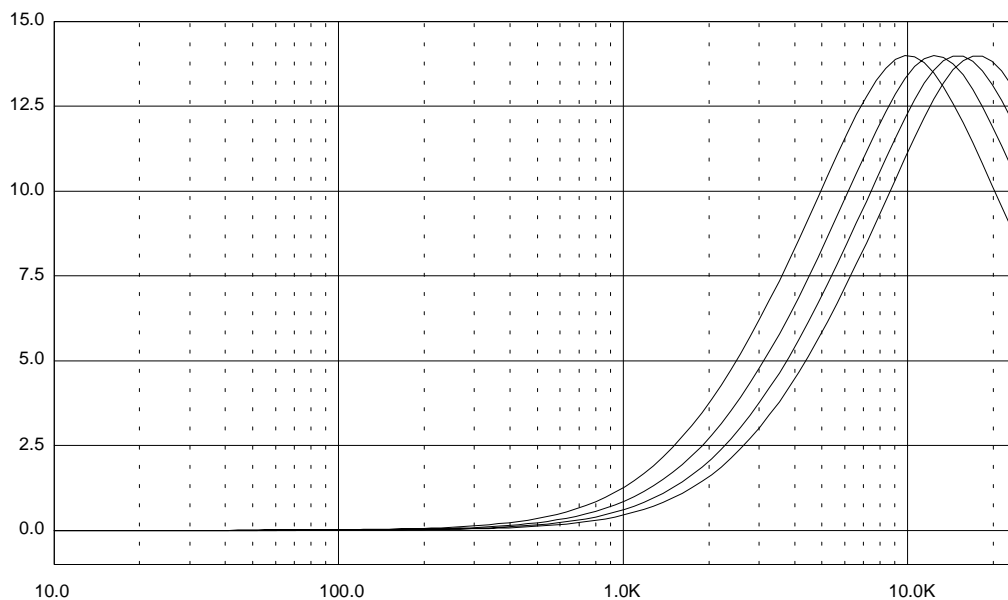

2.9 EQ-Filter

There are two EQ-Filters present in the A631: one for the High-Frequency-Range and one for the Low-Frequency-Range with a certain overlap. They are programmable in center-frequency (4 frequencies/octave), in Q(4 settings) and in Attenuation (1dB-steps). In addition several configurations are possible to use the filters in the front- or rear-path.

Table 2. Gain, Center Frequency and Quality Factor of Equalizer Filters

Parameter	Min	Max	Unit
Gain	-15	15	dB
Center Frequency Filter 1	63	840	Hz
Center Frequency Filter 2	300	4000	Hz
Quality Factor	1	4	

2.9.1 Equalizer-Setup

The two Filters can be configured in multiple ways in order to cover as most as possible applications. Both filters can be programmed to be either in the front- or in the rear-path, respectively. This feature enables to have e.g. the High-Filter in the front- and both filters in the rear-path.

Figure 13. Equalizer Configuration

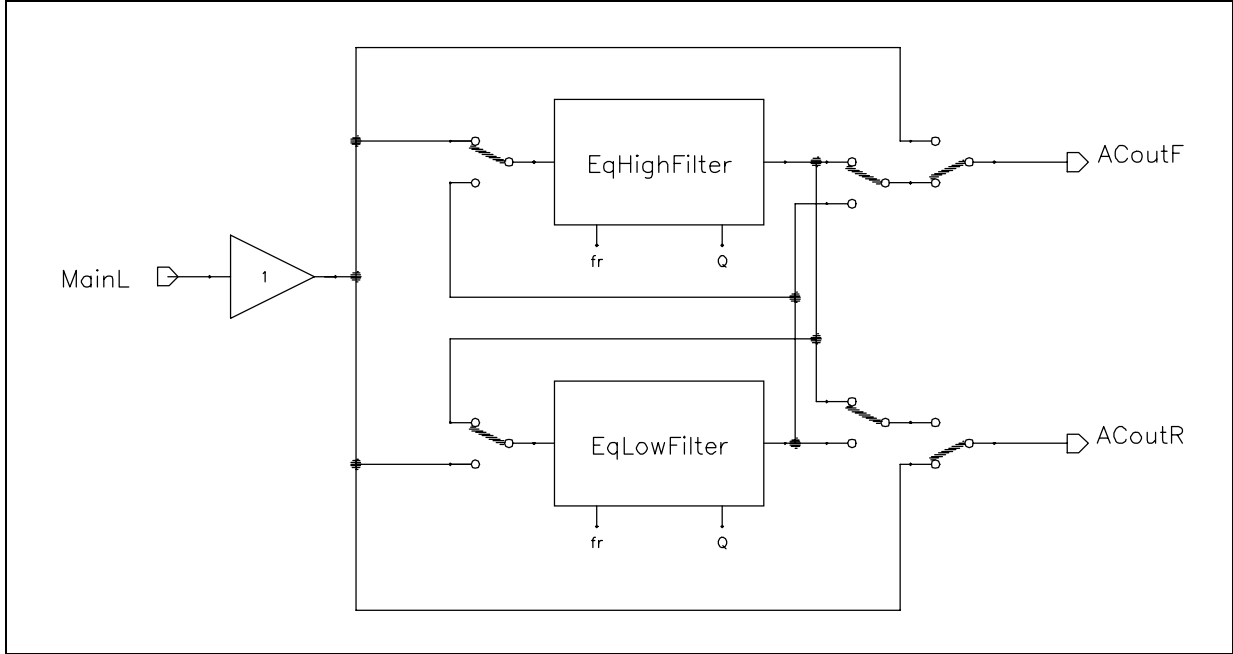

2.9.2 Attenuation

Figure 14 shows the attenuation as a function of frequency at a center frequency of 625 Hz.

Figure 14. Gain/Attenuation of EQ-Filter

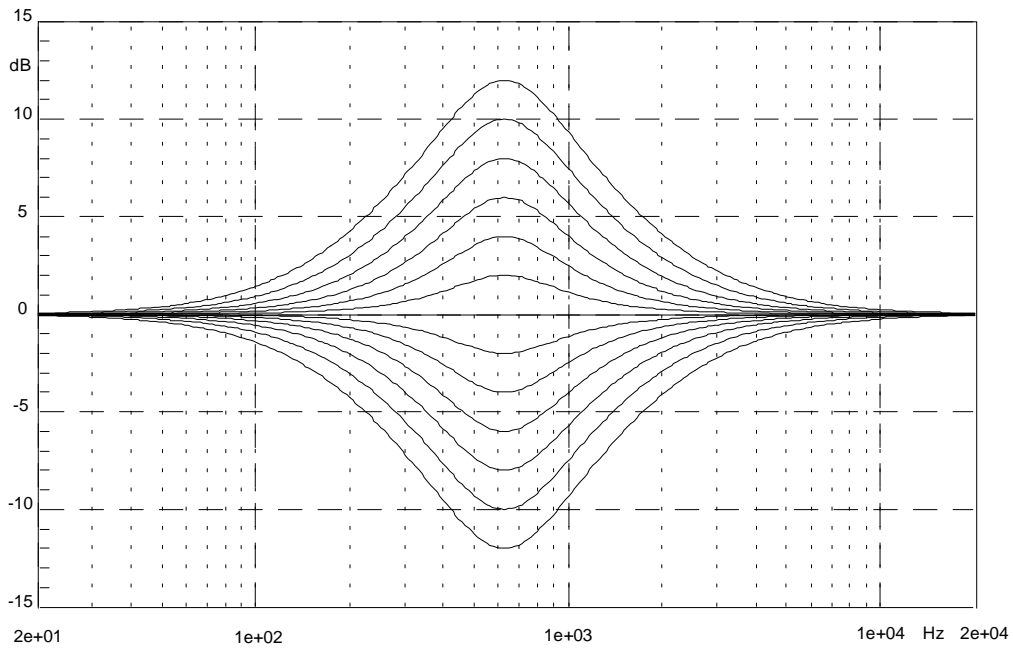

2.9.3 Frequencies

Figure 15 shows the different center frequencies of the EQ-Filter at 12 dB gain

Figure 15. Center-Frequencies of EQ-Filter

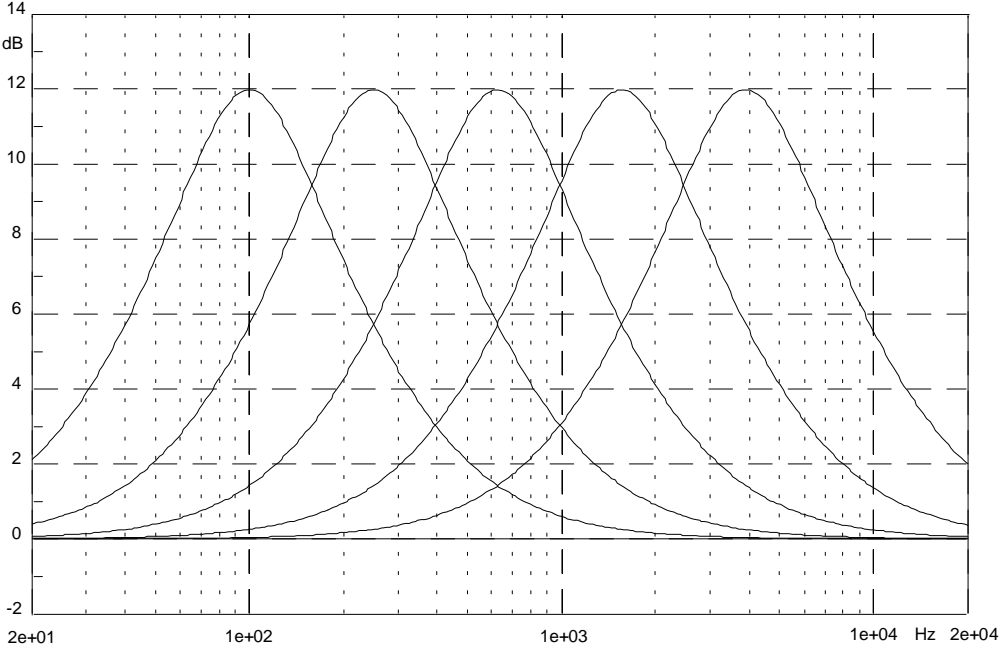

2.9.4 Q-Factor

Figure 16 shows the four possible quality factors 1, 2, 3 and 4.

Figure 16. Different Q-factors of Equalizer-Filter

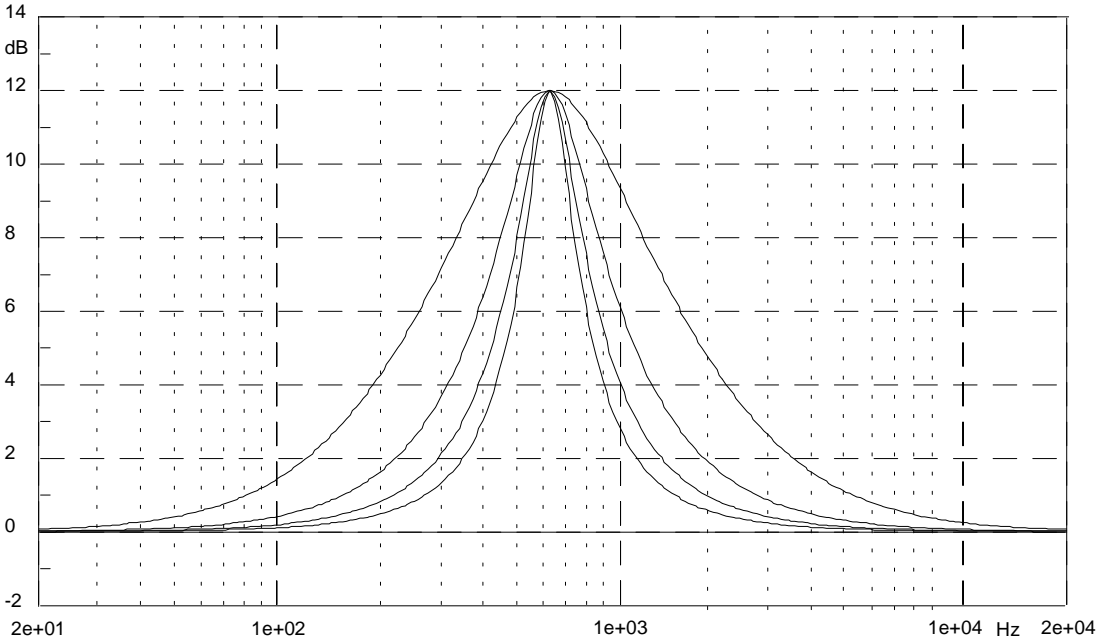

2.10 Comander

2.10.1 Signal-Compression

A fully integrated signal-compressor with programmable Attack- and Decay-times is present in the A631 (see Figure 17). The compander consists of a signal-level detection, an A/D-Converter plus adder and the normal SoftStep-Volume-stage. First of all the left and the right InGain-signal is rectified, respectively, and the logarithm is build from the summed signal. The following low-pass smooth the output-signal of the logarithm-amplifier and improves the low-frequency suppression. The low-pass output-voltage then is A/D-converted and added to the current volume-word defined by the IIC-Bus. Assuming reference-level or higher at the compander input, the output of the ADC is 0. At lower levels the voltage is increasing with 1 Bit/dB. It is obvious that with this configuration and a 0.5dB-step volume-stage the compression rate is fixed to 2:1 (1dB less at the input leads to 0.5dB less at the output). The internal reference-level of the compander is programmable in three steps from 0.5V_{RMS} to 2V_{RMS}. For a proper behavior of the compression-circuit it is mandatory to have at a 0dB input-signal exactly the programmed reference-level after the InGain-stage. E.g. at a configured reference-level of 0.5V_{RMS} the output of the InGain-stage has to have also 0.5V_{RMS} at 0dB source-signal (Usually the 0dB for CD is defined as the maximum possible signal-level). To adapt the external level to the internal reference-level the programmable attenuation in the differential-stages and the InGain can be used.

Figure 17. Comander Block Diagram

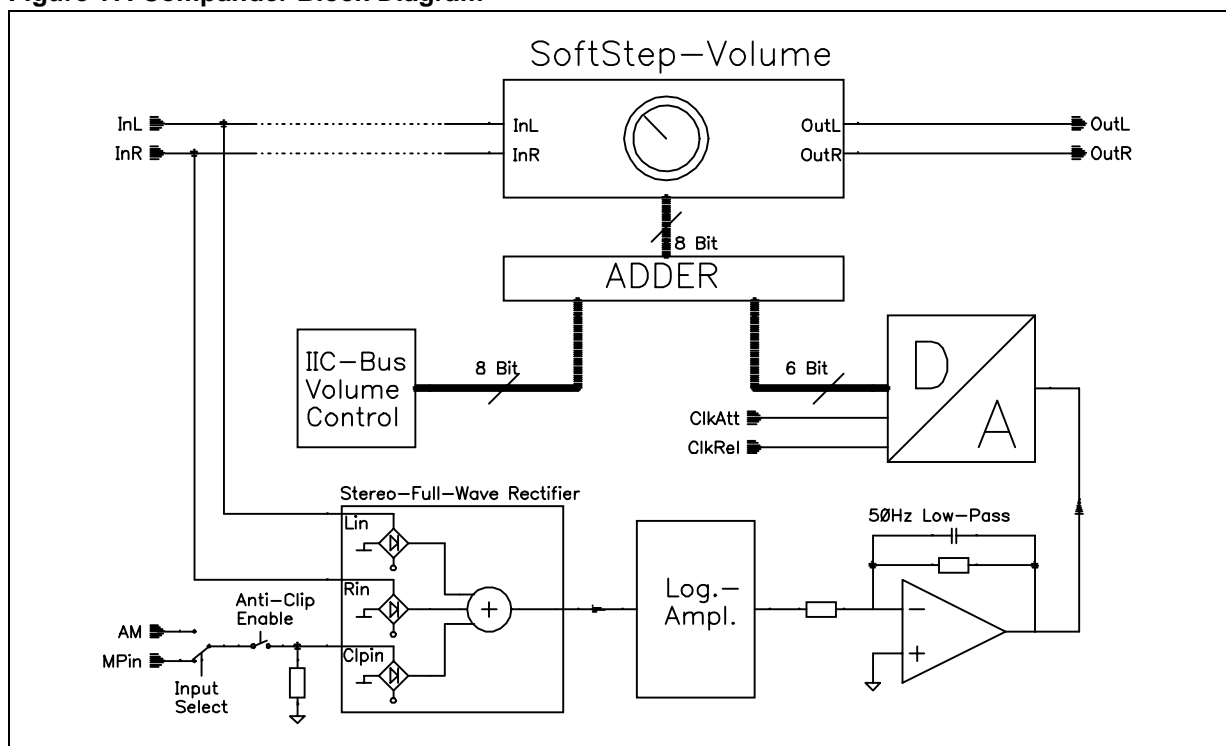

2.10.2 Anti-Clipping

In a second application the compander-circuit can be used for a Anti-Clipping or Limiting function. In this case one of the dedicated inputs (AM or MPin) is connected directly to the Clip-Detector of the Power-Amplifier. If no clipping is detected, the open-collector output of the Power-Amplifier is highohmic and the input-voltage of the rectifier is V_{REF}. The level-detector interprets this as a very small signal and reacts with the maximum programmed compander-gain. In the application this gain has to be compensated by decreasing the volume with the same value in order to get the desired output-level. In clipping situation the open-collector-current generates a voltage-drop at the rectifier-input, which forces the compander to decrease the gain until the clipping disappears.

It is even possible to run the compression-mode and the Anti-Clipping mode in parallel. In this case the maximum compander-Gain should be set to 29 dB.

2.10.3 Characteristic

To achieve the desired compression characteristic like shown below the volume has to be decreased by 4dB.

Figure 18. Compander Characteristic

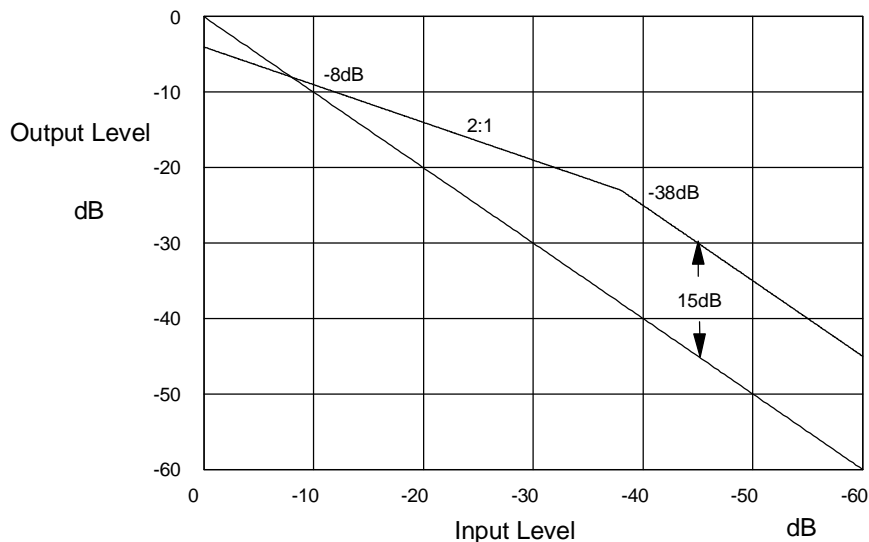

2.10.4 I²C -BUS-Timing

When the Compander is active a volume- word coming from this stage is added to the I²C-Bus volume-word and the volume is changed with a soft slope between adjacent steps (SoftStep-stage). As mentioned in the description of this stage it is not recommended to change the volume during this slope. To avoid this behaviour while the Compander is working, and the volume has to be changed, the compander-hold-bit is implemented (Bit 7 in the subaddress-byte). The recommended timing for changing the volume during compander-ON is the following:

1. Set the compander-hold-bit
2. Wait the actual SoftStep-time
3. Change the volume
4. Reset the compander-hold-bit

The SoftStep-times are in compander-ON condition automatically adapted to the attack-time of the Compander. In the following table the related SoftStep-times are shown:

Attack-Time	SoftStep-Time
6ms	0.16ms
12ms	0.32ms
24ms	0.64ms
48ms	1.28ms

2.10.5 AC-Coupling

In some applications additional signal manipulations are desired, for example surround-sound or more-band-equalizing. For this purpose an AC-Coupling is placed before the speaker-attenuators, which can be activated or internally shorted by I²C-Bus. In short condition the input-signal of the speaker-attenuator is available at the AC-Outputs. The input-impedance of this AC-Inputs is 50k Ω .

2.10.6 Output Selector

The output-selector allows to connect the main- or the second-source to the Front-, Rear-speaker-attenuator, respectively. As an example of this programming the device is able to connect via software the main-source to the back (rear) and the second-source to the front (see Figure 19).

Figure 19. Output Selector

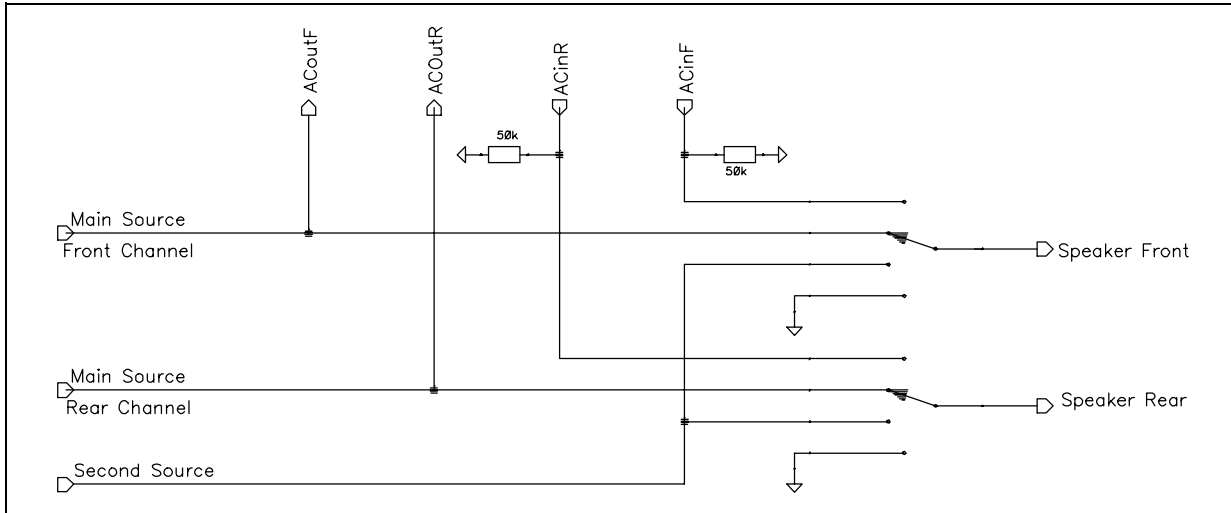

2.10.7 Speaker-Attenuator and Mixing

A Mixing-stage is placed after each speaker-attenuator and can be set independently to mixing-mode. Having a full volume for the Mix-signal the stage offers a wide flexibility to adapt the mixing levels.

Figure 20. Mixing Configuration

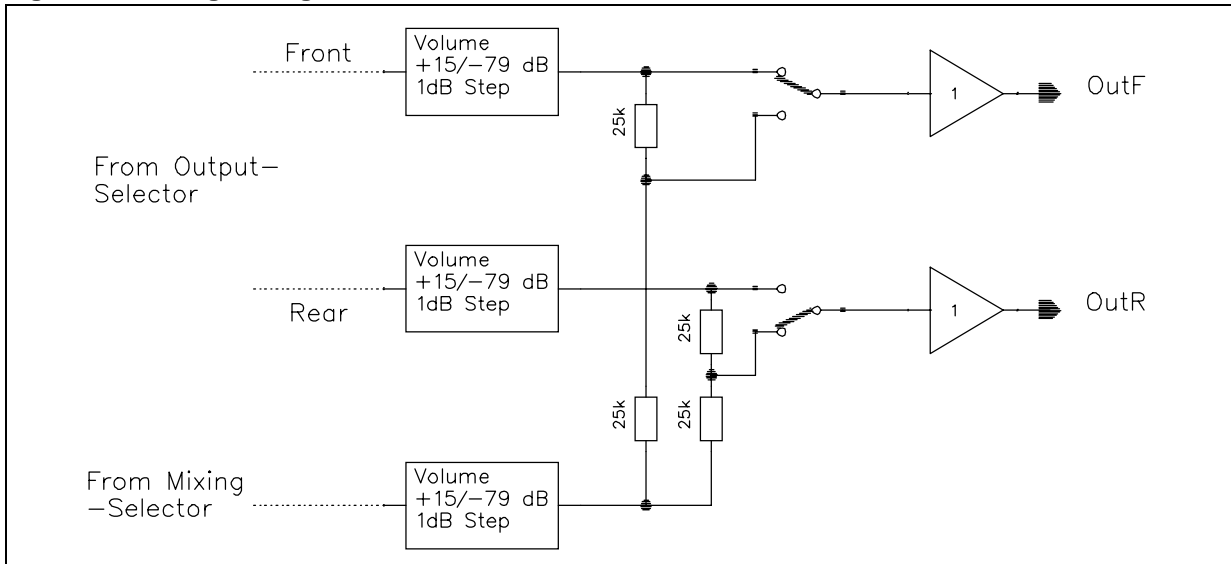

2.10.8 Audioprocessor Testing

During the Testmode, which can be activated by setting bit D₀ of the stereodecoder testing-byte and the audioprocessor testing byte, several internal signals are available at the FD2R- pin. During this mode the input resistance of 100kOhm is disconnected from the pin. The internal signals available are shown in the Data-byte specification.

3 STERODECODER-PART

3.1 Features:

- no external components necessary
- PLL with adjustment free, fully integrated VCO
- automatic pilot dependent MONO/STEREO switching
- very high suppression of intermodulation and interference
- programmable Roll-Off compensation
- dedicated RDS-Softmute
- Highcut- and Stereoblend-characteristics programmable in a wide range
- FM/AMNoiseblanker with several threshold controls
- Multipath-detector with programmable internal/external influence
- I²C-bus control of all necessary functions

Table 3. ELECTRICAL CHARACTERISTICS

$V_S = 9V$, deemphasis time constant = $50\mu s$, MPX input voltage $V_{MPX} = 500mV$ (75kHz deviation), modulation frequency = 1kHz, input gain = 6dB, $T_{amb} = 27^\circ C$, unless otherwise specified.

Symbol	Parameter	Test Conditions	Min.	Typ.	Max.	Unit
V_{in}	MPX Input Level	Input Gain = 3.5dB		0.5	1.25	V_{rms}
R_{in}	Input Resistance		70	100	130	$k\Omega$
G_{min}	Min. Input Gain		1.5	3.5	4.5	dB
G_{max}	Max. Input Gain		8.5	11	12.5	dB
G_{step}	Step Resolution		1.75	2.5	3.25	dB
SVRR	Supply Voltage Ripple Rejection	$V_{ripple} = 100mV$, $f = 1kHz$		55		dB
α	Max. Channel Separation		30	50		dB
THD	Total Harmonic Distortion	$f_{in}=1kHz$, mono		0.02	0.3	%
$\frac{S+N}{N}$	Signal plus Noise to Noise Ratio	A-weighted, $S = 2V_{rms}$	80	91		dB

MONO/STEREO-SWITCH

V_{PTHST1}	Pilot Threshold Voltage	for Stereo, PTH = 1	10	15	25	mV
V_{PTHST0}	Pilot Threshold Voltage	for Stereo, PTH = 0	15	25	35	mV
V_{PTHMO1}	Pilot Threshold Voltage	for Mono, PTH = 1	7	12	17	mV
V_{PTHMO0}	Pilot Threshold Voltage	for Mono, PTH = 0	10	19	25	mV
PLL						
$\Delta f/f$	Capture Range		0.5			%

Table 3. ELECTRICAL CHARACTERISTICS (continued)

$V_S = 9V$, deemphasis time constant = $50\mu s$, MPX input voltage $V_{MPX} = 500mV$ (75kHz deviation), modulation frequency = 1kHz, input gain = 6dB, $T_{amb} = 27^\circ C$, unless otherwise specified.

Symbol	Parameter	Test Conditions	Min.	Typ.	Max.	Unit
DEEMPHASIS and HIGHCUT						
$\tau_{DeempFM}$	Deemphasis Timeconstants FM	$V_{LEVEL} \gg V_{HCH}$	25	50	75	μs
		$V_{LEVEL} \gg V_{HCH}$	44	62.5	80	μs
		$V_{LEVEL} \gg V_{HCH}$	50	75	100	μs
		$V_{LEVEL} \gg V_{HCH}$	70	100	130	μs
M_{FM}	Highcut Timeconstant Multiplier FM	$V_{LEVEL} \ll V_{HCL}$		3		
$\tau_{DeempAM}$	Deemphasis Timeconstants AM	$V_{LEVEL} \gg V_{HCH}$		37.5		μs
		$V_{LEVEL} \gg V_{HCH}$		47		μs
		$V_{LEVEL} \gg V_{HCH}$		56		μs
		$V_{LEVEL} \gg V_{HCH}$		75		μs
M_{AM}	Highcut Timeconstant Multiplier AM	$V_{LEVEL} \ll V_{HCL}$		3.7		
REF5V	Internal Reference Voltage		4.7	5	5.3	V
L_{min}	min. LEVEL Gain		-1	0	1	dB
L_{maxs}	max. LEVEL Gain		5	6	7	dB
L_{Gstep}	LEVEL Gain Step Resolution	see section 2.7	0.2	0.4	0.6	dB
$VSBL_{min}$	Min. Voltage for Mono	see section 2.8	17	20	23	%REF5V
$VSBL_{max}$	Max. Voltage for Mono	see section 2.8	62	70	78	%REF5V
$VSBL_{step}$	Step Resolution	see section 2.8	1.6	3.3	5.0	%REF5V
$VHCH_{min}$	Min. Voltage for NO Highcut	see section 2.9	37	42	47	%REF5V
$VHCH_{max}$	Max. Voltage for NO Highcut	see section 2.9	58	66	74	%REF5V
$VHCH_{step}$	Step Resolution	see section 2.9	4.2	8.4	12.6	%REF5V
$VHCL_{min}$	Min. Voltage for FULL High cut	see section 2.9	15	17	19	%VHCH
$VHCL_{max}$	Max. Voltage for FULL High cut	see section 2.9	29	33	37	%VHCH
$VHCL_{step}$	Step Resolution	see section 2.9	2.1	4.2	6.3	%REF5V
Carrier and harmonic suppression at the output						
α_{19}	Pilot Signalf=19kHz		40	50		dB
α_{38}	Subcarrier f=38kHz			75		dB
α_{57}	Subcarrier f=57kHz			62		dB
α_{76}	Subcarrier f=76kHz			90		dB

Table 3. ELECTRICAL CHARACTERISTICS (continued)

$V_S = 9V$, deemphasis time constant = 50 μ s, MPX input voltage $V_{MPX} = 500mV$ (75kHz deviation), modulation frequency = 1kHz, input gain = 6dB, $T_{amb} = 27^\circ C$, unless otherwise specified.

Symbol	Parameter	Test Conditions	Min.	Typ.	Max.	Unit
Intermodulation (Note 1)						
α_2	$f_{mod}=10kHz, f_{spur}=1kHz$			65		dB
α_3	$f_{mod}=13kHz, f_{spur}=1kHz$			75		dB
Traffic Radio (Note 2)						
α_{57}	Signal $f=57kHz$			70		dB
SCA - Subsidiary Communications Authorization (Note 3)						
α_{67}	Signal $f=67kHz$			75		dB
ACI - Adjacent Channel Interference (Note 4)						
α_{114}	Signal $f=114kHz$			95		dB
α_{190}	Signal $f=190kHz$			84		dB

Notes to the Characteristics

Note 1. Intermodulation Suppression

$$\alpha_2 = \frac{V_o(\text{signal})(\text{at}1\text{kHz})}{V_o(\text{spurious})(\text{at}1\text{kHz})}; f_s = (2 \cdot 10\text{kHz}) - 19\text{kHz}$$

$$\alpha_3 = \frac{V_o(\text{signal})(\text{at}1\text{kHz})}{V_o(\text{spurious})(\text{at}1\text{kHz})}; f_s = (3 \cdot 13\text{kHz}) - 38\text{kHz}$$

measured with: 91% pilot signal; $f_m = 10\text{ kHz}$ or 13 kHz .

Note 2. Traffic Radio (V.F.) Suppression

measured with: 91% stereo signal; 9% pilot signal; $f_m=1\text{kHz}$; 5% subcarrier ($f=57\text{kHz}$, $f_m=23\text{Hz}$ AM, $m=60\%$)

$$\alpha_{57}(\text{V.W.F.}) = \frac{V_o(\text{signal})(\text{at}1\text{kHz})}{V_o(\text{spurious})(\text{at}1\text{kHz} \pm 23\text{kHz})}$$

Note 3. SCA (Subsidiary Communications Authorization)

$$\alpha_{67} = \frac{V_o(\text{signal})(\text{at}1\text{kHz})}{V_o(\text{spurious})(\text{at}9\text{kHz})}; f_s = (3 \cdot 38\text{kHz}) - 67\text{kHz}$$

measured with: 81% mono signal; 9% pilot signal; $f_m=1\text{kHz}$; 10%SCA - subcarrier ($f_s = 67\text{kHz}$, unmodulated).

Note 4. ACI (Adjacent Channel Interference)

$$\alpha_{114} = \frac{V_o(\text{signal})(\text{at}1\text{kHz})}{V_o(\text{spurious})(\text{at}4\text{kHz})}; f_s = 110\text{kHz} - (3 \cdot 38\text{kHz})$$

$$\alpha_{190} = \frac{V_o(\text{signal})(\text{at}1\text{kHz})}{V_o(\text{spurious})(\text{at}4\text{kHz})}; f_s = 186\text{kHz} - (5 \cdot 38\text{kHz})$$

measured with: 90% mono signal; 9% pilot signal; fm=1kHz; 1% spurious signal (fs = 110kHz or 186kHz, unmodulated).

NOISE BLANKER PART

Features:

- AM and FM mode
- internal 2nd order 140kHz high-pass filter for MPX path
- internal rectifier and filters for AM-IF path
- programmable trigger thresholds
- trigger threshold dependent on high frequency noise with programmable gain
- additional circuits for deviation- and fieldstrength-dependent trigger adjustment
- 4 selectable pulse suppression times for each mode
- programmable noise rectifier charge/discharge current

Table 4. ELECTRICAL CHARACTERISTICS

All parameters mesured in FM mode if not otherwise specified.

Symbol	Parameter	Test conditions	Min.	Typ.	Max.	Unit
V _{TR}	Trigger Threshold ⁵⁾	meas.with V _{PEAK} =0.9V	111		30	mV _{OP}
			110		35	mV _{OP}
			101		40	mV _{OP}
			100		45	mV _{OP}
			011		50	mV _{OP}
			010		55	mV _{OP}
			001		60	mV _{OP}
			000		65	mV _{OP}
V _{TRNOISE}	noise controlled Trigger Threshold	meas.with V _{PEAK} =1.5V	00		260	mV _{OP}
			01		220	mV _{OP}
			10		180	mV _{OP}
			11		140	mV _{OP}

Table 4. ELECTRICAL CHARACTERISTICS (continued)

All parameters measured in FM mode if not otherwise specified.

Symbol	Parameter	Test conditions		Min.	Typ.	Max.	Unit
V _{RECT}	Rectifier Voltage	V _{MPX} =0mV		0.5	0.9	1.3	V
		V _{MPX} =50mV, f=150kHz		1.5	1.7	2.1	V
		V _{MPX} =200mV, f=150kHz		2	2.5	2.9	V
V _{RECTDEV}	Deviation dependent Rectifier Voltage	meas.with V _{MPX} =500mV (75kHz dev.)	11	0.5	0.9 (off)	1.3	V _{OP}
			10	0.9	1.2	1.5	V _{OP}
			01	1.7	2.0	2.3	V _{OP}
			00	2.5	2.8	3.1	V _{OP}
V _{RECTFS}	Fieldstrength controlled Rectifier Voltage	meas.with V _{MPX} =0mV, V _{LEVEL} << V _{SBL} (fully mono)	11	0.5	0.9 (off)	1.3	V
			10	0.9	1.4	1.5	V
			01	1.7	1.9	2.3	V
			00	2.1	2.4	3.1	V
T _{SFM}	Suppression Pulse Duration FM	Signal HOLDN in Testmode	00		38		µs
			01		25.5		µs
			10		32		µs
			11		22		µs
T _{SAM}	Suppression Pulse Duration AM	Signal HOLDN in Testmode	00		1.2		ms
			01		800		µs
			10		1.0		ms
			11		640		µs
V _{RECTADJ}	Noise rectifier discharge adjustment	Signal PEAK in Testmode	00		0.3		V/ms
			01		0.8		
			10		1.3		
			11		2.0		
SR _{PEAK}	Noise rectifier charge	Signal PEAK in Testmode	0		10		mV/µs
			1		20		
V _{ADJMP}	Noise rectifier adjustment through Multipath	Signal PEAK in Testmode	00		0.3		V/ms
			01		0.5		
			10		0.7		
			11		0.9		
R _{AMIF}	AM IF Input resistance			35	50	65	kOhm
G _{AMIF,min}	min. gain AM IF	Signal AM-RECTIFIER in Testmode			6		dB
G _{AMIF,max}	max. gain AM IF				20		dB
G _{AMIF,step}	step gain AM IF				2		dB
f _{AMIF,min}	min. f _c AM IF	Signal AM-RECTIFIER in Testmode			14		kHz
f _{AMIF,max}	max. f _c AM IF				56		kHz

5. All thresholds are measured using a pulse with T_R = 2 µs, THIGH= 2 µs and T_F = 10 µs. The repetition rate must not increase the PEAK voltage.

Figure 21. Noiseblanker Test-Pulse

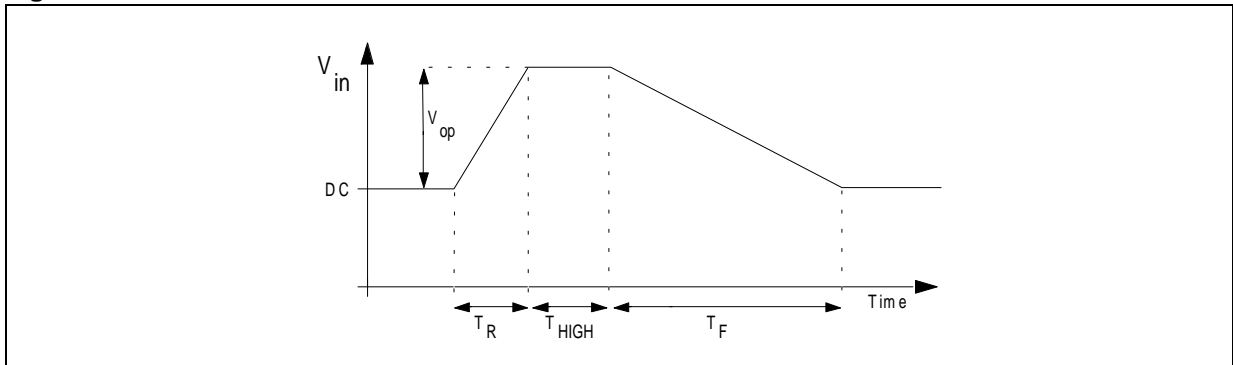

Figure 22. Trigger Threshold vs. VPEAK

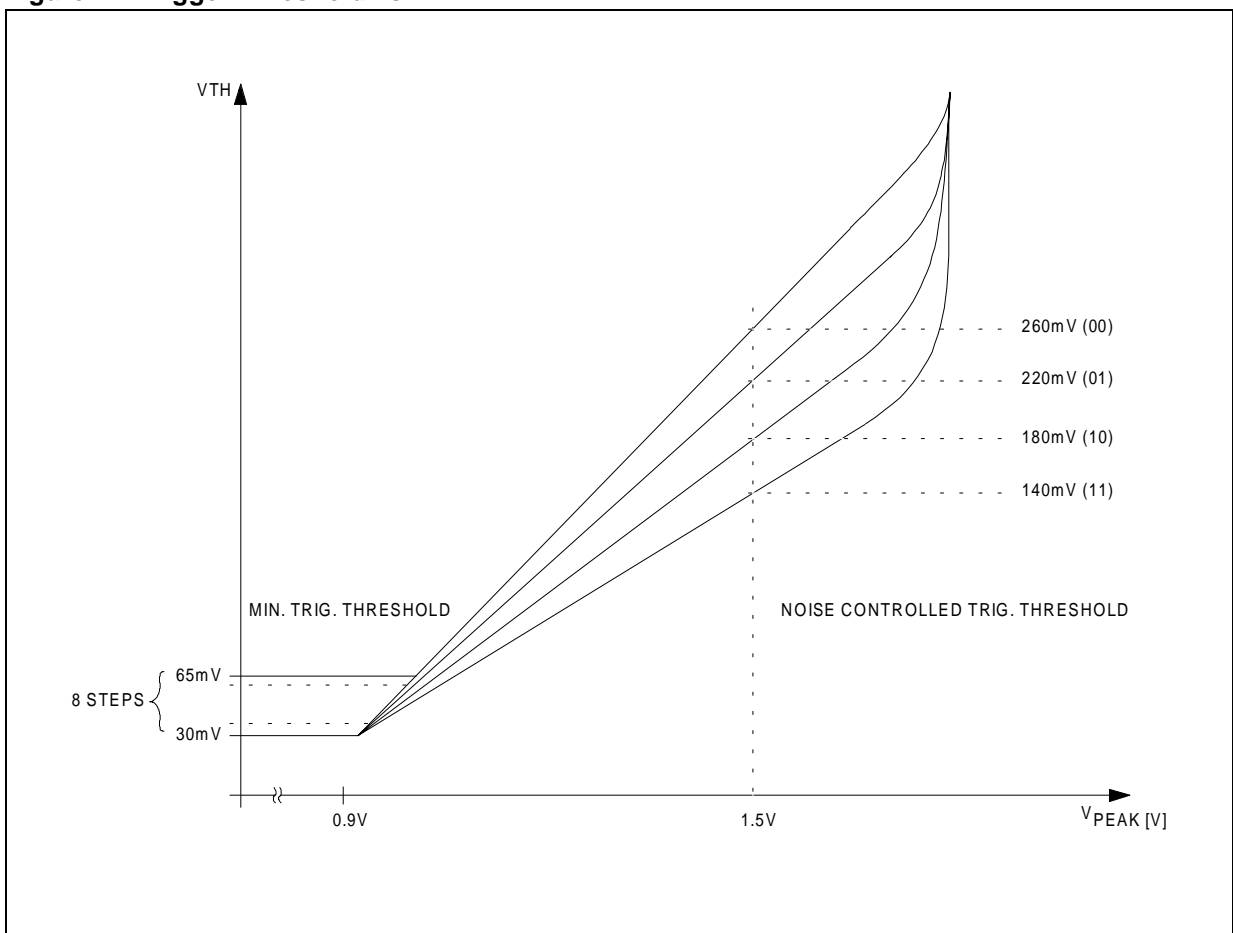

Figure 23.

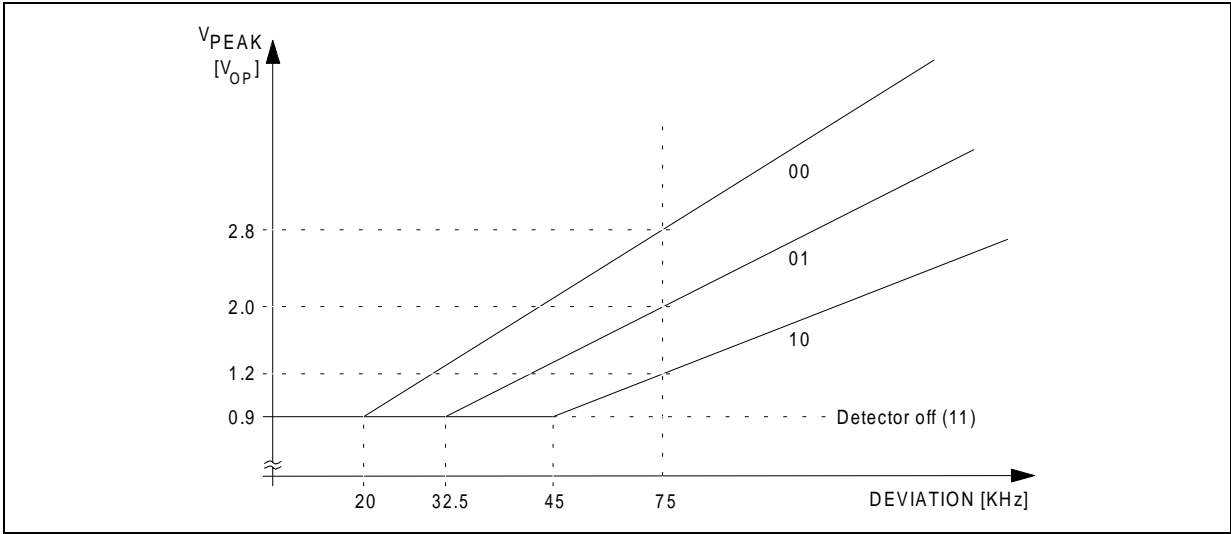
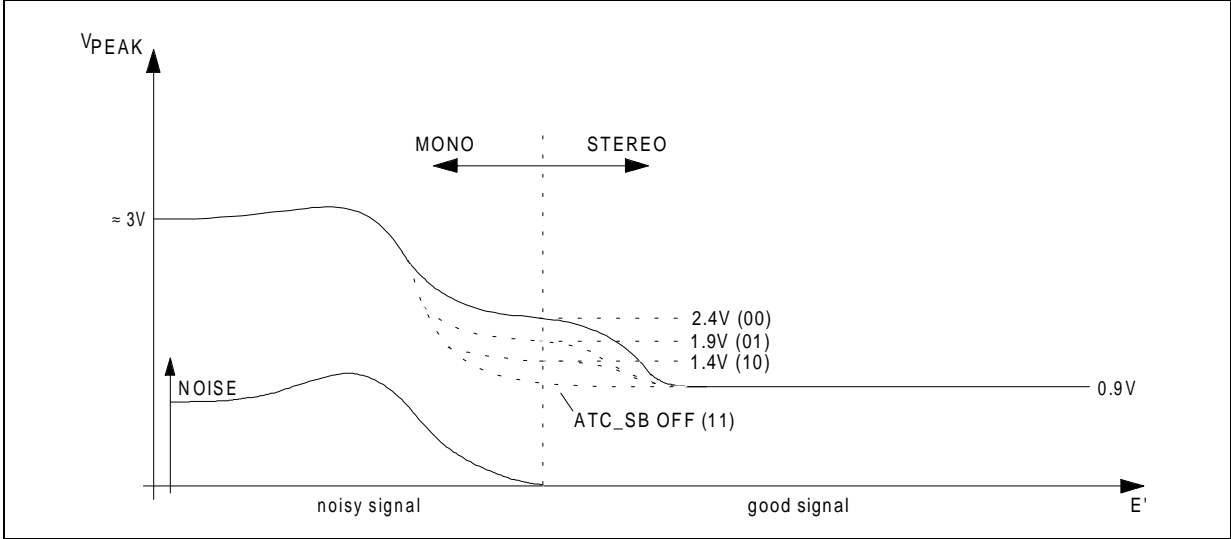

Figure 24. Fieldstrength Controlled Trigger Adjustment



MULTIPATH DETECTOR

Features:

- internal 19kHz band-pass filter
- programmable band-pass- and rectifier-gain
- selectable internal influence on Stereoblend and/or Highcut

Table 5. ELECTRICAL CHARACTERISTICS

Symbol	Parameter	Test Conditions	Min.	Typ.	Max.	Unit
f _{CMP}	Center frequency of Multipath-Bandpass	stereodecoder locked on Pilottone		19		kHz
G _{BPMP}	Bandpass Gain	G1		6		dB
		G2		12		dB
		G3		16		dB
		G4		18		dB
G _{RECTMP}	Rectifier Gain	G1		7.6		dB
		G2		4.6		dB
		G3		0		dB
I _{CHMP}	Rectifier Charge Current			0.25 0.5		µA
I _{DISMP}	Rectifier Discharge Current			4		mA
Quality Detector						
A	Multipath Influence Factor	00		0.70		
		01		0.85		
		10		1.00		
		11		1.15		

4 FUNCTIONAL DESCRIPTION OF STEREODECODER

Figure 25. Blockdiagram of the Stereodecoder

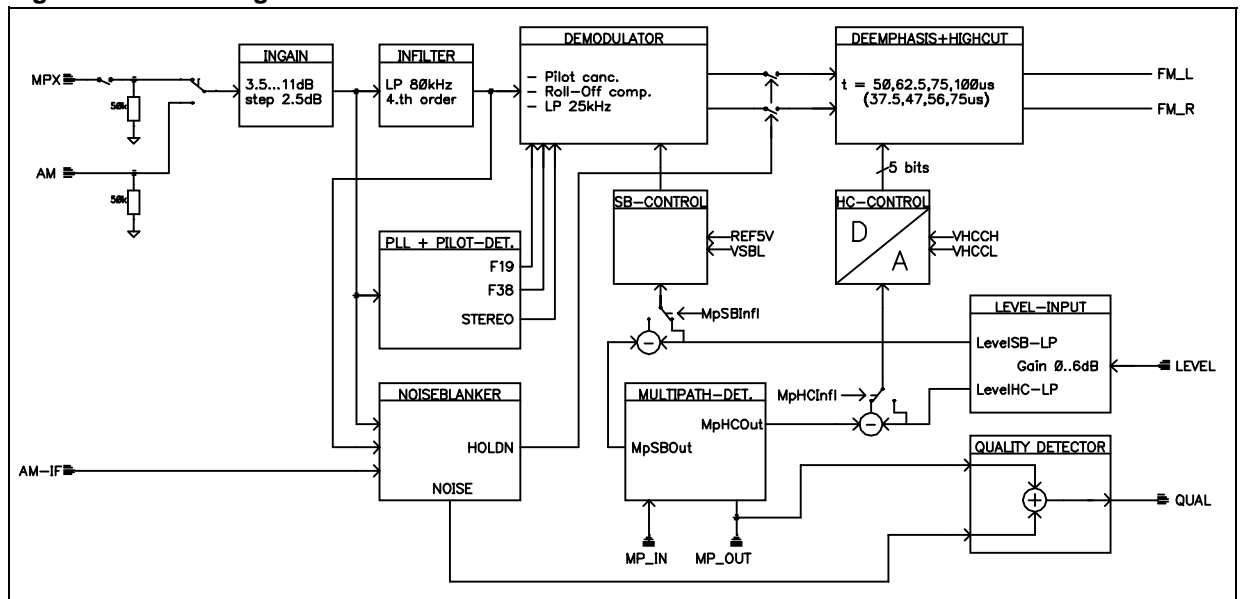

The stereodecoder-part of the A631 (see Figure 25) contains all functions necessary to demodulate the MPX-signal like pilot-tone-dependent MONO/STEREO-switching as well as "stereoblend" and "highcut". Adaptations like programmable input gain, roll-off compensation, selectable deemphasis time constant and a programmable fieldstrength input allow to use different IF-devices.

4.1 Stereodecoder-Mute

The A631 has a fast and easy to control RDS-Mute function which is a combination of the audioprocessor's SoftMute and the high-ohmic mute of the stereodecoder. If the stereodecoder is selected and a SoftMute command is sent (or activated through the SM-pin) the stereodecoder will be set automatically to the high-ohmic mute condition after the audio-signal has been softmuted. Hence a checking of alternate frequencies could be performed. Additionally the PLL can be set to "Hold"-mode, which disables the PLL input during the mute time. To release the system from the mute condition simply the unmute-command must be sent: the stereodecoder is unmuted immediately and the audioprocessor is softly unmuted. Figure 26 shows the output-signal V_O as well as the internal stereodecoder mute signal. This influence of SoftMute on the stereodecoder mute can be switched off by setting bit 3 of the SoftMute byte to "0". A stereodecoder mute command (bit 0, stereodecoder byte set to "1") will set the stereodecoder in any case independently to the high-ohmic mute state.

If any other source than the stereodecoder is selected the decoder remains muted and the MPX-pin is connected to V_{ref} to avoid any discharge of the coupling capacitor through leakage currents. No further mute command should be applied.

Figure 26. Signals during stereodecoder's SoftMute

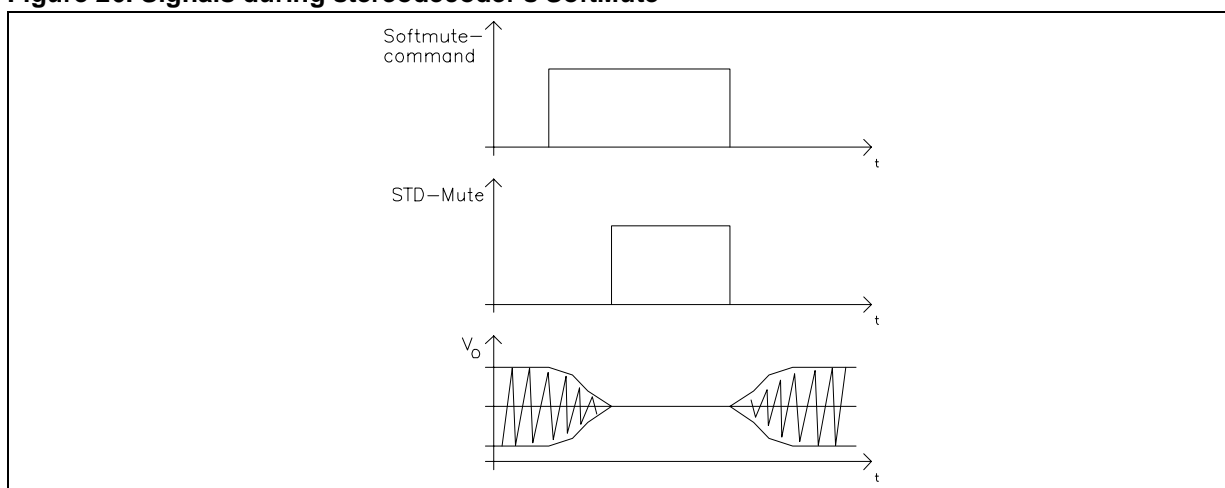
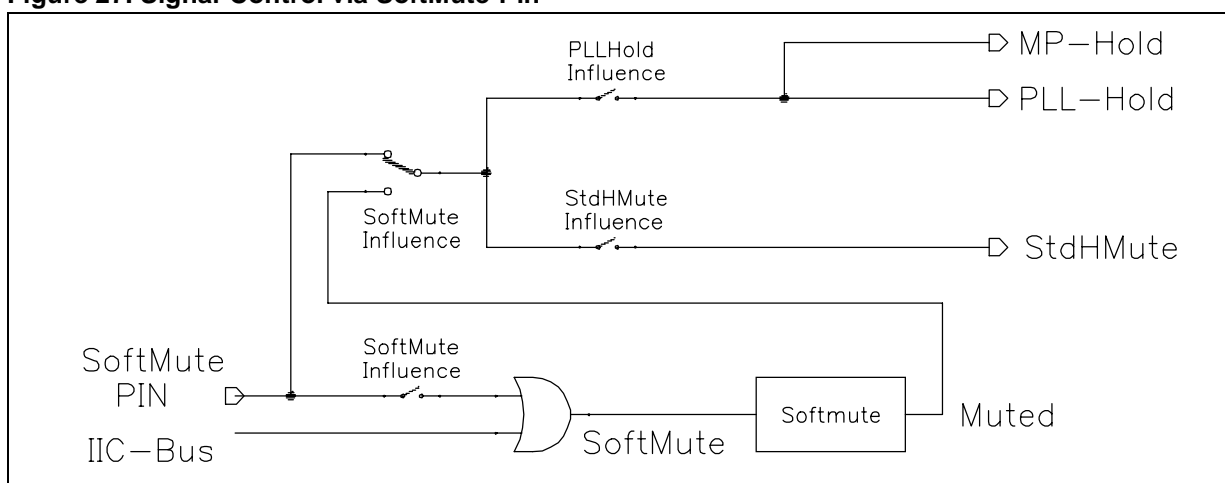

Figure 27. Signal-Control via SoftMute-Pin



4.2 InGain + Infilter

The InGain stage allows to adjust the MPX-signal to a magnitude of about 1V_{rms} internally which is the recommended value. The 4.th order input filter has a corner frequency of 80kHz and is used to attenuate spikes and noise and acts as an anti-aliasing filter for the following switch capacitor filters.

4.3 Demodulator

In the demodulator block the left and the right channel are separated from the MPX-signal. In this stage also the 19-kHz pilotone is cancelled. For reaching a high channel separation the A631 offers an I²C-bus programmable roll-off adjustment which is able to compensate the lowpass behavior of the tuner section. If the tuner's attenuation at 38kHz is in a range from 7.2% to 31.0% the A631 needs no external network in front of the MPX-pin. Within this range an adjustment to obtain at least 40 dB channel separation is possible. The bits for this adjustment are located together with the fieldstrength adjustment in one byte. This gives the possibility to perform an optimization step during the production of the carradio where the channel separation and the fieldstrength control are trimmed. The setup of the Stereoblend characteristics which is programmable in a wide range is described in 2.8.

4.4 Deemphasis and Highcut

.The deemphasis-lowpass allows to choose a time constant between 37.5 and 100μs. The highcut control range will be $2 \times t_{Deemp}$ or $2.7 \times t_{Deemp}$ dependent on the selected time constant (see programming section). The bit D7 of the highcut-byte will shift timeconstant and range.

Inside the highcut control range (between VHCH and VHCL) the LEVEL signal is converted into a 5 bit word which controls the lowpass time constant between $t_{Deemp} \dots 3 (3.7) \times t_{Deemp}$. Thereby the resolution will remain always 5 bits independently of the absolute voltage range between the VHCH- and VHCL-values. In addition the maximum attenuation can be fixed between 2 and 10dB.

The highcut function can be switched off by I²C-bus (bit D7, Highcut byte set to "0").

The setup of the highcut characteristics is described in 4.9.

4.5 PLL and Pilotone-Detector

The PLL has the task to lock on the 19kHz pilotone during a stereo-transmission to allow a correct demodulation. The included pilotone-detector enables the demodulation if the pilotone reaches the selected pilotone threshold VPTHST. Two different thresholds are available. The detector output (signal STEREO, see Blockdiagram) can be checked by reading the status byte of the A631 via I²C-bus. During a Softmute the PLL can be set into "Hold"-mode which freezes the PLL's state (bit D4, Softmute byte). After releasing the Softmute the PLL will again follow the input signal only by correcting the phase error.

4.6 Fieldstrength Control

The fieldstrength input is used to control the highcut- and the stereoblend-function. In addition the signal can be also used to control the noiseblanker thresholds and as input for the multipath detector. These additional functions are described in sections 3.3 and 4.

4.7 LEVEL-Input and -Gain

To suppress undesired high frequency modulation on the highcut- and stereoblend-control signal the LEVEL signal is lowpass filtered firstly. The filter is a combination of a 1.st-order RC-lowpass at 53kHz (working as anti-aliasing filter) and a 1.st-order switched-capacitor-lowpass at 2.2kHz. The second stage is a programmable gain stage to adapt the LEVEL signal internally to different IF-devices (see Testmode section 5: LEVELHCC). The gain is widely programmable in 16 steps from 0dB to 6dB (step=0.4dB). These 4 bits are located together with the Roll-Off bits in the "Stereodecoder-Adjustment"-byte to simplify a possible adjustment during the production of the carradio. This signal controls directly the Highcut stage whereas the signal is filtered again ($f_c=100\text{Hz}$) before the stereoblend stage (see Figure 25).

4.8 Stereoblend Control

The stereoblend control block converts the internal LEVEL-voltage (LEVELSB) into an demodulator compatible analog signal which is used to control the channel separation between 0dB and the maximum separation. Internally this control range has a fixed upper limit which is the internal reference voltage REF5V. The lower limit can be programmed between 20 and 70% of REF5V in 3.3% steps (see Figure 28, Figure 29).

To adjust the external LEVEL-voltage to the internal range two values must be defined: the LEVEL gain LG and VSBL (see Figure 29). At the point of full channel separation the external level signal has to be amplified that internally it becomes equal to REF5V. The second point (e.g. 10dB channel sep.) is then adjusted with the VSBL voltage.

Figure 28. Internal stereoblend characteristics

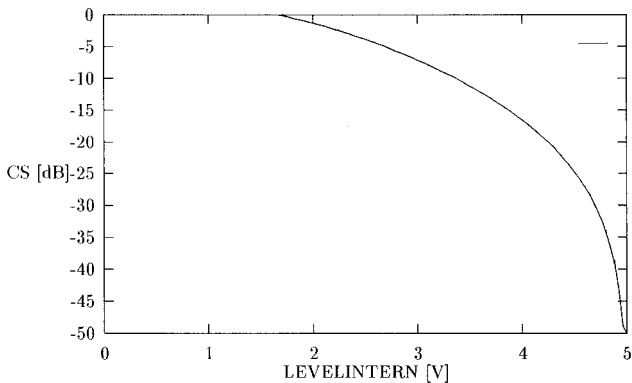

The gain can be programmed through 4 bits in the "Stereodecoder-Adjustment"-byte. All necessary internal reference voltages like REF5V are derived from a bandgap circuit. Therefore they have a temperature coefficient near zero.

Figure 29. Relation between internal and external LEVEL-voltages for setup of Stereoblend

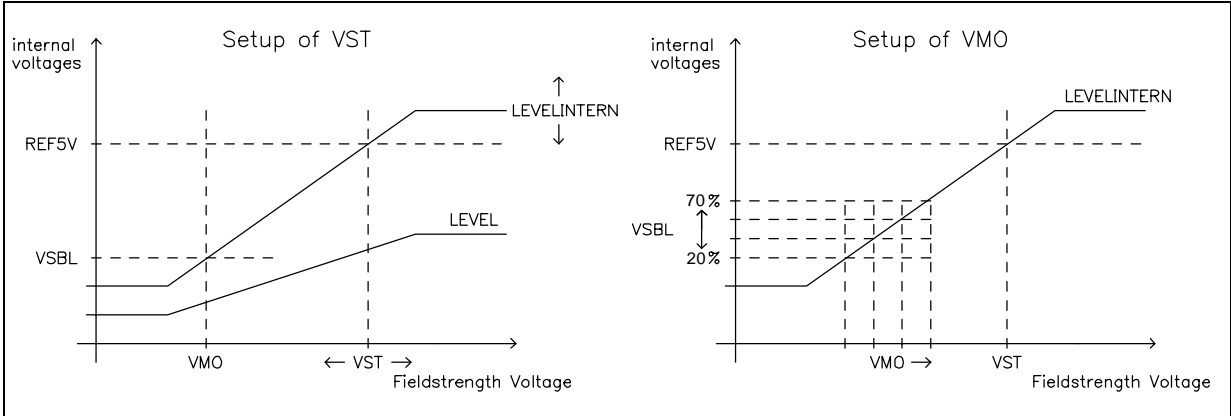

4.9 Highcut Control

The highcut control setup is similar to the stereoblend control setup : the starting point VHCH can be set with 2 bits to be 42, 50, 58 or 66% of REF5V whereas the range can be set to be 17, 22, 28 or 33% of VHCH (see Figure 30).

Figure 30. Highcut characteristics

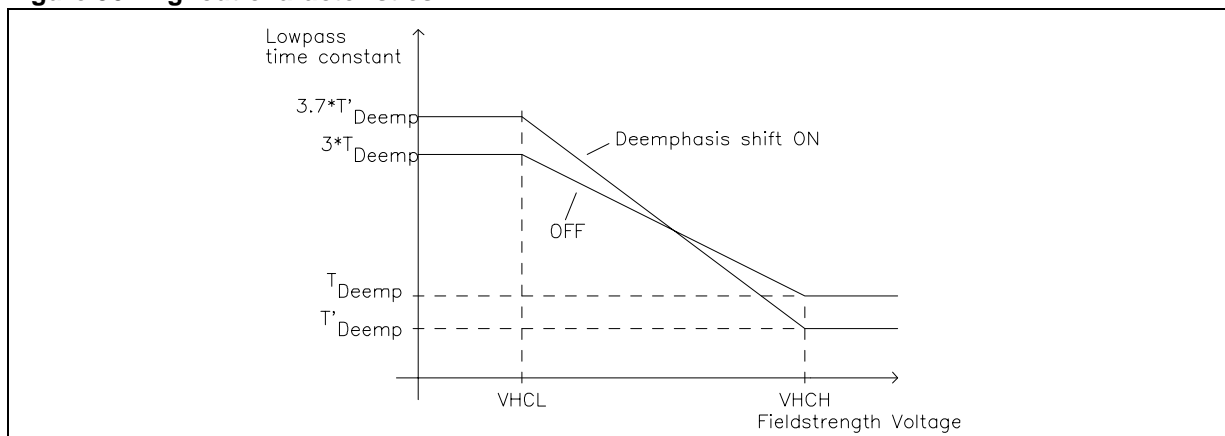

5 FUNCTIONAL DESCRIPTION OF THE NOISEBLANKER

In the automotive environment the MPX-signal as well as the AM-signal is disturbed by spikes produced by the ignition and other radiating sources like the wiper-motor. The aim of the noiseblanker part is to cancel the audible influence of the spikes. Therefore the output of the stereodecoder is held at the actual voltage for a time between 22 and 38µs in FM (370 and 645µs in AM-mode). The blockdiagram of the noiseblanker is given in Figure 31.

Figure 31. Block diagram of the noiseblanker

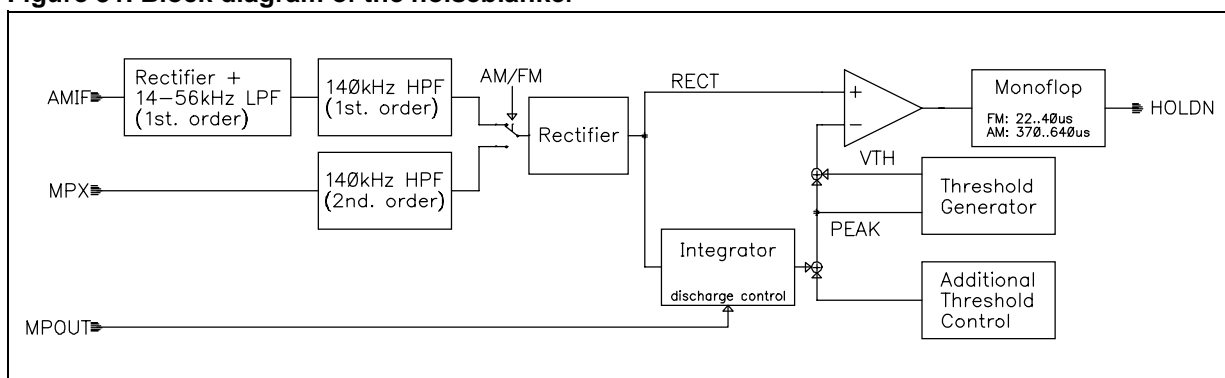

In a first stage the spikes must be detected but to avoid a wrong triggering on high frequency (white) noise a complex trigger control is implemented. Behind the triggerstage a pulse former generates the "blanking"-pulse.

5.1 Trigger Path FM

The incoming MPX signal is highpass-filtered, amplified and rectified. This second order highpass-filter has a corner-frequency of 140kHz. The rectified signal, RECT, is integrated (lowpass filtered) to generate a signal called PEAK. The DC-charge/discharge behaviour can be adjusted as well as the transient behaviour(MP-discharge control). Also noise with a frequency 140kHz increases the PEAK voltage. The PEAK voltage is fed to a threshold generator, which adds to the PEAK-voltage a DC-dependent threshold VTH. Both signals, RECT and PEAK+VTH are fed to a comparator which triggers a re-triggerable monoflop. The monoflop's output activates the sample-and-hold circuits in the signalpath for the selected duration

5.2 Noise Controlled Threshold Adjustment (NCT)

There are mainly two independent possibilities for programming the trigger threshold:

1. the low threshold in 8 steps (bits D₁ to D₃ of the noiseblanker-byte I)
2. and the noise adjusted threshold in 4 steps (bits D₄ and D₅ of the noiseblanker-byte I, see Figure 22).

The low threshold is active in combination with a good MPX signal without noise; the PEAK voltage is less than 1V. The sensitivity in this operation is high. If the MPX signal is noisy (low fieldstrength) the PEAK voltage increases due to the higher noise, which is also rectified. With increasing of the PEAK voltage the trigger threshold increases, too. This gain is programmable in 4 steps (see Figure 22).

5.3 Additional Threshold Control Mechanism

5.3.1 Automatic Threshold Control by the Stereoblend voltage

Besides the noise controlled threshold adjustment there is an additional possibility for influencing the trigger threshold which depends on the stereoblend control.

The point where the MPX signal starts to become noisy is fixed by the RF part. Therefore also the starting point of the normal noise-controlled trigger adjustment is fixed (Figure 24). In some cases the behavior of the noise-blanker can be improved by increasing the threshold even in a region of higher fieldstrength. Sometimes a wrong triggering occurs for the MPX signal often shows distortion in this range which can be avoided even if using a low threshold. Because of the overlap of this range and the range of the stereo/mono transition it can be controlled by stereoblend. This increase of the threshold is programmable in 3 steps or switched off.

5.3.2 Over Deviation Detector

If the system is tuned to stations with a high deviation the noiseblanker can trigger on the higher frequencies of the modulation or distortion. To avoid this behavior, which causes audible noise in the output signal, the noiseblanker offers a deviation-dependent threshold adjustment. By rectifying the MPX signal a further signal representing the actual deviation is obtained. It is used to increase the PEAK voltage. Offset and gain of this circuit are programmable in 3 steps with the bits D₆ and D₇ of the noiseblanker-byte I (bit combination '00' turns off the detector, see Figure 23).

5.3.3 Multipath-Level

To react on high repetitive spikes caused by a Multipath-situation, the discharge-time of the PEAK voltage can be decreased depending on the voltage-level at pin MPout. The A631 offers a linear as well as a threshold driven control. The linear influence of the Multipath-Level on the PEAK-signal (D₇ of Multipath-Control-Byte) gives a discharge slewrate of 1V/ms¹. The second possibility is to activate the threshold driven discharge which switches on the 18kOhm discharge if the Multipath-Level is below 2.5V (D₇ of noiseblanker-byte II-byte).

¹ The slewrate is measured with R_{Discharge} = nfinite and V_{MPout} = 2.5V

5.3.4 AM mode of the Noiseblanker

The A631 noiseblanker is also suitable for AM noise canceling. The detector uses in AM mode the 450kHz unfiltered IF-output of the tuner for spike detection. A combination of programmable gain-stage and lowpass-filter forms an envelope detector which drives the noiseblanker's input via a 120 kHz 1.st order highpass. In order to blank the whole spike in AM mode the hold-times of the sample and hold circuit are much longer than in FM (640µs to 1.2ms). All threshold controls can be used like in FM mode.

5.4 Functional Description of the Multipath-Detector

Using the Multipath-Detector the audible effects of a multipath condition can be minimized. A multipath-condition is detected by rectifying the spectrum around 19kHz in the fieldstrength signal. An external capacitor is used to define the attack- and decay-times for the Stereoblend (see blockdiagram, Figure 32). Due to the very small charge currents this capacitor should be a low leakage current type (e.g. ceramic). Using this configuration an adaptation to the user's requirement is possible without effecting the "normal" fieldstrength input (LEVEL) for the stereodecoder. This application is given in Figure 32. Another (internal) time constant is used to control the Highcut through the multipath detector

Selecting the "internal influence" in the configuration byte the Stereo-Blend and/or the Highcut is automatically invoked during a multipath condition according to the voltage appearing at the MP_OUT-pin.

Figure 32. Blockdiagram of the Multipath-Detector

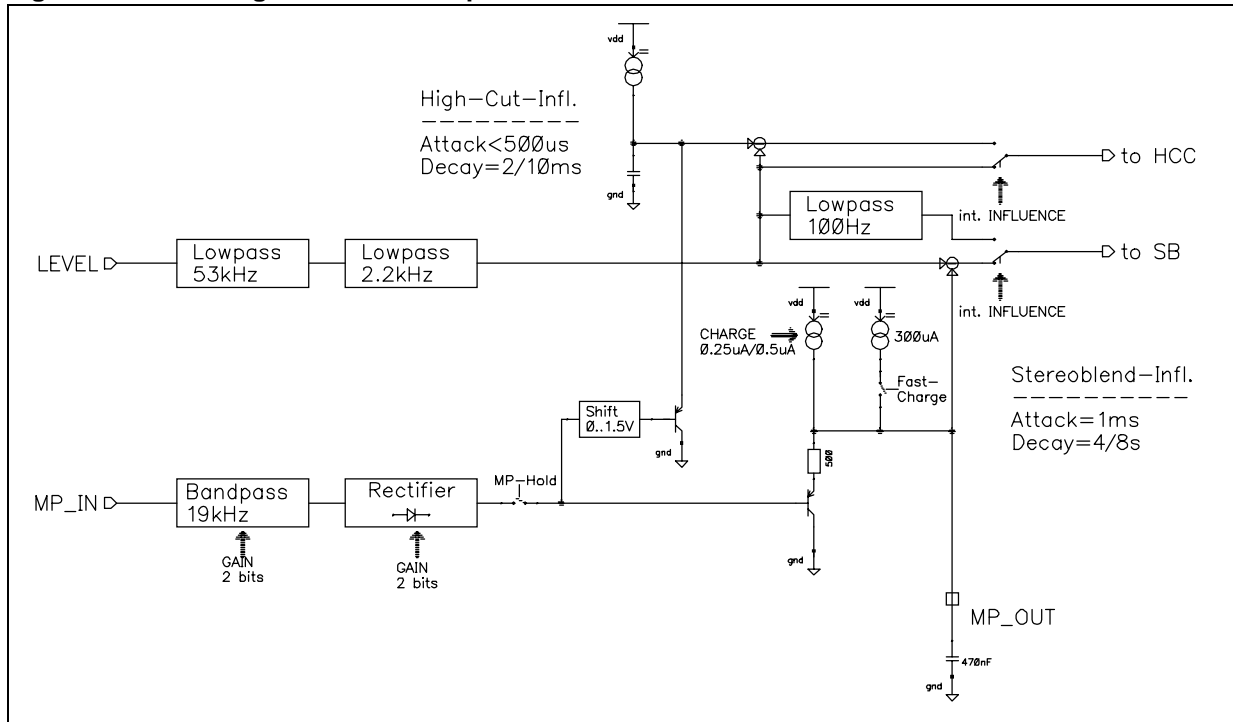

5.5 Quality Detector

The TDA7405 offers a quality detector output which gives a voltage representing the FM-reception conditions. To calculate this voltage the MPX-noise and the multipath-detector output are summed according to the following formula :

$$V_{Qual} = 1.6 (V_{Noise} - 0.8 V) + a (REF5V - V_{Mpout}).$$

The noise-signal is the PEAK-signal without additional influences (see noiseblanker description). The factor 'a' can be programmed to 0.7 1.15. The output is a low impedance output able to drive external circuitry as well as simply fed to an AD-converter for RDS applications.

5.6 Dual-MPX Mode

The TDA7405 is able to support a twin tuner concept via the Dual-MPX-Mode. In this configuration the MPX-pin and the MD2G-pin are acting as MPX1 and MPX2 inputs. The DC-Voltage at the MD2-pin controls whether one or both MPX-signals are used to decode the stereo FM-signal. It is designed as a window-comparator with the characteristic shown in Figure 33 (Please note that the thresholds have a hysteresis of 500mV). In this mode the stereodecoder highohmic-mute mutes both inputs in parallel.

Figure 33. Blockdiagram Dual MPX

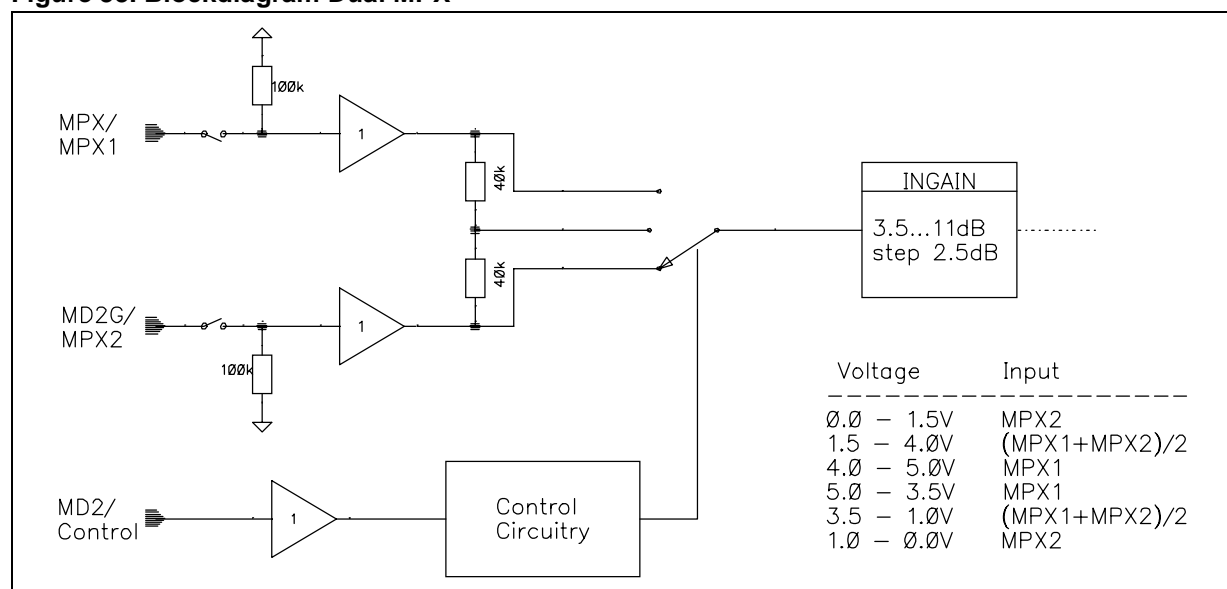

Table 6. Pin-Configuration DMPX-/WSM-Mode

Dual MPX	Weak-Signal Mute	AMIF(12)	DMPXC(25)	MPX2(26)	MD2(43)	MD2G(44)
off	off	AMIF-In	not used	not used	MD2-In	MD2-Gnd
off	on	WSM-TC	WSM-In	WSM-Out	MD2-In	MD2-Gnd
on	off	AMIF-In	DMPC-Cntrl	MPX2	MD2-In	MD2-Gnd
on	on	WSM-TC	WSM-In	WSM-Out	DMPC-Cntrl	MPX2

5.7 Weak-Signal Mute

For use with front-ends which do not support a weak-signal-mute function the TDA7405 offers this feature as well. If this mode is enabled the pins 26 and 27 are used as an AC-coupling behind the Mute-Stage (see block-diagram). In parallel pin 12 (AMIF) is switched internally to realize a mute time-constant with fast attack- and slow decay-time.

Figure 34. Weak-Signal Mute-Depth @ 0.5V Threshold

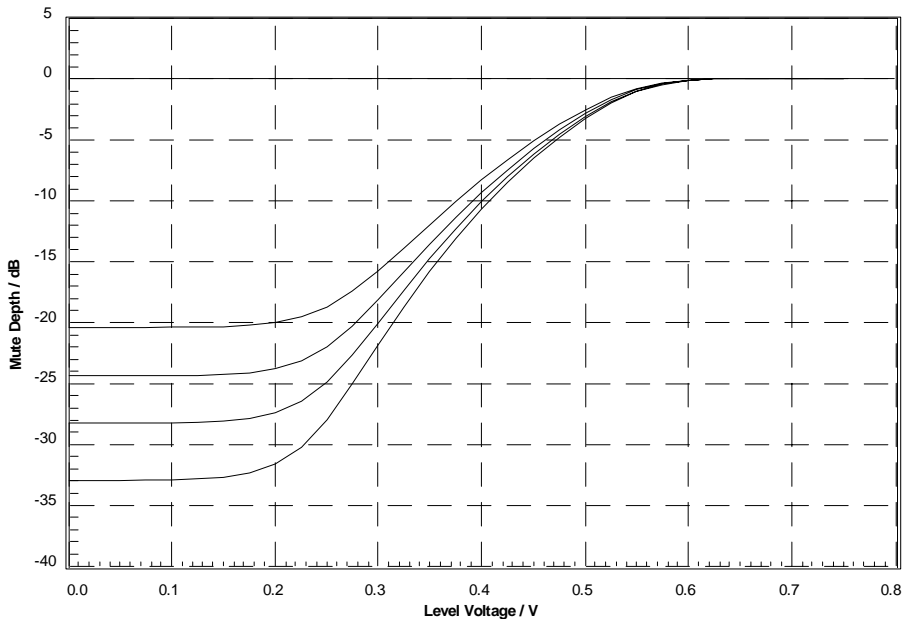
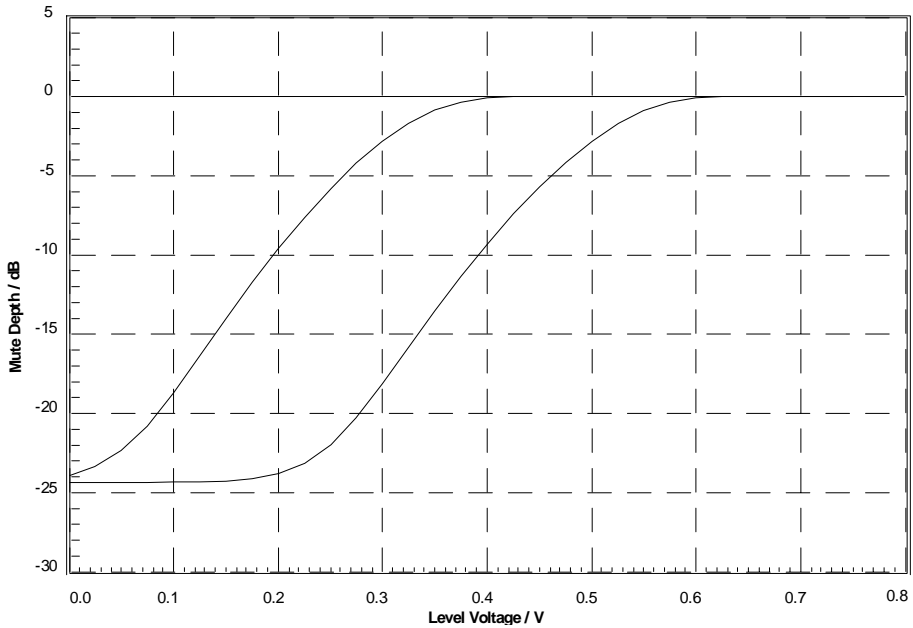

Figure 35. Weak-Signal Mute-Threshold @ 24dB Mute-Depth



5.8 Stereodecoder Testmode

During the Testmode, which can be activated by setting bit D0 and bit D1 of the stereodecoder testing-byte, several internal signals are available at the FD2R+ pin. During this mode the input resistance of 100kOhm is disconnected from the pin. The internal signals available are shown in the Data-byte specification.

6 I²C BUS INTERFACE

6.1 Interface Protocol

The interface protocol comprises:

- a start condition (S)
- a chip address byte (the LSB bit determines read / write transmission)
- a subaddress byte
- a sequence of data (N-bytes + acknowledge)
- a stop condition (P)

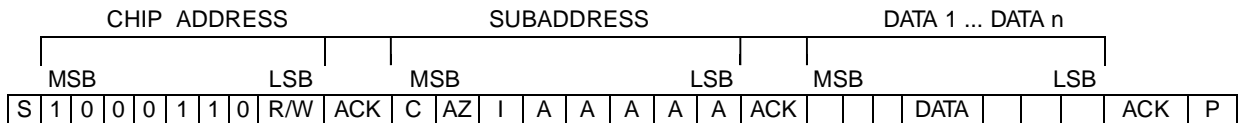

S = Start
 R/W = "0" -> Receive-Mode (Chip could be programmed by μP)
 "1" -> Transmission-Mode (Data could be received by μP)
 ACK = Acknowledge
 P = Stop
 MAX CLOCK SPEED 500kbts/s

6.1.1 Auto increment

If bit I in the subaddress byte is set to "1", the autoincrement of the subaddress is enabled.

6.1.2 TRANSMITTED DATA (send mode)

MSB					LSB		
X	X	X	X	X	P	ST	SM

SM = Soft mute activated
 ST = Stereo
 P = Pause
 X = Not Used

The transmitted data is automatically updated after each ACK. Transmission can be repeated without new chip-address.

6.1.3 Reset Condition

A Power-On-Reset is invoked if the Supply-Voltage is below than 3.5V. After that the following data is written automatically into the registers of all subaddresses :

MSB							LSB
1	1	1	1	1	1	1	0

The programming after POR is marked bold-face / underlined in the programming tables.
 With this programming all the outputs are muted to V_{REF} (V_{OUT}= V_{DD}/2).



6.3 DATA BYTE SPECIFICATION

The status after Power-On-Reset is marked bold-face / underlined in the programming tables.

Table 7. Main Selector (0)

MSB							LSB	FUNCTION
D7	D6	D5	D4	D3	D2	D1	D0	
					0	0	0	Source Selector FD1 / SE2
					0	0	1	SE3
					0	1	0	FD2
					0	1	1	SE1
					1	0	0	MD2
					1	0	1	MD1 / SE4
					1	1	0	<u>Stereodecoder</u>
					1	1	1	AM
	0	0	0	0				Input Gain 0dB
	0	0	0	1				1dB
	:	:	:	:				:
	1	1	1	0				14dB
	1	1	1	1				<u>15dB</u>
0								Mute off
1								<u>on</u>

Table 8. Loudness (1)

MSB							LSB	FUNCTION
D7	D6	D5	D4	D3	D2	D1	D0	
			0	0	0	0	0	Attenuation 0 dB
			0	0	0	0	1	-1 dB
			:	:	:	:	:	:
			0	1	1	1	0	-14 dB
			0	1	1	1	1	-15 dB
			:	:	:	:	:	:
			1	0	0	1	1	-19 dB
			:	:	:	:	:	not allowed
	0	0						Center Frequency 200Hz
	0	1						400Hz
	1	0						600Hz
	1	1						<u>800Hz</u>
0								Loudness Order First Order
1								<u>Second Order</u>

Table 9. Volume¹⁾ (2)

MSB							LSB	ATTENUATION
D7	D6	D5	D4	D3	D2	D1	D0	
0	0	0	0	0	0	0	0	Gain/Attenuation (+32.0dB)
0	0	0	0	0	0	0	1	(+31.5dB)
:	:	:	:	:	:	:	:	:
0	0	0	1	1	0	0	0	+20.0dB
0	0	0	1	1	0	0	1	+19.5dB
0	0	0	1	1	0	1	0	+19.0dB
:	:	:	:	:	:	:	:	:
0	0	1	1	1	1	1	1	+0.5dB
0	1	0	0	0	0	0	0	0.0dB
0	1	0	0	0	0	0	1	-0.5dB
:	:	:	:	:	:	:	:	:
1	1	0	1	1	1	1	0	-79.0dB
1	1	0	1	1	1	1	1	<u>-79.5dB</u>

Note: 1. It is not recommended to use a gain more than 20dB for system performance reason. In general, the max. gain should be limited by software to the maximum value, which is needed for the system.

Table 10. Treble Filter (3)

MSB							LSB	FUNCTION
D7	D6	D5	D4	D3	D2	D1	D0	
			0	0	0	0	0	Treble Steps -15dB
			0	0	0	0	1	-14dB
			:	:	:	:	:	:
			0	1	1	1	0	-1dB
			0	1	1	1	1	0dB
			1	1	1	1	1	0dB
			1	1	1	1	0	<u>+1dB</u>
			:	:	:	:	:	:
			1	0	0	0	1	+14dB
			1	0	0	0	0	+15dB
	0	0						Treble Center-frequency 10.0 kHz
	0	1						12.5 kHz
	1	0						15.0 kHz
	1	1						<u>17.5 kHz</u>
0								Bass DC-Mode On
1								<u>Off</u>

Table 11. Bass Filter (4)

MSB							LSB	FUNCTION
D7	D6	D5	D4	D3	D2	D1	D0	
		0	0	0	0	0	0	Bass Steps
		0	0	0	0	0	1	-15.5dB
		:	:	:	:	:	:	-15.0dB
		0	1	1	1	1	0	-0.5 dB
		0	1	1	1	1	1	0dB
		1	1	1	1	1	1	0dB
		1	1	1	1	1	0	<u>+0.5 dB</u>
		:	:	:	:	:	:	:
		1	0	0	0	0	1	+15.0 dB
		1	0	0	0	0	0	+15.5 dB
0	0							Bass Q-Factor
0	1							1.0
1	0							1.25
1	1							1.5
								<u>2.0</u>

Table 12. Mixing Programming (5)

MSB							LSB	FUNCTION
D7	D6	D5	D4	D3	D2	D1	D0	
							0	Mixing
							1	Mute enable
					0	0		Mixing Source
					0	1		Beep
					1	0		MD1
					1	1		MD2
								<u>FM mono</u>
				0				Mixing Target
				1				Speaker LF off
								<u>Speaker LF on</u>
			0					Speaker RF off
			1					<u>Speaker RF on</u>
		0						Speaker LR off
		1						<u>Speaker LR on</u>
	0							Speaker RR off
	1							<u>Speaker RR on</u>
0								Loudness Main/2nd
1								2nd
								<u>Main</u>

Table 13. SoftMute (6)

MSB							LSB	FUNCTION
D7	D6	D5	D4	D3	D2	D1	D0	
							0 1	SoftMute On (Mute) Off
					0 0 1 1	0 1 0 1		MuteTime 0.48 ms 0.96 ms 123 ms 324 ms
				0 1				Influence on Stereodecoder Highohmic-Mute on off
			0 1					Influence on Pilot-detector Hold and MP-Hold on off
		0 1						Influence on SoftMute on off
0 0 1 1	0 1 0 1							Beep Frequencies 500 Hz 780 Hz 1.8 kHz 19 kHz

Table 14. VoiceBand (7)

MSB							LSB	FUNCTION
D7	D6	D5	D4	D3	D2	D1	D0	
							0 1	Voice-Band Low-Pass Enable Filter off Filter on
						0 1		Voice-Band Low-Pass Frequency 3 kHz 6 kHz
					0 1			Voice-Band High-Pass Enable Filter off Filter on
		0 0 0 1 1 1 1 1	0 0 1 1 0 1 1	0 1 0 1 0 1				High-Pass Cut-Off-Frequency 90Hz 135Hz 180Hz 215Hz 300Hz 450Hz 600Hz 750Hz
	0 1							Anti-Clipping Enable on off
0 1								Anti-Clipping Input MP-In AM

Table 15. Second Source Selector (8)

MSB							LSB	FUNCTION
D7	D6	D5	D4	D3	D2	D1	D0	
					0	0	0	Source Selector
					0	0	1	FD1 / SE2
					0	1	0	SE3
					0	1	1	FD2
					1	0	0	SE1
					1	0	1	MD2
					1	1	0	MD1 / SE4
					1	1	1	<u>Stereodecoder</u>
					1	1	1	AM
	0	0	0	0				Input Gain
	0	0	0	1				0dB
	:	:	:	:				1dB
	1	1	1	0				:
	1	1	1	1				14dB
								<u>15dB</u>
0								Mute
1								off
								<u>on</u>

Table 16. Equalizer (9)

MSB							LSB	FUNCTION
D7	D6	D5	D4	D3	D2	D1	D0	
				0	0	0	0	Frequencies EQ Low-Filter
				0	0	0	1	63 Hz
				0	0	1	0	74 Hz
				0	0	1	1	88 Hz
				0	1	0	0	105 Hz
				0	1	0	1	125 Hz
				0	1	1	0	149 Hz
				0	1	1	1	177Hz
				1	0	0	0	210 Hz
				1	0	0	1	250 Hz
				1	0	1	0	297 Hz
				1	0	1	0	353 Hz
				1	0	1	1	421 Hz
				1	1	0	0	500 Hz
				1	1	0	1	595 Hz
				1	1	1	0	<u>707 Hz</u>
				1	1	1	1	841 Hz
0	0	0	0					Frequencies EQ High-Filter
0	0	0	1					297 Hz
0	0	1	0					353 Hz
0	0	1	1					421 Hz
0	1	0	0					500 Hz
0	1	0	1					595 Hz
0	1	1	0					707 Hz
0	1	1	1					841 Hz
1	0	0	0					1.0 kHz
1	0	0	1					1.19 kHz
1	0	0	1					1.41 kHz
1	0	1	0					1.68 kHz
1	0	1	1					2.0 kHz
1	1	0	0					2.38 kHz
1	1	0	1					2.83 kHz
1	1	1	0					3.36 kHz
1	1	1	1					<u>4.0 kHz</u>

Table 17. EQ-Configuration / Bass (10)

MSB							LSB	FUNCTION
D7	D6	D5	D4	D3	D2	D1	D0	
						0	0	EQ Filter Rear Path no Filter
						0	1	High-Filter
						1	0	Low-Filter
						1	1	High+Low-Filter
				0	0			EQ Filter Front Path no Filter
				0	1			High-Filter
				1	0			Low-Filter
				1	1			High+Low-Filter
			0					AM Noisebl. SoftUnMute On
			1					Off
0	0	0						Bass Center-Frequency 60Hz
0	0	1						80Hz
0	1	0						70Hz
0	1	1						90Hz
1	0	0						100Hz
1	0	1						130Hz
1	1	0						150Hz
1	1	1						200Hz

Table 18. Compander (11)

MSB							LSB	FUNCTION
D7	D6	D5	D4	D3	D2	D1	D0	
						0	0	Activity / Reference Level off
						0	1	0.5V _{RMS}
						1	0	1V _{RMS}
						1	1	2V _{RMS}
				0	0			Attack-Times 6ms
				0	1			12ms
				1	0			24ms
				1	1			49ms
		0	0					Release-Times 390ms
		0	1					780ms
		1	0					1.17s
		1	1					1.56s
	0			0	0			SoftStep-Time¹⁾ 160µs
	0			0	1			320µs
	0			1	0			640µs
	0			1	1			1.28ms
	1	0	0					2.56ms
	1	0	1					5.12ms
	1	1	0					10.2ms
	1	1	1					20.4ms
0								Compander max. Gain 29dB
1								19dB

Note: 1. The SoftStep-Times are only programmable while the Compander is not used.

Table 19. Configuration Audioprocessor I (12)

MSB							LSB	FUNCTION
D7	D6	D5	D4	D3	D2	D1	D0	
							0 1	Compander Source Main Selector Second Source Selector
						0 1		SoftStep off on
					0 1			Main Loudness flat Filter ON
				0 1				Second Loudness flat Filter ON
		0 0 1 1	0 1 0 1					Front Speaker Mute Second Source internal coupled Main Source AC-coupled Main Source internal coupled
0 0 1 1	0 1 0 1							Rear Speaker Mute Second Source internal coupled Main Source AC-coupled Main Source internal coupled

Table 20. Configuration Audioprocessor II (13)

MSB							LSB	FUNCTION
D7	D6	D5	D4	D3	D2	D1	D0	
							0 1	Pause Detector off on
					0 0 1 1	0 1 0 1		Pause ZC Window 160mV 80mV 40mV not allowed
				0 1				FD1 Mode single ended differential
		0 0 1 1	0 1 0 1					FD1 Attenuation -12dB -6dB -6dB 0dB
	0 1							FD2 Attenuation -6dB 0dB
0 1								MD1 Mode single ended differential

Table 21. Equalizer Low-Filter (14)

MSB							LSB		FUNCTION
D7	D6	D5	D4	D3	D2	D1	D0		
			0	0	0	0	0	Gain / Attenuation -15dB	
			0	0	0	0	1	-14dB	
			:	:	:	:	:	:	
			0	1	1	1	0	-1dB	
			0	1	1	1	1	0dB	
			1	1	1	1	1	0dB	
			1	1	1	1	0	<u>+1dB</u>	
			:	:	:	:	:	:	
			1	0	0	0	1	+14dB	
			1	0	0	0	0	+15dB	
	0	0						Equalizer Q 1	
	0	1						2	
	1	0						3	
	1	1						<u>4</u>	
0								Pause-Detector Source Rear Input-Selector	
1								<u>Front Input-Selector</u>	

Table 22. Equalizer High-Filter (15)

MSB							LSB		FUNCTION
D7	D6	D5	D4	D3	D2	D1	D0		
			0	0	0	0	0	Gain / Attenuation -15dB	
			0	0	0	0	1	-14dB	
			:	:	:	:	:	:	
			0	1	1	1	0	-1dB	
			0	1	1	1	1	0dB	
			1	1	1	1	1	0dB	
			1	1	1	1	0	<u>+1dB</u>	
			:	:	:	:	:	:	
			1	0	0	0	1	+14dB	
			1	0	0	0	0	+15dB	
	0	0						Equalizer Q 1	
	0	1						2	
	1	0						3	
	1	1						<u>4</u>	
0								Switch Qual.-Detector Noise Content Off	
1								<u>On</u>	

Table 23. Speaker, Subwoofer and Mixer Level-Control (16-20)

The programming of all Speaker-, Subwoofer and Mixing Level-Controls are the same.

MSB							LSB		ATTENUATION
D ₇	D ₆	D ₅	D ₄	D ₃	D ₂	D ₁	D ₀		
1	0	0	0	1	1	1	1	+15 dB	
:	:	:	:	:	:	:	:	:	
1	0	0	0	0	0	0	1	+1 dB	
1	0	0	0	0	0	0	0	0 dB	
0	0	0	0	0	0	0	0	0 dB	
0	0	0	0	0	0	0	1	-1 dB	
:	:	:	:	:	:	:	:	:	
0	0	0	0	1	1	1	1	-15 dB	
0	0	0	1	0	0	0	0	-16 dB	
:	:	:	:	:	:	:	:	:	
0	1	0	0	1	1	1	0	-78 dB	
0	1	0	0	1	1	1	1	-79 dB	
x	1	1	x	x	x	x	x	<u>Mute</u>	

Table 24. Testing Audioprocessor (21)

MSB							LSB		FUNCTION
D ₇	D ₆	D ₅	D ₄	D ₃	D ₂	D ₁	D ₀		
								Audioprocessor Testmode <u>off</u> on	
				0 0 0 0 1 1 1 1	0 0 1 1 0 1 1 1	0 1 1 0 0 1 0 1		Test-Multiplexer Compander Log-Amp. Output Compander Low-Pass Output Compander DAC Output 200kHz Oscillator not allowed AM NB Mute NB-Hold <u>internal Reference</u>	
			0 1					Compander Testmode off <u>on</u>	
		0 1						Clock external <u>internal</u>	
	0 1							AZ Function off <u>on</u>	
0 1								SC-Clock Fast Mode <u>Normal Mode</u>	

Note : This byte is used for testing or evaluation purposes only and must not set to other values than "11101110" in the application!

Table 25. Stereodecoder (22)

MSB							LSB	FUNCTION
D7	D6	D5	D4	D3	D2	D1	D0	
							0 1	STD Unmuted STD Muted
					0 0 1 1	0 1 0 1		IN-Gain 11dB IN-Gain 8.5dB IN-Gain 6dB IN-Gain 3.5dB
				0 1				Input AM-Pin Input MPX-Pin
			0 1					Forced MONO MONO/STEREO switch automatically
		0 1						Pilot Threshold HIGH Pilot Threshold LOW
0 0 1 1	0 1 0 1							Deemphasis 50µs (37.5µs ¹) Deemphasis 62.5µs (46.9µs ¹) Deemphasis 75µs (56.3µs ¹) Deemphasis 100µs (75µs ¹)

Note: 1. If Deemphasis-Shift enabled (Subaddr.26/Bit7 = 0)

Table 26. Noiseblanker I (23)

MSB							LSB	FUNCTION
D7	D6	D5	D4	D3	D2	D1	D0	
							0 1	Noiseblanker off Noiseblanker on
				0 0 0 0 1 1 1 1	0 0 1 1 0 0 1 1	0 1 0 0 1 1 0 1		Low Threshold 65mV Low Threshold 60mV Low Threshold 55mV Low Threshold 50mV Low Threshold 45mV Low Threshold 40mV Low Threshold 35mV Low Threshold 30mV
		0 0 1 1	0 1 0 1					Noise Controlled Threshold 320mV Noise Controlled Threshold 260mV Noise Controlled Threshold 200mV Noise Controlled Threshold 140mV
0 0 1 1	0 1 0 1							Overdeviation Adjust 2.8V Overdeviation Adjust 2.0V Overdeviation Adjust 1.2V Overdeviation Detector OFF

Table 27. Noiseblanker II (24)

MSB							LSB	FUNCTION
D7	D6	D5	D4	D3	D2	D1	D0	
							0 1	PEAK charge current low high
					0 0 1 1	0 1 0 1		Fieldstrength adjust 2.3V 1.8V 1.3V OFF
			0 0 1 1	0 1 0 1				Blank Time FM / AM 38µs / 1.2ms 25.5µs / 800µs 32µs / 1.0s <u>22µs / 640µs</u>
	0 0 1 1	0 1 0 1						Noise Rectifier Discharge Resistor R = infinite R _{DC} = 56k R _{DC} = 33k <u>R_{DC} = 18k</u>
0 1								Strong Multipath influence on PEAK 18k off on (18k discharge if $V_{MPout} < 2.5V$)

Table 28. AM / FM-Noiseblanker (25)

MSB							LSB	FUNCTION
D7	D6	D5	D4	D3	D2	D1	D0	
							0 1	Stereodecoder Mode FM AM
				0 0 0 0 1 1 1 1	0 0 1 1 0 1 1	0 1 1 0 1 0 1		AM Rectifier Gain 6dB 8dB 10dB 12dB 14dB 16dB 18dB <u>20dB</u>
		0 0 1 1	0 1 0 1					Rectifier Cut-Off Frequency 14.0kHz 18.5kHz 28.0kHz <u>56.0kHz</u>
	0 1							Overdeviation Time Constant on <u>off</u>
0 1								AM Blank-Mode High-Ohmic Mute <u>Sample&Hold</u>

Table 29. High-Cut (26)

MSB							LSB	FUNCTION
D7	D6	D5	D4	D3	D2	D1	D0	
							0 1	High-Cut off on
					0 0 1 1	0 1 0 1		max. High-Cut 2dB 5dB 7dB 10dB
			0 0 1 1	0 1 0 1				VHCH to be at 42% REF5V 50% REF5V 58% REF5V 66% REF5V
	0 0 1 1	0 1 0 1						VHCL to be at 16.7% VHCH 22.2% VHCH 27.8% VHCH 33.3% VHCH
0 1								Deemphasis Shift On Off

Table 30. Fieldstrength Control (27)

MSB							LSB	FUNCTION	
D7	D6	D5	D4	D3	D2	D1	D0		
				0 0 0 0 0 0 0 0 1 1 1 1 1 1 1	0 0 0 0 1 1 1 1 0 0 0 0 1 1 1	0 0 1 1 0 1 0 1 0 1 0 0 1 0 1	0 1 0 1 0 1 0 1 0 1 1 0 1 1	VSBL to be at 20.0% REF5V 23.3% REF5V 26.6% REF5V 30.0% REF5V 33.3% REF5V 36.6% REF5V 40.0% REF5V 43.3% REF5V 46.6% REF5V 50.0% REF5V 53.3% REF5V 56.6% REF5V 60.0% REF5V 63.3% REF5V 66.6% REF5V 70.0% REF5V	
		0 0 1 1	0 1 0 1						Quality Detector Coefficient a=0.7 a=0.85 a=1.0 a=1.15
0 0 1 1	0 1 0 1								HCC-Level-Shift (only Level through MPD) 0.0V 500mV 1.0 V 1.5 V

Table 31. Multipath Detector (28)

MSB							LSB	FUNCTION
D ₇	D ₆	D ₅	D ₄	D ₃	D ₂	D ₁	D ₀	
							0 1	Fast Load on off
					0 0 1 1	0 1 0 1		Bandpass Gain 6dB 12dB 16dB 18dB
			0 0 1 1	0 1 0 1				Rectifier Gain Gain = 7.6dB Gain = 4.6dB Gain = 0dB disabled
		0 1						Charge Current at MP-Out 0.25µA 0.50µA
	0 1							Multipath on High-Cut Decay-Time 2ms 10ms
0 1								Multipath influence on PEAK Discharge off -1V/ms

Table 32. Stereodecoder Adjustment (29)

MSB							LSB	FUNCTION
D ₇	D ₆	D ₅	D ₄	D ₃	D ₂	D ₁	D ₀	
0 0 0 : 0 : : 0					0 0 0 : 1 : : 1	0 0 1 : 0 : : 1	0 1 0 : 0 : : 1	Roll-Off Compensation not allowed 7.2% 9.4% : 13.7% : : 20.2%
1 1 1 : 1 : 1					0 0 0 : 1 : : 1	0 0 1 : 0 : : 1	0 1 0 : 0 : : 1	not allowed 19.6% 21.5% : 25.3% : : 31.0%
	0 0 0 : 1	0 0 0 : 1	0 0 1 : 1	0 1 0 : 1				LEVEL Gain 0dB 0.4dB 0.8dB : 6dB

Table 33. Stereodecoder Configuration (30)

MSB							LSB		FUNCTION
D7	D6	D5	D4	D3	D2	D1	D0		
							0 1	Multipath Influence on High-Cut On Off	
						0 1		Multipath Influence on Stereo-Blend On Off	
					0 1	1 x	1 x	Level-Input over Multipath-Detector ¹ On Off	
				0 1				Dual MPX Mode On Off	
			0 1					Weak-Signal-Mute on off	
		0 1						WSMute Threshold 0.3 V 0.5V	
0 0 1 1	0 1 0 1							WS-Mute-Depth -20 dB -24 dB -28 dB -32 dB	

Note: 1. Using the Multipath Time-Constants for Stereo-Bland and High-Cut

Table 34. Testing Stereodecoder(31)

MSB							LSB		FUNCTION
D7	D6	D5	D4	D3	D2	D1	D0		
							0 1	Main Testmode off on	
						0 1		Stereodecoder Testmode off on	
		0 0 0 0 0 0 0 0 1 1 1 1 1 1 1	0 0 0 0 1 1 1 0 0 0 1 1 1 1	0 0 1 1 0 1 1 0 0 1 1 0 1 1	0 1 0 0 0 1 0 0 1 0 1 0 1 1			Testsignals F228 NB threshold Level for Stereo-Blend Pilot magnitude VHCCL Pilot threshold VHCCH REF5V HOLDN NB Peak AM-Rectifier VCOCON; VCO Control Voltage VSBL Pilot threshold Level for High-Cut REF5V	
	0 1							Audioprocessor Oscillator Off On	
0 1								Disable Noiseblanker @ FS > 2.5V On Off	

Note : This byte is used for testing or evaluation purposes only and must not set to other values than "11111100" in the application

DIM.	mm			inch		
	MIN.	TYP.	MAX.	MIN.	TYP.	MAX.
A			1.60			0.063
A1	0.05		0.15	0.002		0.006
A2	1.35	1.40	1.45	0.053	0.055	0.057
B	0.30	0.37	0.45	0.012	0.014	0.018
C	0.09		0.20	0.004		0.008
D		12.00			0.472	
D1		10.00			0.394	
D3		8.00			0.315	
e		0.80			0.031	
E		12.00			0.472	
E1		10.00			0.394	
E3		8.00			0.315	
L	0.45	0.60	0.75	0.018	0.024	0.030
L1		1.00			0.039	
K	0°(min.), 3.5°(typ.), 7°(max.)					

OUTLINE AND MECHANICAL DATA

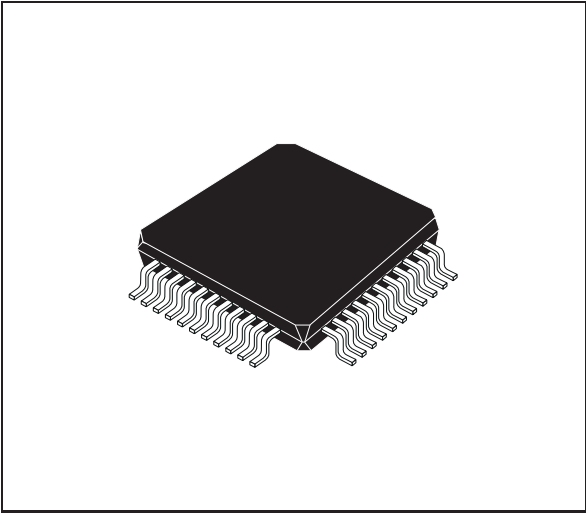

TQFP44 (10 x 10)

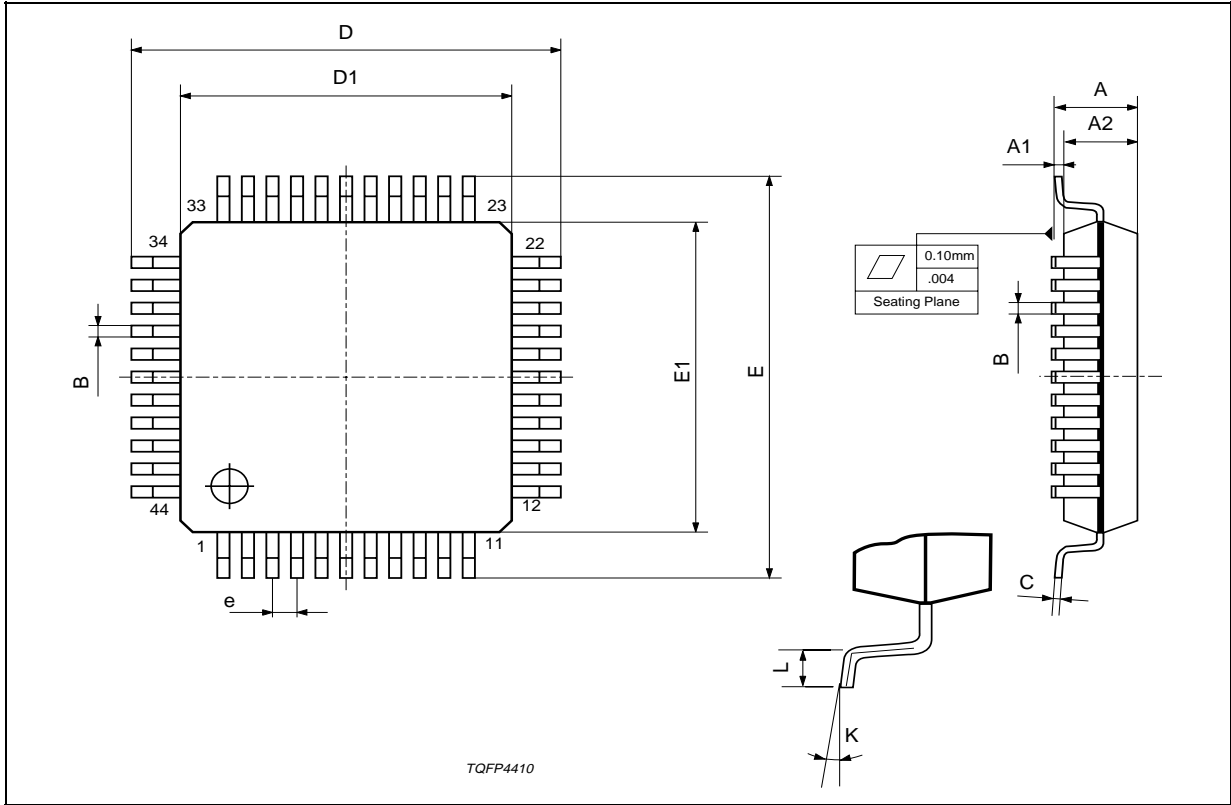

Information furnished is believed to be accurate and reliable. However, STMicroelectronics assumes no responsibility for the consequences of use of such information nor for any infringement of patents or other rights of third parties which may result from its use. No license is granted by implication or otherwise under any patent or patent rights of STMicroelectronics. Specifications mentioned in this publication are subject to change without notice. This publication supersedes and replaces all information previously supplied. STMicroelectronics products are not authorized for use as critical components in life support devices or systems without express written approval of STMicroelectronics.

The ST logo is a registered trademark of STMicroelectronics
© 2001 STMicroelectronics - All Rights Reserved

STMicroelectronics GROUP OF COMPANIES
Australia - Brazil - Canada - China - Finland - France - Germany - Hong Kong - India - Israel - Italy - Japan -Malaysia - Malta - Morocco -
Singapore - Spain - Sweden - Switzerland - United Kingdom - United States.
<http://www.st.com>