

NCP3712ASNT1

Over Voltage Protected High Side Switch

This switch is primarily intended to protect loads from transients by isolating the load from the transient energy rather than absorbing it.

Features

- Capable of Switching Loads of up to 200 mA without External Rboost
- Switch Shuts Off in Response to an Over Voltage Input Transient
- Features Active Turn Off for Fast Input Transient Protection
- Flexible Over Voltage Protection Threshold Set with External Zener
- Automatic Recovery after Transient Decays Below Threshold
- Withstands Input Transients up to 105 V Peak
- Guaranteed Off State with $\overline{\text{Enbl}}$ Input
- ESD Resistant in Accordance with the 2000 V Human Body Model
- Extremely Low Saturation Voltage

Applications Include:

- High Voltage Transient Isolation
- Power Switching to Electronic Modules
- DC Power Distribution in Line Operated Equipment
- Buffering Sensitive Circuits from Poorly Regulated Power Supplies
- Pre-conditioning of Voltage Regulator Input Voltage

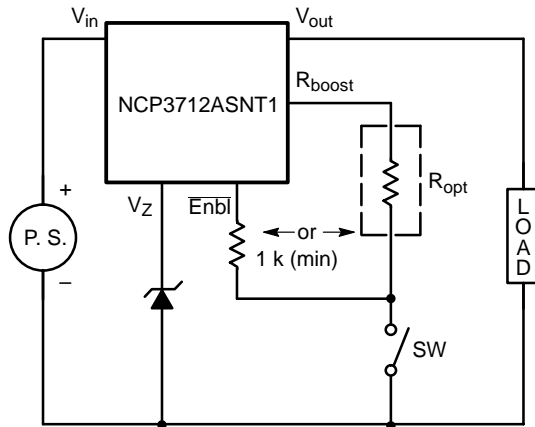

Figure 1. Typical Application Circuit



ON Semiconductor™

<http://onsemi.com>

MARKING DIAGRAM



TSOP-6
(SOT23-6, SC59-6)
CASE 318G

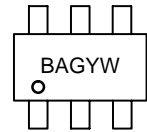

BAG = Specific Device Code
Y = Year
W = Work Week

INTERNAL CIRCUIT DIAGRAM/ PIN CONFIGURATION

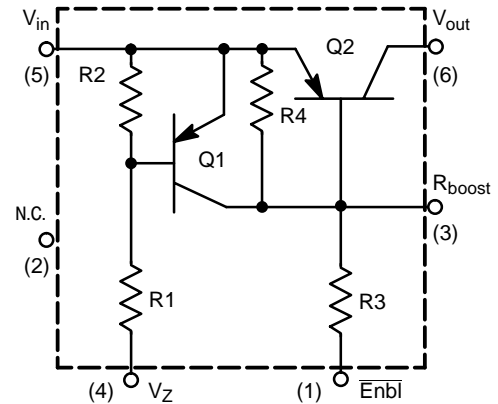

ORDERING INFORMATION

Device	Package	Shipping
NCP3712ASNT1	TSOP-6 (SOT23-6, SC59-6)	3000 Units on 7" Reel

NCP3712ASNT1

MAXIMUM RATINGS* (T_J = 25°C unless otherwise noted) (Note 1)

Rating	Symbol	Value	Unit
Input-to-Output Voltage	V _{io}	105	V
Reverse Input-to-Vz. Voltage	V _{in(rev)}	-9.0	V
Reverse Input-to-Rboost Voltage	V _{in(rev)}	-5.0	V
Output Load Current – Continuous	I _{load}	-300	mA
Enbl Input Current – Continuous	I _{enbl}	5.0	mA
Vz Input Current – Continuous	I _z	3.0	mA
Rboost Input Current – Continuous	I _{boost}	10	mA
Junction Temperature	T _J	125	°C
Operating Ambient Temperature Range	T _A	-40 to +85	°C
Storage Temperature Range	T _{stg}	-65 to +150	°C
Device Power Dissipation (Minimum Footprint)	P _D	300	mW
Derate Above 25°C	–	2.4	mW/°C
Latch-up Performance:	I _{Latch-up}		mA
Positive		200	
Negative		200	

*Maximum Ratings are those values beyond which damage to the device may occur.

- This device contains ESD protection and exceeds the following tests:
Human Body Model 1500 V per MIL-STD-883, Method 3015.
Machine Model Method 150 V.

NCP3712ASNT1

ELECTRICAL CHARACTERISTICS ($V_{in} = 12.5 V_{DC}$ Ref to Gnd, $T_A = 25^\circ C$ unless otherwise noted.)

Characteristic	Symbol	Min	Typ	Max	Unit
----------------	--------	-----	-----	-----	------

OFF CHARACTERISTICS

Input–Output Breakdown Voltage (@ $I_{out} = 200 \mu A$)	$V_{(BRio)}$	105	–	–	Vdc
Output Reverse Breakdown Voltage (@ $I_{out} = -1.0 mA$ Pulse)	$V_{(-BRout)}$	–	-0.7	–	Vdc
Output Leakage Current ($V_{in} = V_{enbl} = 30 V$, $T_A = 25^\circ C$)	$I_{load(off)}$	–	–	-100	μA_{dc}
Guaranteed “Off” State “ENBL NOT” Voltage ($I_O \leq 100 \mu A$)	$V_{enbl(off)}$	13	–	–	Vdc
Required “Off” State I_z Current ($R_{load} = 100 \Omega$)	$I_{z(off)}$	150	–	–	μA_{dc}
$V_{in(off)}$ ($V_z = 16 V$, $I_{load} = 100 mA$, $R_{enbl} = 1500 \Omega$)	V_{off}	15.5	–	18.7	Vdc

ON CHARACTERISTICS

Input–Output On Voltage ($I_O = 100 mA$, $I_{enbl} = -3.0 mA$)	$V_{io(on)}$	–	0.2	0.5	Vdc
Output Load Current — Continuous ($I_{enbl} = -3.0 mA$, $V_{io(on)} = 0.5 V_{dc}$) ($I_{boost} = -9.0 mA$, $V_{io(on)} = 0.5 V_{dc}$) ($I_{boost} = -9.0 mA$, $V_{io(on)} = 0.6 V_{dc}$)	$I_{o(on)}$	–	–	-200 -200 -300	$m A_{dc}$
$V_{in(on)}$ ($V_z = 16 V$, $I_{load} = 100 mA$, $R_{enbl} = 1500 \Omega$)	V_{on}	8.5	–	10.5	Vdc
“ENBL NOT” Input Current ($I_O = 100 mA$, $V_{io(on)} = 0.35 V_{dc}$, $R_{enbl} = 1500 \Omega$)	I_{enbl}	–	–	-1.0	$m A_{dc}$

SWITCHING CHARACTERISTICS

Characteristic	Symbol	Min	Typ	Max	Units
Propagation Delay Time: Hi to Lo Prop Delay; Fig. 3 ($V_{in} = V_{enbl} = 13.5 V$) Lo to Hi Prop Delay; Fig. 3 ($V_{in} = 13.5 V$, $V_{enbl} = 0 V$)	t_{PHL} t_{PLH}	–	1.5 1.5	–	μS
Transition Times: Fall Time; Fig. 4 ($V_{in} = V_{enbl} = 13.5 V$) Rise Time; Fig. 4 ($V_{in} = V_{enbl} = 0 V$)	t_f t_r	–	75 400	–	$n S$

INTERNAL RESISTORS

Input Leakage Resistor	R2	7.0	10	13	$k\Omega$
Input Resistor	R1	3.3	4.7	6.1	$k\Omega$
Output Leakage Resistor	R4	1.4	2.4	3.2	$k\Omega$
Enable Input Resistor	R3	1.4	2.4	3.2	$k\Omega$

NCP3712ASNT1

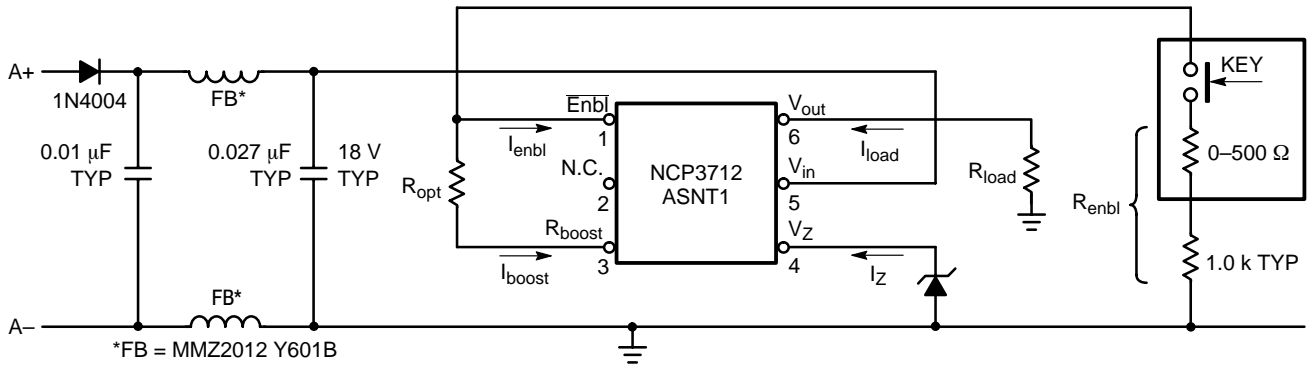

Figure 2. Typical Applications Circuit for Load Dump Transient Protection

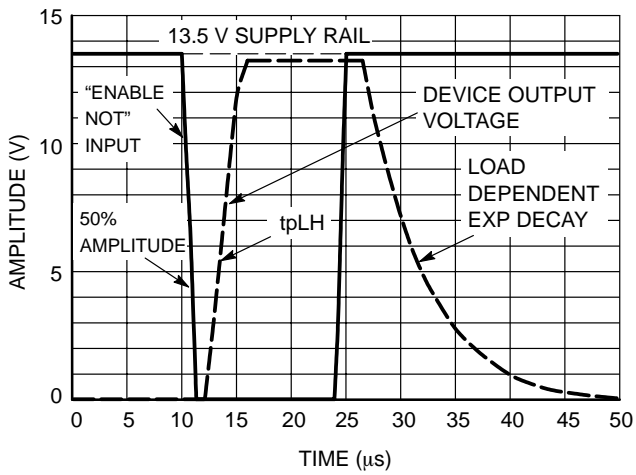

Figure 3. Enable NOT Switching Waveforms

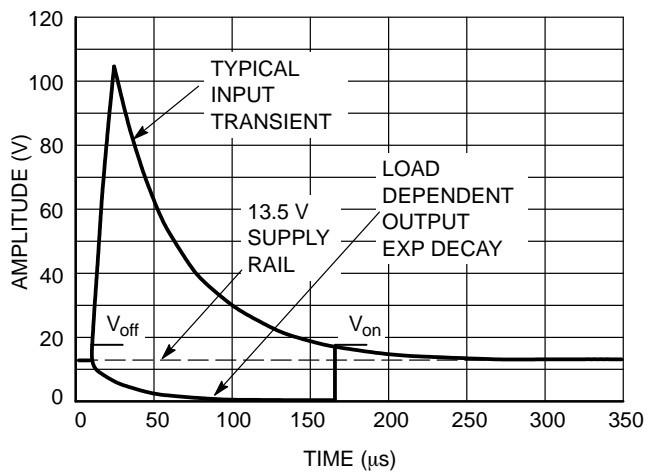

Figure 4. Load Dump Waveforms

INFORMATION FOR USING THE TSOP-6 SURFACE MOUNT PACKAGE

MINIMUM RECOMMENDED FOOTPRINT FOR SURFACE MOUNTED APPLICATIONS

Surface mount board layout is a critical portion of the total design. The footprint for the semiconductor packages must be the correct size to insure proper solder connection

interface between the board and the package. With the correct pad geometry, the packages will self align when subjected to a solder reflow process.

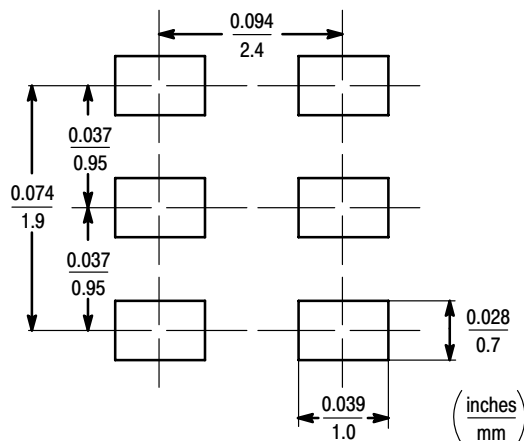

TSOP-6
(SOT23-6, SC59-6)

TSOP-6 POWER DISSIPATION

The power dissipation of the TSOP-6 is a function of the drain pad size. This can vary from the minimum pad size for soldering to a pad size given for maximum power dissipation. Power dissipation for a surface mount device is determined by $T_{J(max)}$, the maximum rated junction temperature of the die, $R_{\theta JA}$, the thermal resistance from the device junction to ambient, and the operating temperature, T_A . Using the values provided on the data sheet for the TSOP-6 package, P_D can be calculated as follows:

$$P_D = \frac{T_{J(max)} - T_A}{R_{\theta JA}}$$

The values for the equation are found in the maximum ratings table on the data sheet. Substituting these values into the equation for an ambient temperature T_A of 25°C, one can calculate the power dissipation of the device which in this case is 950 milliwatts.

$$P_D = \frac{150^\circ\text{C} - 25^\circ\text{C}}{132^\circ\text{C/W}} = 950 \text{ milliwatts}$$

The 132°C/W for the TSOP-6 package assumes the use of the recommended footprint on a glass epoxy printed circuit board to achieve a power dissipation of 950 milliwatts. There are other alternatives to achieving higher power dissipation from the TSOP-6 package. Another alternative would be to use a ceramic substrate or an aluminum core board such as Thermal Clad™. Using a board material such as Thermal Clad, an aluminum core board, the power dissipation can be doubled using the same footprint.

SOLDERING PRECAUTIONS

The melting temperature of solder is higher than the rated temperature of the device. When the entire device is heated to a high temperature, failure to complete soldering within a short time could result in device failure. Therefore, the following items should always be observed in order to minimize the thermal stress to which the devices are subjected.

- Always preheat the device.
- The delta temperature between the preheat and soldering should be 100°C or less.*
- When preheating and soldering, the temperature of the leads and the case must not exceed the maximum temperature ratings as shown on the data sheet. When using infrared heating with the reflow soldering method, the difference shall be a maximum of 10°C.
- The soldering temperature and time shall not exceed 260°C for more than 10 seconds.
- When shifting from preheating to soldering, the maximum temperature gradient shall be 5°C or less.
- After soldering has been completed, the device should be allowed to cool naturally for at least three minutes. Gradual cooling should be used as the use of forced cooling will increase the temperature gradient and result in latent failure due to mechanical stress.
- Mechanical stress or shock should not be applied during cooling.

* * Soldering a device without preheating can cause excessive thermal shock and stress which can result in damage to the device.

NCP3712ASNT1

PACKAGE DIMENSIONS

TSOP-6
CASE 318G-02
ISSUE H

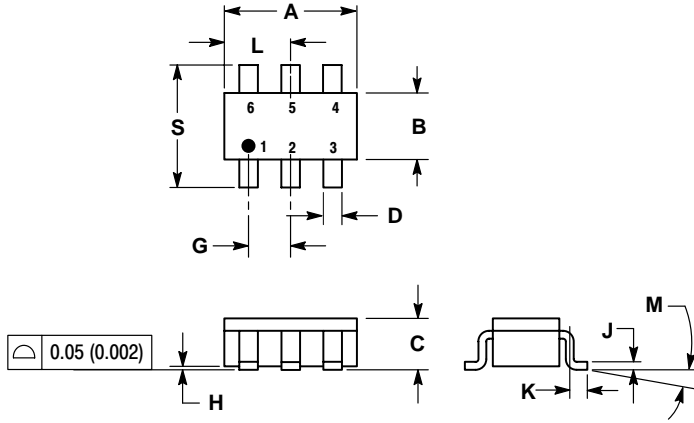

NOTES:

1. DIMENSIONING AND TOLERANCING PER ANSI Y14.5M, 1982.
2. CONTROLLING DIMENSION: MILLIMETER.
3. MAXIMUM LEAD THICKNESS INCLUDES LEAD FINISH THICKNESS. MINIMUM LEAD THICKNESS IS THE MINIMUM THICKNESS OF BASE MATERIAL.

DIM	MILLIMETERS		INCHES	
	MIN	MAX	MIN	MAX
A	2.90	3.10	0.1142	0.1220
B	1.30	1.70	0.0512	0.0669
C	0.90	1.10	0.0354	0.0433
D	0.25	0.50	0.0098	0.0197
G	0.85	1.05	0.0335	0.0413
H	0.013	0.100	0.0005	0.0040
J	0.10	0.26	0.0040	0.0102
K	0.20	0.60	0.0079	0.0236
L	1.25	1.55	0.0493	0.0610
M	0°	10°	0°	10°
S	2.50	3.00	0.0985	0.1181

Notes

Thermal Clad is a registered trademark of the Bergquist Company.

ON Semiconductor and  are trademarks of Semiconductor Components Industries, LLC (SCILLC). SCILLC reserves the right to make changes without further notice to any products herein. SCILLC makes no warranty, representation or guarantee regarding the suitability of its products for any particular purpose, nor does SCILLC assume any liability arising out of the application or use of any product or circuit, and specifically disclaims any and all liability, including without limitation special, consequential or incidental damages. "Typical" parameters which may be provided in SCILLC data sheets and/or specifications can and do vary in different applications and actual performance may vary over time. All operating parameters, including "Typicals" must be validated for each customer application by customer's technical experts. SCILLC does not convey any license under its patent rights nor the rights of others. SCILLC products are not designed, intended, or authorized for use as components in systems intended for surgical implant into the body, or other applications intended to support or sustain life, or for any other application in which the failure of the SCILLC product could create a situation where personal injury or death may occur. Should Buyer purchase or use SCILLC products for any such unintended or unauthorized application, Buyer shall indemnify and hold SCILLC and its officers, employees, subsidiaries, affiliates, and distributors harmless against all claims, costs, damages, and expenses, and reasonable attorney fees arising out of, directly or indirectly, any claim of personal injury or death associated with such unintended or unauthorized use, even if such claim alleges that SCILLC was negligent regarding the design or manufacture of the part. SCILLC is an Equal Opportunity/Affirmative Action Employer.

PUBLICATION ORDERING INFORMATION

Literature Fulfillment:

Literature Distribution Center for ON Semiconductor
P.O. Box 5163, Denver, Colorado 80217 USA
Phone: 303-675-2175 or 800-344-3860 Toll Free USA/Canada
Fax: 303-675-2176 or 800-344-3867 Toll Free USA/Canada
Email: ONlit@hibbertco.com

N. American Technical Support: 800-282-9855 Toll Free USA/Canada

JAPAN: ON Semiconductor, Japan Customer Focus Center
4-32-1 Nishi-Gotanda, Shinagawa-ku, Tokyo, Japan 141-0031
Phone: 81-3-5740-2700
Email: r14525@onsemi.com

ON Semiconductor Website: <http://onsemi.com>

For additional information, please contact your local Sales Representative.