

PNP Silicon Switching Transistors

BSS 80
BSS 82

- High DC current gain
- Low collector-emitter saturation voltage
- Complementary types: BSS 79, BSS 81 (NPN)



Type	Marking	Ordering Code (tape and reel)	Pin Configuration			Package ¹⁾
			1	2	3	
BSS 80 B	CHs	Q62702-S557	B	E	C	SOT-23
BSS 80 C	CJs	Q62702-S492				
BSS 82 B	CLs	Q62702-S560				
BSS 82 C	CMs	Q62702-S482				

Maximum Ratings

Parameter	Symbol	Values		Unit
		BSS 80	BSS 82	
Collector-emitter voltage	V_{CE0}	40	60	V
Collector-base voltage	V_{CB0}	60		
Emitter-base voltage	V_{EB0}	5		
Collector current	I_C	800		mA
Peak collector current	I_{CM}	1		A
Base current	I_B	100		mA
Peak base current	I_{BM}	200		
Total power dissipation, $T_s = 77\text{ °C}$	P_{tot}	330		mW
Junction temperature	T_j	150		°C
Storage temperature range	T_{stg}	- 65 ... + 150		

Thermal Resistance

Junction - ambient ²⁾	$R_{th\ JA}$	≤ 290	K/W
Junction - soldering point	$R_{th\ JS}$	≤ 220	

¹⁾ For detailed information see chapter Package Outlines.

²⁾ Package mounted on epoxy pcb 40 mm × 40 mm × 1.5 mm/6 cm² Cu.

Electrical Characteristics

at $T_A = 25\text{ °C}$, unless otherwise specified.

Parameter	Symbol	Values			Unit
		min.	typ.	max.	

DC characteristics

Collector-emitter breakdown voltage $I_C = 10\text{ mA}$	$V_{(BR)CE0}$	40 60	– –	– –	V
Collector-base breakdown voltage $I_C = 10\text{ }\mu\text{A}$	$V_{(BR)CB0}$	60	–	–	
Emitter-base breakdown voltage $I_E = 10\text{ }\mu\text{A}$	$V_{(BR)EB0}$	5	–	–	
Collector-base cutoff current $V_{CB} = 50\text{ V}$ $V_{CB} = 50\text{ V}, T_A = 150\text{ °C}$	I_{CB0}	– –	– –	10 10	nA μA
Emitter-base cutoff current $V_{EB} = 3\text{ V}$	I_{EB0}	–	–	10	nA
DC current gain $I_C = 100\text{ }\mu\text{A}, V_{CE} = 10\text{ V}$	h_{FE}	BSS 80 B/82 B	40	–	–
		BSS 80 C/82 C	75	–	–
$I_C = 1\text{ mA}, V_{CE} = 10\text{ V}$		BSS 80 B/82 B	40	–	–
		BSS 80 C/82 C	100	–	–
$I_C = 10\text{ mA}, V_{CE} = 10\text{ V}^{1)}$		BSS 80 B/82 B	40	–	–
		BSS 80 C/82 C	100	–	–
$I_C = 150\text{ mA}, V_{CE} = 10\text{ V}^{1)}$		BSS 80 B/82 B	40	–	120
	BSS 80 C/82 C	100	–	300	
$I_C = 500\text{ mA}, V_{CE} = 10\text{ V}^{1)}$	BSS 80 B/82 B	40	–	–	
	BSS 80 C/82 C	50	–	–	
Collector-emitter saturation voltage ¹⁾ $I_C = 150\text{ mA}, I_B = 15\text{ mA}$ $I_C = 500\text{ mA}, I_B = 50\text{ mA}$	V_{CEsat}	– –	– –	0.4 1.6	V
Base-emitter saturation voltage ¹⁾ $I_C = 150\text{ mA}, I_B = 15\text{ mA}$ $I_C = 500\text{ mA}, I_B = 50\text{ mA}$	V_{BEsat}	– –	– –	1.3 2.6	

¹⁾ Pulse test conditions: $t \leq 300\text{ }\mu\text{s}, D = 2\text{ %}$.

Electrical Characteristics

at $T_A = 25\text{ }^\circ\text{C}$, unless otherwise specified.

Parameter	Symbol	Values			Unit
		min.	typ.	max.	

AC characteristics

Transition frequency $I_C = 20\text{ mA}$, $V_{CE} = 20\text{ V}$, $f = 100\text{ MHz}$	f_t	—	250	—	MHz
Open-circuit output capacitance $V_{CB} = 10\text{ V}$, $f = 1\text{ MHz}$	C_{obo}	—	6	—	pF
$V_{CC} = 30\text{ V}$, $I_C = 150\text{ mA}$, $I_{B1} = 150\text{ mA}$					
Delay time	t_d	—	—	10	ns
Rise time	t_r	—	—	40	ns
$V_{CC} = 6\text{ V}$, $I_C = 150\text{ mA}$, $I_{B1} = I_{B2} = 15\text{ mA}$					
Storage time	t_{stg}	—	—	80	ns
Fall time	t_f	—	—	30	ns

Test circuits

Delay and rise time

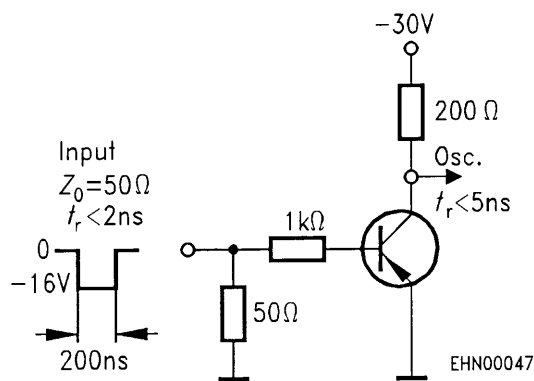

Storage and fall time

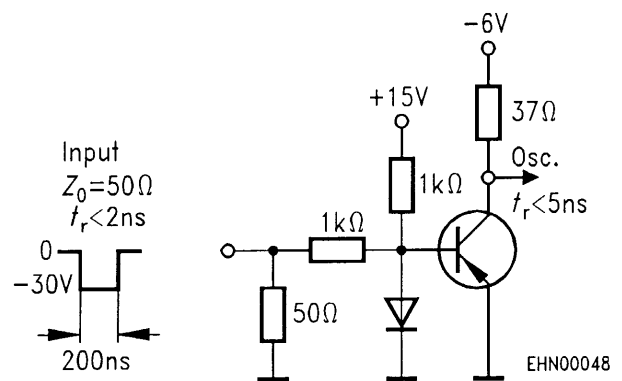

Total power dissipation $P_{tot} = f(T_A^*; T_S)$

* Package mounted on epoxy

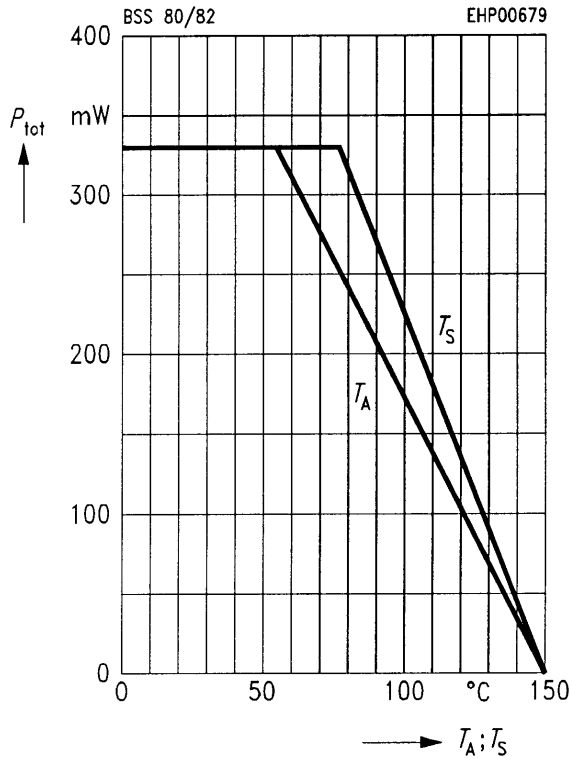

Collector-base capacitance $C_{cb} = f(V_{CB})$

$f = 1 \text{ MHz}$

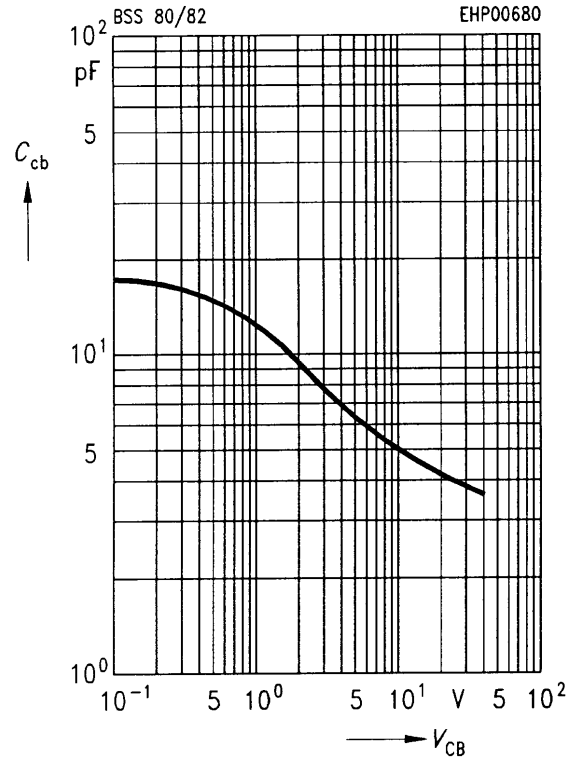

Permissible pulse load $P_{tot \text{ max}}/P_{tot \text{ DC}} = f(t_p)$

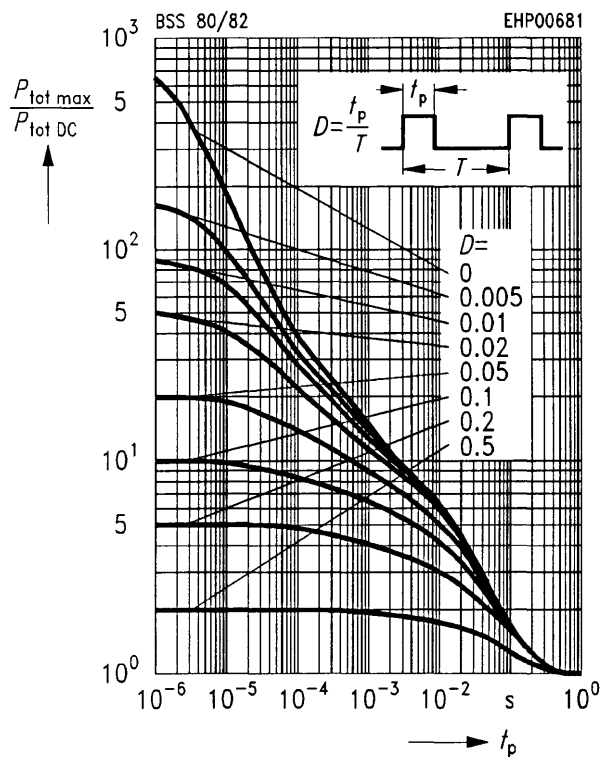

Transition frequency $f_T = f(I_C)$

$V_{CE} = 20 \text{ V}$

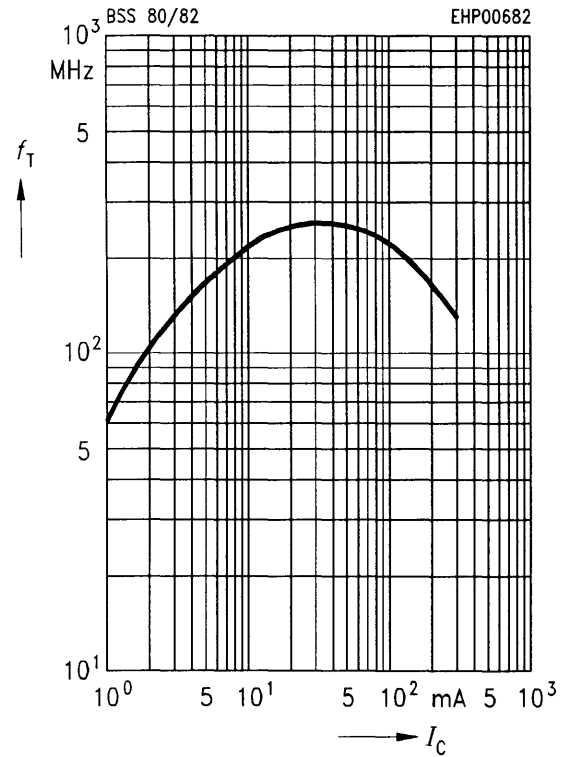

Saturation voltage $I_C = f(V_{BE\ sat}, V_{CE\ sat})$
 $h_{FE} = 10$

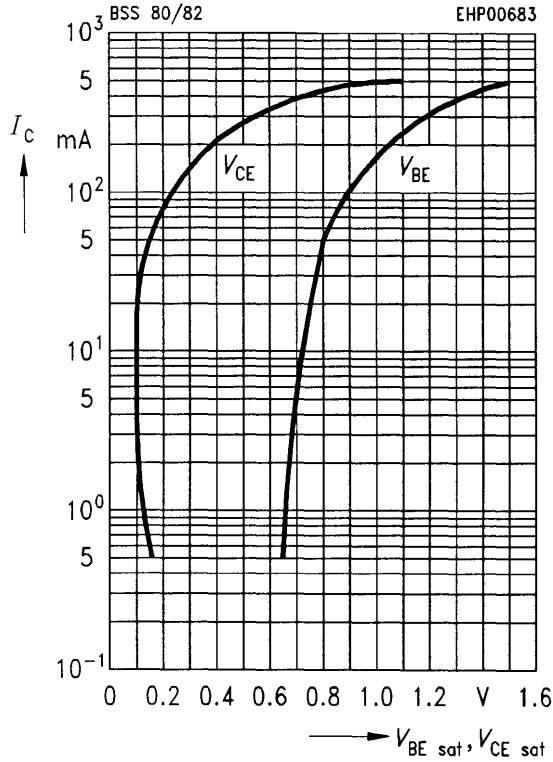

Delay time $t_d = f(I_C)$
Rise time $t_r = f(I_C)$

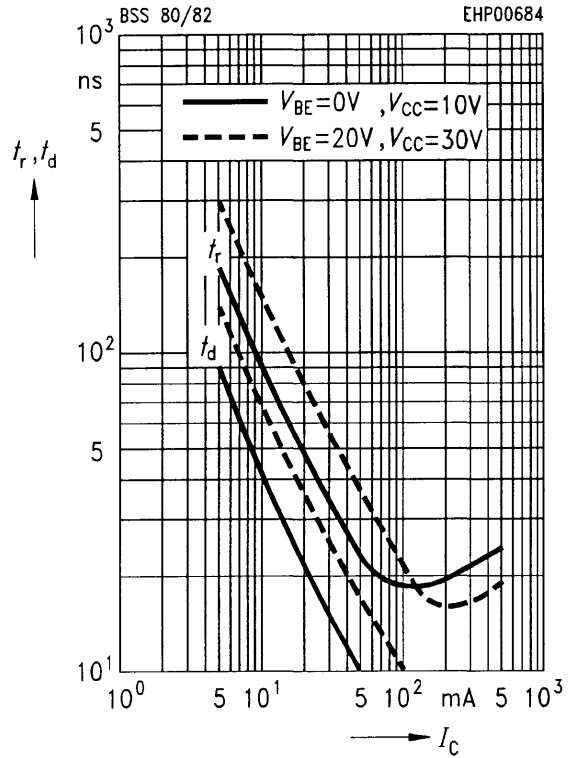

Storage time $t_{stg} = f(I_C)$

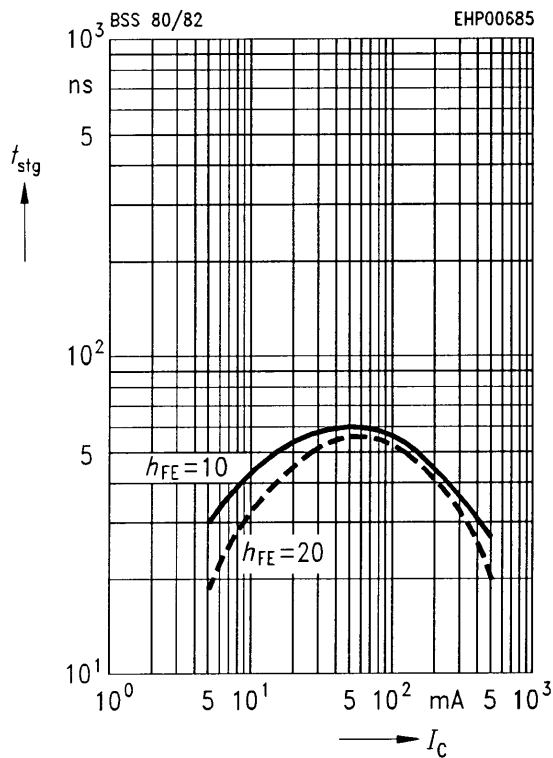

Fall time $t_f = f(I_C)$

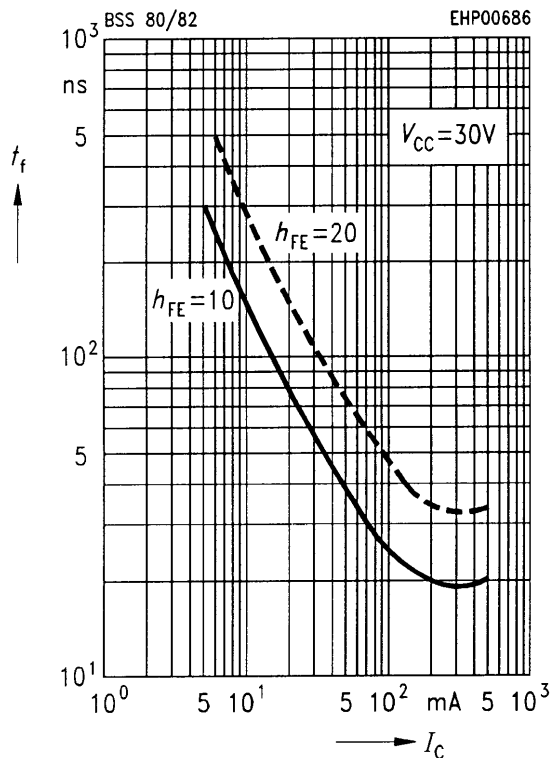

DC current gain $h_{FE} = f(I_C)$

$V_{CE} = 10 \text{ V}$

