

#### Features

- Glass Passivated Die Construction
- Super-Fast Switching
- Low Forward Voltage Drop
- Low Reverse Leakage Current
- High Surge Current Capability
- Plastic Material has UL Flammability Classification 94V-O

#### Mechanical Data

- Case: TO-220AC, Molded Plastic
- Terminals: Plated Leads Solderable per MIL-STD-202, Method 208
- Polarity: See Diagram
- Weight: 2.24 grams (approx.)
- Mounting Position: Any
- **Lead Free: For RoHS / Lead Free Version**

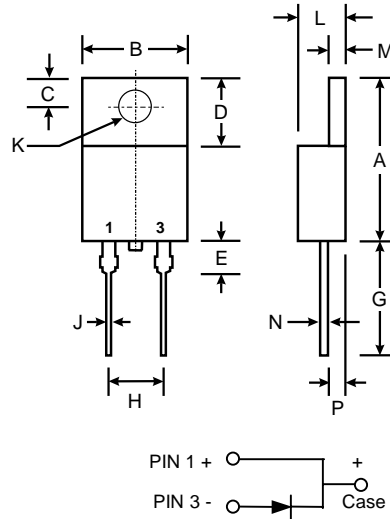

TO-220AC		
Dim	Min	Max
A	14.22	15.88
B	9.57	10.57
C	2.54	3.43
D	5.80	6.80
E	—	6.35
G	12.70	14.73
H	4.88	5.28
J	0.51	1.14
K	3.53 $\varnothing$	4.14 $\varnothing$
L	3.56	4.83
M	1.07	1.47
N	0.30	0.64
P	2.03	2.92
All Dimensions in mm		

#### Maximum Ratings and Electrical Characteristics @ $T_A=25^\circ\text{C}$ unless otherwise specified

Single Phase, half wave, 60Hz, resistive or inductive load.  
For capacitive load, derate current by 20%.

Characteristic	Symbol	ER 1010	ER 1020	ER 1030	ER 1040	ER 1050	ER 1060	Unit
Peak Repetitive Reverse Voltage	$V_{RRM}$							
Working Peak Reverse Voltage	$V_{RWM}$	100	200	300	400	500	600	V
DC Blocking Voltage	$V_R$							
RMS Reverse Voltage	$V_{R(RMS)}$	70	140	210	280	350	420	V
Average Rectified Output Current @ $T_C = 100^\circ\text{C}$	$I_o$	10.0						A
Non-Repetitive Peak Forward Surge Current 8.3ms Single half sine-wave superimposed on rated load (JEDEC Method)	$I_{FSM}$	90						A
Forward Voltage @ $I_f = 10.0\text{A}$	$V_{FM}$	1.0		1.3		1.7		V
Peak Reverse Current @ $T_A = 25^\circ\text{C}$ At Rated DC Blocking Voltage @ $T_A = 100^\circ\text{C}$	$I_{RM}$				2.0 400			$\mu\text{A}$
Reverse Recovery Time (Note 1)	$t_{rr}$				35			nS
Typical Junction Capacitance (Note 2)	$C_j$				200			pF
Operating and Storage Temperature Range	$T_j, T_{STG}$				-55 to +150			$^\circ\text{C}$

Note: 1. Measured with  $I_F = 0.5\text{A}$ ,  $I_R = 1.0\text{A}$ ,  $I_{RR} = 0.25\text{A}$ .  
2. Measured at 1.0 MHz and applied reverse voltage of 4.0V D.C.

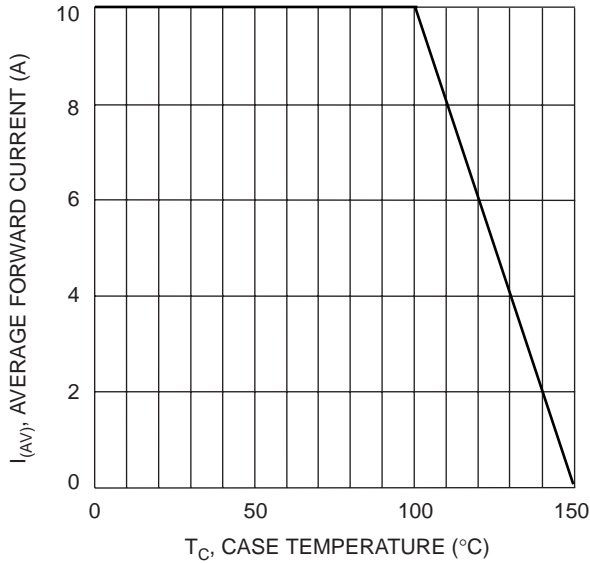

Fig. 1 Forward Current Derating Curve

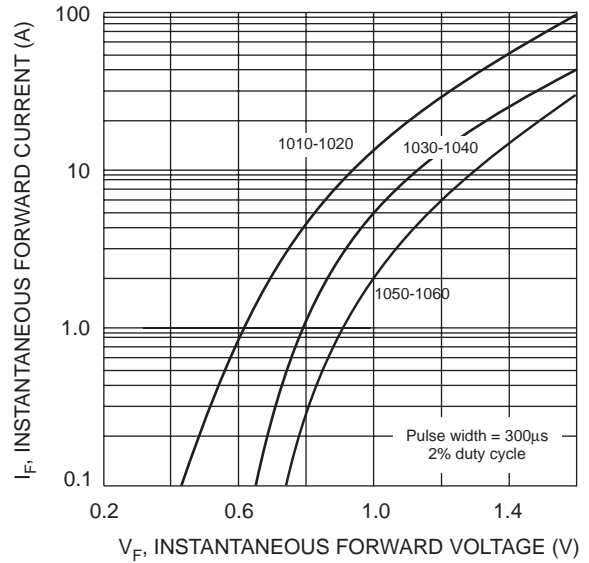

Fig. 2 Typical Forward Characteristics

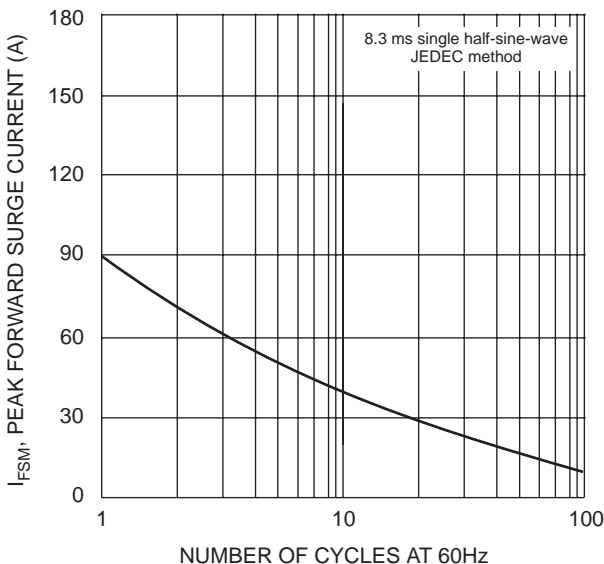

Fig. 3 Max Non-Repetitive Surge Current

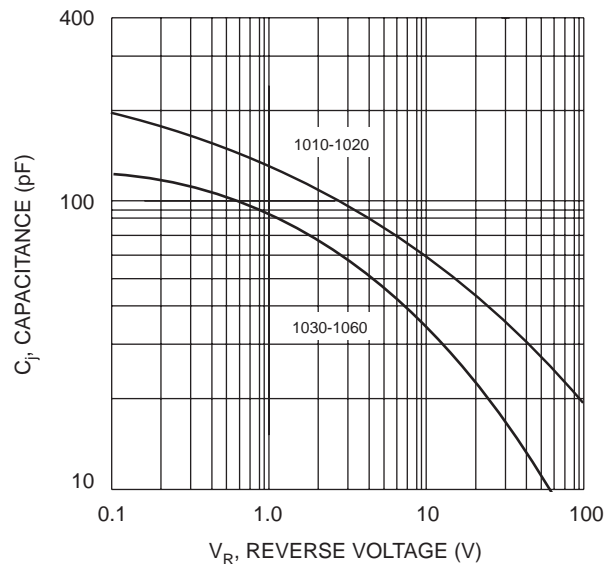
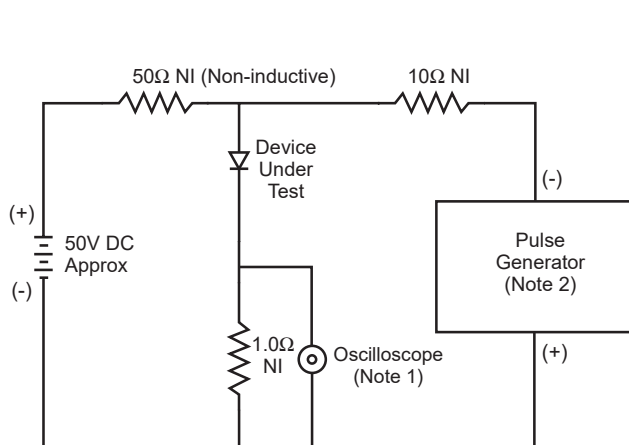
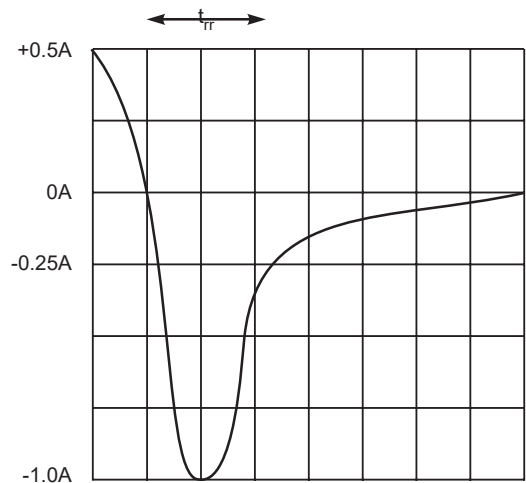

Fig. 4 Typical Junction Capacitance



- Notes:
1. Rise Time = 7.0ns max. Input Impedance = 1.0MΩ, 22pF.
  2. Rise Time = 10ns max. Input Impedance = 50Ω.

Fig. 5 Reverse Recovery Time Characteristic and Test Circuit



Set time base for 5/10ns/cm