

**High Voltage Fast-Switching NPN Power Transistor**

**Features**

- Very High Switching Speed
- Minimum Lot-to-Lot hFE Variation
- Wide Reverse Bias S.O.A

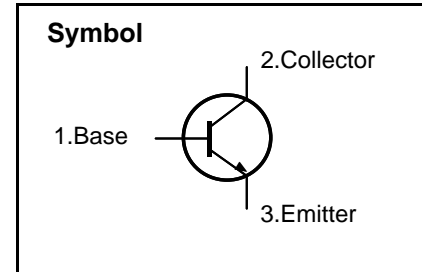

**General Description**

This device is designed for high voltage, high speed switching characteristic required such as lighting system, switching mode power supply.

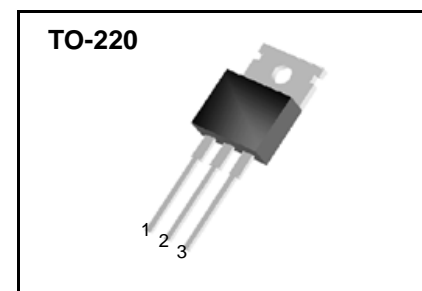

**Absolute Maximum Ratings**

Symbol	Parameter	Value	Units
$V_{CES}$	Collector-Emitter Voltage ( $V_{BE} = 0$ )	700	V
$V_{CEO}$	Collector-Emitter Voltage ( $I_B = 0$ )	400	V
$V_{EBO}$	Emitter-Base Voltage ( $I_C = 0$ )	9.0	V
$I_C$	Collector Current	12.0	A
$I_{CP}$	Collector Pulse Current	24.0	A
$I_B$	Base Current	6.0	A
$I_{BM}$	Base Peak Current ( $t_p < 5$ ms )	12.0	A
$P_C$	Total Dissipation at $T_C = 25$ °C	100	W
$T_{STG}$	Storage Temperature	- 65 ~ 150	°C
$T_J$	Max. Operating Junction Temperature	150	°C

**Thermal Characteristics**

Symbol	Parameter	Value	Units
$R_{\theta JC}$	Thermal Resistance, Junction-to-Case	1.67	°C/W
$R_{\theta JA}$	Thermal Resistance, Junction-to-Ambient	62.5	°C/W

# SBP1300-O

## Electrical Characteristics ( $T_C = 25\text{ }^\circ\text{C}$ unless otherwise noted )

Symbol	Parameter	Condition	Min	Typ	Max	Units
$I_{CEV}$	Collector Cut-off Current ( $V_{BE} = -1.5V$ )	$V_{CE} = 700V$ $V_{CE} = 700V$ $T_C = 100\text{ }^\circ\text{C}$	-	-	1.0 5.0	mA
$V_{CEO(sus)}$	Collector-Emitter Sustaining Voltage ( $I_B = 0$ )	$I_C = 10\text{ mA}$	400	-	-	V
$V_{CE(sat)}$	Collector-Emitter Saturation Voltage	$I_C = 5.0A$ $I_B = 1.0A$ $I_C = 8.0A$ $I_B = 1.6A$ $I_C = 12.0A$ $I_B = 3.0A$	-	-	0.5 0.6 1.0	V
$V_{BE(sat)}$	Base-Emitter Saturation Voltage	$I_C = 5.0A$ $I_B = 1.0A$ $I_C = 8.0A$ $I_B = 1.6A$	-	-	1.2 1.6	V
$h_{FE}^*$	DC Current Gain	$I_C = 5.0A$ $V_{CE} = 5V$ $I_C = 8.0A$ $V_{CE} = 5V$	10 5	-	40 30	
$t_s$ $t_f$	Storage Time Fall Time	$I_C = 8.0A$ $V_{CC} = 125V$ $I_{B1} = 1.6A$ $I_{B2} = -1.6A$ $T_P = 25\mu s$	-		3.0 0.7	$\mu s$

### Notes :

- $h_{FE}$  Sorting : R-Grade(18~26), O-Grade(24~32), Y-Grade(30~40)
- Pulse Test : Pulse width 300 $\mu s$ , Duty cycle 2%



Fig 1. Saturation voltage

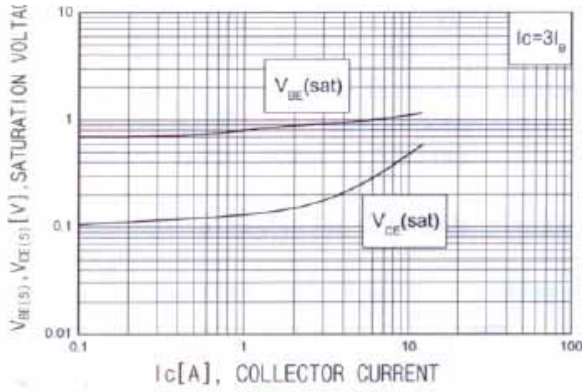

Fig 2. DC Current Gain

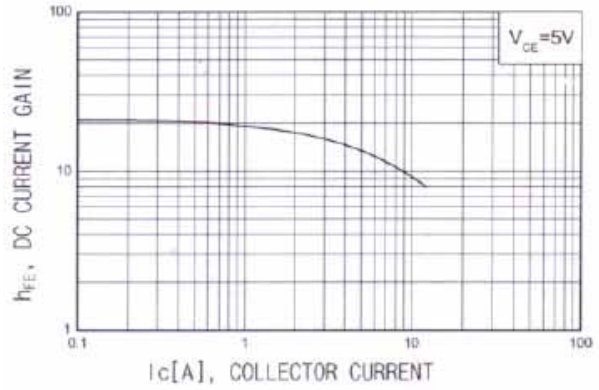

Fig 3. Switching Time

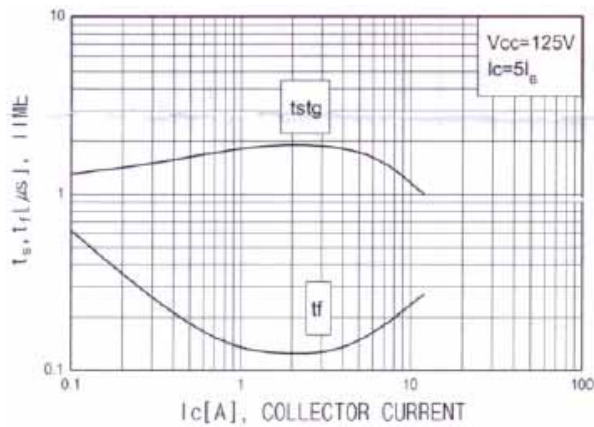

Fig 4. Power Derating

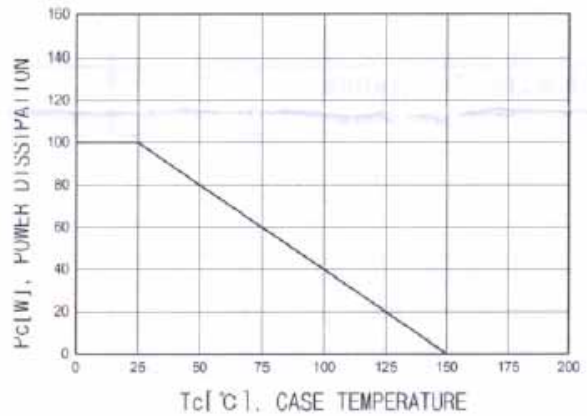

Fig 5. Safe operation area

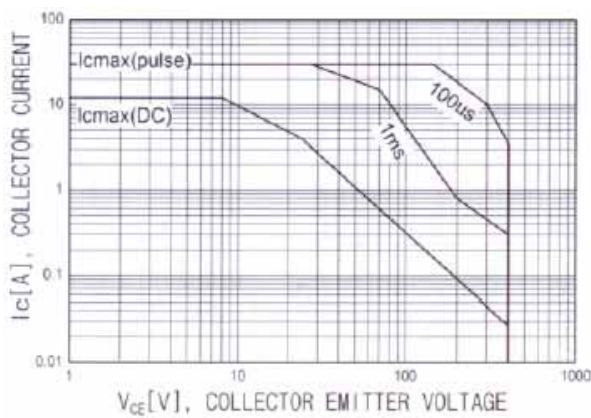
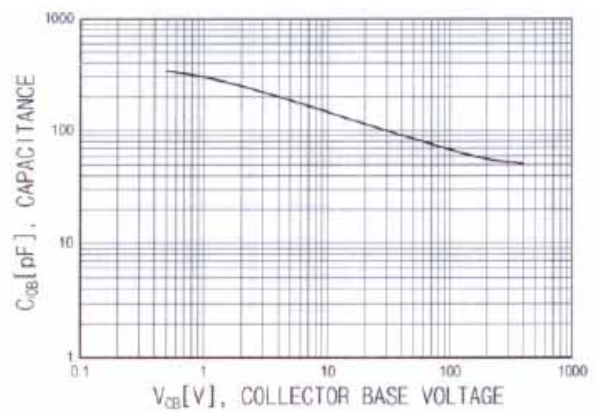
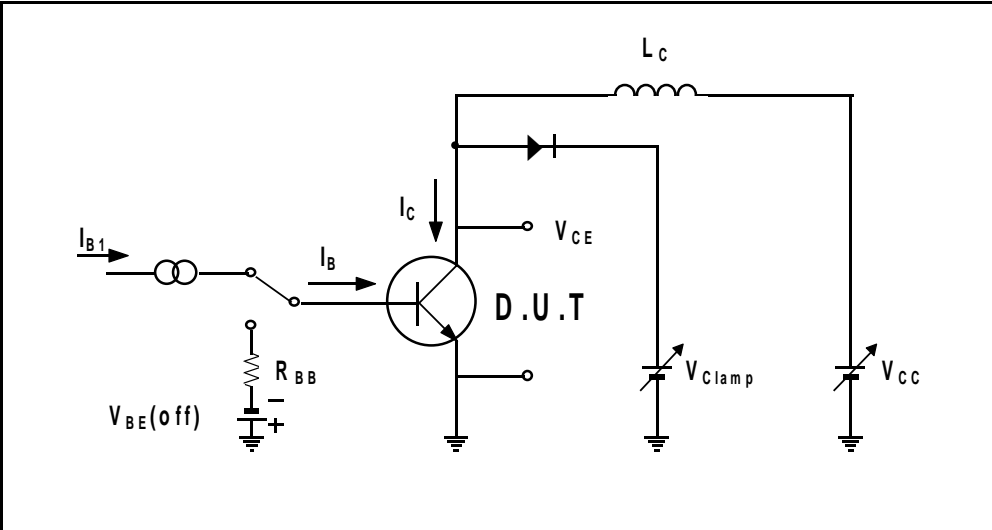

Fig 6. Collect output capacitance



Inductive Load Switching & RBSOA Test Circuit



Resistive Load Switching Test Circuit

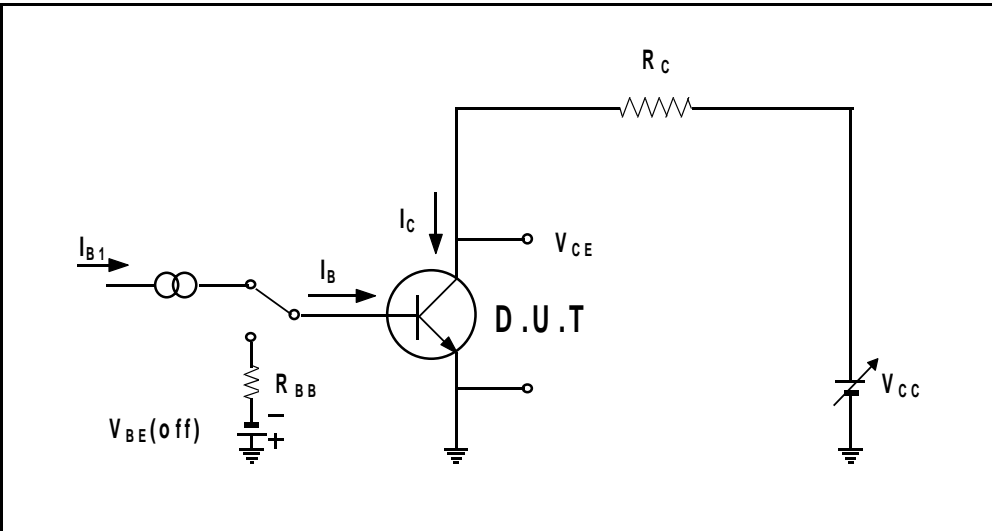

# SBP13009-O

## TO-220 Package Dimension

Dim.	mm			Inch		
	Min.	Typ.	Max.	Min.	Typ.	Max.
A	9.7		10.1	0.382		0.398
B	6.3		6.7	0.248		0.264
C	9.0		9.47	0.354		0.373
D	12.8		13.3	0.504		0.524
E	1.2		1.4	0.047		0.055
F		1.7			0.067	
G		2.5			0.098	
H	3.0		3.4	0.118		0.134
I	1.25		1.4	0.049		0.055
J	2.4		2.7	0.094		0.106
K	5.0		5.15	0.197		0.203
L	2.2		2.6	0.087		0.102
M	1.25		1.55	0.049		0.061
N	0.45		0.6	0.018		0.024
O	0.6		1.0	0.024		0.039
		3.6			0.142	

