

# 12-V to 100-V Input, 0.2-A Output Switching Converter

Check for Samples: [UCC25230](#)

## FEATURES

- Highly Integrated Converter Operating as a Buck, or Isolated Forward-Flyback, Flyback™
- Wide Operating Input Voltage Range from 12 V to 100 V, 105-V Surge.
- Up to 0.2-A Output Current
- 9-V Always Available VDD Output with up to 2-mA Current Capability
- Thermally Enhanced 4-mm x 4-mm SON-8/S-PVSON-N8 (DRM) Package
- Internally Set Fixed 380-kHz Switching Frequency
- Internal 2-ms Duration Soft Start
- Voltage Mode Control with Input Feed Forward Allows Optimal Output Filter Design
- 2% Accuracy Internal 2.5-V Reference
- V<sub>DD</sub> UVLO
- Cycle-by-Cycle Current Limit with Frequency Fold Back for Initial Start up Under High Capacitive Loads
- Input UVLO and OVLO with Input Good Signal
- Integrated 110-V, High and Low-Side Switches

## APPLICATIONS

- High Density Isolated Standby Bias Supplies
- DC-to-DC Converters

## DESCRIPTION

The UCC25230 is a highly integrated PWM converter operating as an isolated forward flyback. It has high-side and low-side power switches integrated and the control circuit with all key converter functions included. The power stage requires only one- or multiple winding coupled inductor and output capacitors for the complete solution. Voltage-mode feed-forward control with external compensation allows optimal output filter selection over wide input voltage range. The UCC25230 has fixed frequency set internally at 380 kHz. It also includes input voltage UVLO and OVLO comparators with hysteresis and input-good, open-collector output signal which can be used to enable PWM controllers.

UCC25230 is available in a thermally enhanced 8-pin SON package with PowerPad™ serving as a ground pin.

Other features include internal soft start and cycle-by-cycle current protection. Measured efficiency of isolated converter over input voltage and output current ranges are shown in [Figure 2](#).

### Isolated Buck Converter

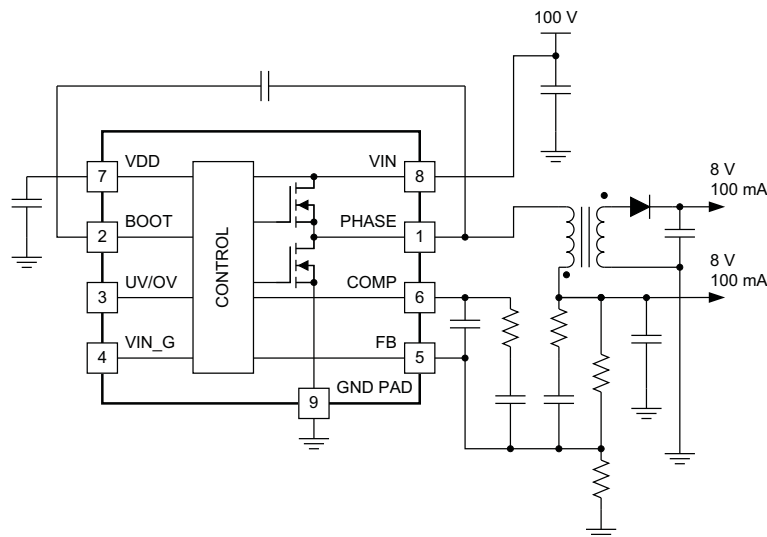

Please be aware that an important notice concerning availability, standard warranty, and use in critical applications of Texas Instruments semiconductor products and disclaimers thereto appears at the end of this data sheet.

PowerPad, Flyback are trademarks of Texas Instruments.



This integrated circuit can be damaged by ESD. Texas Instruments recommends that all integrated circuits be handled with appropriate precautions. Failure to observe proper handling and installation procedures can cause damage.

ESD damage can range from subtle performance degradation to complete device failure. Precision integrated circuits may be more susceptible to damage because very small parametric changes could cause the device not to meet its published specifications.

**ORDERING INFORMATION**

TEMPERATURE RANGE, T <sub>A</sub> = T <sub>J</sub>	PACKAGE	TAPE AND REEL QTY.	PART NUMBER
-40°C to +125°C	SON-8/S-PVSON-N8 (DRM)	250	UCC25230DRMT
		3000	UCC25230DRMR

**ABSOLUTE MAXIMUM RATINGS<sup>(1)(2)</sup>**

over operating free-air temperature range (unless otherwise noted)

		MIN	MAX	UNIT	
Supply voltage range, V <sub>IN</sub>	DC	-0.3	100	V	
	Repetitive surge < 200 ms		105		
Output voltage on PHASE	DC	-0.3	V <sub>IN</sub> + 0.5		
	Repetitive pulse < 100 ns	-2	V <sub>IN</sub> + 1		
Voltage	BOOT with respect to PHASE	-0.3	10		
Voltage	VDD	-0.3	10		
Voltage	FB, UV/OV, COMP	-0.3	VDD		
Voltage	VIN_G	-0.3	5.5		
ESD rating	HBM		2		kV
	CDM		500		V
Sink current	PHASE (peak)		220 (internally limited)	mA	
Source current	PHASE (peak)		-220 (internally limited)		
Operating virtual junction temperature range, T <sub>J</sub>		-40	150	°C	
Operating ambient temperature range, T <sub>A</sub>		-40	125		
Storage temperature, T <sub>STG</sub>		-65	150		
Lead temperature (soldering, 10 sec.)			300		

- (1) Stresses beyond those listed under “absolute maximum ratings” may cause permanent damage to the device. These are stress ratings only, and functional operation of the device at these or any other conditions beyond those indicated under “recommended operating conditions” is not implied. Exposure to absolute-maximum-rated conditions for extended periods may affect device reliability.
- (2) All voltages are with respect to GND. Currents are positive into, negative out of the specified terminal. Consult Packaging Section of the Databook for thermal limitations and considerations of packages.

## THERMAL INFORMATION

THERMAL METRIC <sup>(1)</sup>		UCC25230		UNITS
		DRM		
		8 PINS		
$\theta_{JA}$	Junction-to-ambient thermal resistance <sup>(2)</sup>	33.9		°C/W
$\theta_{JCTop}$	Junction-to-case (top) thermal resistance <sup>(3)</sup>	33.2		
$\theta_{JB}$	Junction-to-board thermal resistance <sup>(4)</sup>	11.4		
$\psi_{JT}$	Junction-to-top characterization parameter <sup>(5)</sup>	0.4		
$\psi_{JB}$	Junction-to-board characterization parameter <sup>(6)</sup>	11.7		
$\theta_{JCbott}$	Junction-to-case (bottom) thermal resistance <sup>(7)</sup>	2.3		

- (1) For more information about traditional and new thermal metrics, see the *IC Package Thermal Metrics* application report, [SPRA953](#).
- (2) The junction-to-ambient thermal resistance under natural convection is obtained in a simulation on a JEDEC-standard, high-K board, as specified in JESD51-7, in an environment described in JESD51-2a.
- (3) The junction-to-case (top) thermal resistance is obtained by simulating a cold plate test on the package top. No specific JEDEC-standard test exists, but a close description can be found in the ANSI SEMI standard G30-88.
- (4) The junction-to-board thermal resistance is obtained by simulating in an environment with a ring cold plate fixture to control the PCB temperature, as described in JESD51-8.
- (5) The junction-to-top characterization parameter,  $\psi_{JT}$ , estimates the junction temperature of a device in a real system and is extracted from the simulation data for obtaining  $\theta_{JA}$ , using a procedure described in JESD51-2a (sections 6 and 7).
- (6) The junction-to-board characterization parameter,  $\psi_{JB}$ , estimates the junction temperature of a device in a real system and is extracted from the simulation data for obtaining  $\theta_{JA}$ , using a procedure described in JESD51-2a (sections 6 and 7).
- (7) The junction-to-case (bottom) thermal resistance is obtained by simulating a cold plate test on the exposed (power) pad. No specific JEDEC standard test exists, but a close description can be found in the ANSI SEMI standard G30-88.

## RECOMMENDED OPERATING CONDITIONS

over operating free-air temperature range (unless otherwise noted)

PARAMETER	MIN	TYP	MAX	UNIT
Supply voltage range, $V_{IN}$	12	48	75, (100 V for 1 ms)	V
Supply bypass capacitor, $C_{VIN}$		1.0		μF
Supply bypass capacitor, $C_{VDD}$	0.1	1.0	2.2	
Operating junction temperature range	-40		+125	°C

## ELECTRICAL CHARACTERISTICS

$V_{IN} = 48\text{ V}$ , 1- $\mu\text{F}$  capacitor from  $V_{IN}$  to GND, 1- $\mu\text{F}$  capacitor from  $V_{DD}$  to GND,  $T_A = T_J = -40^\circ\text{C}$  to  $125^\circ\text{C}$ , (unless otherwise noted)

PARAMETER		TEST CONDITION	MIN	TYP	MAX	UNITS
<b>Supply Currents</b>						
$I_{VIN}$	Quiescent current	$V_{IN} = 5\text{ V}$		0.5	2	mA
$I_{VINO}$	$V_{IN}$ operating current	FB = COMP		4.5	10	
<b>VDD Regulator</b>						
$V_{DD}$	VDD, output voltage		8.46	9	9.54	V
	Line regulation	$17\text{ V} < V_{IN} < 75\text{ V}$		$\pm 5$	$\pm 40$	mV
	Load regulation	$-2\text{ mA} < I_{VDD} < 0\text{ mA}$		$\pm 5$	$\pm 40$	
	VDD current limit (when $V_{DD} = 5.5\text{ V}$ )		-2	-6	-13	mA
<b>Internal Undervoltage Lockout (<math>V_{DD\_UVLO}</math>)</b>						
$V_{DD\_rising}$	VDD rising threshold		7.0	7.5	8	V
$V_{DD\_hyst}$	VDD threshold hysteresis		0.4	0.7	1.1	
$V_{DD\_falling}$	VDD falling threshold		6.3	6.8	7.3	
<b>Undervoltage (external programmable)</b>						
	Falling threshold		0.9	1.0	1.1	V
	lhyst		7	11	18	$\mu\text{A}$
<b>Overvoltage (external programmable)</b>						
	OVLO Rising threshold		4.5	5	5.5	V
	lhyst		-15	-22	-40	$\mu\text{A}$
<b>VIN Power GOOD</b>						
	PG output sink resistance	$I_{PG} = 5\text{ mA to }10\text{ mA}$		50	100	$\Omega$
<b>Oscillator</b>						
f	Oscillator frequency fixed		324	380	445	kHz
$DC_{MIN}$	Minimum duty cycle	FB = 3.0 V			0%	
$DC_{MAX}$	Maximum duty cycle	FB = 2.0 V	85%			
	Frequency variation	$12\text{ V} < V_{IN} < 75\text{ V}$	-15%		15%	

**ELECTRICAL CHARACTERISTICS (continued)**

$V_{IN} = 48\text{ V}$ , 1- $\mu\text{F}$  capacitor from VIN to GND, 1- $\mu\text{F}$  capacitor from VDD to GND,  $T_A = T_J = -40^\circ\text{C}$  to  $125^\circ\text{C}$ , (unless otherwise noted)

PARAMETER		TEST CONDITION	MIN	TYP	MAX	UNITS
<b>Error Amplifier</b>						
	REF voltage	FB = COMP, (T = 25°C)	2.42	2.50	2.58	V
		FB = COMP, (T = -40 to 125°C)	2.40	2.50	2.60	
Avol	Avol open loop voltage gain		40	80		dB
	Input leakage current, FB				±2	μA
I <sub>COM(sink)</sub>	COMP sink current	V <sub>COMP</sub> = 4.5 V	2	4.8	10	mA
I <sub>COM(source)</sub>	COMP source current	V <sub>COMP</sub> = 4.5 V	-2	-6.1	-12	
V <sub>OL</sub>	COMP voltage range	I <sub>COMP</sub> = 100 μA		.4	1.2	V
V <sub>OH</sub>	COMP voltage range	I <sub>COMP</sub> = -100 μA	VDD-1.2	VDD-0.7	VDD	
<b>Soft Start</b>						
	Time for COMP to ramp	FB = COMP	1.75	2.05	2.35	ms
<b>Output</b>						
	R <sub>DS(on)</sub> high	V <sub>IN</sub> = 48 V		6	15	Ω
	R <sub>DS(on)</sub> low	V <sub>IN</sub> = 48 V		5	10	
	Max average current			200		mA
<b>ILIMIT<sup>(1)</sup></b>						
	ILIMIT phase high	V <sub>IN</sub> = 30 V	-600	-400	-220	mA
	Propagation delay, blanking delay plus ILIMIT delay		60	100	140	ns
	ILIMIT phase low	V <sub>IN</sub> = 30 V	220	400	600	mA
	Propagation delay, blanking delay plus ILIMIT delay <sup>(2)</sup>		60	100	140	ns

(1) Continued operation while in ILIM could exceed the maximum power dissipation for the device. For Non-Isolated applications additional external over current protection may be required.

(2) Specified by design, not production tested.

## DEVICE INFORMATION

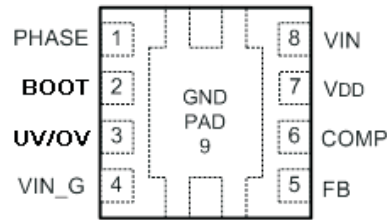

Figure 1.

## TERMINAL FUNCTIONS

TERMINAL		I/O	DESCRIPTION
NAME	NO.		
PHASE	1	O	Phase output of high-side and low-side power FETs.
BOOT	2	I	0.1- $\mu$ F capacitor connected between BOOT and PHASE pins along with the internal diode between BOOT and VDD provides supply voltage to the drive circuit of the upper power FET.
UV/OV	3	I	Input to internal comparators. Internal linear regulator remains functional. A bypass cap of at least 1000 pF is recommended.
VIN_G	4	O	VIN power good. Open drain output, state determined by UV/OV pin.
FB	5	I	Error amplifier inverting input. Connect to output voltage divider with compensation circuit to this pin.
COMP <sup>(1)</sup>	6	O	Output of error amplifier.
VDD	7	O	Output of internal linear regulator. Bypass VDD pin to GND pins close to device package with a high quality, low ESR 1- $\mu$ F ceramic capacitor.
VIN	8	I	Input supply for the power MOSFET switches and internal bias regulator. Bypass VIN pins to GND pins close to device package with a high quality, low ESR 1- $\mu$ F ceramic capacitor.
GND PAD	9	-	Thermal ground pad and electrical ground for the device.

(1) Input feed forward control with RAMP magnitude  $V_{IN} \times 6\%$ .

## Detailed Pin Description

**PHASE (pin 1):** Output of the internal high and low sides of the internal synchronous FETS. This output drives the external power inductor, or primary side of a coupled inductor for multiple outputs.

**BOOT (pin 2):** Connect a 0.1-μF capacitor between the BOOT pin and the PHASE pin. This provides the necessary level shift voltage to drive the internal upper FET gate.

**UV/OV (pin 3):** Input to the internal window comparator with a 1-V and 5-V reference. The input to the UV/OV pin determines the state of the open drain output of VIN\_G. This does not determine the operating range of the UCC25230. A bypass cap at least 1000 pF is recommended for noise immunity.

**VIN\_G (pin 4):** Open drain output of The UCC25230's internal comparator. The output state is determined by the voltage on the UV/OV pin. The UCC25230 will continue to function regardless of the state of this pin. Used for controlling external circuitry. Maximum voltage to this pin is 5.5 V.

**FB (pin 5):** FB is the inverting input of the UCC25230's internal error amplifier. Connect the output voltage sensing divider to this pin. Internal reference is 2.5 V on the non inverting input.

$$R2 = \left( \left( \frac{V_{OUT}}{2.5} \right) - 1 \right) \times R1 \quad (1)$$

**COMP (pin 6):** The COMP pin is the internal error amplifier's output. The voltage range of COMP is 0 V to 8.3 V. At steady state, a higher COMP pin voltage results in a larger duty cycle. Add compensation components between this pin and FB. The device has input feed forward control which makes PWM RAMP magnitude  $V_{IN} \times 6\%$ .

**VDD (pin 7):** This is the 9-V output of the UCC25230's internal voltage regulator. This output may be used for powering additional circuitry, up to a current of 2 mA, depending on the voltage on the VIN pin. Care must be taken not to exceed the devices total power dissipation.

**VIN (pin 8):** This is the voltage input pin for the UCC25230. It supplies the internal voltage regulator and output switches. Bypass this pin with at least 1-μF low ESR capacitor.

**GND PAD (pin 9):** GND PAD is the ground reference for the whole device. Tie all signal returns to this point.

Functional Block Diagram

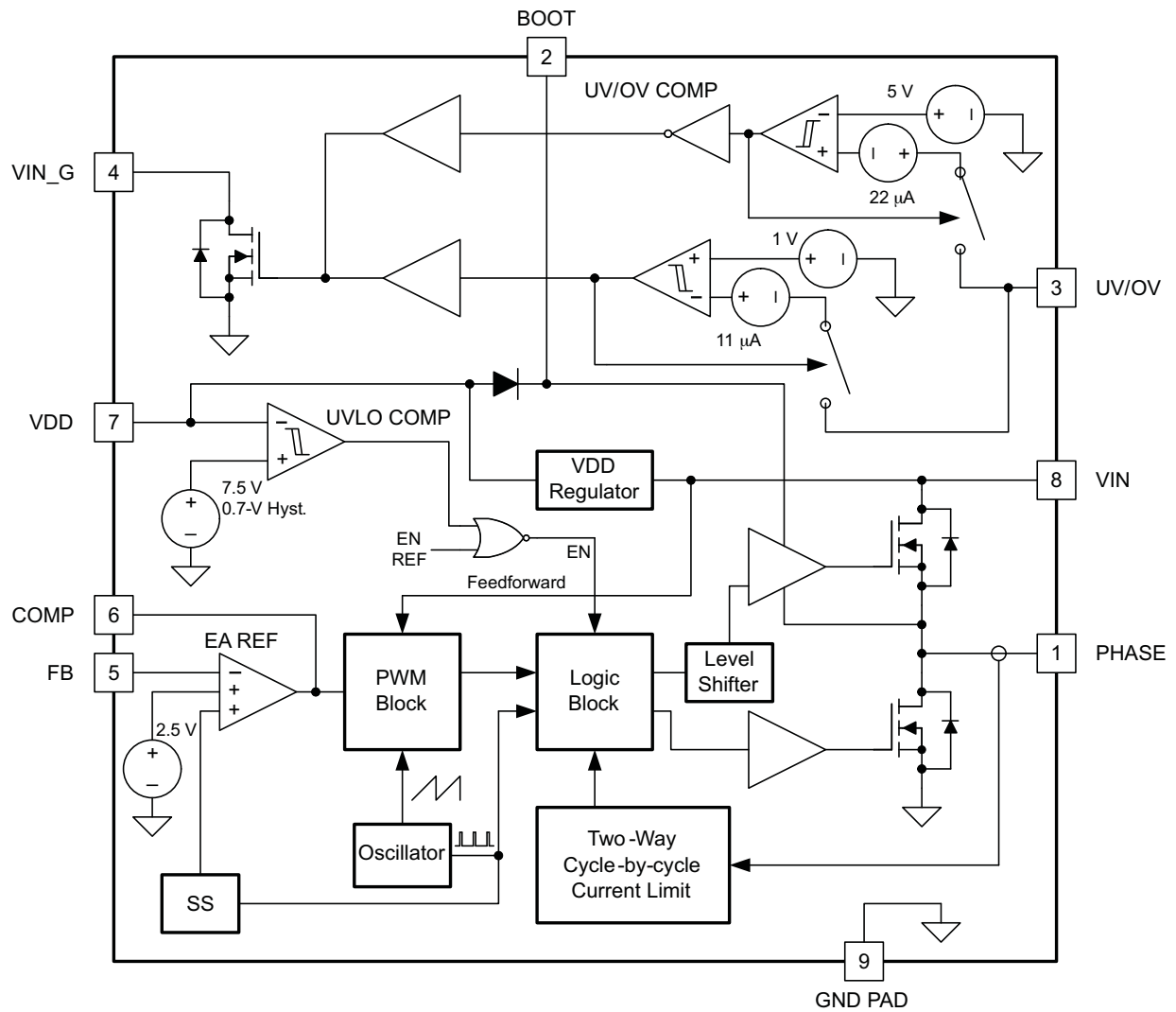

TYPICAL CHARACTERISTICS

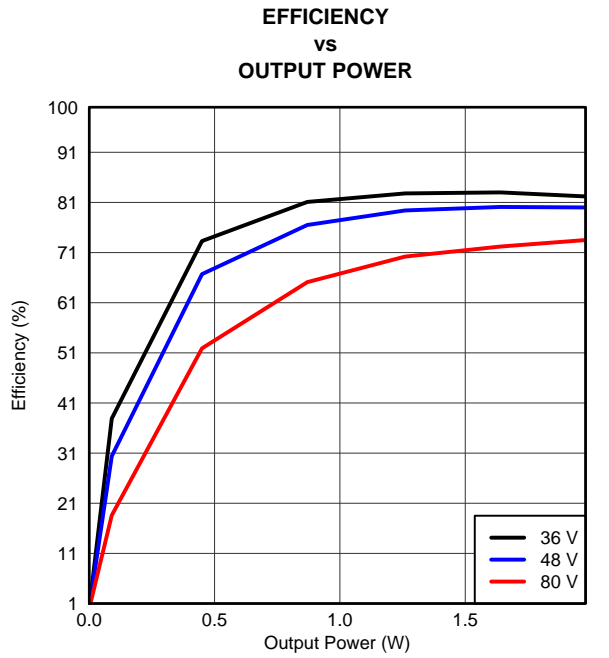

Figure 2.

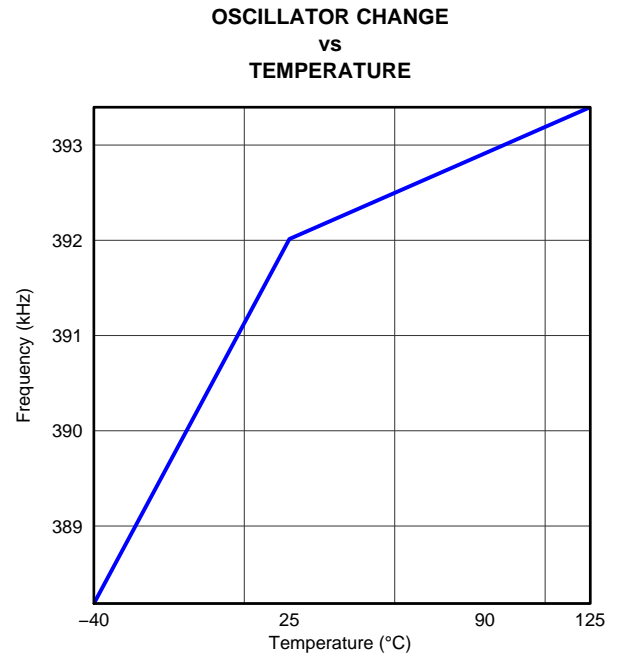

Figure 3.

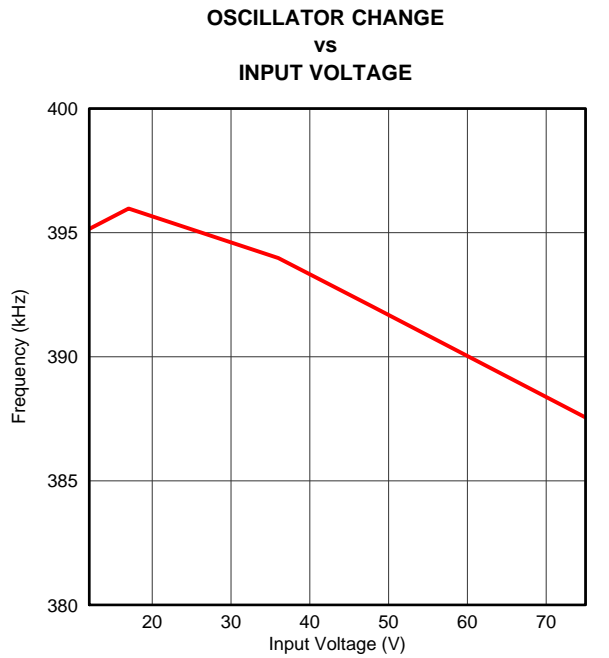

Figure 4.

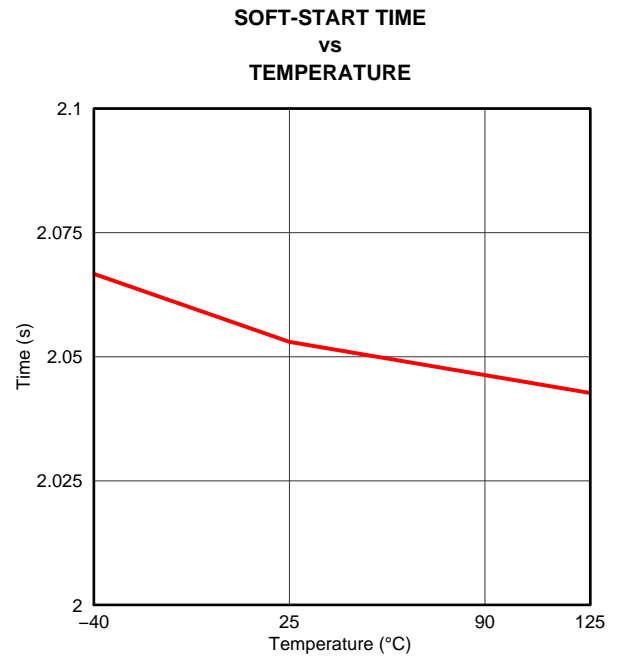

Figure 5.

**TYPICAL CHARACTERISTICS (continued)**  
**VDD CHANGE**  
**vs**  
**TEMPERATURE**

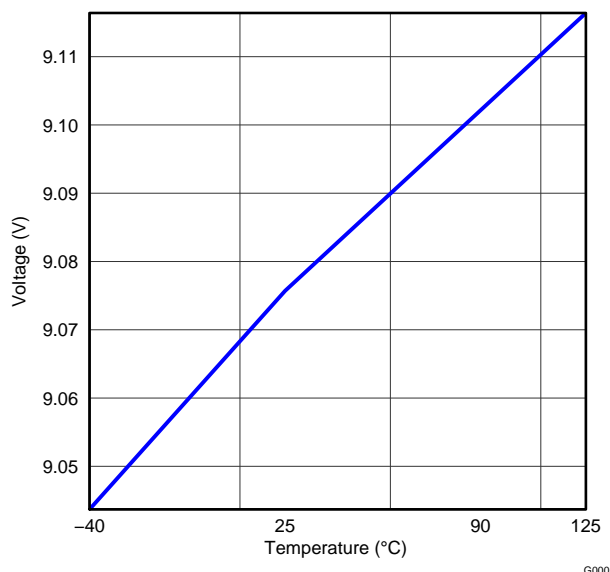

Figure 6.

G000

## APPLICATION INFORMATION

### Detailed Description

The UCC25230 PWM converter integrates all necessary functions to operate as an isolated auxiliary bias supply. It is capable of operating from an input voltage range of 12 V to 100 V (up to 105-V surge), making it ideal for usage in 24-V or 48-V input telecom applications. High-side and low-side power switches are integrated and provide up to 200 mA of peak output current. The UCC25230 is an ideal, complementary solution to primary-side or secondary-side PWM control methodologies as it provides bias voltages necessary for PWM controllers and/or external peripheral circuitry. UCC25230 is capable of delivering a primary-side and/or secondary-side bias voltage for power supplies. As such, UCC25230 is optimized for Texas Instruments' family of UCD3k digital and analog PWM controllers as well as the C2000 family of microcontrollers.

UCC25230 operates using Texas Instruments' Flyback™ Topology, which simplifies design versus a traditional flyback topology. Flyback™ Topology allows a synchronous buck-like design methodology. It also enables a significant reduction in external parts count, and also allows usage of a small 2-winding transformer. The Flyback™ Topology does not require a third transformer winding or opto-isolator for regulation. Circuits employing extra transformer windings compromise dynamic response, and add to the transformer's physical size and cost. The Flyback™ is a portmanteau of flyback and buck since the transformer is connected as a flyback converter and the input to output voltage relationship is similar to a buck derived converter.

Typically, an auxiliary bias supply must be designed such that it is the first device in the system to power up, and be the very last device, in the system, to power down. It must be a robust supply, being able to ride through any fault conditions (OV, UV, OTP, etc) and it also must not prematurely shut down the entire power supply. The UCC25230 was designed with these goals in mind:

- A 2-ms soft start ensures a smooth, monotonic startup on both primary and secondary-side voltages.
- Voltage mode with input voltage feedforward allows optimal output filter design.
- Cycle-by-cycle current limit with frequency foldback permits startup under high-capacitive loading.
- Programmable UV/OV detection circuit.
- A VIN\_G fault output provides a fast propagation open drain signal to indicate when an overvoltage or undervoltage condition has been detected. The UCC25230 is specifically designed to remain operational when a fault is detected in order to allow for fast external shutdown.

**Operation of the Flyback™ Converter**

Figure 7 shows a simplified schematic and the two primary operational states of the Flyback converter. The power supply is a variation of a Flyback converter and consists of a half bridge power stage  $S_{HS}$  and  $S_{LS}$ , transformer, primary side capacitor, diode and output capacitor. The output voltage is regulated indirectly by using the primary side capacitor voltage,  $V_{PRI}$ , as feedback. The Flyback is a portmanteau of flyback and buck since the transformer is connected as a flyback converter and the input to output voltage relationship is similar to a buck derived converter, assuming the converter is operating in steady state and the transformer has negligible leakage inductance.

The  $C_{PRI}$  and  $L_{PRI}$  are charged by the input voltage source  $V_{IN}$  during the time the high side switch  $S_{HS}$  is on. During this time, diode  $D1$  is reversed biased and the load current is supplied by output capacitor  $C_O$ .

During the off time of  $S_{HS}$ ,  $S_{LS}$  conducts and the voltage on  $C_{PRI}$  continues to increase during a portion of the  $S_{LS}$  conduction time. The voltage increase is due to the energy transfer from  $L_{PRI}$  to  $C_{PRI}$ . For the remaining portion of the  $S_{LS}$  conduction time, the  $C_{PRI}$  voltage decreases because of current in  $L_{PRI}$  reverses; see the  $i_{L_{PRI}}$  and  $V_{PRI}$  waveforms in Figure 8. By neglecting the diode voltage drop, conduction dead time and leakage inductance, the input to output voltage conversion ratio can be derived as shown in Equation 2 from the flux balance in  $L_{PRI}$ . It can be seen in Equation 2 that the input to output relationship is the same as a buck-derived converter with transformer isolation. The dc voltage  $V_{PRI}$  on the primary side capacitor in Equation 3 has the same linear relationship to the input voltage as a buck converter.

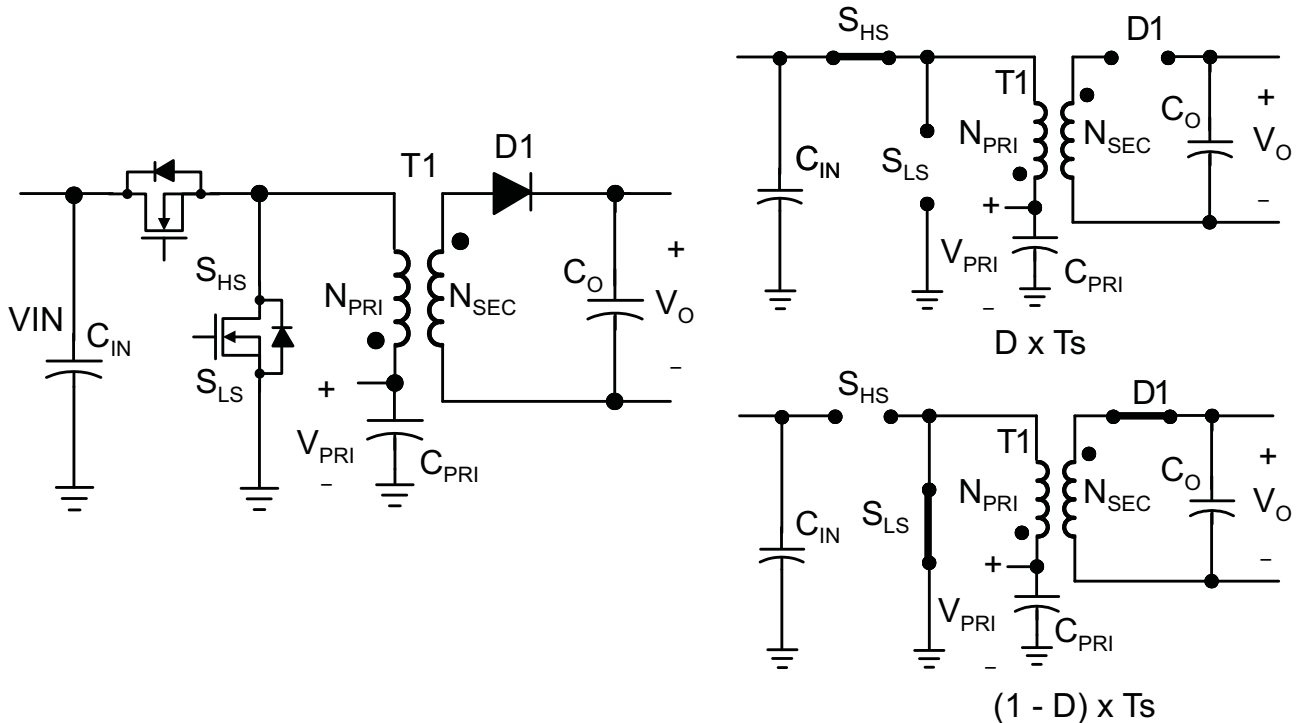

**Figure 7. Simplified Schematic with Two Primary Operational States**

The small signal model for the Flyback is derived by changing the transformer to the inductor equivalent and reflecting the output filter to the primary side for the circuit shown in Figure 7. Assuming negligible leakage inductance and equivalent series resistance for the capacitors, the  $V_{PRI}$  transfer function is similar to the voltage mode control buck power stage transfer function with the exception that the  $C_O$  and load are in parallel with the  $C_{PRI}$  only for the  $1-D$  time. The device has input feed forward control which makes PWM RAMP magnitude  $V_{IN} \times 6\%$ .

$$\frac{V_O}{V_{IN}} = \frac{N_{SEC}}{N_{PRI}} \times D \tag{2}$$

$$\frac{V_{PRI}}{V_{IN}} = D \tag{3}$$

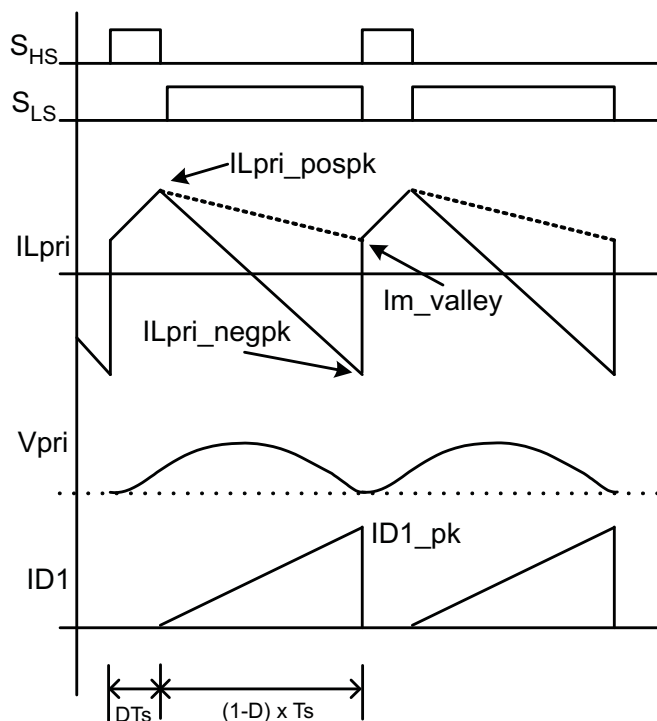

Figure 8. Simplified Voltage and Current Waveforms

Typical Application Diagram

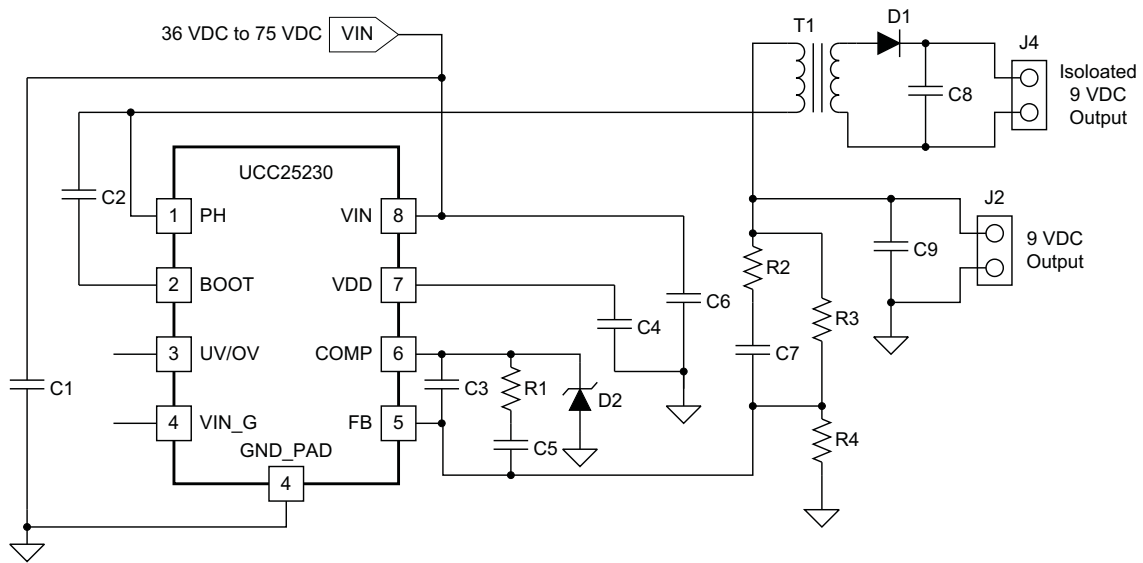

Figure 9. Typical Application Diagram

REVISION HISTORY

Changes from Revision A (November, 2011) to Revision B	Page
• Added Integrated 110-V High and Low-Side Switches feature bullet .....	1
• Added note, Input feed forward control with RAMP magnitude $V_{IN} \times 6\%$ . .....	6
• Added COMP pin description, The device has input feed forward control which makes PWM RAMP magnitude $V_{IN} \times 6\%$ . .....	7
• Deleted Averaging the secondary side components, an approximate transfer function is shown in and pole location in . $R_O$ is the secondary side load resistance and the $R_{LM}$ is the dc resistance of the primary. $R_i$ is the inverse of the Comp to PH gm. ....	13
• Added The device has input feed forward control which makes PWM RAMP magnitude $V_{IN} \times 6\%$ . ....	13

**PACKAGING INFORMATION**

Orderable Device	Status (1)	Package Type	Package Drawing	Pins	Package Qty	Eco Plan (2)	Lead/Ball Finish	MSL Peak Temp (3)	Op Temp (°C)	Top-Side Markings (4)	Samples
UCC25230DRMR	ACTIVE	VSON	DRM	8	3000	Green (RoHS & no Sb/Br)	CU NIPDAU	Level-1-260C-UNLIM	-40 to 125	25230	<a href="#">Samples</a>
UCC25230DRMT	ACTIVE	VSON	DRM	8	250	Green (RoHS & no Sb/Br)	CU NIPDAU	Level-1-260C-UNLIM	-40 to 125	25230	<a href="#">Samples</a>

(1) The marketing status values are defined as follows:

**ACTIVE:** Product device recommended for new designs.

**LIFEBUY:** TI has announced that the device will be discontinued, and a lifetime-buy period is in effect.

**NRND:** Not recommended for new designs. Device is in production to support existing customers, but TI does not recommend using this part in a new design.

**PREVIEW:** Device has been announced but is not in production. Samples may or may not be available.

**OBSELETE:** TI has discontinued the production of the device.

(2) Eco Plan - The planned eco-friendly classification: Pb-Free (RoHS), Pb-Free (RoHS Exempt), or Green (RoHS & no Sb/Br) - please check <http://www.ti.com/productcontent> for the latest availability information and additional product content details.

**TBD:** The Pb-Free/Green conversion plan has not been defined.

**Pb-Free (RoHS):** TI's terms "Lead-Free" or "Pb-Free" mean semiconductor products that are compatible with the current RoHS requirements for all 6 substances, including the requirement that lead not exceed 0.1% by weight in homogeneous materials. Where designed to be soldered at high temperatures, TI Pb-Free products are suitable for use in specified lead-free processes.

**Pb-Free (RoHS Exempt):** This component has a RoHS exemption for either 1) lead-based flip-chip solder bumps used between the die and package, or 2) lead-based die adhesive used between the die and leadframe. The component is otherwise considered Pb-Free (RoHS compatible) as defined above.

**Green (RoHS & no Sb/Br):** TI defines "Green" to mean Pb-Free (RoHS compatible), and free of Bromine (Br) and Antimony (Sb) based flame retardants (Br or Sb do not exceed 0.1% by weight in homogeneous material)

(3) MSL, Peak Temp. -- The Moisture Sensitivity Level rating according to the JEDEC industry standard classifications, and peak solder temperature.

(4) Multiple Top-Side Markings will be inside parentheses. Only one Top-Side Marking contained in parentheses and separated by a "~" will appear on a device. If a line is indented then it is a continuation of the previous line and the two combined represent the entire Top-Side Marking for that device.

**Important Information and Disclaimer:**The information provided on this page represents TI's knowledge and belief as of the date that it is provided. TI bases its knowledge and belief on information provided by third parties, and makes no representation or warranty as to the accuracy of such information. Efforts are underway to better integrate information from third parties. TI has taken and continues to take reasonable steps to provide representative and accurate information but may not have conducted destructive testing or chemical analysis on incoming materials and chemicals. TI and TI suppliers consider certain information to be proprietary, and thus CAS numbers and other limited information may not be available for release.

In no event shall TI's liability arising out of such information exceed the total purchase price of the TI part(s) at issue in this document sold by TI to Customer on an annual basis.

**TAPE AND REEL INFORMATION**

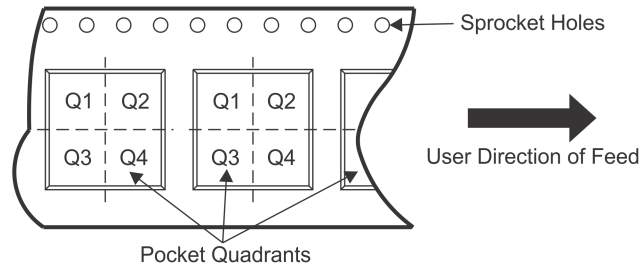
**QUADRANT ASSIGNMENTS FOR PIN 1 ORIENTATION IN TAPE**

\*All dimensions are nominal

Device	Package Type	Package Drawing	Pins	SPQ	Reel Diameter (mm)	Reel Width W1 (mm)	A0 (mm)	B0 (mm)	K0 (mm)	P1 (mm)	W (mm)	Pin1 Quadrant
UCC25230DRMR	VSON	DRM	8	3000	330.0	12.4	4.25	4.25	1.15	8.0	12.0	Q2
UCC25230DRMT	VSON	DRM	8	250	180.0	12.4	4.25	4.25	1.15	8.0	12.0	Q2

**TAPE AND REEL BOX DIMENSIONS**

\*All dimensions are nominal

Device	Package Type	Package Drawing	Pins	SPQ	Length (mm)	Width (mm)	Height (mm)
UCC25230DRMR	VSON	DRM	8	3000	367.0	367.0	35.0
UCC25230DRMT	VSON	DRM	8	250	210.0	185.0	35.0

DRM (S-PVSON-N8)

PLASTIC SMALL OUTLINE NO-LEAD

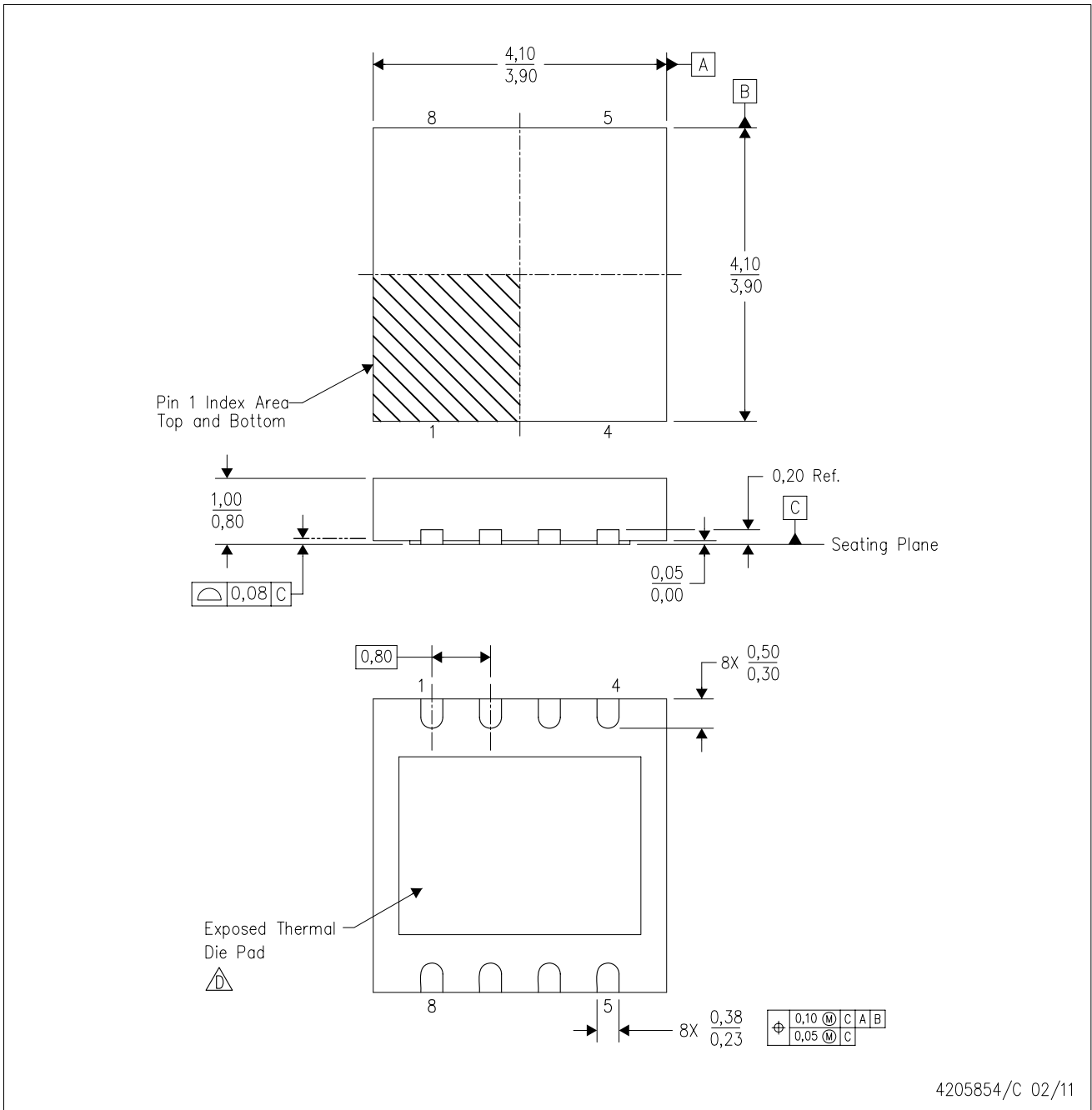

- NOTES:
- A. All linear dimensions are in millimeters. Dimensioning and tolerancing per ASME Y14.5M-1994.
  - B. This drawing is subject to change without notice.
  - C. SON (Small Outline No-Lead) package configuration.
  - D. The package thermal pad must be soldered to the board for thermal and mechanical performance. See the Product Data Sheet for details regarding the exposed thermal pad dimensions.

### THERMAL INFORMATION

This package incorporates an exposed thermal pad that is designed to be attached directly to an external heatsink. The thermal pad must be soldered directly to the printed circuit board (PCB). After soldering, the PCB can be used as a heatsink. In addition, through the use of thermal vias, the thermal pad can be attached directly to the appropriate copper plane shown in the electrical schematic for the device, or alternatively, can be attached to a special heatsink structure designed into the PCB. This design optimizes the heat transfer from the integrated circuit (IC).

For information on the Quad Flatpack No-Lead (QFN) package and its advantages, refer to Application Report, Quad Flatpack No-Lead Logic Packages, Texas Instruments Literature No. SCBA017. This document is available at [www.ti.com](http://www.ti.com).

The exposed thermal pad dimensions for this package are shown in the following illustration.

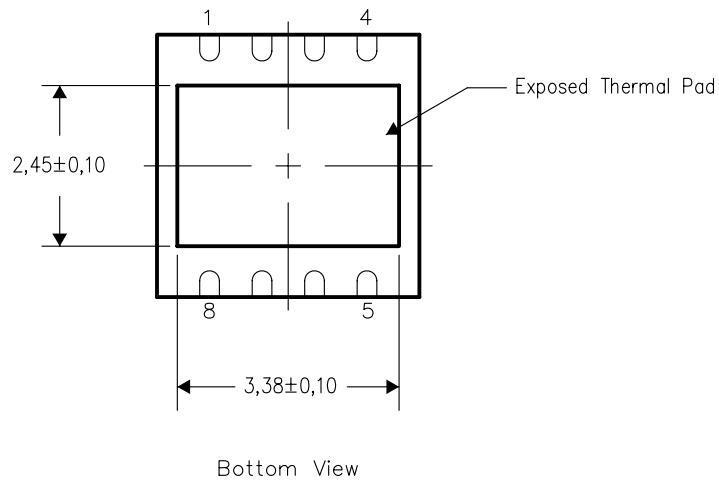

NOTE: All linear dimensions are in millimeters

Exposed Thermal Pad Dimensions



## IMPORTANT NOTICE

Texas Instruments Incorporated and its subsidiaries (TI) reserve the right to make corrections, enhancements, improvements and other changes to its semiconductor products and services per JESD46, latest issue, and to discontinue any product or service per JESD48, latest issue. Buyers should obtain the latest relevant information before placing orders and should verify that such information is current and complete. All semiconductor products (also referred to herein as "components") are sold subject to TI's terms and conditions of sale supplied at the time of order acknowledgment.

TI warrants performance of its components to the specifications applicable at the time of sale, in accordance with the warranty in TI's terms and conditions of sale of semiconductor products. Testing and other quality control techniques are used to the extent TI deems necessary to support this warranty. Except where mandated by applicable law, testing of all parameters of each component is not necessarily performed.

TI assumes no liability for applications assistance or the design of Buyers' products. Buyers are responsible for their products and applications using TI components. To minimize the risks associated with Buyers' products and applications, Buyers should provide adequate design and operating safeguards.

TI does not warrant or represent that any license, either express or implied, is granted under any patent right, copyright, mask work right, or other intellectual property right relating to any combination, machine, or process in which TI components or services are used. Information published by TI regarding third-party products or services does not constitute a license to use such products or services or a warranty or endorsement thereof. Use of such information may require a license from a third party under the patents or other intellectual property of the third party, or a license from TI under the patents or other intellectual property of TI.

Reproduction of significant portions of TI information in TI data books or data sheets is permissible only if reproduction is without alteration and is accompanied by all associated warranties, conditions, limitations, and notices. TI is not responsible or liable for such altered documentation. Information of third parties may be subject to additional restrictions.

Resale of TI components or services with statements different from or beyond the parameters stated by TI for that component or service voids all express and any implied warranties for the associated TI component or service and is an unfair and deceptive business practice. TI is not responsible or liable for any such statements.

Buyer acknowledges and agrees that it is solely responsible for compliance with all legal, regulatory and safety-related requirements concerning its products, and any use of TI components in its applications, notwithstanding any applications-related information or support that may be provided by TI. Buyer represents and agrees that it has all the necessary expertise to create and implement safeguards which anticipate dangerous consequences of failures, monitor failures and their consequences, lessen the likelihood of failures that might cause harm and take appropriate remedial actions. Buyer will fully indemnify TI and its representatives against any damages arising out of the use of any TI components in safety-critical applications.

In some cases, TI components may be promoted specifically to facilitate safety-related applications. With such components, TI's goal is to help enable customers to design and create their own end-product solutions that meet applicable functional safety standards and requirements. Nonetheless, such components are subject to these terms.

No TI components are authorized for use in FDA Class III (or similar life-critical medical equipment) unless authorized officers of the parties have executed a special agreement specifically governing such use.

Only those TI components which TI has specifically designated as military grade or "enhanced plastic" are designed and intended for use in military/aerospace applications or environments. Buyer acknowledges and agrees that any military or aerospace use of TI components which have **not** been so designated is solely at the Buyer's risk, and that Buyer is solely responsible for compliance with all legal and regulatory requirements in connection with such use.

TI has specifically designated certain components as meeting ISO/TS16949 requirements, mainly for automotive use. In any case of use of non-designated products, TI will not be responsible for any failure to meet ISO/TS16949.

### Products

Audio	<a href="http://www.ti.com/audio">www.ti.com/audio</a>
Amplifiers	<a href="http://amplifier.ti.com">amplifier.ti.com</a>
Data Converters	<a href="http://dataconverter.ti.com">dataconverter.ti.com</a>
DLP® Products	<a href="http://www.dlp.com">www.dlp.com</a>
DSP	<a href="http://dsp.ti.com">dsp.ti.com</a>
Clocks and Timers	<a href="http://www.ti.com/clocks">www.ti.com/clocks</a>
Interface	<a href="http://interface.ti.com">interface.ti.com</a>
Logic	<a href="http://logic.ti.com">logic.ti.com</a>
Power Mgmt	<a href="http://power.ti.com">power.ti.com</a>
Microcontrollers	<a href="http://microcontroller.ti.com">microcontroller.ti.com</a>
RFID	<a href="http://www.ti-rfid.com">www.ti-rfid.com</a>
OMAP Applications Processors	<a href="http://www.ti.com/omap">www.ti.com/omap</a>
Wireless Connectivity	<a href="http://www.ti.com/wirelessconnectivity">www.ti.com/wirelessconnectivity</a>

### Applications

Automotive and Transportation	<a href="http://www.ti.com/automotive">www.ti.com/automotive</a>
Communications and Telecom	<a href="http://www.ti.com/communications">www.ti.com/communications</a>
Computers and Peripherals	<a href="http://www.ti.com/computers">www.ti.com/computers</a>
Consumer Electronics	<a href="http://www.ti.com/consumer-apps">www.ti.com/consumer-apps</a>
Energy and Lighting	<a href="http://www.ti.com/energy">www.ti.com/energy</a>
Industrial	<a href="http://www.ti.com/industrial">www.ti.com/industrial</a>
Medical	<a href="http://www.ti.com/medical">www.ti.com/medical</a>
Security	<a href="http://www.ti.com/security">www.ti.com/security</a>
Space, Avionics and Defense	<a href="http://www.ti.com/space-avionics-defense">www.ti.com/space-avionics-defense</a>
Video and Imaging	<a href="http://www.ti.com/video">www.ti.com/video</a>

### TI E2E Community

[e2e.ti.com](http://e2e.ti.com)