

DOS-1204-GE

SICK
Sensor Intelligence.



Ordering information

Type	Part no.
DOS-1204-GE	6048153

Other models and accessories → www.sick.com/

Detailed technical data

Technical specifications

Accessory group	Plug connectors and cables
Accessory family	Field-attachable connectors
Connection type head A	Female connector, M12, 4-pin, straight, D-coded
Connection type head B	-
Connection type	IDC quick connection
Locking plug connector	Quick screw connection
Locking nut material	Zinc die-cast, nickel-plated
Cable	CAT5, CAT5e
Shielding	Shielded
Permitted cable diameter	4 mm ... 8 mm
Permitted cross-section	0.14 mm ² ... 0.34 mm ²
Reference voltage	≤ 60 V
Current loading	1.75 A
Signal type	Ethernet
Enclosure rating	IP67
Description	Head A: female connector, M12, 4-pin, straight, D-coded, shielded, for cable diameter 4 mm ... 8 mm Head B: -
Ambient operating temperature	Head -40 °C ... +85 °C

Classifications

ECl@ss 5.0	27279290
ECl@ss 5.1.4	27279290
ECl@ss 6.0	27279221
ECl@ss 6.2	27279221
ECl@ss 7.0	27440104
ECl@ss 8.0	27440104
ECl@ss 8.1	27440104
ECl@ss 9.0	27440102
ETIM 5.0	EC002635
ETIM 6.0	EC002635
UNSPSC 16.0901	39121421

Dimensional drawing (Dimensions in mm (inch))

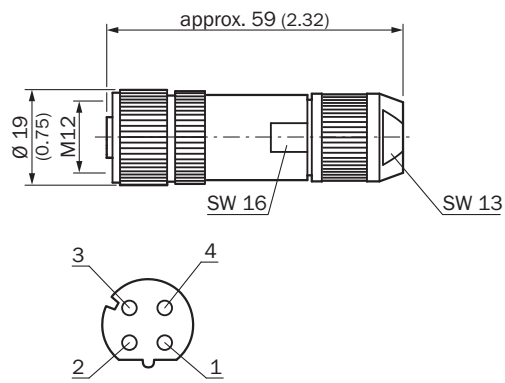

SICK AT A GLANCE

SICK is one of the leading manufacturers of intelligent sensors and sensor solutions for industrial applications. A unique range of products and services creates the perfect basis for controlling processes securely and efficiently, protecting individuals from accidents and preventing damage to the environment.

We have extensive experience in a wide range of industries and understand their processes and requirements. With intelligent sensors, we can deliver exactly what our customers need. In application centers in Europe, Asia and North America, system solutions are tested and optimized in accordance with customer specifications. All this makes us a reliable supplier and development partner.

Comprehensive services complete our offering: SICK LifeTime Services provide support throughout the machine life cycle and ensure safety and productivity.

For us, that is “Sensor Intelligence.”

WORLDWIDE PRESENCE:

Contacts and other locations –www.sick.com