

1A, Ultra-Low Dropout, Ultra-Fast CMOS LDO Regulator

General Description

The RT9187 is a high-performance, 1A LDO regulator, offering extremely high PSRR and ultra-low dropout. Ideal for portable RF and wireless applications with demanding performance and space requirements.

A noise reduction pin is also available for further reduction of output noise. Regulator ground current increases only slightly in dropout, further prolonging the battery life. The RT9187 also works with low-ESR ceramic capacitors, reducing the amount of board space necessary for power applications, critical in hand-held wireless devices.

The RT9187 consumes less than 0.1uA in shutdown mode and has fast turn-on time less than 40µs. The other features include ultra-low dropout voltage, high output accuracy, current limiting protection, and high ripple rejection ratio. Available in the VDFN-8L 3x3 and SOP-8 (Exposed Pad) package.

Ordering Information

RT9187(-□□)□□	
	Package Type
	QV : VDFN-8L 3x3 (V-Type)
	SP : SOP-8 (Exposed Pad-Option 1)
	Operating Temperature Range
	P : Pb Free with Commercial Standard
	G : Green (Halogen Free with Commercial Standard)
	None : Adjustable Output
	Fixed Output Voltage Code
	10 : 1.0V
	11 : 1.1V
	:
	32 : 3.2V
	33 : 3.3V
	1L : 1.34V

Note :

Richtek Pb-free and Green products are :

- ▶RoHS compliant and compatible with the current requirements of IPC/JEDEC J-STD-020.
- ▶Suitable for use in SnPb or Pb-free soldering processes.
- ▶100% matte tin (Sn) plating.

Features

- Ultra-Low-Noise for RF Application
- Ultra-Fast Response in Line/Load Transient
- Quick Start-Up (Typically 40µs)
- < 0.1uA Standby Current When Shutdown
- Low Dropout : 240mV at 1A
- Wide Operating Voltage Ranges : 2.5V to 5.5V
- TTL-Logic-Controlled Shutdown Input
- Current Limiting Protection
- Thermal Shutdown Protection
- Only 2.2uF Output Capacitor Required for Stability
- High Power Supply Rejection Ratio
- RoHS Compliant and 100% Lead (Pb)-Free

Applications

- CDMA/GSM Cellular Handsets
- Battery-Powered Equipment
- Laptop, Palmtops, Notebook Computers
- Hand-Held Instruments
- Mini PCI & PCI-Express Cards
- PCMCIA & New Cards
- Portable Information Appliances

Marking Information

For marking information, contact our sales representative directly or through a RichTek distributor located in your area, otherwise visit our website for detail.

Pin Configurations

(TOP VIEW)

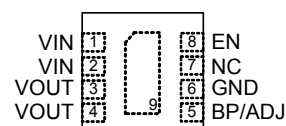

VDFN-8L 3x3

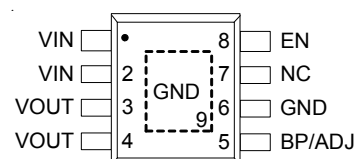

SOP-8 (Exposed Pad)

Typical Application Circuit

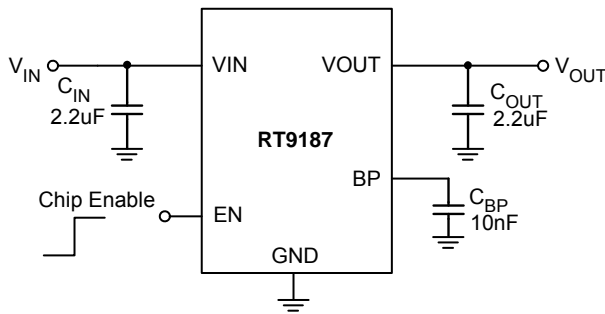

Figure 1. Fixed Operation

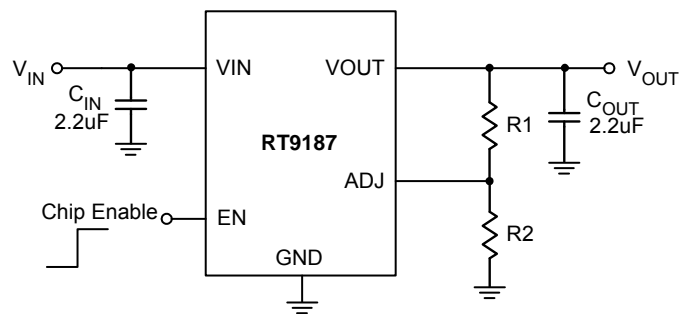

Figure 2. Adjustable Operation

$$V_{OUT} = 0.8 \times \left(1 + \frac{R_1}{R_2}\right) \text{ Volts}$$

Note: The value of R2 should be less than 80k to maintain regulation.

Function Pin Description

Pin No.		Pin Name	Pin Function
Fixed Output Voltage	Adjustable Output Voltage		
1	1	VIN	Supply Input.
2	2	VIN	Supply Input.
3	3	VOUT	Regulator Output.
4	4	VOUT	Regulator Output.
5	--	BP	Noise Reduction. Connecting a 10nF capacitor to GND to reduce output noise.
--	5	ADJ	If external feedback resistors are applied, the output voltage will be: $V_{OUT} = 0.8 \times \left(1 + \frac{R_1}{R_2}\right) \text{ Volts}$
6	6	GND	Ground
7	7	NC	No Internal Connection.
8	8	EN	Enable Input Logic, Active High. When the EN goes to a logic low, the device is in shutdown mode.
Exposed Pad (9)		NC	No Internal Connection. The exposed pad must be soldered to a large PCB and connected to GND for maximum power dissipation.

Function Block Diagram

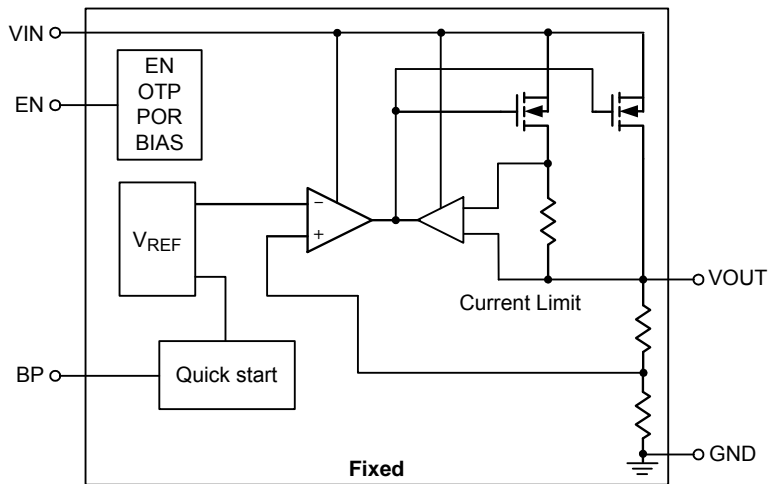
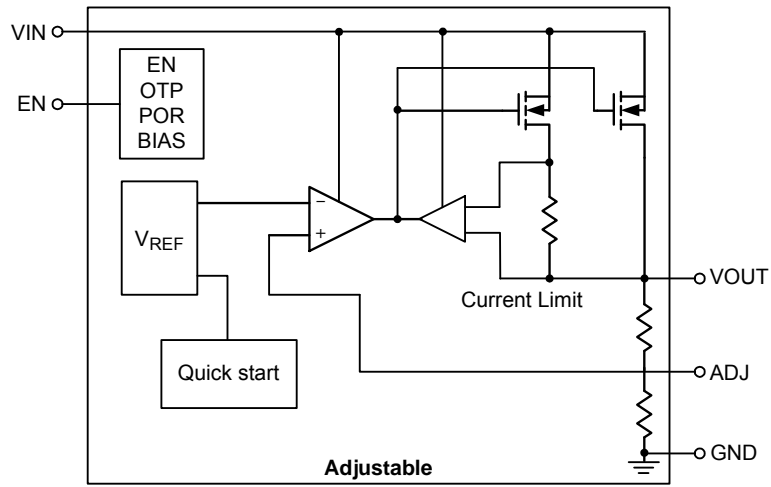

Absolute Maximum Ratings (Note 1)

- Supply Input Voltage ----- 6V
- EN Input Voltage ----- 6V
- Power Dissipation, P_D @ $T_A = 25^\circ\text{C}$
 - VDFN-8L 3x3 ----- 0.923W
 - SOP-8 (Exposed Pad) ----- 1.33W
- Package Thermal Resistance (Note 9)
 - VDFN-8L 3x3, θ_{JC} ----- 8.2°C/W
 - VDFN-8L 3x3, θ_{JA} ----- 108°C/W
 - SOP-8 (Exposed Pad), θ_{JC} ----- 15°C/W
 - SOP-8 (Exposed Pad)-8, θ_{JA} ----- 75°C/W
- Lead Temperature (Soldering, 10 sec.) ----- 260°C
- Junction Temperature ----- 150°C
- Storage Temperature Range ----- -65°C to 150°C
- ESD Susceptibility (Note 2)
 - HBM ----- 2kV
 - MM ----- 200V

Recommended Operating Conditions (Note 3)

- Supply Input Voltage ----- 2.5V to 5.5V
- EN Input Voltage ----- 0V to 5.5V
- Junction Temperature Range ----- -40°C to 125°C
- Ambient Temperature Range ----- -40°C to 85°C

Electrical Characteristics

($V_{IN} = V_{OUT} + 1V$, $V_{EN} = V_{IN}$, $C_{IN} = C_{OUT} = 2.2\mu\text{F}$ (Ceramic) & $C_{BP} = 10\text{nF}$, $T_A = 25^\circ\text{C}$ unless otherwise specified)

Parameter	Symbol	Test Conditions	Min	Typ	Max	Units	
Output Voltage Accuracy (Fixed Output Voltage)	ΔV_{OUT}	$I_{OUT} = 10\text{mA}$	-2	0	+2	%	
Output Voltage Range (Adjustable)	V_{OUT_Adj}		0.8	-	4.5	V	
Quiescent Current (Note 6)	I_Q	$V_{EN} \geq V_{IH}$, $I_{OUT} = 0\text{mA}$	--	380	500	μA	
Standby Current (Note 7)	I_{STBY}	$V_{EN} \leq V_{IL}$, $V_{IN} = 3.3\text{V}$	--	0.1	1	μA	
Current Limit	I_{LIM}	$R_{LOAD} = 0.5\Omega$, $V_{IN} = 3.3\text{V}$	2	2.8	3	A	
Dropout Voltage (Note 4)	V_{DROP}	$I_{OUT} = 0.25\text{A}$ (Note 8)	--	60	100	mV	
		$I_{OUT} = 0.5\text{A}$	--	120	180		
		$I_{OUT} = 1.0\text{A}$	--	240	360		
Load Regulation (Note 5) (Fixed Output Voltage)	ΔV_{LOAD}	$V_{IN} = (V_{OUT} + 0.5\text{V})$ $10\text{mA} < I_{OUT} < 1.0\text{A}$	--	0.4	--	%/A	
EN Threshold	Logic-Low Voltage	V_{IL}	$V_{IN} = 3.3\text{V}$	--	-	0.6	V
	Logic-High Voltage	V_{IH}	$V_{IN} = 3.3\text{V}$	1.8	-	--	
Enable Pin Current	I_{EN}	$V_{IN} = 3.3\text{V}$, Enable	--	0.1	1	μA	

To be continued

Parameter		Symbol	Test Conditions	Min	Typ	Max	Units
Power Supply Rejection Rate	f = 100Hz	PSRR	I _{OUT} = 300mA	--	-60	-	dB
	f = 10kHz			--	-50	-	
Line Regulation		ΔV _{LINE}	V _{IN} = (V _{OUT} +0.5) to 5.5V, I _{OUT} = 1mA	--	--	0.3	%
Start-Up Time		T _{Start_Up}	R _{LOAD} = 3Ω, 1nF ≤ C _{BP} ≤ 0.1μF	--	40	--	μs
Thermal Shutdown Temperature		T _{SD}		--	170	--	°C
Thermal Shutdown Hysteresis		ΔT _{SD}		--	30	--	
ADJ							
Reference Voltage Tolerance		V _{REF}		0.784	0.8	0.816	V
ADJ Pin Current		I _{ADJ}	V _{ADJ} = V _{REF}	--	10	100	nA

Note 1. Stresses listed as the above “Absolute Maximum Ratings” may cause permanent damage to the device. These are for stress ratings. Functional operation of the device at these or any other conditions beyond those indicated in the operational sections of the specifications is not implied. Exposure to absolute maximum rating conditions for extended periods may remain possibility to affect device reliability.

Note 2. Devices are ESD sensitive. Handling precaution is recommended.

Note 3. The device is not guaranteed to function outside its operating conditions.

Note 4. The dropout voltage is defined as V_{IN} - V_{OUT}, which is measured when V_{OUT} is V_{OUT(NORMAL)} - 100mV.

Note 5. Regulation is measured at constant junction temperature by using a 2ms current pulse. Devices are tested for load regulation in the load range from 10mA to 1.0A.

Note 6. Quiescent, or ground current, is the difference between input and output currents. It is defined by I_Q = I_{IN} - I_{OUT} under no load condition (I_{OUT} = 0mA). The total current drawn from the supply is the sum of the load current plus the ground pin current.

Note 7. Standby current is the input current drawn by a regulator when the output voltage is disabled by a shutdown signal (V_{EN} >1.8V).

Note 8. Performance at -5°C ≤ T_A ≤ 85°C is assured by design.

Note 9. θ_{JA} is measured in the natural convection at T_A = 25°C on a low effective thermal conductivity test board of JEDEC 51-3 thermal measurement standard.

Typical Operating Characteristics

($C_{OUT} = 2.2\mu F/x5R$, $C_{BP} = 10nF$, unless otherwise specified)

Quiescent Current vs. Temperature

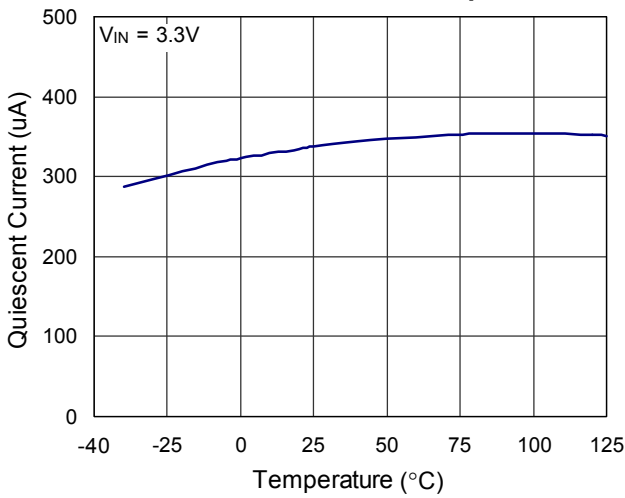

Quiescent Current vs. Input Voltage

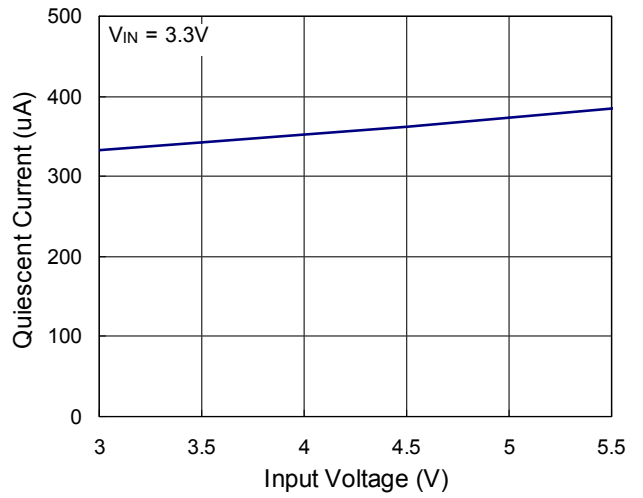

Dropout Voltage vs. Load Current

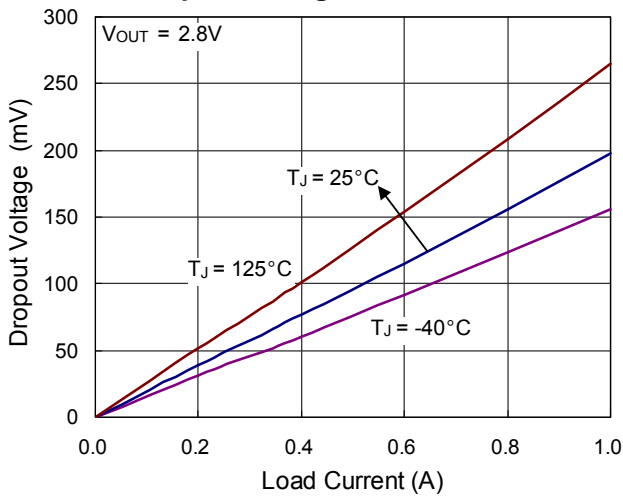

Current Limit

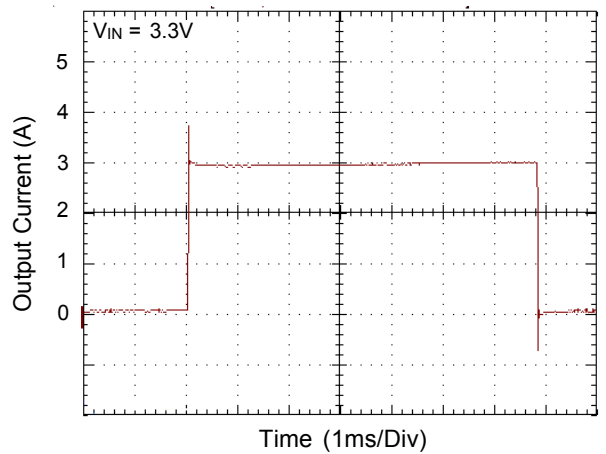

EN Pin Shutdown Response

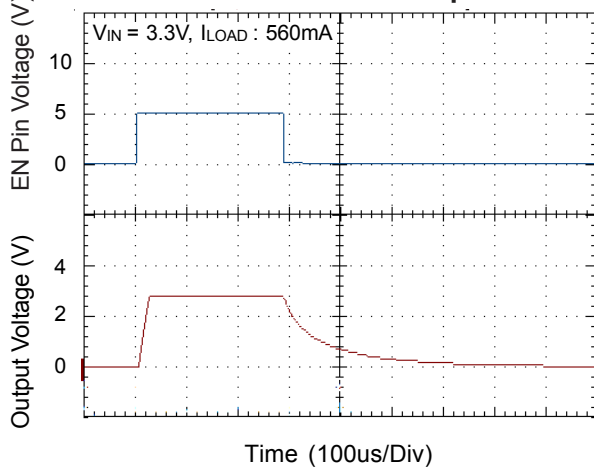

Start Up

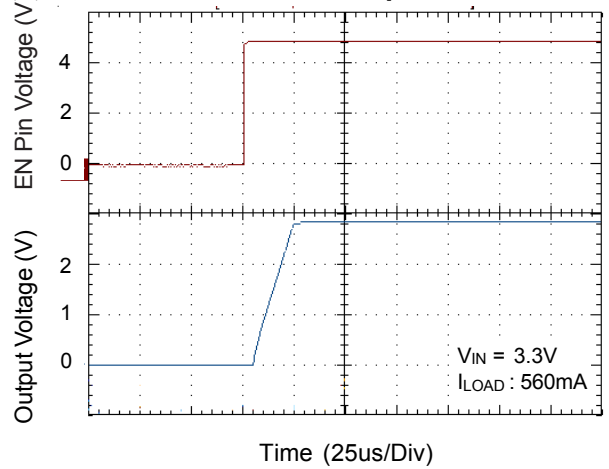

Line Transient Response

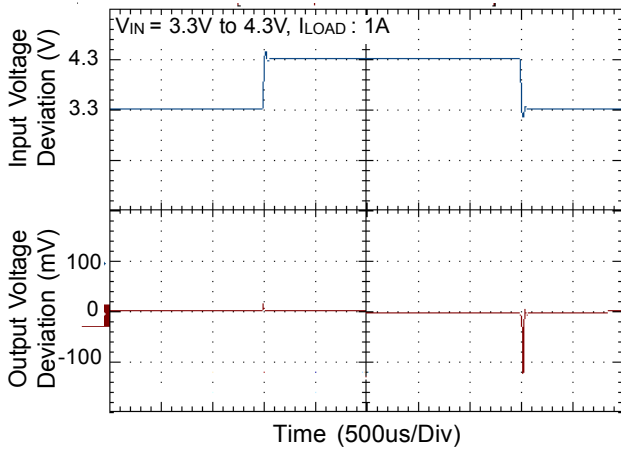

Line Transient Response

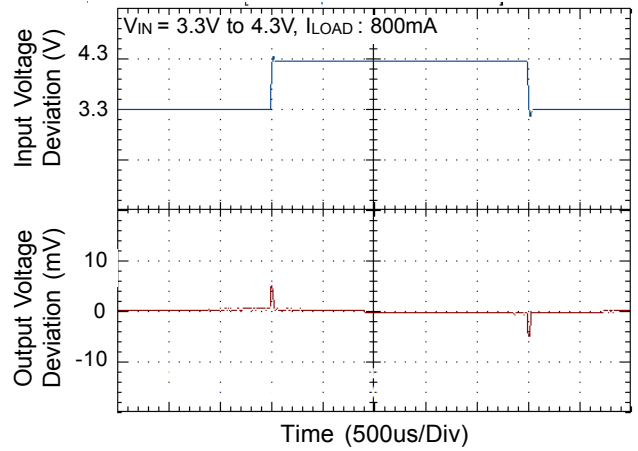

Load Transient Response

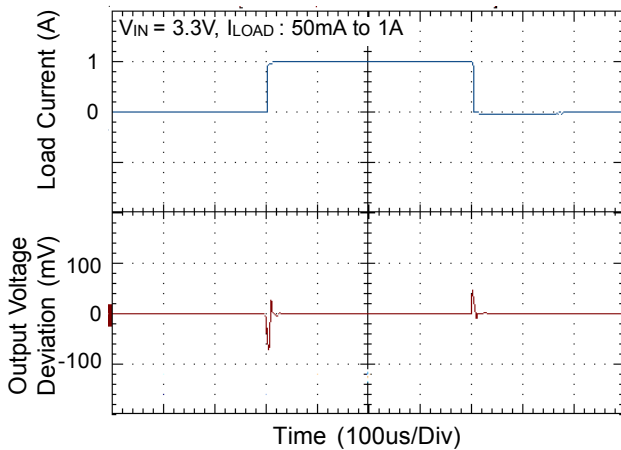

Load Transient Response

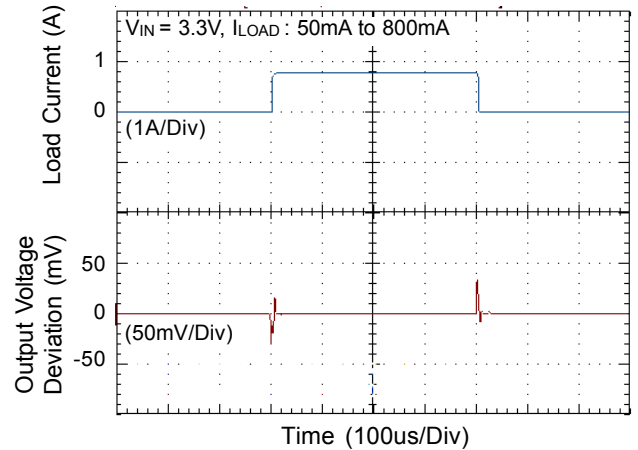

PSRR

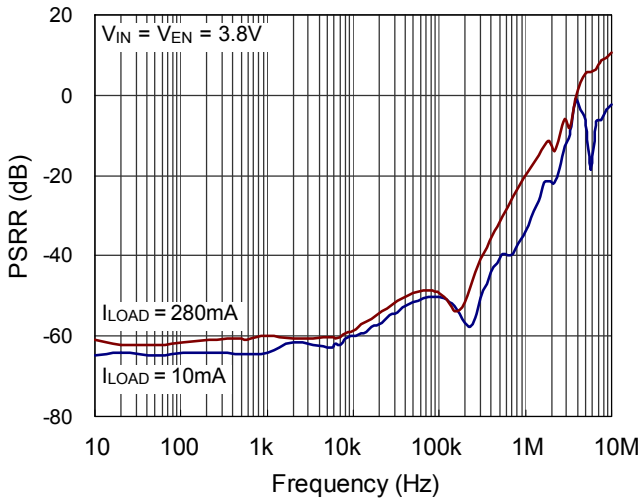

Region of Stable C_{OUT} ESR vs. Load Current

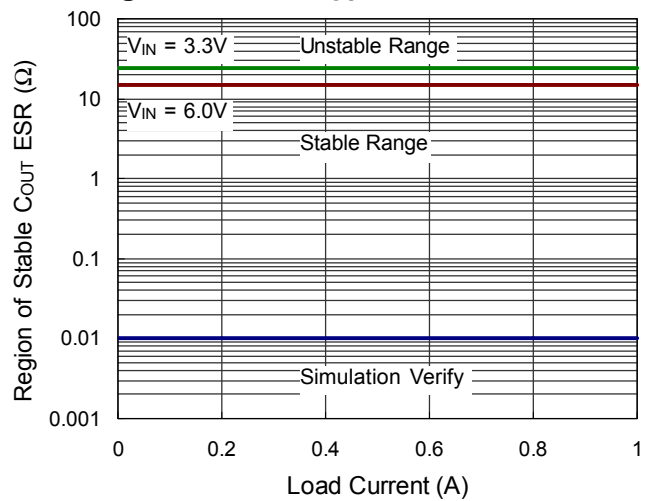

Outline Dimension

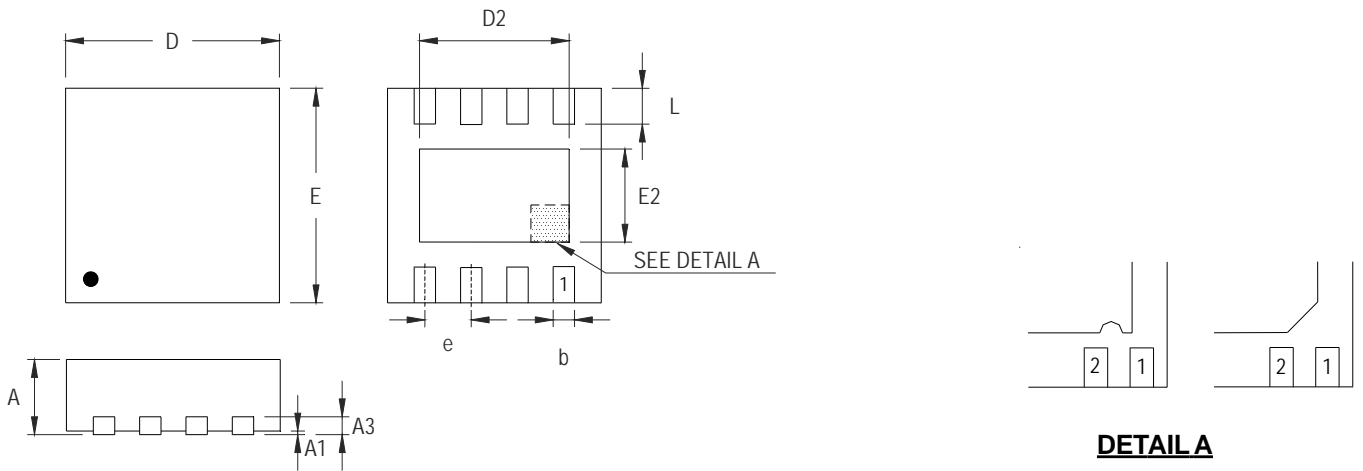

DETAIL A

Pin #1 ID and Tie Bar Mark Options

Note : The configuration of the Pin #1 identifier is optional, but must be located within the zone indicated.

Symbol	Dimensions In Millimeters		Dimensions In Inches	
	Min	Max	Min	Max
A	0.800	1.000	0.031	0.039
A1	0.000	0.050	0.000	0.002
A3	0.175	0.250	0.007	0.010
b	0.200	0.300	0.008	0.012
D	2.950	3.050	0.116	0.120
D2	2.100	2.350	0.083	0.093
E	2.950	3.050	0.116	0.120
E2	1.350	1.600	0.053	0.063
e	0.650		0.026	
L	0.425	0.525	0.017	0.021

V-Type 8L DFN 3x3 Package

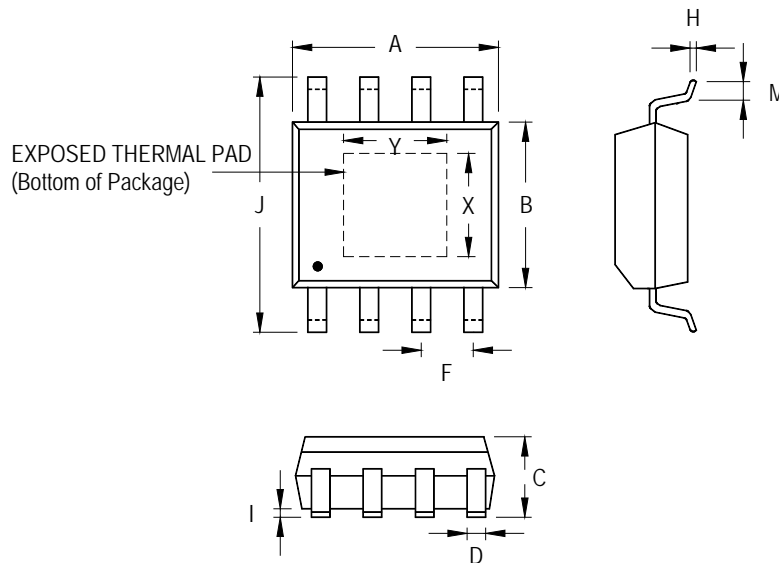

Symbol	Dimensions In Millimeters		Dimensions In Inches		
	Min	Max	Min	Max	
A	4.801	5.004	0.189	0.197	
B	3.810	4.000	0.150	0.157	
C	1.346	1.753	0.053	0.069	
D	0.330	0.510	0.013	0.020	
F	1.194	1.346	0.047	0.053	
H	0.170	0.254	0.007	0.010	
I	0.000	0.152	0.000	0.006	
J	5.791	6.200	0.228	0.244	
M	0.406	1.270	0.016	0.050	
Option 1	X	2.000	2.300	0.079	0.091
	Y	2.000	2.300	0.079	0.091
Option 2	X	2.100	2.500	0.083	0.098
	Y	3.000	3.500	0.118	0.138

8-Lead SOP (Exposed Pad) Plastic Package

Richtek Technology Corporation

Headquarter
 5F, No. 20, Taiyuen Street, Chupei City
 Hsinchu, Taiwan, R.O.C.
 Tel: (8863)5526789 Fax: (8863)5526611

Richtek Technology Corporation

Taipei Office (Marketing)
 8F, No. 137, Lane 235, Paochiao Road, Hsintien City
 Taipei County, Taiwan, R.O.C.
 Tel: (8862)89191466 Fax: (8862)89191465
 Email: marketing@richtek.com