



---

## CHT-LD-100

*Preliminary datasheet  
Version 0.0 (09/2004)*

### High-Temperature, 10V, 1A, Low-Dropout SOI-CMOS Voltage Regulator.

---

#### General Description

The CHT-LD-100 is a 1A, low-dropout linear voltage regulator compatible with high-temperature environments. Typical operation temperature range extends from -30°C to 225°C.

The circuit is stable throughout the whole temperature range and with a large choice of capacitive loads.

The minimum dropout voltage is 2V with a 1A load and 1V for load currents lower than 100mA. The input voltage may span from 11 Volts to 25 Volts.

The circuit is a one-die solution.

CHT-LD-100 is available in die and packages (currently TO-3 and TO-220) on demand.

#### Applications

Power supplies for high-temperature electronic systems used in Well logging, Automotive, Aeronautics or Aerospace applications.

#### Features

- 11V to 25V input Voltage @100mA
- 12V to 25V input Voltage @1A
- Max 1A output current @ 225°C
- 60dB input ripple rejection (0-100Hz)
- $C_{load}$  from 100nF to 1000 $\mu$ F, large ESR range
- Available on die or in custom package on demand. (3-pins compatible)
- Stand-by mode available. (4-pins)
- Tungsten interconnects for long-term reliability
- The start-up is operative over the whole temperature range
- Latch-up free

---

#### Typical application

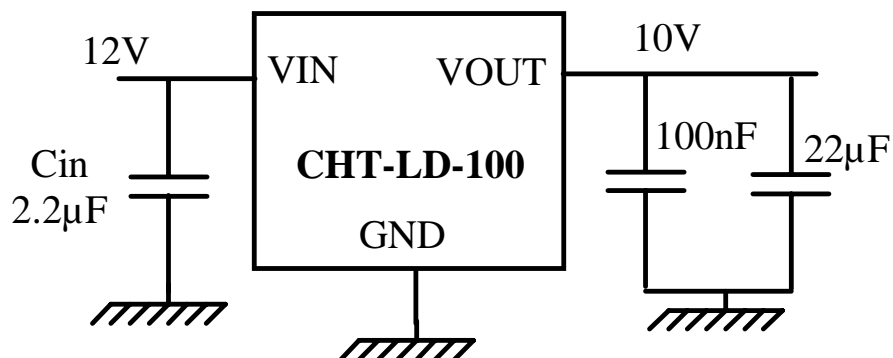

### Absolute Maximum Ratings

Supply Voltage  $V_{in}$  40V  
 Junction Temperature<sup>(1)</sup> ( $T_j$ ) 315°C  
 Power dissipation<sup>(2)</sup>

### Operating Conditions

Supply Voltage 11V to 25V  
 Junction temperature -30°C to 225°C  
 Power Dissipation<sup>(2)</sup>

### ESD Rating (expected)

Human Body Model >1kV

## Electrical Characteristics

$V_{in} = V_{out} + 2V$ ,  $T = 25^\circ C$  (unless otherwise stated)

Parameter	Condition	Min	Typ	Max	Units
Output voltage accuracy	$I_L = 10mA$	9.9 -1	10	10.1 1	V %
Output voltage accuracy	$I_L = 10mA$ $-30^\circ C < T_j < 225^\circ C$	9.8 -2	10	12.2 2	V %
Output voltage line regulation	$V_{in} = V_{out} + 2V$ to $V_{out} + 15V$ $I_L = 60mA$ , $-30^\circ C < T_j < 225^\circ C$	-1		1	mV/V
Output voltage load regulation (i.e. $R_{out}$ )	$I_L = 10mA$ to 1A $V_{in} = V_{out} + 2V$ $-30^\circ C < T_j < 225^\circ C$		0.05	0.1	V/A
(Vin-Vout) (drouput)	$I_L = 100mA$ , $-30^\circ C < T_j < 225^\circ C$	1			V
	$I_L = 1A$ , $-30^\circ C < T_j < 225^\circ C$	2			V
Quiescent Ground Pin current	$0 < I_L < 1A$ $T_j = -30^\circ C$ $T_j = 225^\circ C$			10 9.5	mA
Power supply rejection ratio	$f = 0Hz \dots 200Hz$ $I_{load} = 100mA$	>60			dB
Foldback current				tbd	A
Short-circuit current	$20^\circ C < T_j < 225^\circ C$ $T_j = -20^\circ C$			tbd tbd	mA
Output noise	10Hz-10kHz $I_L = 100mA$ , $-30^\circ C < T_j < 225^\circ C$		200		$\mu V_{RMS}$

#### Notes:

(1) Above 225°C, a minimum load current of few mA (<10 mA) could be required.

(2) Power dissipation depends on packaging. For a package with  $5^\circ C/W$  ( $R_{th}$ ),  
 $P_{max} = (\text{Max junction temperature} - \text{Environment temperature}) / R_{th}$ .

---

## Output Load, recommended specifications

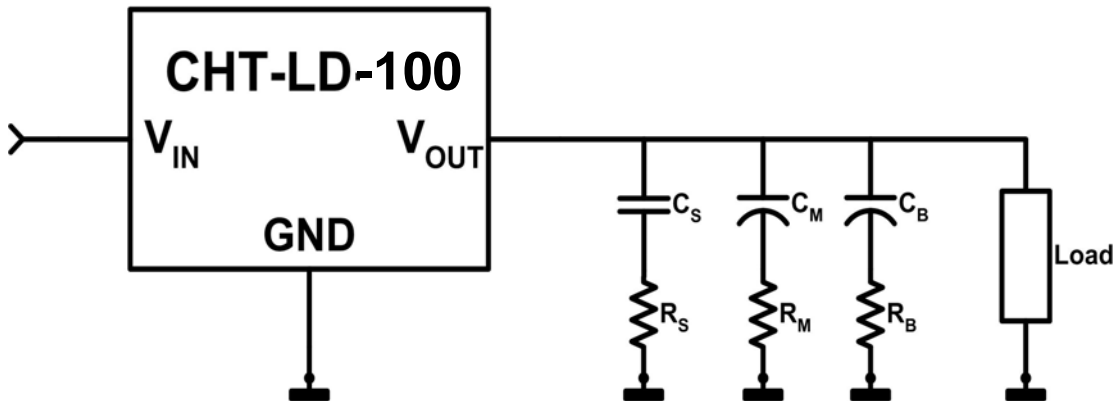

Resistances in series with capacitors represent the internal ESR of these capacitors.

For large capacitors:

$C_B = 0$  to  $1000\mu\text{F}$

$R_B = 0.2$  to  $\infty \Omega$

For medium capacitors:

$C_M = 0$  to  $6\mu\text{F}$

$R_M = 0.1$  to  $1 \Omega$

For small Capacitors:

$C_S = 100\text{n}$  to  $220\text{nF}$

$R_S = 10\text{m}$  to  $50\text{m} \Omega$

---

## Fast load current transients

tbd

---

## Contact & Ordering

CISSOID S.A.  
 Chemin du cyclotron, 6  
 1348 Louvain-la-Neuve  
 Belgium

Tel : +3210489210

Fax : +3210489219

[sales@cissoid.com](mailto:sales@cissoid.com)

<http://www.cissoid.com>

## Disclaimer

*Neither CISSOID, nor any of its directors, employees or affiliates make any representations or extend any warranties of any kind, either express or implied, including but not limited to warranties of merchantability, fitness for a particular purpose, and the absence of latent or other defects, whether or not discoverable. In no event shall CISSOID, its directors, employees and affiliates be liable for direct, indirect, special, incidental or consequential damages of any kind arising out of the use of its circuits and their documentation, even if they have been advised of the possibility of such a damage. The circuits are provided "as is". CISSOID has no obligation to provide maintenance, support, updates, or modifications.*