

## ■ General Description

The AME8820 family of positive, linear regulators feature low quiescent current (30 $\mu$ A typ.) low dropout voltage and excellent PSRR, thus making them ideal for Telecommunications and other battery applications. The ultra-small CSP package is attractive for "Pocket" and "Hand Held" applications.

These rugged devices have both Thermal Shutdown, and Current limit to prevent device failure under the Worst operating conditions.

The AME8820 is stable with an output capacitance of 1 $\mu$ F or larger.

## ■ Features

- Very Low Dropout Voltage
- Guaranteed 150mA Output
- Accurate to within 1.0%
- 30 $\mu$ A Quiescent Current
- Over-Temperature Shutdown
- Current Limiting
- Excellent PSRR (Typ. 65dB)
- Power-Saving Shutdown Mode
- Ultra-Small CSP Packages
- Factory Pre-set Output Voltages
- Low Temperature Coefficient
- Input Voltage Range (2.5V - 5.5V)
- All AME's Lead Free Products Meet RoHS Standards.

## ■ Applications

- Cellular Phones
- Instrumentation
- Portable Electronics
- Wireless Devices
- Cordless Phones
- PC Peripherals
- Battery Powered Widgets
- Cameras
- Telecommunications

## ■ Functional Block Diagram

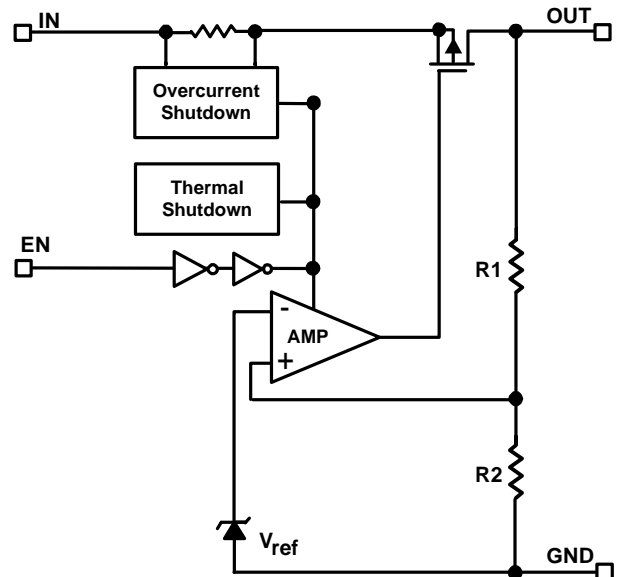

## ■ Typical Application

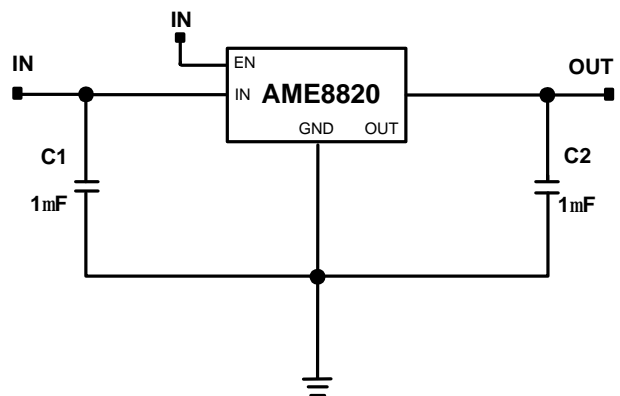

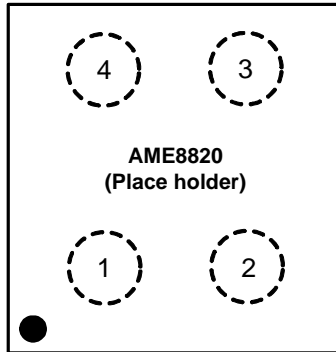
**■ Pin Configuration**
**CSP-4 (4Bumps)  
Top View**

**AME8820AENU**

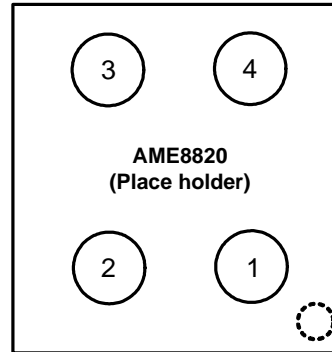
1. EN
2. IN
3. OUT
4. GND

**CSP-4 (4Bumps)  
Bottom View**

**■ Pin Description**

Pin Number	Pin Name	Pin Description
1	EN	Enable pin. When pulled low, the PMOS pass transistor turns off, current consuming less than 1 $\mu$ A.
2	IN	Input voltage pin. It should be decoupled with 1 $\mu$ F or greater capacitor.
3	OUT	LDO voltage regulator output pin. It should be decoupled with a 1 $\mu$ F or greater value low ESR ceramic capacitor.
4	GND	Ground connection pin.

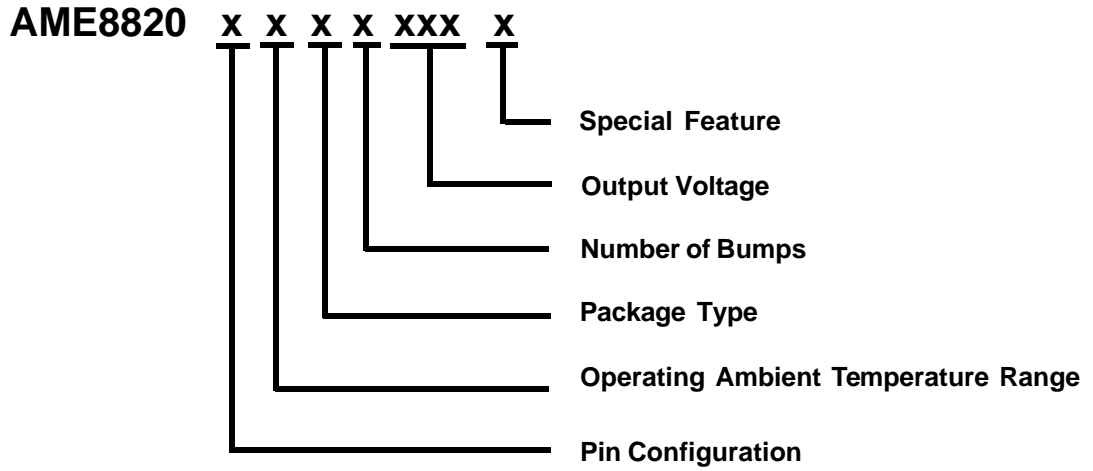

■ Ordering Information



Pin Configuration	Operating Ambient Temperature Range	Package Type	Number of Bumps	Output Voltage	Special Feature
A: 1. EN (CSP) 2. IN (4Bumps) 3. OUT 4. GND	E: -40°C to 85°C	N: CSP	U: 4	120: V=1.2V 130: V=1.3V 150: V=1.5V 180: V=1.8V 200: V=2.0V 250: V=2.5V 280: V=2.8V 285: V=2.85V 300: V=3.0V 330: V=3.3V	Z: Lead free

**■ Ordering Information**

Part Number	Marking*	Output Voltage	Package	Operating Ambient Temperature Range
AME8820AENU120Z	Aw	1.2V	CSP-4 (4 Bumps)	- 40°C to 85°C
AME8820AENU130Z	lw	1.3V	CSP-4 (4 Bumps)	- 40°C to 85°C
AME8820AENU150Z	Bw	1.5V	CSP-4 (4 Bumps)	- 40°C to 85°C
AME8820AENU180Z	Cw	1.8V	CSP-4 (4 Bumps)	- 40°C to 85°C
AME8820AENU200Z	Ew	2.0V	CSP-4 (4 Bumps)	- 40°C to 85°C
AME8820AENU250Z	Fw	2.5V	CSP-4 (4 Bumps)	- 40°C to 85°C
AME8820AENU280Z	Gw	2.8V	CSP-4 (4 Bumps)	- 40°C to 85°C
AME8820AENU285Z	Jw	2.85V	CSP-4 (4 Bumps)	- 40°C to 85°C
AME8820AENU300Z	Hw	3.0V	CSP-4 (4 Bumps)	- 40°C to 85°C
AME8820AENU330Z	Dw	3.3V	CSP-4 (4 Bumps)	- 40°C to 85°C

Note: w represent the date code and pls refer to Date Code Rule page on Package Dimension.

\* A circle on top represents Pin1 & CSP 4Bumps package.

Please consult AME sales office or authorized Rep./Distributor for the availability of package type.



■ Absolute Maximum Ratings

Parameter	Maximum	Unit
Input Voltage	6	V
Output Current	$P_D / (V_{IN} - V_{OUT})$	mA
Output Voltage	GND - 0.3 to $V_{IN} + 0.3$	V
ESD Classification	B*	

Caution: Stress above the listed absolute maximum rating may cause permanent damage to the device

\* HBM B: 2000V ~ 3999V

■ Recommended Operating Conditions

Parameter	Symbol	Rating	Unit
Ambient Temperature Range	$T_A$	- 40 to 85	°C
Junction Temperature Range	$T_J$	- 40 to 125	°C
Storage Temperature Range	$T_{STG}$	- 65 to 150	°C

■ Thermal Information

Parameter	Package	Die Attach	Symbol	Maximum	Unit
Thermal Resistance (Junction to Ambient)	CSP-4 (4 Bumps)	Conductive Epoxy	$\theta_{JA}$	360	°C / W
Internal Power Dissipation			$P_D$	400	mW
Solder Iron (10 Sec)*				350	°C

\* MIL-STD-202G 210F

**■ Electrical Specifications**
 $V_{IN} = V_{OUT(Typ)} + 1V$ ,  $I_{OUT} = 1mA$ ,  $V_{EN} = V_{IN}$ ,  $T_J = -40^{\circ}C$  to  $125^{\circ}C$ ,  $C_{IN} = C_{OUT} = 1\mu F$ , unless otherwise noted

Parameter	Symbol	Test Condition	Min	Typ	Max	Units	
Input Voltage	$V_{IN}$		2.5		5.5	V	
Output Voltage Accuracy	$V_{OUT}$	$I_{OUT} = 1mA$ , $T_A = 25^{\circ}C$	-1.5		1.5	%	
		$I_{OUT} = 1mA$ , $T_J = -40^{\circ}C$ to $125^{\circ}C$	-3		3		
Dropout Voltage	$V_{DROPOUT}$	$I_{OUT} = 150mA$ $V_{OUT} = V_{OUT(Typ)} - 2\%^*$ $V_{OUT(Typ)}$ $T_A = 25^{\circ}C$	$V_{OUT(Typ)} = 3.3V$		125	200	mV
			$V_{OUT(Typ)} = 3.0V$		140	210	
			$V_{OUT(Typ)} = 2.85V$		150	230	
			$V_{OUT(Typ)} = 2.8V$		150	230	
			$V_{OUT(Typ)} = 2.5V$		180	250	
			$V_{OUT(Typ)} = 2.0V$			500	
			$V_{OUT(Typ)} < 2.0V$	$V_{IN(min)} = 2.5V$			
Current Limit	$I_{LIM}$	$V_{OUT} = 0.9 V_{OUT(Typ)}$		400	600	mA	
Short Circuit Current	$I_{SC}$	$V_{OUT} = 0V$		200		mA	
Quiescent Current	$I_Q$	$1mA \leq I_{OUT} \leq 150mA$		30	50	$\mu A$	
Line Regulation (See Note 1)	$REG_{LINE}$	$V_{OUT} > 1.8V$ $V_{IN} = V_{OUT} + 0.5V$ to $5.5V$	$T_A = 25^{\circ}C$	-0.25	0.1	0.25	%V
			$T_J = -40^{\circ}C$ to $125^{\circ}C$	-0.4		0.4	
		$1.2V \leq V_{OUT} \leq 1.8V$ $V_{IN} = 2.5V$ to $5.5V$	$T_A = 25^{\circ}C$	-0.6	0.3	0.6	
			$T_J = -40^{\circ}C$ to $125^{\circ}C$	-1.0		1.0	
Load Regulation (See Note 2)	$REG_{LOAD}$	$V_{OUT} \geq 2.5V$ $V_{IN} = V_{OUT} + 1V$ $I_{OUT} = 1mA$ to $150mA$	$T_A = 25^{\circ}C$	-0.02	0.001	0.02	%mA
			$T_J = -40^{\circ}C$ to $125^{\circ}C$	-0.03		0.03	
		$1.8V < V_{OUT} < 2.5V$ $V_{IN} = V_{OUT} + 1V$ $I_{OUT} = 1mA$ to $150mA$	$T_A = 25^{\circ}C$	-0.03	0.002	0.03	
			$T_J = -40^{\circ}C$ to $125^{\circ}C$	-0.04		0.04	
		$1.2V \leq V_{OUT} \leq 1.8V$ $V_{IN} = 2.5V$ $I_{OUT} = 1mA$ to $150mA$	$T_A = 25^{\circ}C$	-0.04	0.015	0.04	
			$T_J = -40^{\circ}C$ to $125^{\circ}C$	-0.05		0.05	
Over Temperature Shutdown	OTS			150		$^{\circ}C$	
Over Temperature Hysteresis	OTH			25		$^{\circ}C$	



■ Electrical Specifications

Parameter	Symbol	Test Condition	Min	Typ	Max	Units
V <sub>OUT</sub> Temperature Coefficient	TC	I <sub>OUT</sub> = 1mA V <sub>OUT</sub> > 1.8V V <sub>IN</sub> = V <sub>OUT</sub> + 1V 1.2V ≤ V <sub>OUT</sub> ≤ 1.8V V <sub>IN</sub> = 2.5V		30		ppm/°C
Power Supply Rejection	PSRR	I <sub>OUT</sub> = 100mA, C <sub>OUT</sub> = 4.7μF, Freq. = 1KHz	V <sub>OUT</sub> ≥ 2.5 V <sub>IN</sub> = V <sub>OUT</sub> + 1V		65	dB
			1.8V ≤ V <sub>OUT</sub> < 2.5V V <sub>IN</sub> = V <sub>OUT</sub> + 1V		60	
			1.2V ≤ V <sub>OUT</sub> < 1.8V V <sub>IN</sub> = 2.5V		65	
Enable Input Threshold Voltage	V <sub>ENH</sub>	2.5V ≤ V <sub>IN</sub> ≤ 5.5V	1.4			V
	V <sub>ENL</sub>				0.3	V
Enable Input Bias Current	I <sub>EN</sub>	V <sub>IN</sub> = 5V, EN = 0V or 5V		0.1	1	μA
Shutdown Supply Current	I <sub>SD</sub>	V <sub>IN</sub> = 5V, V <sub>EN</sub> = 0V		0.5	1	μA

$$\text{Note 1: Line Regulation} = \frac{\frac{\Delta V_{out}}{\Delta V_{in}} \times 100\%}{V_{out}}$$

$$\text{Note 2: Load Regulation} = \frac{\frac{\Delta V_{out}}{V_{out}} \times 100\%}{\Delta I(mA)}$$



## ■ Detailed Description

The AME8820 family of CMOS regulators contain a PMOS pass transistor, voltage reference, error amplifier, over-current protection, and thermal shutdown.

The P-channel pass transistor receives data from the error amplifier, over-current shutdown, and thermal protection circuits. During normal operation, the error amplifier compares the output voltage to a precision reference. Over-current and thermal shutdown circuits become active when the junction temperature exceeds 150°C, or the current exceeds 150mA. During thermal shutdown, the output voltage remains low. Normal operation is restored when the junction temperature drops below 125°C.

The AME8820 switches from voltage mode to current mode when the load exceeds the rated output current. This prevents over-stress.

## ■ External Capacitors

The AME8820 is stable with an output capacitor to ground of 1 $\mu$ F or larger. Ceramic capacitors have the lowest ESR, and will offer the best AC performance. Conversely, Aluminum Electrolytic capacitors exhibit the highest ESR, resulting in the poorest AC response.

A second capacitor is recommended between the input and ground to stabilize  $V_{IN}$ . The input capacitor should be at least 1 $\mu$ F to have a beneficial effect.

## ■ Enable

The Enable Pin is normally pull-high. When disabled, it pulled low, the PMOS pass transistor shut off. All internal circuits are power down. Under this circumstance, the standby current is less than 1 $\mu$ A. This pin can't be floating.

## ■ Board layout Recommendations to Improve PSRR and Output Noise

To improve AC measurements like transient response, PSRR, and output noise, it is recommended that the board should be designed with separate ground planes for  $V_{IN}$  and  $V_{OUT}$ , with each ground plane connected only at the ground pin of the device.

## ■ Over Current Protection and Short circuit Protection

During normal operation, the AME8820 limits output current to approximately 400mA. When current limiting engages, the output voltage scales back linearly until the overcurrent condition ends.

When the output voltage is lower than approximately 0.8V, call short circuit, the AME8820 limits output current to approximately 200mA (fold back current). When short circuit protection engages, regulator operation resumes until removed the short circuit condition. Over current and short circuit protection prevent gross device failure, care should be taken not to exceed the power dissipation ratings of the package



## ■ Over Temperature Protection

As protection from damage due to excessive junction temperatures, the AME8820 has internal protection circuit. When junction temperature reaches approximately 150°C, the output device is turned off. Once the device has cooled down to below approximately 125°C, regulator operation resumes.

For reliable operation, design is for worst case junction temperature of  $\leq 125^{\circ}\text{C}$  taking into account worst case ambient temperature and load conditions. Depending on each package type, presenting different power dissipation, thermal resistance, and ambient temperature, the thermal protection circuit may cycle on and off. This cycling limits the dissipation of the regulator, protecting it from damage due to overheating.

Any tendency to activate the thermal protection circuit indicates excessive power dissipation or inadequate heatsink. For reliable operation, junction temperature should be limited to +125°C maximum. To estimate the margin of safety in a complete Power design (including heatsink), increase the ambient temperature until the thermal protection is triggered; use worst-case loads and signal conditions. For good reliability, thermal protection should trigger at least +35°C above the maximum expected ambient condition of your particular application. This configuration produces a worst-case junction temperature of +125°C at the highest expected ambient temperature and worst-case load. The internal protection circuitry of the AME8820 has designed to protect against overload conditions. It was not intended to replace proper heatsinking. Continuously running the AME8820 into Thermal protection disables the output when the thermal shutdown will degrade device reliability.

Using equation (1) and (2) to calculate  $T_J$ :

$$T_J = T_A + (P_D \times R_{qJA}) \quad (1)$$

$$P_D = (V_{IN} - V_{OUT}) \times I_{OUT} + V_{IN} \times I_Q \quad (2)$$

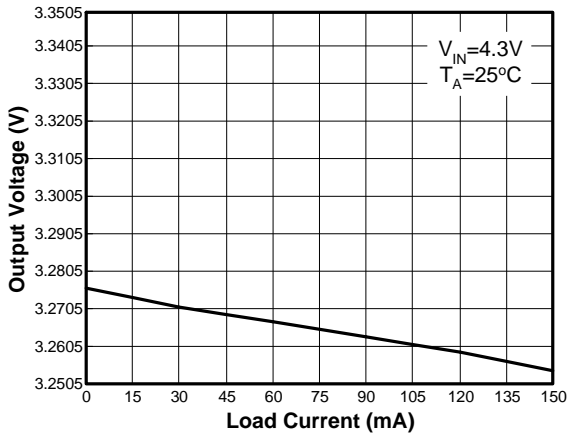
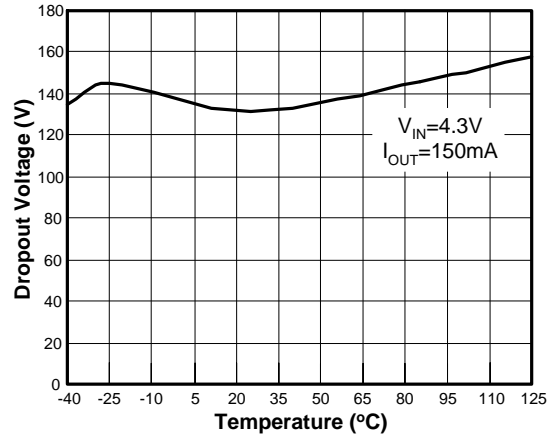
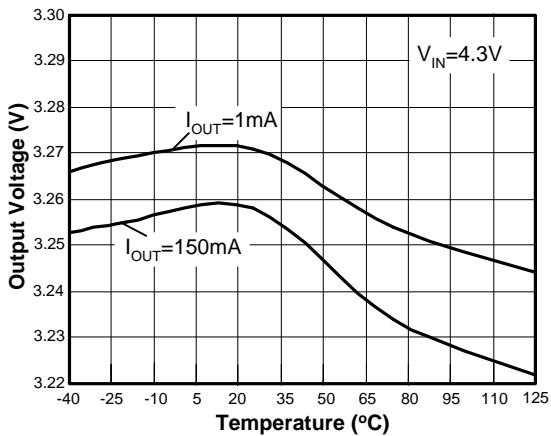
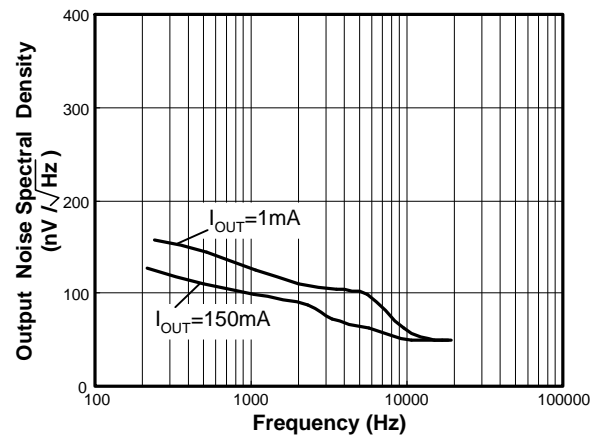
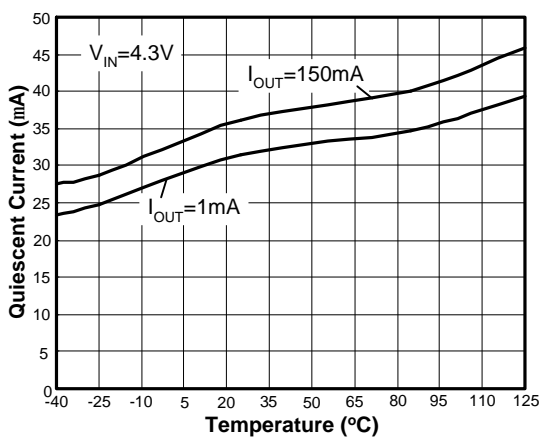
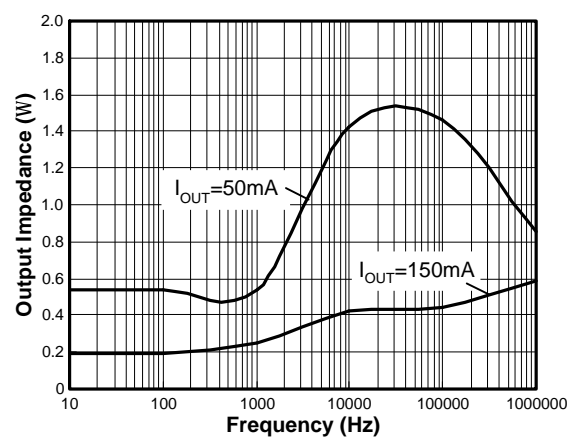
**Output Voltage vs Load Current**

**Dropout Voltage vs Temperature**

**Output Voltage vs Temperature**

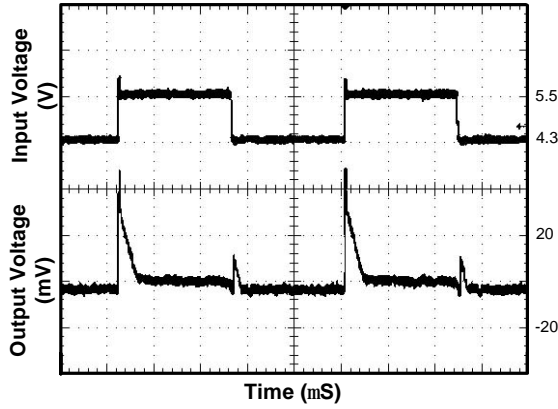
**Output Noise Spectral Density**

**Quiescent Current vs Temperature**

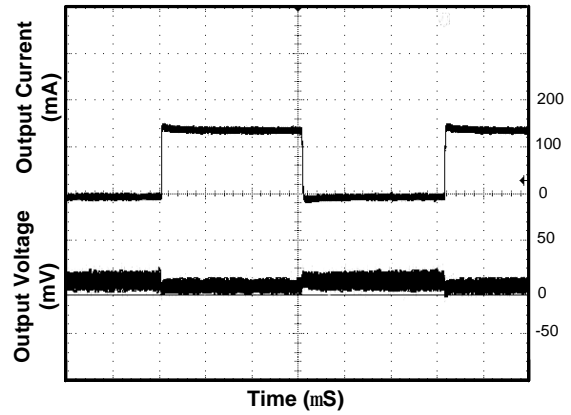
**Output Impedance vs Frequency**



Line Transient Response



Load Transient Response



Power Supply Ripple Rejection

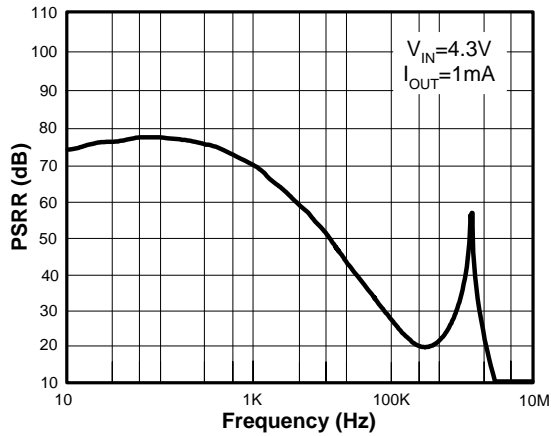

Power Supply Ripple Rejection

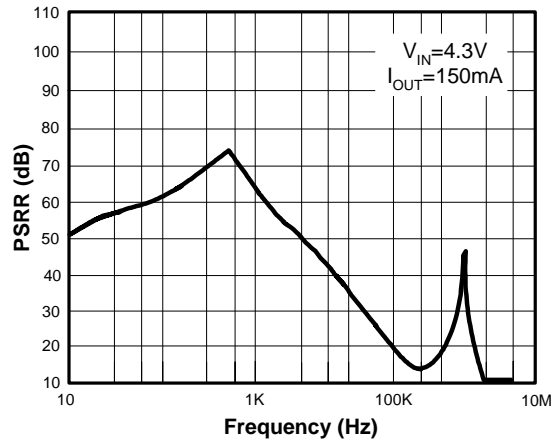

Rising Time

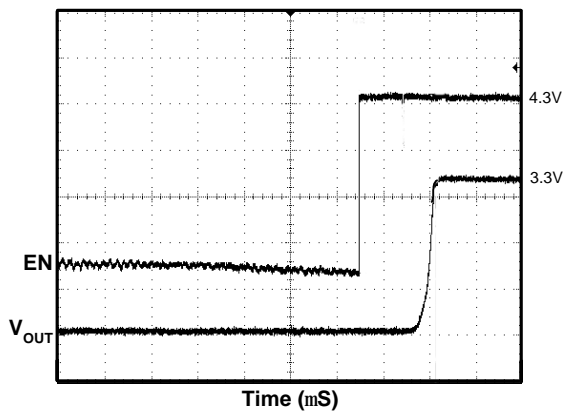

**■ Date Code Rule**

w: Work Week Code					
A:	01&02	K:	21&22	U:	41&42
B:	03&04	L:	23&24	V:	43&44
C:	05&06	M:	25&26	W:	45&46
D:	07&08	N:	27&28	X:	47&48
E:	09&10	O:	29&30	Y:	49&50
F:	11&12	P:	31&32	Z:	51&52
G:	13&14	Q:	33&34		
H:	15&16	R:	35&36		
I:	17&18	S:	37&38		
J:	19&20	T:	39&40		

— :Year Code		
xxx0	W	W
xxx1	W	$\overline{W}$
xxx2	W	$\underline{W}$
xxx3	W	$\overline{\overline{W}}$
xxx4	$\overline{W}$	W
xxx5	$\overline{\overline{W}}$	$\overline{W}$
xxx6	$\overline{\overline{\overline{W}}}$	$\underline{W}$
xxx7	$\overline{W}$	$\overline{\overline{W}}$
xxx8	$\underline{W}$	W
xxx9	$\underline{\overline{W}}$	$\overline{\overline{W}}$

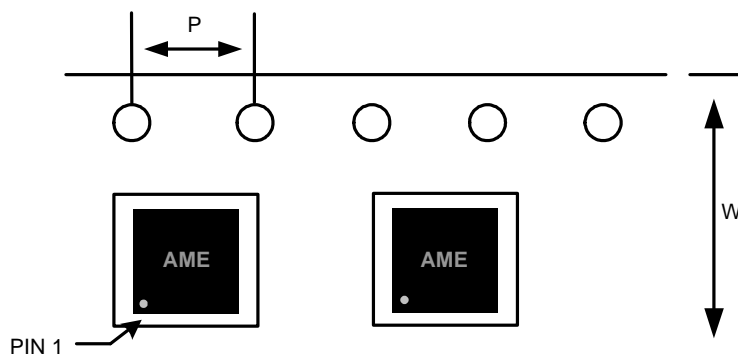
**■ Tape & Reel Dimension**
**CSP-4 (4Bumps)**

**Carrier Tape, Number of Components Per Reel and Reel Size**

Package	Carrier Width (W)	Pitch (P)	Part Per Full Reel	Reel Size
CSP-4 (4Bumps)	8.0 $\begin{smallmatrix} +0.3 \\ -0.1 \end{smallmatrix}$ mm	4.0 $\pm$ 0.1 mm	3000pcs	180 $\pm$ 1 mm



■ Package Dimension

CSP-4 (4Bumps)

Bottom View

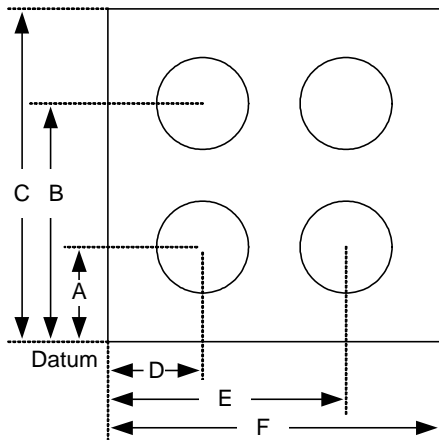

SYMBOLS	MILLIMETERS		INCHES	
	MIN	MAX	MIN	MAX
A	0.310	0.350	0.012	0.014
B	0.810	0.850	0.032	0.033
C	1.060	1.260	0.042	0.050
D	0.310	0.350	0.012	0.014
E	0.810	0.850	0.032	0.033
F	1.060	1.260	0.042	0.050
G	0.020	0.050	0.001	0.002
H	0.380	0.450	0.015	0.018
I	0.595	0.705	0.023	0.028
J	0.300	0.340	0.012	0.013

Side View

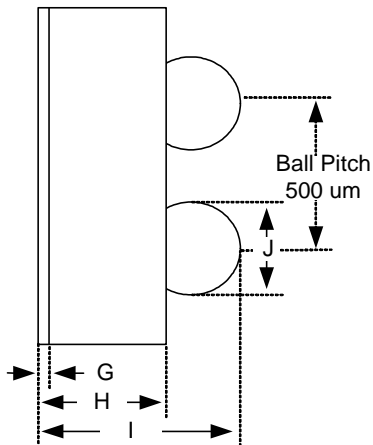



**www.ame.com.tw**  
**E-Mail: sales@ame.com.tw**

**Life Support Policy:**

These products of AME, Inc. are not authorized for use as critical components in life-support devices or systems, without the express written approval of the president of AME, Inc.

AME, Inc. reserves the right to make changes in the circuitry and specifications of its devices and advises its customers to obtain the latest version of relevant information.

© AME, Inc. , June 2007

Document: 1041-DS8820-B.01

**Corporate Headquarter**  
**AME, Inc.**

2F, 302 Rui-Guang Road, Nei-Hu District  
Taipei 114, Taiwan.  
Tel: 886 2 2627-8687  
Fax: 886 2 2659-2989

**U.S.A.(Subsidiary)**  
**Analog Microelectronics, Inc.**

3100 De La Cruz Blvd., Suite 201  
Santa Clara, CA. 95054-2438  
Tel : (408) 988-2388  
Fax: (408) 988-2489