

GSD

KN-59-263-M07

REVISIONS

ISSUE	CHANGES
1	CN 33219 C JCA 08/16/91
2	CN 39511 C DRK 06/30/06

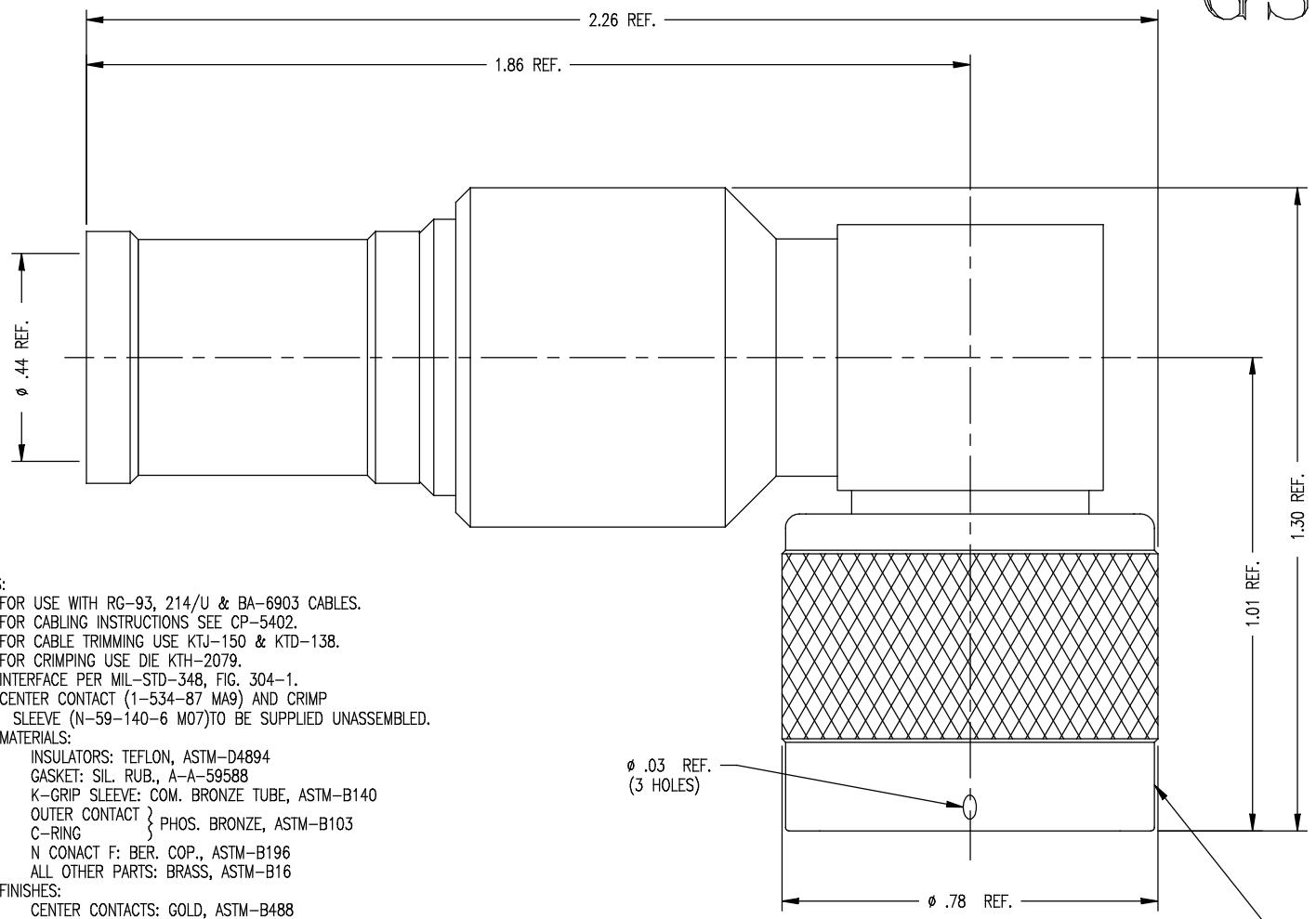

NOTES:

- FOR USE WITH RG-93, 214/U & BA-6903 CABLES.
- FOR CABLING INSTRUCTIONS SEE CP-5402.
- FOR CABLE TRIMMING USE KTJ-150 & KTD-138.
- FOR CRIMPING USE DIE KTH-2079.
- INTERFACE PER MIL-STD-348, FIG. 304-1.
- CENTER CONTACT (1-534-87 MA9) AND CRIMP SLEEVE (N-59-140-6 M07) TO BE SUPPLIED UNASSEMBLED.
- MATERIALS:
  - INSULATORS: TEFLON, ASTM-D4894
  - GASKET: SIL. RUB., A-A-59588
  - K-GRIP SLEEVE: COM. BRONZE TUBE, ASTM-B140
  - OUTER CONTACT } PHOS. BRONZE, ASTM-B103
  - C-RING }
  - N CONTACT F: BER. COP., ASTM-B196
  - ALL OTHER PARTS: BRASS, ASTM-B16
- FINISHES:
  - CENTER CONTACTS: GOLD, ASTM-B488
  - ALL OTHER METAL PARTS: SILVER, ASTM-B700
- ELECTRICAL CHARACTERISTICS:
  - NOMINAL IMPEDANCE: 50 OHMS
  - VOLTAGE RATING: 1000 VRMS
  - FREQUENCY RANGE: DC TO 11 GHz

SCALE	4:1		
APPROX SURFACE AREA			
USED ON			
REF:			
PLUG, ANGLE, N			
DRAWN	JCA	DATE	12/21/92
DESIGN	MJB	DATE	12/22/92
APPR.		DATE	
 <b>KINGS</b> ELECTRONICS CO., INC. ROCK HILL, SOUTH CAROLINA 29730			

KN-59-263-M07

GSD