

IN74HCU04A

Hex Unbuffered Inverters
High-Performance Silicon-Gate CMOS

The IN74HCU04A is identical in pinout to the 74LS04. This contains six independent unbuffered inverters. These inverters are well suited for use as oscillators, pulse shapers and in many other applications requiring a high-input impedance amplifier.

This device is characterized for over wide temperature ranges to meet industry and military specifications.

- Low Power consumption characteristic of CMOS devices
- Output drive capability: 10 LS TTL Loads Min.
- Operating speed superior to LS TTL
- Wide operating voltage range: 2.0 to 6.0 V
- Low input current: 1.0 μ A Max.
- Low quiescent current: 20 μ A Max.
- High noise immunity characteristic of CMOS
- Diode protection on all inputs

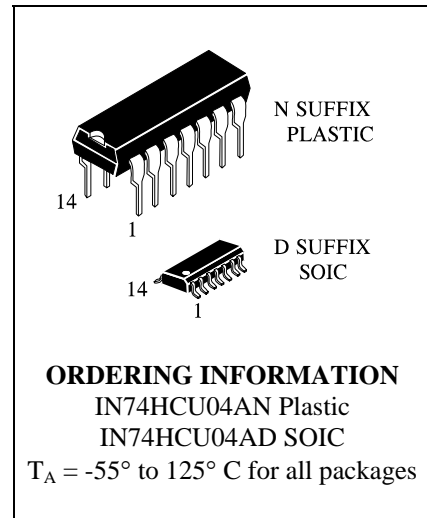

LOGIC DIAGRAM

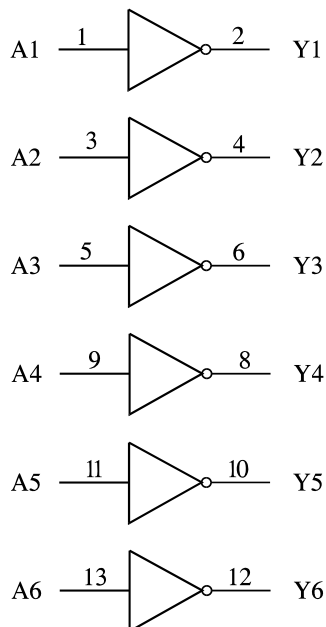

PIN 14 = V_{CC}
 PIN 7 = GND

PIN ASSIGNMENT

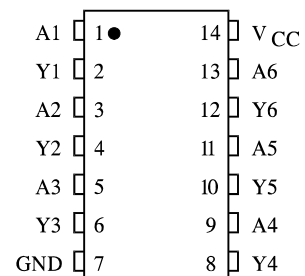

FUNCTION TABLE

Inputs	Output
A	Y
L	H
H	L

MAXIMUM RATINGS*

Symbol	Parameter	Value	Unit
V _{CC}	DC Supply Voltage (Referenced to GND)	-0.5 to +7.0	V
V _{IN}	DC Input Voltage (Referenced to GND)	-1.5 to V _{CC} +1.5	V
V _{OUT}	DC Output Voltage (Referenced to GND)	-0.5 to V _{CC} +0.5	V
I _{IN}	DC Input Current, per Pin	±20	mA
I _{OUT}	DC Output Current, per Pin	±25	mA
I _{CC}	DC Supply Current, V _{CC} and GND Pins	±50	mA
P _D	Power Dissipation in Still Air, Plastic DIP+ SOIC Package+	750 500	mW
T _{stg}	Storage Temperature	-65 to +150	°C
T _L	Lead Temperature, 1 mm from Case for 10 Seconds (Plastic DIP or SOIC Package)	260	°C

*Maximum Ratings are those values beyond which damage to the device may occur. Functional operation should be restricted to the Recommended Operating Conditions.

+Derating - Plastic DIP: - 10 mW/°C from 65° to 125°C
SOIC Package: : - 7 mW/°C from 65° to 125°C

RECOMMENDED OPERATING CONDITIONS

Symbol	Parameter	Min	Max	Unit
V _{CC}	DC Supply Voltage (Referenced to GND)	2.0	6.0	V
V _{IN} , V _{OUT}	DC Input Voltage, Output Voltage (Referenced to GND)	0	V _{CC}	V
T _A	Operating Temperature, All Package Types	-55	+125	°C
t _r , t _f	Input Rise and Fall Time (Figure 1)			
	V _{CC} =2.0 V	0	1000	ns
	V _{CC} =4.5 V	0	500	
	V _{CC} =6.0 V	0	400	

This device contains protection circuitry to guard against damage due to high static voltages or electric fields. However, precautions must be taken to avoid applications of any voltage higher than maximum rated voltages to this high-impedance circuit. For proper operation, V_{IN} and V_{OUT} should be constrained to the range GND≤(V_{IN} or V_{OUT})≤V_{CC}.

Unused inputs must always be tied to an appropriate logic voltage level (e.g., either GND or V_{CC}). Unused outputs must be left open.

DC ELECTRICAL CHARACTERISTICS (Voltages Referenced to GND)

Symbol	Parameter	Test Conditions	V _{CC} V	Guaranteed Limit			Unit
				25 °C to -55°C	≤85 °C	≤125 °C	
V _{IH}	Minimum High-Level Input Voltage		2.0	1.7	1.7	1.7	V
			4.5	3.6	3.6	3.6	
			6.0	4.8	4.8	4.8	
V _{IL}	Maximum Low - Level Input Voltage		2.0	0.3	0.3	0.3	V
			4.5	0.8	0.8	0.8	
			6.0	1.1	1.1	1.1	
V _{OH}	Minimum High-Level Output Voltage	V _{IN} =V _{IH} or V _{IL} I _{OH} = -20 μA	2.0	1.8	1.8	1.8	V
			4.5	4.0	4.0	4.0	
			6.0	5.5	5.5	5.5	
		V _{IN} =V _{IH} or V _{IL} I _{OH} = -4 mA I _{OH} = -5.2 mA	4.5	3.86	3.76	3.7	
			6.0	5.36	5.26	5.2	
V _{OL}	Maximum Low-Level Output Voltage	V _{IN} =V _{IH} or V _{IL} I _{OL} = 20 μA	2.0	0.2	0.2	0.2	V
			4.5	0.5	0.5	0.5	
			6.0	0.5	0.5	0.5	
		V _{IN} =V _{IH} or V _{IL} I _{OL} = 4 mA I _{OL} = 5.2 mA	4.5	0.32	0.37	0.4	
			6.0	0.32	0.37	0.4	
I _{IN}	Maximum Input Leakage Current	V _{IN} =V _{CC} or GND	6.0	±0.1	±1.0	±1.0	μA
I _{CC}	Maximum Quiescent Supply Current (per Package)	V _{IN} =V _{CC} or GND I _{OUT} =0 μA	6.0	2.0	20	40	μA

AC ELECTRICAL CHARACTERISTICS ($C_L=50\text{pF}$, Input $t_r=t_f=6.0\text{ ns}$)

Symbol	Parameter	V _{CC} V	Guaranteed Limit			Unit
			25 °C to -55°C	≤85°C	≤125°C	
t _{PLH} , t _{PHL}	Maximum Propagation Delay, Input A to Output Y (Figures 1 and 2)	2.0	80	100	120	ns
		4.5	16	20	24	
		6.0	14	17	20	
t _{TLH} , t _{THL}	Maximum Output Transition Time, Any Output (Figures 1 and 2)	2.0	75	95	110	ns
		4.5	15	19	22	
		6.0	13	16	19	
C _{IN}	Maximum Input Capacitance	-	10	10	10	pF

C _{PD}	Power Dissipation Capacitance (Per Inverter) Used to determine the no-load dynamic power consumption: $P_D=C_{PD}V_{CC}^2f+I_{CC}V_{CC}$	Typical @25°C, V _{CC} =5.0 V	pF
		15	

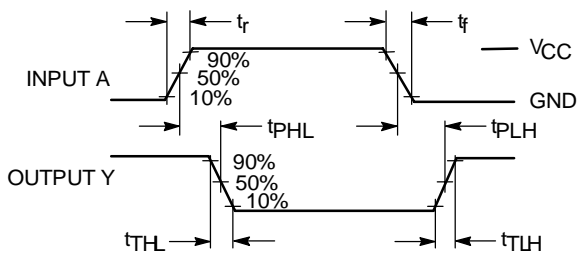
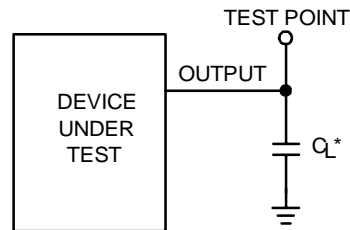

Figure 1. Switching Waveforms.



* Includes all probe and jig capacitance

Figure 2. Test Circuit

LOGIC DETAIL
(1/6 of Device Show)

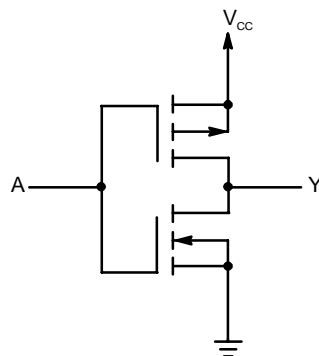

TYPICAL APPLICATIONS

Crystal Oscillator

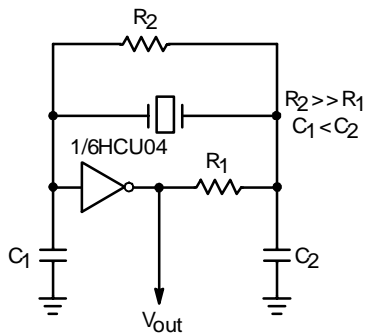

Stable RC Oscillator

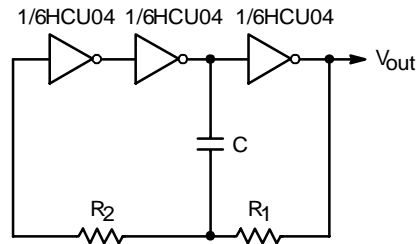

Schmitt Trigger

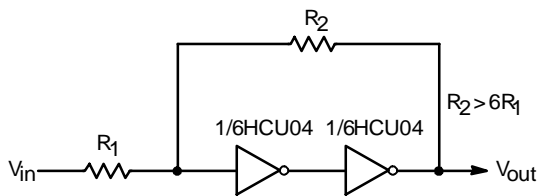

High Input Single-Stage Amplifier with a 2 to 6 V Supply Range

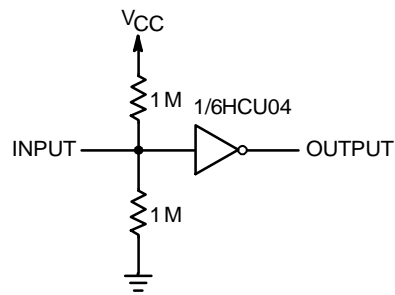

Multi-Stage Amplifier

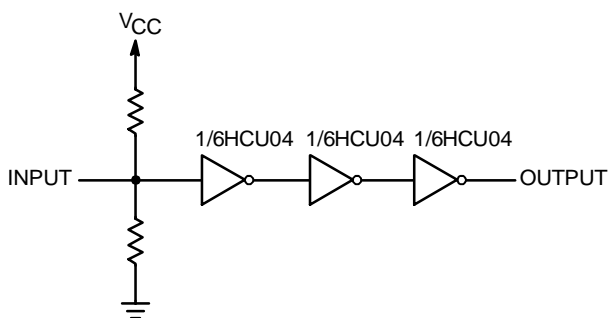

LED Driver

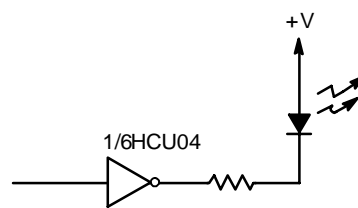

For reduced power supply current, use high-efficiency LEDs such as the Hewlett-Packard HLMP series or equivalent

**N SUFFIX PLASTIC DIP
(MS - 001AA)**

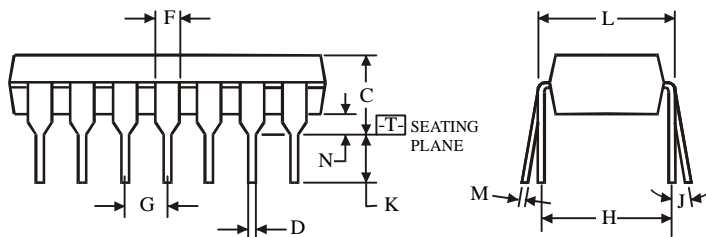
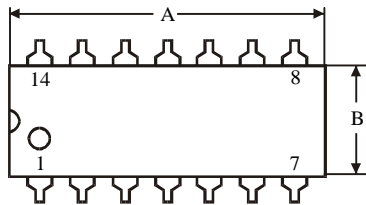
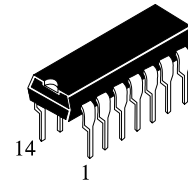

$\oplus 0.25 (0.010) \text{ (M) T}$

NOTES:

- Dimensions "A", "B" do not include mold flash or protrusions.
Maximum mold flash or protrusions 0.25 mm (0.010) per side.

Symbol	Dimension, mm	
	MIN	MAX
A	18.67	19.69
B	6.1	7.11
C		5.33
D	0.36	0.56
F	1.14	1.78
G	2.54	
H	7.62	
J	0°	10°
K	2.92	3.81
L	7.62	8.26
M	0.2	0.36
N	0.38	

**D SUFFIX SOIC
(MS - 012AB)**

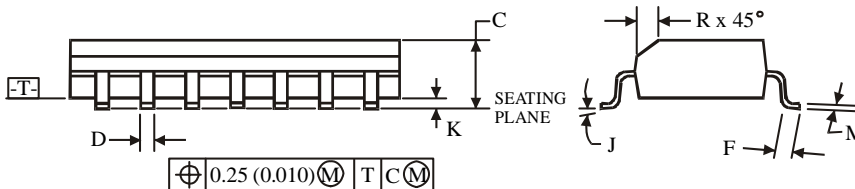
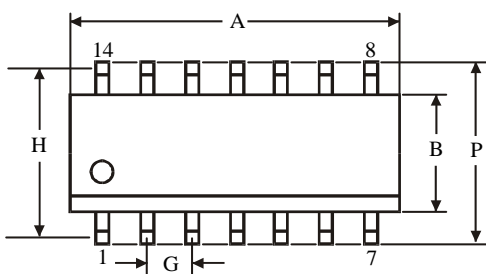
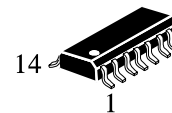

$\oplus 0.25 (0.010) \text{ (M) T C (M)}$

NOTES:

- Dimensions A and B do not include mold flash or protrusion.
- Maximum mold flash or protrusion 0.15 mm (0.006) per side for A; for B - 0.25 mm (0.010) per side.

Symbol	Dimension, mm	
	MIN	MAX
A	8.55	8.75
B	3.8	4
C	1.35	1.75
D	0.33	0.51
F	0.4	1.27
G	1.27	
H	5.27	
J	0°	8°
K	0.1	0.25
M	0.19	0.25
P	5.8	6.2
R	0.25	0.5