

GSD

M39012/17-0014

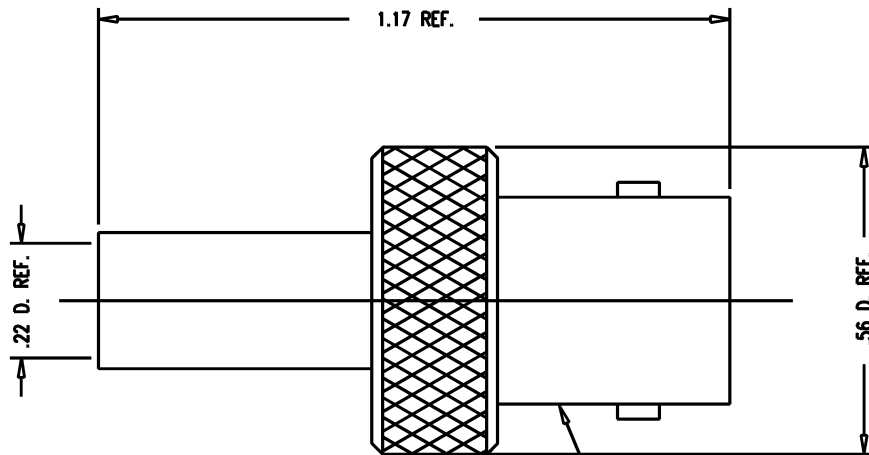

STAMP: 91836 M39012/17-0014
KC-39-93 XX XX (DATE CODE)

NOTES:

1. FOR USE WITH RG-142, 223 AND 400/U CABLE.
2. FOR CABLING INSTRUCTIONS SEE CP-465.
3. FOR CABLE TRIMMING USE KTJ-113 AND KTD-166.
4. FOR CRIMPING USE DIE KTH-2001.
5. INTERFACE PER MIL-STD-348, FIG. 301-2.
6. CENTER CONTACT TO BE SUPPLIED UNASSEMBLED.
7. MATERIALS:
 INSULATOR-TEFLON, ASTM-D-1457
 K-GRIP SLEEVE-COMMERCIAL BRONZE, ALLOY 220
 CENTER CONTACT-BER. COP., ASTM-B-196
 ALL OTHER METAL PARTS-BRASS, ASTM-B16
8. FINISHES:
 CENTER CONTACT-GOLD PLATE PER MIL-G-45204
 ALL OTHER METAL PARTS-SILVER PLATE PER QQ-S-365
9. ELECTRICAL CHARACTERISTICS:
 NOMINAL IMPEDANCE-50 OHMS
 FREQUENCY RANGE-DC TO 4 GHZ
 WORKING VOLTAGE-500 VRMS

REVISIONS

ISSUE	CHANGES
5	CN 32278 A LNM 06/13/90
6	CN 33690 C REDRAWN JCA 02/18/92
7	CN 33780 E JCA 03/01/93

KAM1161

SCALE 4:1	
APPROX SURFACE AREA	
KC-39-93	
USED ON	
REF:	
JACK, BNC	
DRAWN KH	DATE 05/31/91
DESIGN MJB	DATE 05/31/91
APPR.	DATE
KINGS ELECTRONICS CO., INC. TUCKAHOE, NEW YORK 10707	

M39012/17-0014

GSD