

■ FEATURES

- Peak Output Power : $\Phi_{ep} \geq 20$ W
- Peak Emission Wavelength : $870 \text{ nm} \pm 10 \text{ nm}$
- Emitting Area Size : $200 \mu\text{m} \times 1 \mu\text{m}$

■ APPLICATIONS

- Laser Range Finder
- Security



■ ABSOLUTE MAXIMUM RATINGS (Top(c) = 25 °C)

Parameter	Symbol	Value	Unit
Pulsed Forward Current	I_{fp}	25	A
Reverse Voltage	V_r	2	V
Pulse Duration	t_w	100	ns
Duty Ratio	DR	0.075	%
Operating Temperature	$T_{op(c)}$	-40 to +85	°C
Storage Temperature	T_{stg}	-40 to +100	°C

■ CHARACTERISTICS (Top(c) = 25 °C)

Parameter	Symbol	Conditions	Value			Unit	
			Min.	Typ.	Max.		
Pulsed Radiant Power (Peak Power)	Φ_{ep}	$I_{fp} = 20$ A	19	22	—	W	
Forward Voltage	V_f		—	7	—	V	
Peak Emission Wavelength	λ_p		860	870	880	nm	
Spectral Radiation Half Bandwidth	$\Delta\lambda$		—	4	—	nm	
Rise Time	t_r		—	—	2	ns	
Beam Spread Angle	Parallel	$\theta_{//}$	$I_{fp} = 20$ A FWHM	7	10	13	degree
	Vertical	θ_{\perp}		25	30	35	degree
Lasing Threshold Current	I_{th}	—	—	0.8	—	A	
Emitting Area Size	—	Value at designing	—	200×1	—	μm	

Note: General operating condition:

Pulse Width $t_w = 50$ ns, Repetition frequency $f_r = 1$ kHz

PULSED LASER DIODE L11649-120-04

Figure 1: Radiant Flux vs. Forward Current (Typ.)

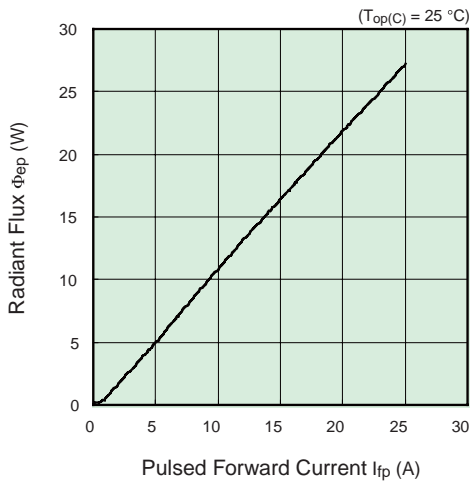

Figure 2: Emission Spectrum (Typ.)

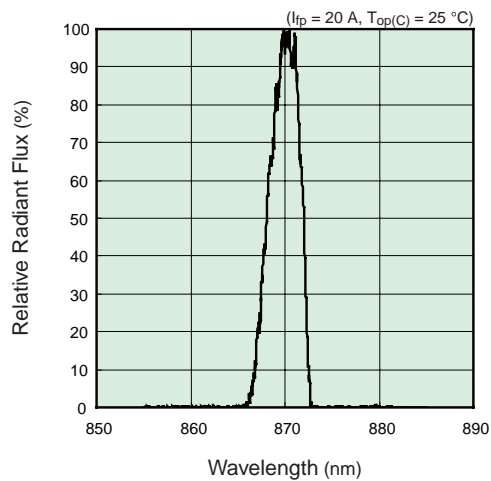

Figure 3: Directivity (Typ.)

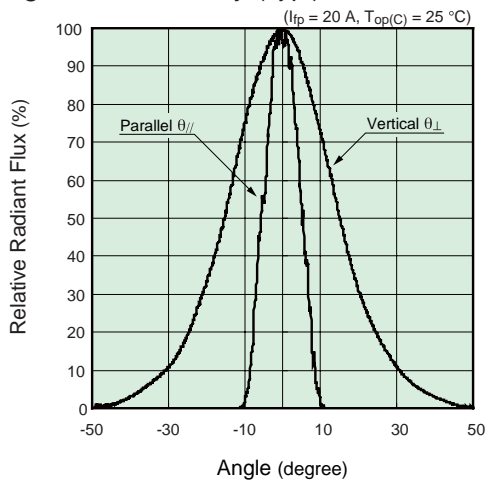
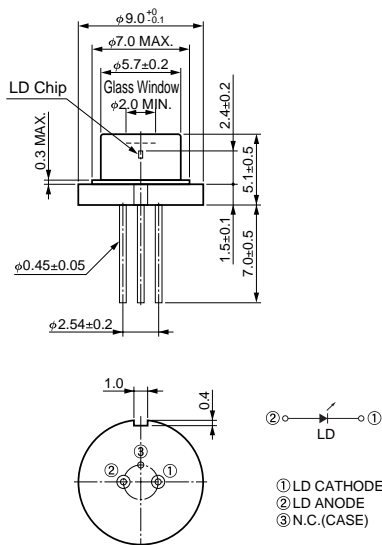

Figure 4: Dimensional Outline (Unit : mm)



HAMAMATSU PHOTONICS K.K. www.hamamatsu.com

HAMAMATSU PHOTONICS K.K., Laser Group, Sales Dept.

1-8-3, Shinmiyakoda, Kita-ku, Hamamatsu City, 431-2103, Japan, Telephone: (81)53-484-1301, Fax: (81)53-484-1302, E-mail: laser-g@lshr.hpk.co.jp

U.S.A.: Hamamatsu Corporation, 360 Foothill Road, P. O. Box 6910, Bridgewater, N.J. 08807-0910, U.S.A., Telephone: (1)908-231-0960, Fax: (1)908-231-1218 E-mail: usa@hamamatsu.com

Germany: Hamamatsu Photonics Deutschland GmbH: Arzbergerstr. 10, D-82211 Herrsching am Ammersee, Germany, Telephone: (49)8152-375-0, Fax: (49)8152-265-8 E-mail: info@hamamatsu.de

France: Hamamatsu Photonics France S.A.R.L.: 19, Rue du Saule Trapu, Parc du Moulin de Massy, 91882 Massy Cedex, France, Telephone: (33)1 69 53 71 00, Fax: (33)1 69 53 71 10 E-mail: infos@hamamatsu.fr

United Kingdom: Hamamatsu Photonics UK Limited: 2 Howard Court, 10 Tewin Road Welwyn Garden City Hertfordshire AL7 1BW, United Kingdom, Telephone: 44-(0)1707-294888, Fax: 44(0)1707-325777 E-mail: info@hamamatsu.co.uk

North Europe: Hamamatsu Photonics Norden AB: Torshamnsgatan 35 16440 Kista, Sweden, Telephone: (46)8-509-031-00, Fax: (46)8-509-031-01 E-mail: info@hamamatsu.se

Italy: Hamamatsu Photonics Italia: S.R.L.: Strada della Moia, 1/E, 20020 Arese, (Milano), Italy, Telephone: (39)02-935 81 733, Fax: (39)02-935 81 741 E-mail: info@hamamatsu.it

China: Hamamatsu Photonics (China) Co., Ltd.: 1201 Tower B, Jiaming Center, 27 Dongsanhuan Road North, Chaoyang District, Beijing 100020, China, Telephone: (86)10-6586-6006, Fax: (86)10-6586-2866 E-mail: hpc@hamamatsu.com.cn

Cat. No. LPLD2016E02
JUN. 2013