

# LM96063

*LM96063 Remote Diode Digital Temperature Sensor with Integrated Fan Control*



Literature Number: SNIS149A

# LM96063

## Remote Diode Digital Temperature Sensor with Integrated Fan Control

### General Description

The LM96063 is remote diode temperature sensors with integrated fan control that includes remote diode sensing. The LM96063 accurately measures: (1) its own temperature and (2) the temperature of a diode-connected transistor, such as a 2N3904, or a thermal diode commonly found on Computer Processors, Graphics Processor Units (GPU) and other ASIC's.

The LM96063 also features an integrated, pulse-width-modulated (PWM), open-drain fan control output. Fan speed is a combination of the remote temperature reading, the lookup table and register settings. The 12-step Lookup Table (LUT) enables the user to program a non-linear fan speed vs. temperature transfer function often used to quiet acoustic fan noise. In addition a fully programmable ramping function has been added to allow smooth transitions between LUT set-points.

The LM96063 is targeted mainly for a transistor MMBT3904 used as thermal diodes or thermal diodes found in many FP-GAs, ASICs, and processors on SOI processes. The LM96163 is identical to the LM96063 except the TruTherm BJT Beta compensation is enabled at power up that is targeted for thermal diodes found on popular processors using bulk non SOI processes.

### Features

- Accurately senses remote diode-connected MMBT3904 transistors or thermal diodes on-board processors, FPGAs or ASICs
- Accurately senses its own local die temperature
- Offset register can adjust for a variety of thermal diodes
- Resolves remote temperatures up to 255.875°C
- 10-bit plus sign and 11-bit unsigned data formats, with 1/8°C resolution
- Digital filter of remote data lowers noise and improves resolution to 1/32°C

- Integrated PWM fan speed control output supports high resolution at 22.5kHz frequency for 4-pin fans
- Acoustic fan noise reduction with User-programmable 12-step Lookup Table
- LUT transition fine resolution smoothing function
- Tachometer input for measuring fan RPM with Smart-Tach modes for measuring RPM of fans when pulse-width-modulating an actual power
- $\overline{\text{ALERT}}$  output for error event notification
- $\overline{\text{TCRIT}}$  output for critical temperature system shutdown
- SMBus 2.0 compatible interface, supports TIMEOUT
- LLP10 packages

### Key Specifications

- Remote Diode Temp Accuracy (TruTherm™ off, includes quantization error)

Ambient Temp	Diode Temp	Max Error
+25 to +85°C	+50 to +105°C	±0.75°C
+25 to +85°C	+40 to +105°C	±1.5°C
-40 to +25°C	+25 to +125°C	±3°C

- Local Temp Accuracy (includes quantization error)

Ambient Temp	Max Error
+25°C to +125°C	±3.0°C

- Supply Voltage 3.0 V to 3.6 V
- Supply Current (0.8Hz Conversion) 456  $\mu\text{A}$  (typ)

### Applications

- Communications Infrastructure FPGA, ASIC or Processor Thermal Management
- Electronic Test and Office Equipment
- Industrial Controls

### Connection Diagram

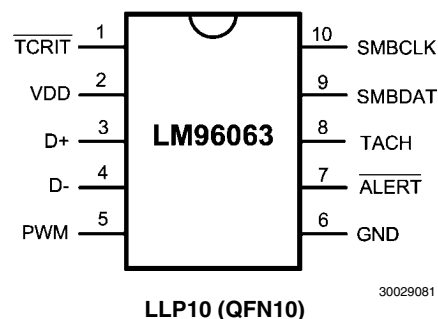

TruTherm™ is a trademark of National Semiconductor Corporation.

## Ordering Information

Part Description	Power-On Defaults		Thermal Diode	Top Mark	Order Number	Transport Media	NS Package Number
	HIGH Threshold	T_CRIT Threshold					
LM96063C 10-pin LLP (QFN)	105°C	110°C	MMBT3904	T63S	LM96063CISD	1000 units in Tape/Reel	SDA10A
LM96063C 10-pin LLP (QFN)	105°C	110°C	MMBT3904	T63S	LM96063CISDX	4500 units in Tape/Reel	SDA10A

## Pin Descriptions

Pin	Name	Input/Output	Function and Connection
1	$\overline{\text{TCRIT}}$	Open-Drain Digital Output	Open-Drain Digital Output. Connect to system shutdown. Pin activates when temperature conversion value exceeds programmed limit. Several power-on-default limit values are available.
2	$V_{\text{DD}}$	Power Supply Input	Connect to a low-noise $+3.3 \pm 0.3 V_{\text{DC}}$ power supply, and bypass to GND with a $0.1 \mu\text{F}$ ceramic capacitor in parallel with a $100 \text{ pF}$ ceramic capacitor. A bulk capacitance of $10 \mu\text{F}$ needs to be in the vicinity of the LM96063's $V_{\text{DD}}$ pin.
3	D+	Analog Input	Connect to the anode (positive side) of the remote diode. A $100\text{pF}$ capacitor can be connected between pins 3 and 4.
4	D-	Analog Input	Connect to the cathode (negative side) of the remote diode. A $100\text{pF}$ capacitor can be connected between pins 3 and 4.
5	PWM	Open-Drain Digital Output	Open-Drain Digital Output. Connect to fan drive circuitry. The power-on default for this pin is low (pin 4 pulled to ground).
6	GND	Ground	This is the analog and digital ground return.
7	$\overline{\text{ALERT}}$	Open-Drain Digital Output	This pin is an open-drain $\overline{\text{ALERT}}$ output.
8	TACH	Digital Input	Tachometer input for measuring fan speed. Note the TACH input is disabled upon power-up and needs to be enabled for use by setting TCHEN bit 2 of Configuration Register 03h.
9	SMBDAT	Digital Input/ Open-Drain Digital Output	This is the bidirectional SMBus data line.
10	SMBCLK	Digital Input	Digital Input. This is the SMBus clock input.

## Simplified Block Diagram

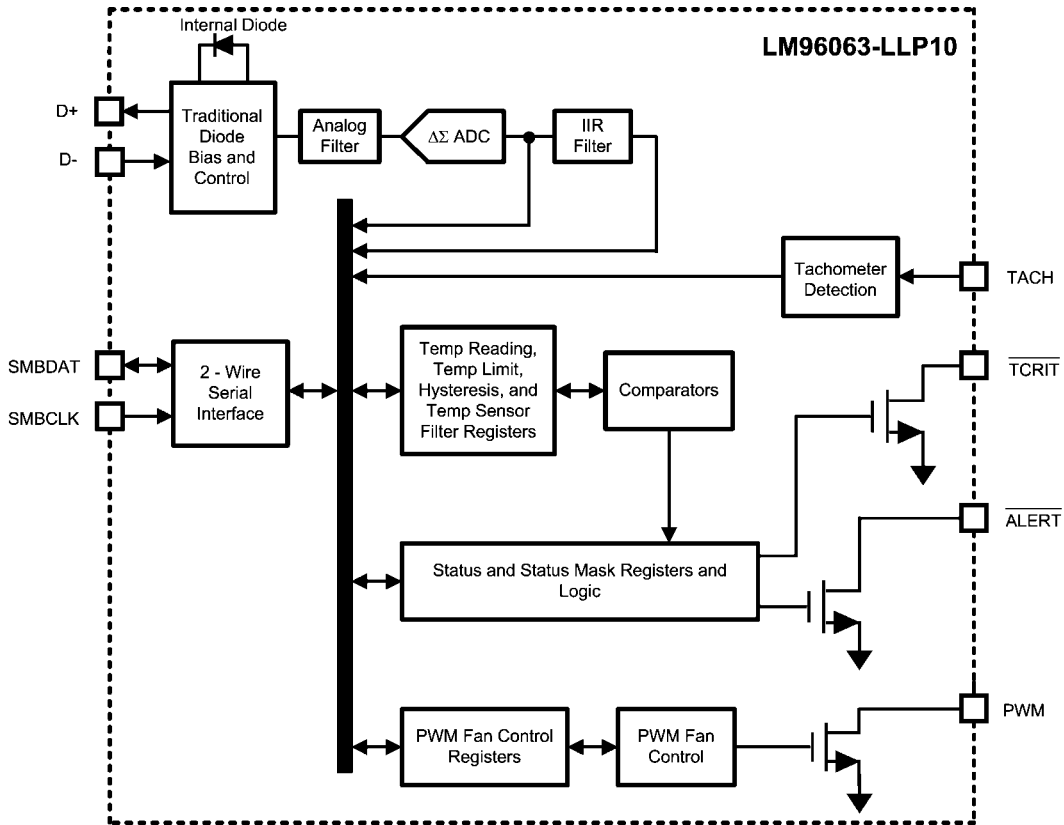

30029082

## Typical Application

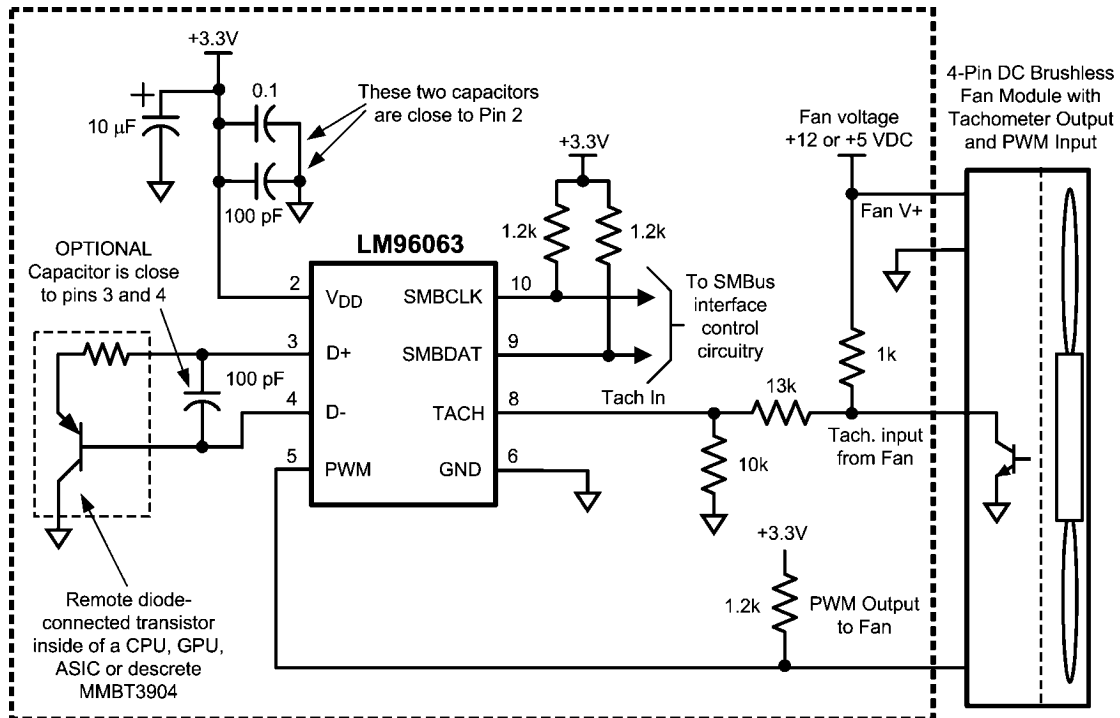

30029003

## Absolute Maximum Ratings *(Note 2, Note 1)*

Supply Voltage, $V_{DD}$	-0.3 V to 6.0 V
Voltage on SMBDAT, SMBCLK, ALERT, TCRIT, TACH PWM Pins	-0.5 V to 6.0 V
Voltage on Other Pins	-0.3 V to ( $V_{DD} + 0.3$ V)
Input Current, D- Pin <i>(Note 3)</i>	$\pm 1$ mA
Input Current at All Other Pins <i>(Note 3)</i>	5 mA
Package Input Current <i>(Note 3)</i>	30 mA
SMBDAT, ALERT, PWM pins	
Output Sink Current	10 mA
Package Power Dissipation <i>(Note 5)</i>	

Junction Temperature	125°C
Storage Temperature	-65°C to +150°C

### ESD Susceptibility *(Note 4)*

Human Body Model	2500 V
Machine Model	250 V
Charged Device Model	1000 V

## Operating Ratings *(Note 1, Note 2)*

Specified Temperature Range	$T_{MIN} \leq T_A \leq T_{MAX}$
LM96063CISD	$-40^\circ\text{C} \leq T_A \leq +85^\circ\text{C}$
Remote Diode Temperature Range	$-40^\circ\text{C} \leq T_D \leq +140^\circ\text{C}$
Supply Voltage Range ( $V_{DD}$ )	+3.0 V to +3.6 V

Soldering process must comply with National Semiconductor's Reflow Temperature Profile specifications. Refer to [www.national.com/packaging](http://www.national.com/packaging). *(Note 6)*

## DC Electrical Characteristics

### TEMPERATURE-TO-DIGITAL CONVERTER CHARACTERISTICS

The following specifications apply for  $V_{DD} = 3.0$  VDC to 3.6 VDC, and all analog source impedance  $R_S = 50\Omega$  unless otherwise specified in the conditions. **Boldface limits apply for  $T_A = T_J = T_{MIN}$  to  $T_{MAX}$** ; all other limits  $T_A = +25^\circ\text{C}$ ; unless otherwise noted.  $T_D$  is the junction temperature of the remote thermal diode.  $T_J$  is the junction temperature of the LM96063.

Parameter	Conditions	Typical <i>(Note 7)</i>	Limits <i>(Note 8)</i>	Units <i>(Limits)</i>
Temperature Error Using an MMBT3904 Remote Thermal Diode	$T_A = +25^\circ\text{C}$ to $+85^\circ\text{C}$ $T_D = +50^\circ\text{C}$ to $+105^\circ\text{C}$ $T_D =$ Remote Diode Junction Temperature		<b><math>\pm 0.75</math></b>	$^\circ\text{C}$ (max)
	$T_A = +25^\circ\text{C}$ to $+85^\circ\text{C}$ $T_D = +40^\circ\text{C}$ to $+125^\circ\text{C}$		<b><math>\pm 1.5</math></b>	$^\circ\text{C}$ (max)
	$T_A = -40^\circ\text{C}$ to $+25^\circ\text{C}$ $T_D = +25^\circ\text{C}$ to $+125^\circ\text{C}$		<b><math>\pm 3.0</math></b>	$^\circ\text{C}$ (max)
Temperature Error Using the Local Diode <i>(Note 9)</i>	$T_A = +25^\circ\text{C}$ to $+125^\circ\text{C}$	$\pm 1$	<b><math>\pm 3</math></b>	$^\circ\text{C}$ (max)
	$T_A = -40^\circ\text{C}$ to $+25^\circ\text{C}$		<b><math>\pm 6</math></b>	$^\circ\text{C}$ (max)
Remote Diode Resolution		11		Bits
		0.125		$^\circ\text{C}$
Local Diode Resolution		8		Bits
		1		$^\circ\text{C}$
Conversion Time, All Temperature Channels	Fastest Setting	38.3	<b>41.1</b>	ms (max)
D- Source Voltage		0.4		V
Diode Source Current	$(V_{D+} - V_{D-}) = +0.65$ V; High Current	172	<b>225</b>	$\mu\text{A}$ (max)
	Low Current	10.75	<b>100</b>	$\mu\text{A}$ (min)
Diode Source Current Ratio		16		

## Operating Electrical Characteristics

Symbol	Parameter	Conditions	Typ <i>(Note 7)</i>	Limits <i>(Note 8)</i>	Units
$V_{POR}$	Power-On-Reset Threshold Voltage			<b>2.8</b>	V (max)
				<b>1.6</b>	V (min)
$I_S$	Supply Current <i>(Note 10)</i>	SMBus Inactive, 13 Hz Conversion Rate	1.1	<b>1.6</b>	mA (max)
		SMBus Inactive, 0.8 Hz Conversion Rate	456	<b>825</b>	$\mu\text{A}$ (max)
		STANDBY Mode	416	<b>700</b>	$\mu\text{A}$ (max)

## AC Electrical Characteristics

The following specifications apply for  $V_{DD} = 3.0$  VDC to 3.6 VDC, and all analog source impedance  $R_S = 50\Omega$  unless otherwise specified in the conditions. **Boldface limits apply for  $T_A = T_{MIN}$  to  $T_{MAX}$** ; all other limits  $T_A = +25^\circ\text{C}$ .

Symbol	Parameter	Conditions	Typical (Note 7)	Limits (Note 8)	Units (Limit)
<b>TACHOMETER ACCURACY</b>					
	Fan Count Accuracy			<b><math>\pm 7</math></b>	% (max)
	Fan Full-Scale Count			<b>65535</b>	(max)
	Fan Counter Clock Frequency		90		kHz
	Fan Count Update Frequency		1.0		Hz
<b>FAN PWM OUTPUT</b>					
	Frequency Accuracy			<b><math>\pm 7</math></b>	% (max)

## Digital Electrical Characteristics

Symbol	Parameter	Conditions	Typical (Note 7)	Limits (Note 8)	Units (Limit)
$V_{IH}$	Logical High Input Voltage			<b>2.1</b>	V (min)
$V_{IL}$	Logical Low Input Voltage			<b>0.8</b>	V (max)
$I_{IH}$	Logical High Input Current	$V_{IN} = V_{DD}$	0.005	<b>+10</b>	$\mu\text{A}$ (max)
$I_{IL}$	Logical Low Input Current	$V_{IN} = \text{GND}$	-0.005	<b>-10</b>	$\mu\text{A}$ (max)
$C_{IN}$	Digital Input Capacitance		5		pF
$V_{OL}$	ALERT, $\overline{\text{TCRIT}}$ and PWM Output Saturation Voltage	$I_{OUT} = 6 \text{ mA}$		<b>0.4</b>	V (max)
$C_{OUT}$	Digital Output Capacitance		5		pF

## SMBus Logical Electrical Characteristics

The following specifications apply for  $V_{DD} = 3.0$  VDC to 3.6 VDC, and all analog source impedance  $R_S = 50\Omega$  unless otherwise specified in the conditions. **Boldface limits apply for  $T_A = T_{MIN}$  to  $T_{MAX}$** ; all other limits  $T_A = +25^\circ\text{C}$ .

Symbol	Parameter	Conditions	Typical (Note 7)	Limits (Note 8)	Units (Limit)
<b>SMBDAT OPEN-DRAIN OUTPUT</b>					
$V_{OL}$	Logic Low Level Output Voltage	$I_{OL} = 4 \text{ mA}$		<b>0.4</b>	V (max)
$I_{OH}$	High Level Output Current	$V_{OUT} = V_{DD}$	0.03	<b>10</b>	$\mu\text{A}$ (max)
$C_{OUT}$	Digital Output Capacitance		5		pF
<b>SMBDAT, SMBCLK INPUTS</b>					
$V_{IH}$	Logical High Input Voltage			<b>2.1</b>	V (min)
$V_{IL}$	Logical Low Input Voltage			<b>0.8</b>	V (max)
$V_{HYST}$	Logic Input Hysteresis Voltage		320		mV
$C_{IN}$	Digital Input Capacitance		5		pF

## SMBus Digital Switching Characteristics

Unless otherwise noted, these specifications apply for  $V_{DD} = +3.0$  VDC to  $+3.6$  VDC,  $C_L$  (load capacitance) on output lines = 80 pF. **Boldface limits apply for  $T_A = T_J$ ;  $T_{MIN} \leq T_A \leq T_{MAX}$** ; all other limits  $T_A = T_J = +25^\circ\text{C}$ , unless otherwise noted. The switching characteristics of the LM96063 fully meet or exceed the published specifications of the SMBus version 2.0. The following parameters are the timing relationships between SMBCLK and SMBDAT signals related to the LM96063. They adhere to but are not necessarily the same as the SMBus bus specifications.

Symbol	Parameter	Conditions	Limits ( <i>Note 8</i> )	Units (Limit)
$f_{SMB}$	SMBus Clock Frequency		<b>10</b> <b>100</b>	kHz (min) kHz (max)
$t_{LOW}$	SMBus Clock Low Time	From $V_{IN(0) \max}$ to $V_{IN(0) \max}$	<b>4.7</b>	$\mu\text{s}$ (min)
$t_{HIGH}$	SMBus Clock High Time	From $V_{IN(1) \min}$ to $V_{IN(1) \min}$	<b>4.0</b> <b>50</b>	$\mu\text{s}$ (min) $\mu\text{s}$ (max)
$t_R$	SMBus Rise Time	( <i>Note 11</i> )	<b>1</b>	$\mu\text{s}$ (max)
$t_F$	SMBus Fall Time	( <i>Note 12</i> )	<b>0.3</b>	$\mu\text{s}$ (max)
$t_{OF}$	Output Fall Time	$C_L = 400$ pF, $I_O = 3$ mA	<b>250</b>	ns (max)
$t_{TIMEOUT}$	SMBDAT and SMBCLK Time Low for Reset of Serial Interface See ( <i>Note 13</i> )		<b>25</b> <b>35</b>	ms (min) ms (max)
$t_{SU:DAT}$	Data In Setup Time to SMBCLK High		<b>250</b>	ns (min)
$t_{HD:DAT}$	Data Out Hold Time after SMBCLK Low		<b>300</b> <b>1075</b>	ns (min) ns (max)
$t_{HD:STA}$	Hold Time after (Repeated) Start Condition. After this period the first clock is generated.		<b>4.0</b>	$\mu\text{s}$ (min)
$t_{SU:STO}$	Stop Condition SMBCLK High to SMBDAT Low (Stop Condition Setup)		<b>100</b>	ns (min)
$t_{SU:STA}$	SMBus Repeated Start-Condition Setup Time, SMBCLK High to SMBDAT Low		<b>4.7</b>	$\mu\text{s}$ (min)
$t_{BUF}$	SMBus Free Time between Stop and Start Conditions		<b>4.7</b>	$\mu\text{s}$ (min)

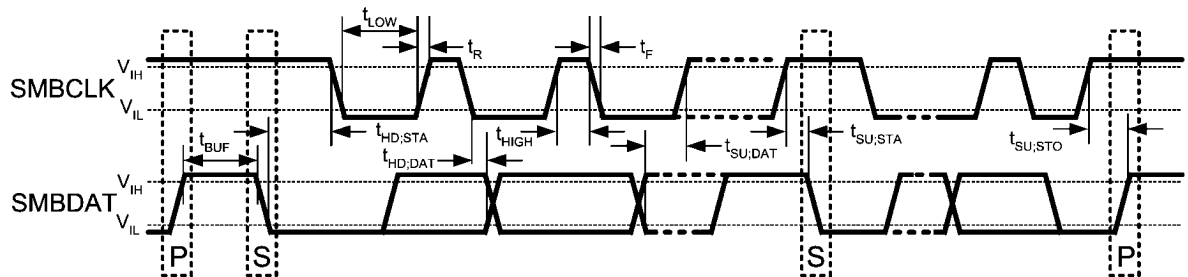

SMBus Timing Diagram for SMBCLK and SMBDAT Signals

30029004

**Note 1:** Absolute Maximum Ratings indicate limits beyond which damage to the device may occur. Operating Ratings indicate conditions for which the device is functional, but do not guarantee performance limits. For guaranteed specifications and test conditions, see the Electrical Characteristics. The guaranteed specifications apply only for the test conditions listed. Some performance characteristics may degrade when the device is not operated under the listed test conditions.

**Note 2:** All voltages are measured with respect to GND, unless otherwise noted.

**Note 3:** When the input voltage ( $V_{IN}$ ) at any pin exceeds the power supplies ( $V_{IN} < \text{GND}$  or  $V_{IN} > V_+$ ), the current at that pin should be limited to 5 mA. Parasitic components and/or ESD protection circuitry are shown below for the LM96063's pins. Care should be taken not to forward bias the parasitic diode, D2, present on pins D+ and D-. Doing so by more than 50 mV may corrupt temperature measurements.

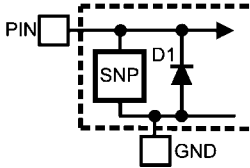
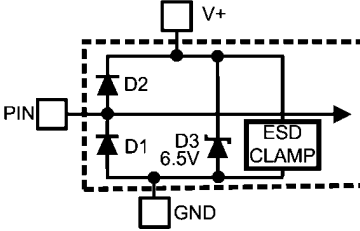
Pin #	Label	Circuit	Pin ESD Protection Structure Circuits
1	$\overline{\text{TCRIT}}$	A	 <p><b>CIRCUIT A</b></p>
2	$V_{\text{DD}}$	B	
3	D+	B	
4	D-	B	
5	PWM	A	
6	GND	B	
7	$\overline{\text{ALERT}}$	A	
8	TACH	A	
9	SMBDAT	A	
10	SMBCLK	A	 <p><b>CIRCUIT B</b></p>

**Note 4:** Human body model, 100 pF discharged through a 1.5 k $\Omega$  resistor. Machine model, 200 pF discharged directly into each pin. Charged Device Model (CDM) simulates a pin slowly acquiring charge (such as from a device sliding down the feeder in an automated assembler) then rapidly being discharged.

**Note 5:** Thermal resistance junction to ambient when attached to a 2 layer 4"x3" printed circuit board with copper thickness of 2oz. as described in JEDEC specification EIA/JESD51-3 is 137°C/W. Thermal resistance junction to ambient when attached to a 4 layer 4"x3" printed circuit board with copper thickness 2oz./1oz./1oz./2oz. and 4 thermal vias as described in JEDEC specification EIA/JESD51-7 is 40.3°C/W.

**Note 6:** Reflow temperature profiles are different for packages containing lead (Pb) than for those that do not.

**Note 7:** "Typicals" are at  $T_A = 25^\circ\text{C}$  and represent most likely parametric norm. They are to be used as general reference values not for critical design calculations.

**Note 8:** Limits are guaranteed to National's AOQL (Average Outgoing Quality Level).

**Note 9:** Local temperature accuracy does not include the effects of self-heating. The rise in temperature due to self-heating is the product of the internal power dissipation of the LM96063 and the thermal resistance. See ([Note 5](#)) for the thermal resistance to be used in the self-heating calculation.

**Note 10:** The supply current will not increase substantially with an SMBus transaction.

**Note 11:** The output rise time is measured from ( $V_{\text{IL,max}} - 0.15\text{ V}$ ) to ( $V_{\text{IH,min}} + 0.15\text{ V}$ ).

**Note 12:** The output fall time is measured from ( $V_{\text{IH,min}} + 0.15\text{ V}$ ) to ( $V_{\text{IL,max}} - 0.15\text{ V}$ ).

**Note 13:** Holding the SMBDAT and/or SMBCLK lines Low for a time interval greater than  $t_{\text{TIMEOUT}}$  will reset the LM96063's SMBus state machine, therefore setting SMBDAT and SMBCLK pins to a high impedance state.

## Typical Performance Characteristics

Remote Temperature Reading Sensitivity to Thermal Diode Filter Capacitance

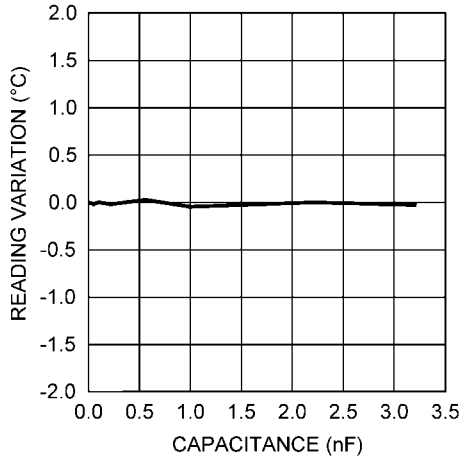

30029053

Thermal Diode Capacitor or PCB Leakage Current Effect on Remote Diode Temperature Reading

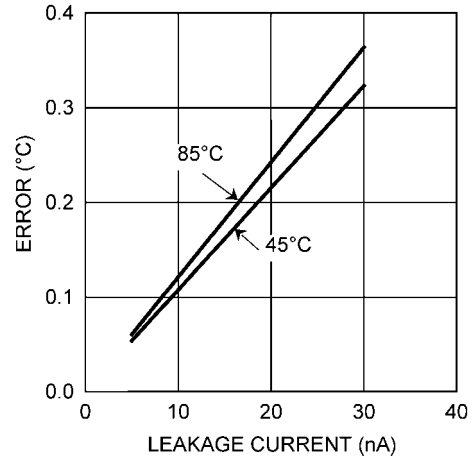

30029022

Conversion Rate Effect on Average Power Supply Current

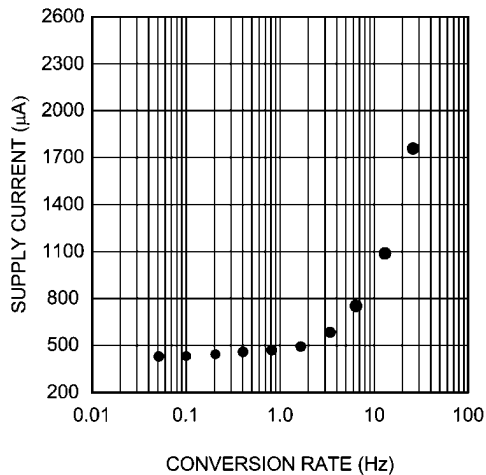

30029006

## 1.0 Functional Description

The LM96063 Remote Diode Temperature Sensor with Integrated Fan Control incorporates a  $\Delta V_{BE}$ -based temperature sensor utilizing a Local or Remote diode and a 10-bit plus sign  $\Delta\Sigma$  ADC (Delta-Sigma Analog-to-Digital Converter). The pulse-width modulated (PWM) open-drain output, with a pull-up resistor, is driven by a 12-point temperature to duty cycle look-up table (LUT) and can directly drive a PWM input of a 4-pin fan in order to modulate its speed enabling optimum system acoustic performance. The LM96063 LUT fan control algorithm also includes a smoothing function that allows the PWM duty cycle to gradually change over a programmed time interval when switching from one level to the next in the LUT. When running at a frequency of 22.5kHz the PWM output resolution is 0.39%. The LM96063 includes a TACH input that can measure the speed of a fan using the pulses from a 3 or 4 pin fan's tachometer output. The LM96063 includes a smart-tach measurement mode to accommodate the corrupted tachometer pulses when using switching transistor power drive to modulate the fan speed. The LM96063 has an

$\overline{\text{ALERT}}$  open-drain output that will be pulled low when the measured temperature exceeds certain programmed limits when enabled. Details are contained in the sections below.

The LM96063 can measure a diode-connected transistor such as the MMBT3904 or the thermal diode found in an FPGA, ASIC, Processor or any other device built on an SOI process accurately. The LM96163 is identical to the LM96063 except the TruTherm BJT Beta compensation is included. Thermal diode TruTherm BJT compensation circuitry is required when sensing thermal diodes mainly found in 22/45/65/90 nm conventional bulk CMOS non SOI processes. The LM96063's two-wire interface is compatible with the SMBus Specification 2.0. For more information the reader is directed to [www.smbus.org](http://www.smbus.org).

In the LM96063 digital comparators are used to compare the measured Local Temperature (LT) to the Local High Setpoint user-programmable temperature limit register. The measured Remote Temperature (RT) is digitally compared to the Remote High Setpoint (RHS), the Remote Low Setpoint (RLS), and the Remote T\_CRIT Setpoint (RCS) user-programmable temperature limits. An  $\overline{\text{ALERT}}$  output will occur when the

measured temperature is: (1) higher than either the High Setpoint or the T\_CRIT Setpoint, or (2) lower than the Low Setpoint. The ALERT Mask register allows the user to prevent the generation of these ALERT outputs. A TCRIT output will occur when the measured temperature is higher than the T\_CRIT Setpoint.

The TCRIT function and the look-up table temperature hysteresis can be set separately. The hysteresis value associated with the TCRIT output is set in the Remote T\_CRIT Hysteresis Register. The value associated with the look-up table function is set in the Lookup Table Hysteresis Register.

The LM96063 may be placed in a low power Standby mode by setting the Standby bit found in the Configuration Register. In the Standby mode continuous conversions are stopped. In Standby mode the user may choose to allow the PWM output signal to continue, or not, by programming the PWM Disable in Standby bit in the Configuration Register.

The Local Temperature reading and setpoint data registers are 8-bits wide. The format of the 11-bit remote temperature data is a 16-bit left justified word. Two 8-bit registers, high and low bytes, are provided for each setpoint as well as the temperature reading. A digital filter may be invoked for remote temperature readings that increases the resolution from 11-bits to 13-bits. The temperature readings are also available in an unsigned format allowing resolution above 127°C. Two Remote Temperature Offset (RTO) Registers: High Byte and Low Byte (RTOHB and RTOLB) may be used to correct the temperature readings by adding or subtracting a fixed value based on a different non-ideality factor and series resistance of the thermal diode if different from the thermal diode found in the Intel processors on 45 nm process. See section 3.4 [DIODE NON-IDEALITY](#).

## 1.2 ALERT and TCRIT OUTPUTS

In this section we will address the ALERT and TCRIT active-low open-drain output functions. When the ALERT Mask bit in the Configuration register is written as zero the ALERT interrupts are enabled.

The LM96063's ALERT pin is versatile and can produce three different methods of use to best serve the system designer: (1) as a temperature comparator (2) as a temperature-based interrupt flag, and (3) as part of an SMBus ALERT System. The three methods of use are further described below. The ALERT and interrupt methods are different only in how the user interacts with the LM96063.

The remote temperature (RT) reading is associated with a T\_CRIT Setpoint Register, and both local and remote temperature (LT and RT) readings are associated with a HIGH setpoint register (LHS and RHS). The RT is also associated with a LOW setpoint register (RLS). At the end of every temperature reading a digital comparison determines whether that reading is above its HIGH or T\_CRIT setpoint or below its LOW setpoint. If so, the corresponding bit in the ALERT Status Register is set. If the ALERT mask bit is low, any bit set in the ALERT Status Register, with the exception of Busy or RDFA, will cause the ALERT output to be pulled low. Any temperature conversion that is out of the limits defined in the temperature setpoint registers will trigger an ALERT. Additionally, the ALERT Mask Bit must be cleared to trigger an ALERT in all modes.

The format of the Remote High limit and T\_CRIT limit comparison is programmable. The USF bit found in the Enhanced Configuration register controls whether comparisons use a signed or unsigned format. The temperature format used for Remote High and T\_CRIT limit comparisons is +255.875 °C to -256 °C.

The three different ALERT modes and TCRIT function will be discussed in the following sections.

### 1.2.1 ALERT Output as a Temperature Comparator

When the LM96063 is used in a system in which does not require temperature-based interrupts, the ALERT output could be used as a temperature comparator. In this mode, once the condition that triggered the ALERT to go low is no longer present, the ALERT is negated ([Figure 1](#)). For example, if the ALERT output was activated by the comparison of  $LT > LHS$ , when this condition is no longer true, the ALERT will return HIGH. This mode allows operation without software intervention, once all registers are configured during set-up. In order for the ALERT to be used as a temperature comparator, the Comparator Mode bit in the Remote Diode Temperature Filter and Comparator Mode Register must be asserted. This is not the power-on default state.

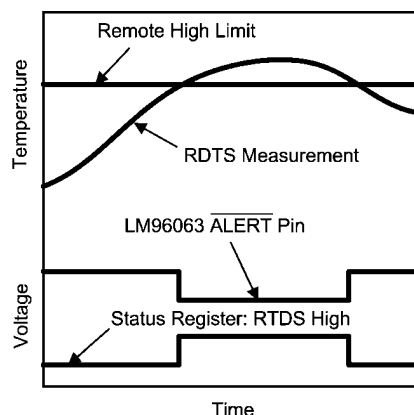

30029007

**FIGURE 1. ALERT Output as Temperature Comparator Response Diagram**

### 1.2.2 ALERT Output as an Interrupt

The LM96063's ALERT output can be implemented as a simple interrupt signal when it is used to trigger an interrupt service routine. In such systems it is desirable for the interrupt flag to repeatedly trigger during or before the interrupt service routine has been completed. Under this method of operation, during the read of the ALERT Status Register the LM96063 will set the ALERT Mask bit in the Configuration Register if any bit in the ALERT Status Register is set, with the exception of Busy and RDFA. This prevents further ALERT triggering until the master has reset the ALERT Mask bit, at the end of the interrupt service routine. The ALERT Status Register bits are cleared only upon a read command from the master (see [Figure 2](#)) and will be re-asserted at the end of the next conversion if the triggering condition(s) persist(s). In order for the ALERT to be used as a dedicated interrupt signal, the Comparator Mode bit in the Remote Diode Temperature Filter and Comparator Mode Register must be set low. This is the power-on default state. The following sequence describes the response of a system that uses the ALERT output pin as an interrupt flag:

1. Master senses ALERT low.
2. Master reads the LM96063 ALERT Status Register to determine what caused the ALERT.
3. LM96063 clears ALERT Status Register, resets the ALERT HIGH and sets the ALERT Mask bit in the Configuration Register.

- Master attends to conditions that caused the  $\overline{\text{ALERT}}$  to be triggered. The fan is started, setpoint limits are adjusted, etc.
- Master resets the ALERT Mask bit in the Configuration Register.

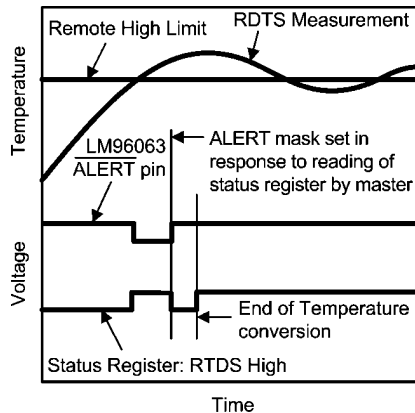

30029008

**FIGURE 2.  $\overline{\text{ALERT}}$  Output as an Interrupt Temperature Response Diagram**

### 1.2.3 $\overline{\text{ALERT}}$ Output as an SMBus ALERT

An SMBus alert line is created when the  $\overline{\text{ALERT}}$  output is connected to: (1) one or more  $\overline{\text{ALERT}}$  outputs of other SMBus compatible devices, and (2) to a master. Under this implementation, the LM96063's  $\overline{\text{ALERT}}$  should be operated using the ARA (Alert Response Address) protocol. The SMBus 2.0 ARA protocol, defined in the SMBus specification 2.0, is a procedure designed to assist the master in determining which part generated an interrupt and to service that interrupt.

The SMBus alert line is connected to the open-drain ports of all devices on the bus, thereby AND'ing them together. The ARA method allows the SMBus master, with one command, to identify which part is pulling the SMBus alert line LOW. It also prevents the part from pulling the line LOW again for the same triggering condition. When an ARA command is received by all devices on the bus, the devices pulling the SMBus alert line LOW: (1) send their address to the master and (2) release the SMBus alert line after acknowledgement of their address.

The SMBus Specifications 1.1 and 2.0 state that in response to an ARA (Alert Response Address) "after acknowledging the slave address the device must disengage its  $\overline{\text{ALERT}}$  pull-down". Furthermore, "if the host still sees  $\overline{\text{ALERT}}$  low when the message transfer is complete, it knows to read the ARA again." This SMBus "disengaging  $\overline{\text{ALERT}}$ " requirement prevents locking up the SMBus alert line. Competitive parts may address the "disengaging of  $\overline{\text{ALERT}}$ " differently than the LM96063 or not at all. SMBus systems that implement the ARA protocol as suggested for the LM96063 will be fully compatible with all competitive parts.

The LM96063 fulfills "disengaging of  $\overline{\text{ALERT}}$ " by setting the ALERT Mask Bit in the Configuration Register after sending out its address in response to an ARA and releasing the  $\overline{\text{ALERT}}$  output pin. Once the ALERT Mask bit is activated, the  $\overline{\text{ALERT}}$  output pin will be disabled until enabled by software. In order to enable the  $\overline{\text{ALERT}}$  the master must read the ALERT Status Register, during the interrupt service routine and then reset the ALERT Mask bit in the Configuration Register to 0 at the end of the interrupt service routine.

The following sequence describes the ARA response protocol.

- Master senses SMBus alert line low
- Master sends a START followed by the Alert Response Address (ARA) with a Read Command.
- Alerting Device(s) send ACK.
- Alerting Device(s) send their address. While transmitting their address, alerting devices sense whether their address has been transmitted correctly. (The LM96063 will reset its  $\overline{\text{ALERT}}$  output and set the ALERT Mask bit once its complete address has been transmitted successfully.)
- Master/slave NoACK
- Master sends STOP
- Master attends to conditions that caused the ALERT to be triggered. The ALERT Status Register is read and fan started, setpoints adjusted, etc.
- Master resets the ALERT Mask bit in the Configuration Register.

The ARA, 000 1100, is a general call address. No device should ever be assigned to this address.

The ALERT Configuration bit in the Remote Diode Temperature Filter and Comparator Mode Register must be set low in order for the LM96063 to respond to the ARA command.

The  $\overline{\text{ALERT}}$  output can be disabled by setting the ALERT Mask bit in the Configuration Register. The power-on default is to have the ALERT Mask bit and the ALERT Configuration bit low.

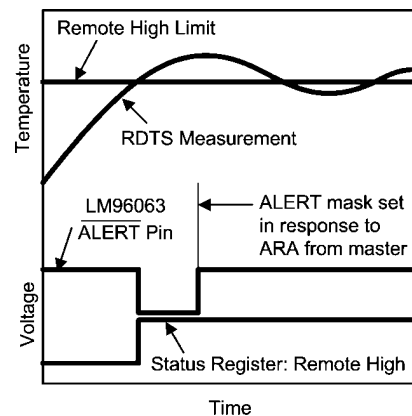

30029009

**FIGURE 3.  $\overline{\text{ALERT}}$  Output as an SMBus ALERT Temperature Response Diagram**

### 1.2.4 $\overline{\text{TCRIT}}$ Function

The  $\overline{\text{TCRIT}}$  output will be activated whenever the RCRIT bit in the ALERT Status register is set. This occurs whenever the remote temperature exceeds the value set by the Remote T\_CRIT Setpoint register. There is a hysteresis associated with the T\_CRIT Setpoint that is set by the value in the Remote T\_CRIT Hysteresis register. The RCRIT bit will be reset when the remote temperature equals or is less than the value defined by Remote T\_CRIT Setpoint minus T\_CRIT Hysteresis. The resolution of the comparison is 1 °C. For example if T\_CRIT = 110 °C and THYST = 5 °C the TCRIT output will activate when the temperature reading is 111 °C and deactivate when the temperature reading is 105 °C.

When the LM96063 powers up the T\_CRIT limit is locked to the default value. It may be changed after the T\_CRIT Limit

Override bit (TCRITOV) bit, found in the Configuration Register, is set.

The format of the Remote T\_CRIT setpoint register is controlled by the USF bit found in the Enhanced configuration register. The temperature reading format used for the T\_CRIT comparisons is +255 °C to -256°C.

### 1.3 SMBus INTERFACE

Since the LM96063 operates as a slave on the SMBus the SMBCLK line is an input and the SMBDAT line is bidirectional. The LM96063 never drives the SMBCLK line and it does not support clock stretching. According to SMBus specifications, the LM96063 has a 7-bit slave address. All bits, A6 through A0, are internally programmed and cannot be changed by software or hardware.

The complete slave address is:

A6	A5	A4	A3	A2	A1	A0
1	0	0	1	1	0	0

### 1.4 POWER-ON RESET (POR) DEFAULT STATES

For information on the POR default states see Section 2.2 LM96063 Register Map in Functional Order.

### 1.5 TEMPERATURE DATA FORMAT

Temperature data can only be read from the Local and Remote Temperature value registers. The data format for all temperature values is left justified 16-bit word available in two 8-bit registers. Unused bits will always report "0". All temperature data is clamped and will not roll over when a temperature exceeds full-scale value.

Remote temperature and remote high setpoint temperature data can be represented by an 11-bit, two's complement word or unsigned binary word with an LSb (Least Significant Bit) equal to 0.125°C.

#### 11-bit, 2's complement (10-bit plus sign)

Temperature	Digital Data	
	Binary	Hex
+125°C	0111 1101 0000 0000	7D00h
+25°C	0001 1001 0000 0000	1900h
+1°C	0000 0001 0000 0000	0100h
+0.125°C	0000 0000 0010 0000	0020h
0°C	0000 0000 0000 0000	0000h
-0.125°C	1111 1111 1110 0000	FFE0h
-1°C	1111 1111 0000 0000	FF00h
-25°C	1110 0111 0000 0000	E700h
-55°C	1100 1001 0000 0000	C900h

#### 11-bit, unsigned binary

Temperature	Digital Data	
	Binary	Hex
+255.875°C	1111 1111 1110 0000	FFE0h
+255°C	1111 1111 0000 0000	FF00h
+201°C	1100 1001 0000 0000	C900h
+125°C	0111 1101 0000 0000	7D00h
+25°C	0001 1001 0000 0000	1900h
+1°C	0000 0001 0000 0000	0100h
+0.125°C	0000 0000 0010 0000	0020h
0°C	0000 0000 0000 0000	0000h

When the digital filter is enabled on the remote channel, temperature data is represented by a 13-bit unsigned binary or 12-bit plus sign (two's complement) word with an LSb equal to 0.03125°C.

#### 13-bit, 2's complement (12-bit plus sign)

Temperature	Digital Data	
	Binary	Hex
+125°C	0111 1101 0000 0000	7D00h
+25°C	0001 1001 0000 0000	1900h
+1°C	0000 0001 0000 0000	0100h
+0.03125°C	0000 0000 0000 1000	0008h
0°C	0000 0000 0000 0000	0000h
-0.03125°C	1111 1111 1111 1000	FFF8h
-1°C	1111 1111 0000 0000	FF00h
-25°C	1110 0111 0000 0000	E700h
-55°C	1100 1001 0000 0000	C900h

#### 13-bit, unsigned binary

Temperature	Digital Data	
	Binary	Hex
+255.875°C	1111 1111 1110 0000	FFE0h
+255°C	1111 1111 0000 0000	FF00h
+201°C	1100 1001 0000 0000	C900h
+125°C	0111 1101 0000 0000	7D00h
+25°C	0001 1001 0000 0000	1900h
+1°C	0000 0001 0000 0000	0100h
+0.03125°C	0000 0000 0000 1000	0008h
0°C	0000 0000 0000 0000	0000h

Local Temperature and Remote T\_CRIT setpoint data is represented by an 8-bit, two's complement, word with an LSb equal to 1°C.

#### 8-bit, 2's complement (7-bit plus sign)

Temperature	Digital Data	
	Binary	Hex
+125°C	0111 1101	7Dh
+25°C	0001 1001	19h
+1°C	0000 0001	01h
0°C	0000 0000	00h
-1°C	1111 1111	FFh
-25°C	1110 0111	E7h
-55°C	1100 1001	C9h

Remote T\_CRIT setpoint data can also be represented by an 8-bit, unsigned, word with an LSb equal to 1°C.

#### 8-bit, unsigned binary

Temperature	Digital Data	
	Binary	Hex
+255°C	1111 1111	FFh
+150°C	1001 0110	96h
+125°C	0111 1101	7Dh
+25°C	0001 1001	19h
+1°C	0000 0001	01h
0°C	0000 0000	00h

### 1.6 OPEN-DRAIN OUTPUTS

The SMBDAT,  $\overline{\text{ALERT}}$ ,  $\overline{\text{TCRIT}}$  and PWM outputs are open-drain outputs and do not have internal pull-ups. A “High” level will not be observed on these pins until pull-up current is provided by an internal source, typically through a pull-up resistor. Choice of resistor value depends on several factors but, in general, the value should be as high as possible consistent with reliable operation. This will lower the power dissipation of the LM96063 and avoid temperature errors caused by self-heating of the device. The maximum value of the pull-up resistor to provide the 2.1 V high level is 88.7 k $\Omega$ .

### 1.7 DIODE FAULT DETECTION

The LM96063 is equipped with operational circuitry designed to detect remote diode fault conditions:

- D+ shorted to  $V_{DD}$
- D+ open or floating
- D+ shorted to GND.

In the event that the D+ pin is grounded the Remote Temperature reading is forced to  $-128.000\text{ }^{\circ}\text{C}$  if signed format is read and  $0\text{ }^{\circ}\text{C}$  if unsigned format is read. When the D+ pin is detected as shorted to  $V_{DD}$  or floating, the Remote Temperature reading is forced to  $+127.000\text{ }^{\circ}\text{C}$  if signed format is read and  $+255.000\text{ }^{\circ}\text{C}$  if unsigned format is read. In addition, the ALERT Status register bit RDFA is set. Setting of the RDFA bit will not cause ALERT or TCRIT to activate. Under fault

conditions remote diode setpoint comparisons will use these forced temperature values therefore other bits in the ALERT Status Register may be set thus activating the ALERT or TCRIT outputs unless these bits are masked. The function of the ALERT and TCRIT is fully described in Section [1.2  \$\overline{\text{ALERT}}\$  and  \$\overline{\text{TCRIT}}\$  OUTPUTS](#).

### 1.8 COMMUNICATING WITH THE LM96063

Each data register in the LM96063 falls into one of four types of user accessibility:

1. Read Only
2. Write Only
3. Read/Write same address
4. Read/Write different address

A Write to the LM96063 is comprised of an address byte and a command byte. A write to any register requires one data byte.

Reading the LM96063 Registers can take place after the requisite register setup sequence takes place. See Section 2.1.1 LM96063 Required Initial Fan Control Register Sequence.

The data byte has the Most Significant Bit (MSB) first. At the end of a read, the LM96063 can accept either Acknowledge or No-Acknowledge from the Master. Note that the No-Acknowledge is typically used as a signal for the slave indicating that the Master has read its last byte.

## 1.9 DIGITAL FILTER

In order to suppress erroneous remote temperature readings due to noise as well as increase the resolution of the temperature, the LM96063 incorporates a digital filter for remote temperature readings. The filter is accessed in the Remote Diode Temperature Filter and Comparator Mode Register. The filter can be set according to the following table.

RDTF[1:0]		Filter Setting
0	0	No Filter
0	1	Filter (equivalent to Level 2 filter of the LM86/LM89)
1	0	Reserved
1	1	Enhanced Filter (Filter with transient noise clipping)

Figure 4 describes the filter output in response to a step input and an impulse input.

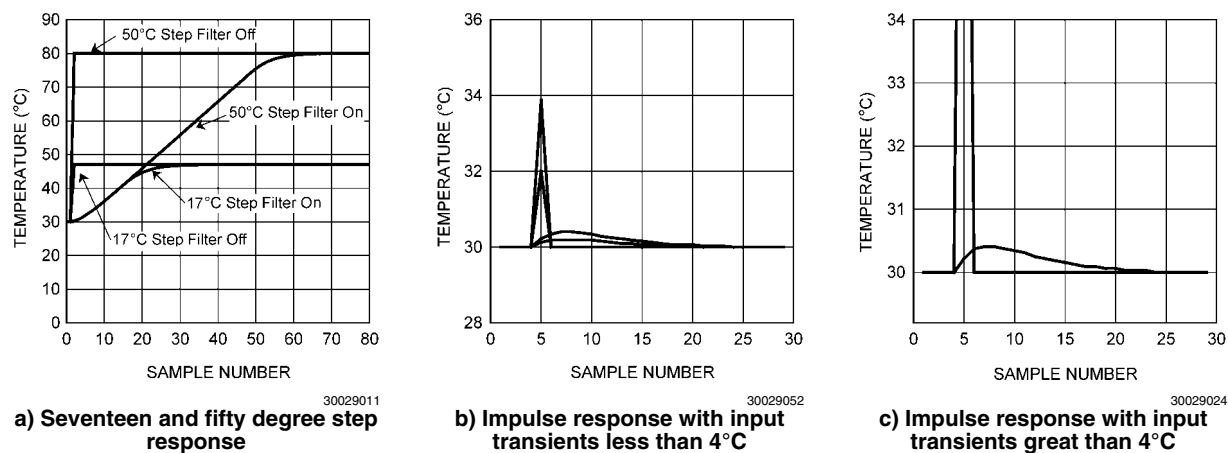
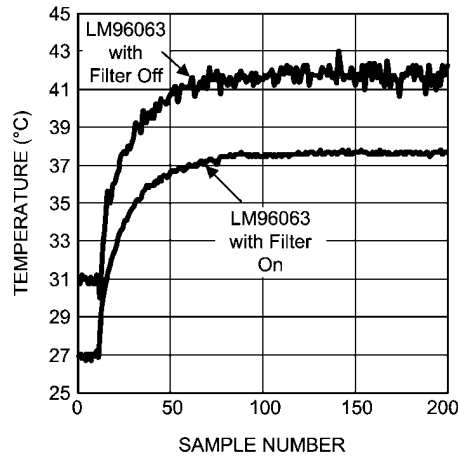

FIGURE 4. Filter Impulse and Step Response Curves



30029012

**FIGURE 5. The filter curves were purposely offset for clarity.**

Figure 5 shows the filter in use in a typical Intel processor on a 65/90 nm process system. Note that the two curves have been purposely offset for clarity. Inserting the filter does not induce an offset as shown.

### 1.10 FAULT QUEUE

The LM96063 incorporates a Fault Queue to suppress erroneous ALERT triggering. The Fault Queue prevents false triggering by requiring three consecutive out-of-limit HIGH or LOW temperature readings. See Figure 6. The Fault Queue defaults to OFF upon power-up and may be activated by setting the RDTS Fault Queue bit in the Configuration Register to a 1.

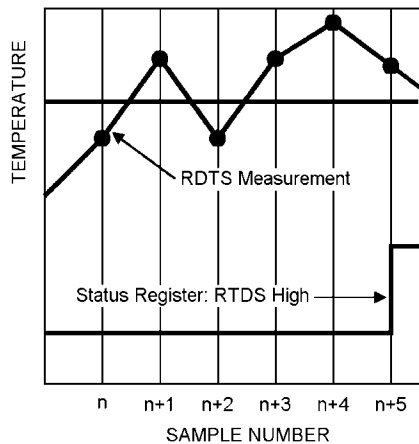

30029013

**FIGURE 6. Fault Queue Temperature Response Diagram**

### 1.11 ONE-SHOT REGISTER

The One-Shot Register is used to initiate a single conversion and comparison cycle when the device is in standby mode, after which the data returns to standby. This is not a data register. A write operation causes the one-shot conversion. The data written to this address is irrelevant and is not stored. A zero will always be read from this register.

### 1.12 SERIAL INTERFACE RESET

In the event that the SMBus Master is reset while the LM96063 is transmitting on the SMBDAT line, the LM96063 must be returned to a known state in the communication protocol. This may be done in one of two ways:

1. When SMBDAT is Low, the LM96063 SMBus state machine resets to the SMBus idle state if either SMBDAT or SMBCLK are held Low for more than 35 ms ( $t_{\text{TIMEOUT}}$ ). Devices are to timeout when either the SMBCLK or SMBDAT lines are held Low for 25 ms – 35 ms. Therefore, to insure a timeout of devices on the bus, either the SMBCLK or the SMBDAT line must be held Low for at least 35 ms.
2. With both SMBDAT and SMBCLK High, the master can initiate an SMBus start condition with a High to Low transition on the SMBDAT line. The LM96063 will respond properly to an SMBus start condition at any point during the communication. After the start the LM96063 will expect an SMBus Address address byte.

## 2.0 LM96063 Registers

The following pages include: Section 2.1, a Register Map in Hexadecimal Order, which shows a summary of all registers and their bit assignments, Section 2.2, a Register Map in Functional Order, and Section 2.3, a detailed explanation of each register. Do not address the unused or manufacturer's test registers.

### 2.1 LM96063 REGISTER MAP IN HEXADECIMAL ORDER

The following is a Register Map grouped in hexadecimal address order. Some address locations have been left blank to maintain compatibility with LM86, LM63 and LM64. Addresses in parenthesis are mirrors of "Same As" address for backwards compatibility with some older software. Reading or writing either address will access the same 8-bit register.

Register 0x[HEX]	R/ W	POR Val	Register Name	DATA BITS							
				D7	D6	D5	D4	D3	D2	D1	D0
00	R	–	Local Temperature (Signed MSB)	LT7 SIGN	LT6 64	LT5 32	LT4 16	LT3 8	LT2 4	LT1 2	LT0 1
01	R	–	Rmt Temp MSB	RT12 SIGN	RT11 64	RT10 32	RT9 16	RT8 8	RT7 4	RT6 2	RT5 1
02	R	–	ALERT Status	BUSY	LHIGH	0	RHIGH	RLOW	RDFA	RCRIT	TACH
03	R/ W	00	Configuration	ALTMASK	STBY	PWMDIS	0	0	TCHEN	TCRIT0 V	FLTQUE
04	R/ W	08	Conversion Rate	0	0	0	0	CONV3	CONV2	CONV1	CONV0
05	R/ W	46	Local High Setpoint	LHS7 SIGN	LHS6 64	LHS5 32	LHS4 16	LHS3 8	LHS2 4	LHS1 2	LHS0 1
06			[Reserved]	Not Used							
07	R/ W	69	Rmt High Setpoint MSB	RHS10 SIGN /128	RHS9 64	RHS8 32	RHS7 16	RHS6 8	RHS5 4	RHS4 2	RHS3 1
08	R/ W	00	Rmt Low Setpoint MSB	RLS10 SIGN	RLS9 64	RLS8 32	RLS7 16	RLS6 8	RLS5 4	RLS4 2	RLS3 1
(09)	R/ W	00	Same as 03	ALTMASK	STBY	PWMDIS	0	0	TCHEN	TCRIT0 V	FLTQUE
(0A)	R/ W	08	Same as 04	0	0	0	0	CONV3	CONV2	CONV1	CONV0
(0B)	R/ W	46	Same as 05	LHS7 SIGN	LHS6 64	LHS5 32	LHS4 16	LHS3 8	LHS2 4	LHS1 2	LHS0 1
0C	R	00	[Reserved]	Not Used							
(0D)	R/ W	69	Same as 07	RHS10 SIGN /128	RHS9 64	RHS8 32	RHS7 16	RHS6 8	RHS5 4	RHS4 2	RHS3 1
(0E)	R/ W	00	Same as 08	RLS10 SIGN	RLS9 64	RLS8 32	RLS7 16	RLS6 8	RLS5 4	RLS4 2	RLS3 1
0F	W	–	One Shot	Write Only. Write command triggers one temperature conversion cycle.							
10	R	–	Rmt Temp LSB (Dig Filter On or Reg 45h STFBE bit set)	RT4 ½	RT3 ¼	RT2 ⅛	RT1 1/16	RT0 1/32	0	0	0
			Rmt Temp LSB (Dig Filter Off)				0	0			
11	R/ W	00	Rmt Temp Offset MSB	RTO10 SIGN	RTO9 64	RTO8 32	RTO7 16	RTO7 8	RTO5 4	RTO4 2	RTO3 1
12	R/ W	00	Rmt Temp Offset LSB	RTO2 ½	RTO1 ¼	RTO0 ⅛	0	0	0	0	0
13	R/ W	00	Rmt High Setpoint LSB	RHS2 ½	RHS1 ¼	RHS0 ⅛	0	0	0	0	0

Register 0x[HEX]	R/W	POR Val	Register Name	DATA BITS							
				D7	D6	D5	D4	D3	D2	D1	D0
14	R/W	00	Rmt Low Setpoint LSB	RLS2 ½	RLS1 ¼	RLS0 ⅛	0	0	0	0	0
15	R	00	[Reserved]	Not Used							
16	R/W	A4	ALERT Mask	1	LHAM	1	RHAM	RLAM	1	RTAM	TCHAM
17-18	R	00	[Reserved]	Not Used							
19	R/W	6E	Rmt T_CRIT Setpoint	RCS7 SIGN /128	RCS6 64	RCS5 32	RCS4 16	RCS3 8	RCS2 4	RCS1 2	RCS0 1
1A-20	R	00	[Reserved]	Not Used							
21	R/W	0A	Rmt T_CRIT Hysteresis	RTH7 0	RTH6 64	RTH5 32	RTH4 16	RTH3 8	RTH2 4	RTH1 2	RTH0 1
22-2F	R	00	[Reserved]	Not Used							
30	R	00	[Reserved]	0	0	0	0	0	0	0	0
31	R	-	Rmt Temp U-S MSB	RTU12 128	RTU11 64	RTU10 32	RTU9 16	RTU8 8	RTU7 4	RTU6 2	RTU5 1
32	R	-	Rmt Temp U-S LSB Dig Filter On	RTU4 ½	RTU3 ¼	RTU2 ⅛	RTU1 1/16	RTU0 1/32	0	0	0
			Rmt Temp U-S LSB Dig Filter Off				0	0			
33	R	-	POR Status	NR	0	0	0	0	0	0	0
34-44	R	00	[Reserved]	Not Used							
45	R/W	00	Enhanced Config	0	STFBE	LRES	PHR	USF	RRS1	RRS0	PSRR
46	R	-	Tach Count LSB	TAC5	TAC4	TAC3	TAC2	TAC1	TAC0	TEDGE1	TEDGE0
47	R	-	Tach Count MSB	TAC13	TAC12	TAC11	TAC10	TAC9	TAC8	TAC7	TAC6
48	R/W	FF	Tach Limit LSB	TACL5	TACL4	TACL3	TACL2	TACL1	TACL0	Not Used 0	Not Used -
49	R/W	FF	Tach Limit MSB	TACL13	TACL12	TACL11	TACL10	TACL9	TACL8	TACL7	TACL6
4A	R/W	20	PWM and RPM Config	0	0	PWPGM	PWOP	PWCKSL	0	TACH1	TACH0
4B	R/W	3F	Fan Spin-Up Config	0	0	SPINUP	SPNDTY 1	SPNDTY 0	SPNTIM 2	SPNTIM1	SPNTIM0
4C	R/W	00	PWM Value	HPWVAL 7	HPWVAL 6	PWVAL5	PWVAL4	PWVAL3	PWVAL2	PWVAL1	PWVAL0
4D	R/W	17	PWM Frequency	0	0	0	PWMF4	PWMF3	PWMF2	PWMF1	PWMF0
4E	R/W	00	Lookup Table Temp Offset	0	0	TO5 32	TO4 16	TO3 8	TO2 4	TO1 2	TO0 1
4F	R/W	04	Lookup Table Hysteresis	0	0	0	LOOKH4 16	LOOKH3 8	LOOKH2 4	LOOKH1 2	LOOKH0 1
50-67	R/W	3F, 7F	Lookup Table	Lookup Table of up to 12 PWM (3F) and Temp Pairs in 8-bit Registers (7F)							
68-BE	R	00	[Reserved]	Not Used							
BF	R/W	00	Rmt Diode Temp Filter	0	0	0	0	0	RDTF1	RDTF0	ALT/CMP
C0-FD	R	00	[Reserved]	Not Used							
FE	R	01	Manufacturer's ID	0	0	0	0	0	0	0	1
FF	R	49	Step/Die Rev. ID	0	1	0	0	1	0	0	1

## 2.2 LM96063 REGISTER MAP IN FUNCTIONAL ORDER

The following is a Register Map grouped in Functional Order. Some address locations have been left blank to maintain compatibility with LM86. Addresses in parenthesis are mirrors of named address. Reading or writing either address will access the same 8-bit register. The Fan Control and Configuration Registers are listed first, as there is a required order to setup these registers first and then setup the others. The detailed explanations of each register will follow the order shown below. POR = Power-On-Reset.

Register [HEX]	Register Name	Read/Write	POR Default [HEX]
<b>FAN CONTROL REGISTERS</b>			
45	Enhanced Configuration	R/W	00
4A	PWM and RPM Configuration	R/W	20
4B	Fan Spin-Up Configuration	R/W	3F
4D	PWM Frequency	R/W	17
4C	PWM Value	Read Only (R/W if Override Bit is Set)	00
4E	Lookup Table Temperature Offset	R/W	00
4F	Lookup Table Hysteresis Temperature	R/W	04
50–67	Lookup Table	R/W	See Table
<b>CONFIGURATION REGISTER</b>			
03 (09)	Configuration	R/W	00
<b>TACHOMETER COUNT AND LIMIT REGISTERS</b>			
46	Tach Count LSB	Read Only	N/A
47	Tach Count MSB	Read Only	N/A
48	Tach Limit LSB	R/W	FF
49	Tach Limit MSB	R/W	FF
<b>LOCAL TEMPERATURE AND LOCAL SETPOINT REGISTERS</b>			
00	Local Temperature	Read Only	N/A
05 (0B)	Local High Setpoint	R/W	46 (70°)
<b>REMOTE DIODE TEMPERATURE AND SETPOINT REGISTERS</b>			
01	Remote Temperature Signed MSB	Read Only	N/A
10	Remote Temperature Signed LSB	Read Only	N/A
31	Remote Temperature Unsigned MSB	Read Only	N/A
32	Remote Temperature Unsigned LSB	Read Only	N/A
11	Remote Temperature Offset MSB	R/W	00
12	Remote Temperature Offset LSB	R/W	00
07 (0D)	Remote High Setpoint MSB	R/W	69 (105°C)
13	Remote High Setpoint LSB	R/W	00
08 (0E)	Remote Low Setpoint MSB	R/W	00 (0°C)
14	Remote Low Setpoint LSB	R/W	00
19	Remote T_CRIT Setpoint	R/W	6E (110°C)
21	Remote T_CRIT Hyst	R/W	0A (10°C)
BF	Remote Diode Temperature Filter and Comparator Mode	R/W	00
<b>CONVERSION AND ONE-SHOT REGISTERS</b>			
04 (0A)	Conversion Rate	R/W	08
0F	One-Shot	Write Only	N/A
<b>STATUS AND MASK REGISTERS</b>			
02	ALERT Status	Read Only	N/A
16	ALERT Mask	R/W	A4
33	Power On Reset Status	Read Only	N/A
<b>ID AND TEST REGISTERS</b>			
FE	Manufacturer ID	Read Only	01
FF	Stepping/Die Rev. ID	Read Only	49

Register [HEX]	Register Name	Read/Write	POR Default [HEX]
<b>[RESERVED] REGISTERS—NOT USED</b>			
06	Not Used	N/A	N/A
0C	Not Used	N/A	N/A
15	Not Used	N/A	N/A
17-18	Not Used	N/A	N/A
1A-20	Not Used	N/A	N/A
22-29	Not Used	N/A	N/A
34-44	Not Used	N/A	N/A
68-BE	Not Used	N/A	N/A
C0-FD	Not Used	N/A	N/A

### 2.3 LM96063 REQUIRED INITIAL FAN CONTROL REGISTER SEQUENCE

**Important!** The BIOS or firmware must follow the sequence below to configure the following Fan Registers for the LM96063 before using any of the Fan or Tachometer or PWM registers:

Step	[Register] <sub>HEX</sub> and Setup Instructions
1	After power up check to make sure that the Not Ready bit is cleared in the POR Status register [33] bit 7.
2	[4A] Write bits 0 and 1; 3 and 4. This includes tach settings if used, PWM internal clock select (1.4 kHz or 360 kHz) and PWM Output Polarity.
3	[4B] Write bits 0 through 5 to program the spin-up settings.
4	[4D] Write bits 0 through 4 to set the frequency settings. This works with the PWM internal clock select. If 22.5 kHz is selected then enhanced fan control functions such as Lookup Table transition smoothing with extended PWM duty cycle resolution is available and should be setup [45].
5	Choose, then write, <b>only one</b> of the following: A. [4F-67] the Lookup Table and [4E] the Lookup Table Offset, [45] Lookup Table Temperature Resolution can also be modified <b>or</b> B. [4C] the PWM value bits 0 through 5 or bits 0 through 7 if extended duty cycle resolution is selected.
6	If Step 4A, Lookup Table, was chosen and written then write [4A] bit 5 PWPGM = 0. PWPGM should be set to 1 to enable writing to the fan control registers listed in this table.

All other registers can be written at any time after the above sequence.

## 2.4 LM96063 DETAILED REGISTER DESCRIPTIONS IN FUNCTIONAL ORDER

The following is a Register Map grouped in functional and sequence order. New register addresses have been added to maintain compatibility with the LM63 and LM64 register sets. Addresses in parenthesis are mirrors of named address for backwards compatibility with some older software. Reading or writing either address will access the same 8-bit register.

### Fan Control Registers

Address Hex	Read/Write	Bits	POR Value	Name	Description
<b>45<sub>HEX</sub> ENHANCED CONFIGURATION</b>					
45	R	7	0	[Reserved]	This bit is unused and always read as 0.
	R/W	6	0	STFBE	Signed Temperature Filter Bits Enable 0: external signed temperature LSbs [4:3] will always read "0" (backwards compatible with the LM63) 1: when the digital filter is enabled the external signed temperature LSbs [4:3] (1/16 and 1/32 resolution) are enabled
	R/W	5	0	LRES	Lookup Table Resolution Extension 0: LUT temperature resolution 7-bits (LSb = 1°C, backwards compatible with the LM63) 1: enable 8-bit LUT temperature resolution (LSb extended to 0.5°C)
	R/W	4	0	PHR	22.5kHz PWM High Resolution Control (only effective when PWM frequency set to 22.5kHz) 0: PWM resolution 6.25% (backwards compatible with the LM63) 1: enable high resolution (0.39%)
	R/W	3	0	USF	Unsigned High and T_CRIT Setpoint Format 0: enable signed format for High and T_CRIT setpoints (11-bit is -128.000°C to 127.875°C or 8-bit is -128°C to 127°C) 1: enable unsigned format for High and T_CRIT setpoints (11-bit is 0°C to 255.875°C or 8-bit is 0°C to 255°C)
	R/W	2:1	00	RRS1:RRS0	PWM Smoothing Ramp Rate Setting (these bits can modified only when PWM Programming is enabled, 0x4A[5]=1) 00: 0.023 s per step (5.45 seconds for 0 to 100% duty cycle transition with 0.39% resolution) 01: 0.046 s per step (10.9 seconds for 0 to 100% duty cycle transition with 0.39% resolution) 10: 0.91 s per step (21.6 seconds for 0 to 100% duty cycle transition with 0.39% resolution) 11: 0.182 s per step (43.7 seconds for 0 to 100% duty cycle transition with 0.39% resolution) Note: PWM smoothing is disabled for PWM spinup and for duty cycle setting override caused by a TCRIT event, thus it is only enabled during LUT transitions. PWM smoothing is only effective when PWM frequency is set to 22.5kHz.
	R/W	0	0	PSRR	PWM Smoothing Ramp Rate Control (this bit can modified only when the PWM Programming is enabled, 0x4A[5]=1) 0: PWM smoothing disabled (LM63 backwards compatible) 1: enable ramp rate control (as controlled by 0x45[2:1]) Note: PWM smoothing is disabled for PWM spinup and for duty cycle setting override caused by a TCRIT event, thus it is only enabled during LUT transitions. PWM smoothing is only effective when PWM frequency is set to 22.5kHz

Address Hex	Read/Write	Bits	POR Value	Name	Description
<b>4A<sub>HEX</sub> FAN PWM AND TACHOMETER CONFIGURATION REGISTER</b>					
4A	R	7:6	00	[Reserved]	These bits are unused and always read as 0.
	R/W	5	1	PWPGM	<p>PWM Programming enable</p> <p>0: the PWM Value (register 0x4C), the PWM Smoothing (0x45[2:0]) and the Lookup Table (Registers 0x50–0x67) are read-only. The PWM value (0 to 100%) is determined by the current remote diode temperature and the Lookup Table, and can be read from the PWM value register.</p> <p>1: the PWM value (register 0x4C), the PWM Smoothing (0x45[2:0]) and the Lookup Table (Registers 0x50–0x67) are read/write enabled. Writing the PWM Value register will set the PWM output. This is also the state during which the Lookup Table can be written.</p>
		4	0	PWOP	<p>PWM Output Polarity</p> <p>0: the PWM output pin will be 0V for fan OFF and open for fan ON.</p> <p>1: the PWM output pin will be open for fan OFF and 0V for fan ON.</p>
		3	0	PWCLSL	<p>PWM Master Clock Select</p> <p>0: the master PWM clock is 360 kHz</p> <p>1: the master PWM clock is 1.4 kHz.</p>
		2	0	[Reserved]	Always write 0 to this bit.
		1:0	00	TACH1:TACH0	<p>Tachometer Mode</p> <p>00: Traditional tach input monitor, false readings when under minimum detectable RPM. (Smart-TACH mode disabled)</p> <p>01: Traditional tach input monitor, FFFFh reading when under minimum detectable RPM. Smart-TACH mode enabled, PWM duty cycle not affected. Use with direct PWM drive of fan power. TACH readings can cause an error event if TACH setpoint register is set to less than FFFFh even though fan may be spinning properly.</p> <p>10: Most accurate readings, FFFFh reading when under minimum detectable RPM. Smart-TACH mode enabled, PWM duty cycle modified. Use with direct PWM drive of fan power. This mode extends the TACH monitoring low RPM sensitivity.</p> <p>11: Least effort on programmed PWM of fan, FFFF reading when under minimum detectable RPM. Smart-TACH mode enabled. Use with direct PWM drive of fan power. This mode extends the TACH monitoring low RPM sensitivity the most.</p> <p>Note: If the PWM Master Clock is 360 kHz, mode 00 is used regardless of the setting of these two bits.</p>

Address Hex	Read/Write	Bits	POR Value	Name	Description
<b>4B<sub>HEX</sub> FAN SPIN-UP CONFIGURATION REGISTER</b>					
4B	R	7:6	0	[Reserved]	These bits are unused and always read as 0
	R/W	5	1	SPINUP	Fast Tachometer Spin-up If 0, the fan spin-up uses the duty cycle and spin-up time, bits 0–4. If 1, the LM96063 sets the PWM output to 100% until the spin-up times out (per bits 0–2) or the minimum desired RPM has been reached (per the Tachometer Setpoint setting) using the tachometer input, whichever happens first. This bit overrides the PWM Spin-Up Duty Cycle register (bits 4:3)—PWM output is always 100%. Register x03, bit 2 = 1 for Tachometer mode. If PWM Spin-Up Time (bits 2:0) = 000, the Spin-Up cycle is bypassed, regardless of the state of this bit.
		4:3	11	SPNDTY1:SPNDTY0	PWM Spin-Up Duty Cycle 00: Spin-Up cycle bypassed (no Spin-Up), unless Fast Tachometer Terminated Spin-Up (bit 5) is set. 01: 50% 10: 75%–81% Depends on PWM Frequency. See Applications Notes. 11: 100%
2:0	111	SPNTIM2:SPNTIM0	PWM Spin-Up Time Interval 000: Spin-Up cycle bypassed (No Spin-Up) 001: 0.05 seconds 010: 0.1 s 011: 0.2 s 100: 0.4 s 101: 0.8 s 110: 1.6 s 111: 3.2 s		
<b>4C<sub>HEX</sub> PWM VALUE REGISTER</b>					
4C	Read (Write only if reg 4A bit 5 = 1.)	7:6	00	HPWVAL7:HPWVAL6	PWM High Resolution and Low Resolution Values If PWM Program (register 4A, bit 5) = 0 this register is read only, this register reflects the LM96063's current PWM value from the Lookup Table. If PWM Program (register 4A, bit 5) = 1, this register is read/write and the desired PWM value is written directly to this register, instead of from the Lookup Table, for direct fan speed control. This register will read 0 during the Spin-Up cycle. See Application Notes section at the end of this datasheet for more information regarding the PWM Value and Duty Cycle in %.
		5:0	0x00	PWVAL5:PWVAL0	
<b>4D<sub>HEX</sub> FAN PWM FREQUENCY REGISTER</b>					
4D	R	7:5	000	[Reserved]	These bits are unused and always read as 0
	R/W	4:0	0x17	PWMF4:PWMF0	PWM Output Frequency The PWM Frequency = PWM_Clock / 2n, where PWM Master Clock = 360 kHz or 1.4 kHz (per the PWM Master Clock Select bit in Register 4A), and n = value of the register. Note: n = 0 is mapped to n = 1. See the Application Note at the end of this datasheet.
<b>4E<sub>HEX</sub> LOOKUP TABLE TEMPERATURE OFFSET</b>					
4E	R	7:6	00	[Reserved]	These bits are unused and always read as 0.
	R/W	5:0	0x00	TO5:TO0	The temperature offset applied to the temperature values of the lookup table. This offset allows the lookup table temperature settings to be extended above 127°C. The value, which is always positive, has an unsigned format with 1°C resolution. The maximum offset that can be programmed is +63°C.
<b>4F<sub>HEX</sub> LOOKUP TABLE HYSTERESIS</b>					
4F	R	7:5	000	[Reserved]	These bits are unused and always read as 0
	R/W	4:0	0x04	LOOKH4:LOOKH0	Lookup Table Hysteresis The amount of hysteresis applied to the Lookup Table. (1 LSB = 1°C, max value 31°C, default value 10°C).

Address Hex	Read/Write	Bits	POR Value	Name	Description
<b>50<sub>HEX</sub> to 67<sub>HEX</sub> LOOKUP TABLE (7/8 Bits for Temperature and 6/8 Bits for PWM for each Temperature/PWM Pair)</b>					
50	Read. (Write only if reg 4A bit 5 = 1)	7	0	E1T7	Lookup Table Temperature Entry 1
		6:0	0x7F	E1T6:E1T0	Bit 7 is unused and always set to 0 in the low resolution temperature LUT mode. In the high resolution temperature LUT mode bit 7 in conjunction with bits 6:0 of this register are used to determine the limit temperature that the remote diode temperature is compared to. In high resolution the range is 0°C to 127.5°C. In low resolution mode the range is 0°C to 127°C. If the remote diode temperature exceeds this value, the PWM output will be the value in Register 0x51. Only 9-bits of the temperature reading are used in high resolution and 8-bits in low resolution. Only positive temperature values can be programmed in this register and in all cases the sign bit is assumed to be zero. Temperatures greater than 127 °C or 127.5 °C can be programmed through the use of the Lookup Table Temperature Offset Register (4Eh).
51	Read. (Write only if reg 4A bit 5 = 1)	7:6	00	E1D7:E1D6	Lookup Table PWM Duty Cycle Extended Entry 1 These bits are unused and always set to 0 in the low resolution duty cycle LUT mode. In the high resolution duty cycle LUT mode these bits in association with bits 5:0 of this register are used for the PWM value associated with the temperature limit in register 0x50. These bits can only be activated when PWM frequency of 22.5kHz is chosen.
		5:0	0x3F	E1D5:E1D0	Lookup Table PWM Duty Cycle Entry 1 The PWM value corresponding to the temperature limit in register 0x50 for the low resolution PWM mode.
52	Read. (Write only if reg 4A bit 5 = 1)	7	0	E2T7	Lookup Table Temperature Entry 2
		6:0	0x7F	E2T6:E2T0	Bit 7 is unused and always set to 0 in the low resolution temperature LUT mode. In the high resolution temperature LUT mode bit 7 in conjunction with bits 6:0 of this register are used to determine the limit temperature that the remote diode temperature is compared to. In high resolution the range is 0°C to 127.5°C. In low resolution mode the range is 0°C to 127°C. If the remote diode temperature exceeds this value, the PWM output will be the value in Register 0x53. Only 9-bits of the temperature reading are used in high resolution and 8-bits in low resolution. Only positive temperature values can be programmed in this register and in all cases the sign bit is assumed to be zero. Temperatures greater than 127 °C or 127.5 °C can be programmed through the use of the Lookup Table Temperature Offset Register (4Eh).
53	Read. (Write only if reg 4A bit 5 = 1)	7:6	00	E2D7:E2D6	Lookup Table PWM Duty Cycle Extended Entry 2 These bits are unused and always set to 0 in the low resolution duty cycle LUT mode. In the high resolution duty cycle LUT mode these bits in association with bits 5:0 of this register are used for the PWM value associated with the temperature limit in register 0x52. These bits can only be activated when PWM frequency of 22.5kHz is chosen.
		5:0	0x3F	E2D5:E2D0	Lookup Table PWM Duty Cycle Entry 2 The PWM value corresponding to the temperature limit in register 0x52 for the low resolution PWM mode.

Address Hex	Read/Write	Bits	POR Value	Name	Description
54	Read. (Write only if reg 4A bit 5 = 1)	7	0	E3T7	Lookup Table Temperature Entry 3 Bit 7 is unused and always set to 0 in the low resolution temperature LUT mode.
		6:0	0x7F	E3T6:E3T0	In the high resolution temperature LUT mode bit 7 in conjunction with bits 6:0 of this register are used to determine the limit temperature that the remote diode temperature is compared to. In high resolution the range is 0°C to 127.5°C. In low resolution mode the range is 0°C to 127°C. If the remote diode temperature exceeds this value, the PWM output will be the value in Register 0x55. Only 9-bits of the temperature reading are used in high resolution and 8-bits in low resolution. Only positive temperature values can be programmed in this register and in all cases the sign bit is assumed to be zero. Temperatures greater than 127 °C or 127.5 °C can be programmed through the use of the Lookup Table Temperature Offset Register (4Eh).
55	Read. (Write only if reg 4A bit 5 = 1)	7:6	00	E3D7:E3D6	Lookup Table PWM Duty Cycle Extended Entry 3 These bits are unused and always set to 0 in the low resolution duty cycle LUT mode. In the high resolution duty cycle LUT mode these bits in association with bits 5:0 of this register are used for the PWM value associated with the temperature limit in register 0x54. These bits can only be activated when PWM frequency of 22.5kHz is chosen.
		5:0	0x3F	E3D5:E3D0	Lookup Table PWM Duty Cycle Entry 3 The PWM value corresponding to the temperature limit in register 0x54 for the low resolution PWM mode.
56	Read. (Write only if reg 4A bit 5 = 1)	7	0	E4T7	Lookup Table Temperature Entry 4 Bit 7 is unused and always set to 0 in the low resolution temperature LUT mode.
		6:0	0x7F	E4T6:E4T0	In the high resolution temperature LUT mode bit 7 in conjunction with bits 6:0 of this register are used to determine the limit temperature that the remote diode temperature is compared to. In high resolution the range is 0°C to 127.5°C. In low resolution mode the range is 0°C to 127°C. If the remote diode temperature exceeds this value, the PWM output will be the value in Register 0x57. Only 9-bits of the temperature reading are used in high resolution and 8-bits in low resolution. Only positive temperature values can be programmed in this register and in all cases the sign bit is assumed to be zero. Temperatures greater than 127 °C or 127.5 °C can be programmed through the use of the Lookup Table Temperature Offset Register (4Eh).
57	Read. (Write only if reg 4A bit 5 = 1)	7:6	00	E4D7:E4D6	Lookup Table PWM Duty Cycle Extended Entry 4 These bits are unused and always set to 0 in the low resolution duty cycle LUT mode. In the high resolution duty cycle LUT mode these bits in association with bits 5:0 of this register are used for the PWM value associated with the temperature limit in register 0x56. These bits can only be activated when PWM frequency of 22.5kHz is chosen.
		5:0	0x3F	E4D5:E4D0	Lookup Table PWM Duty Cycle Entry 4 The PWM value corresponding to the temperature limit in register 0x56 for the low resolution PWM mode.

Address Hex	Read/Write	Bits	POR Value	Name	Description
58	Read. (Write only if reg 4A bit 5 = 1)	7	0	E5T7	Lookup Table Temperature Entry 5
		6:0	0x7F	E5T6:E5T0	Bit 7 is unused and always set to 0 in the low resolution temperature LUT mode. In the high resolution temperature LUT mode bit 7 in conjunction with bits 6:0 of this register are used to determine the limit temperature that the remote diode temperature is compared to. In high resolution the range is 0°C to 127.5°C. In low resolution mode the range is 0°C to 127°C. If the remote diode temperature exceeds this value, the PWM output will be the value in Register 0x59. Only 9-bits of the temperature reading are used in high resolution and 8-bits in low resolution. Only positive temperature values can be programmed in this register and in all cases the sign bit is assumed to be zero. Temperatures greater than 127 °C or 127.5 °C can be programmed through the use of the Lookup Table Temperature Offset Register (4Eh).
59	Read. (Write only if reg 4A bit 5 = 1)	7:6	00	E5D7:E5D6	Lookup Table PWM Duty Cycle Extended Entry 5 These bits are unused and always set to 0 in the low resolution duty cycle LUT mode. In the high resolution duty cycle LUT mode these bits in association with bits 5:0 of this register are used for the PWM value associated with the temperature limit in register 0x58. These bits can only be activated when PWM frequency of 22.5kHz is chosen.
		5:0	0x3F	E5D5:E5D0	Lookup Table PWM Duty Cycle Entry 5 The PWM value corresponding to the temperature limit in register 0x58 for the low resolution PWM mode.
5A	Read. (Write only if reg 4A bit 5 = 1)	7	0	E6T7	Lookup Table Temperature Entry 6
		6:0	0x7F	E6T6:E6T0	Bit 7 is unused and always set to 0 in the low resolution temperature LUT mode. In the high resolution temperature LUT mode bit 7 in conjunction with bits 6:0 of this register are used to determine the limit temperature that the remote diode temperature is compared to. In high resolution the range is 0°C to 127.5°C. In low resolution mode the range is 0°C to 127°C. If the remote diode temperature exceeds this value, the PWM output will be the value in Register 0x5B. Only 9-bits of the temperature reading are used in high resolution and 8-bits in low resolution. Only positive temperature values can be programmed in this register and in all cases the sign bit is assumed to be zero. Temperatures greater than 127 °C or 127.5 °C can be programmed through the use of the Lookup Table Temperature Offset Register (4Eh).
5B	Read. (Write only if reg 4A bit 5 = 1)	7:6	00	E6D7:E6D6	Lookup Table PWM Duty Cycle Extended Entry 6 These bits are unused and always set to 0 in the low resolution duty cycle LUT mode. In the high resolution duty cycle LUT mode these bits in association with bits 5:0 of this register are used for the PWM value associated with the temperature limit in register 0x5A. These bits can only be activated when PWM frequency of 22.5kHz is chosen.
		5:0	0x3F	E6D5:E6D0	Lookup Table PWM Duty Cycle Entry 6 The PWM value corresponding to the temperature limit in register 0x5A for the low resolution PWM mode.

Address Hex	Read/Write	Bits	POR Value	Name	Description
5C	Read. (Write only if reg 4A bit 5 = 1)	7	0	E7T7	Lookup Table Temperature Entry 7 Bit 7 is unused and always set to 0 in the low resolution temperature LUT mode.
		6:0	0x7F	E7T6:E7T0	In the high resolution temperature LUT mode bit 7 in conjunction with bits 6:0 of this register are used to determine the limit temperature that the remote diode temperature is compared to. In high resolution the range is 0°C to 127.5°C. In low resolution mode the range is 0°C to 127°C. If the remote diode temperature exceeds this value, the PWM output will be the value in Register 0x5D. Only 9-bits of the temperature reading are used in high resolution and 8-bits in low resolution. Only positive temperature values can be programmed in this register and in all cases the sign bit is assumed to be zero. Temperatures greater than 127 °C or 127.5 °C can be programmed through the use of the Lookup Table Temperature Offset Register (4Eh).
5D	Read. (Write only if reg 4A bit 5 = 1)	7:6	00	E7D7:E7D6	Lookup Table PWM Duty Cycle Extended Entry 7 These bits are unused and always set to 0 in the low resolution duty cycle LUT mode. In the high resolution duty cycle LUT mode these bits in association with bits 5:0 of this register are used for the PWM value associated with the temperature limit in register 0x5C. These bits can only be activated when PWM frequency of 22.5kHz is chosen.
		5:0	0x3F	E7D5:E7D0	Lookup Table PWM Duty Cycle Entry 7 The PWM value corresponding to the temperature limit in register 0x5C for the low resolution PWM mode.
5E	Read. (Write only if reg 4A bit 5 = 1)	7	0	E8T7	Lookup Table Temperature Entry 8 Bit 7 is unused and always set to 0 in the low resolution temperature LUT mode.
		6:0	0x7F	E8T6:E8T0	In the high resolution temperature LUT mode bit 7 in conjunction with bits 6:0 of this register are used to determine the limit temperature that the remote diode temperature is compared to. In high resolution the range is 0°C to 127.5°C. In low resolution mode the range is 0°C to 127°C. If the remote diode temperature exceeds this value, the PWM output will be the value in Register 0x5F. Only 9-bits of the temperature reading are used in high resolution and 8-bits in low resolution. Only positive temperature values can be programmed in this register and in all cases the sign bit is assumed to be zero. Temperatures greater than 127 °C or 127.5 °C can be programmed through the use of the Lookup Table Temperature Offset Register (4Eh).
5F	Read. (Write only if reg 4A bit 5 = 1)	7:6	00	E8D7:E8D6	Lookup Table PWM Duty Cycle Extended Entry 8 These bits are unused and always set to 0 in the low resolution duty cycle LUT mode. In the high resolution duty cycle LUT mode these bits in association with bits 5:0 of this register are used for the PWM value associated with the temperature limit in register 0x5E. These bits can only be activated when PWM frequency of 22.5kHz is chosen.
		5:0	0x3F	E8D5:E8D0	Lookup Table PWM Duty Cycle Entry 8 The PWM value corresponding to the temperature limit in register 0x5E for the low resolution PWM mode.

Address Hex	Read/Write	Bits	POR Value	Name	Description
60	Read. (Write only if reg 4A bit 5 = 1)	7	0	E9T7	Lookup Table Temperature Entry 9
		6:0	0x7F	E9T6:E9T0	Bit 7 is unused and always set to 0 in the low resolution temperature LUT mode. In the high resolution temperature LUT mode bit 7 in conjunction with bits 6:0 of this register are used to determine the limit temperature that the remote diode temperature is compared to. In high resolution the range is 0°C to 127.5°C. In low resolution mode the range is 0°C to 127°C. If the remote diode temperature exceeds this value, the PWM output will be the value in Register 0x61. Only 9-bits of the temperature reading are used in high resolution and 8-bits in low resolution. Only positive temperature values can be programmed in this register and in all cases the sign bit is assumed to be zero. Temperatures greater than 127 °C or 127.5 °C can be programmed through the use of the Lookup Table Temperature Offset Register (4Eh).
7:6					
61	5:0	0x3F	E9D5:E9D0	Lookup Table PWM Duty Cycle Entry 9 The PWM value corresponding to the temperature limit in register 0x60 for the low resolution PWM mode.	
62	Read. (Write only if reg 4A bit 5 = 1)	7	0	E10T7	Lookup Table Temperature Entry 10
		6:0	0x7F	E10T6:E10T0	Bit 7 is unused and always set to 0 in the low resolution temperature LUT mode. In the high resolution temperature LUT mode bit 7 in conjunction with bits 6:0 of this register are used to determine the limit temperature that the remote diode temperature is compared to. In high resolution the range is 0°C to 127.5°C. In low resolution mode the range is 0°C to 127°C. If the remote diode temperature exceeds this value, the PWM output will be the value in Register 0x63. Only 9-bits of the temperature reading are used in high resolution and 8-bits in low resolution. Only positive temperature values can be programmed in this register and in all cases the sign bit is assumed to be zero. Temperatures greater than 127 °C or 127.5 °C can be programmed through the use of the Lookup Table Temperature Offset Register (4Eh).
7:6					
63	5:0	0x3F	E10D5:E10D0	Lookup Table PWM Duty Cycle Entry 10 The PWM value corresponding to the temperature limit in register 0x62 for the low resolution PWM mode.	

Address Hex	Read/Write	Bits	POR Value	Name	Description
64	Read. (Write only if reg 4A bit 5 = 1)	7	0	E11T7	Lookup Table Temperature Entry 11 Bit 7 is unused and always set to 0 in the low resolution temperature LUT mode.
		6:0	0x7F	E11T6:E11T0	In the high resolution temperature LUT mode bit 7 in conjunction with bits 6:0 of this register are used to determine the limit temperature that the remote diode temperature is compared to. In high resolution the range is 0°C to 127.5°C. In low resolution mode the range is 0°C to 127°C. If the remote diode temperature exceeds this value, the PWM output will be the value in Register 0x65. Only 9-bits of the temperature reading are used in high resolution and 8-bits in low resolution. Only positive temperature values can be programmed in this register and in all cases the sign bit is assumed to be zero. Temperatures greater than 127 °C or 127.5 °C can be programmed through the use of the Lookup Table Temperature Offset Register (4Eh).
65	Read. (Write only if reg 4A bit 5 = 1)	7:6	00	E11D7:E11D6	Lookup Table PWM Duty Cycle Extended Entry 11 These bits are unused and always set to 0 in the low resolution duty cycle LUT mode. In the high resolution duty cycle LUT mode these bits in association with bits 5:0 of this register are used for the PWM value associated with the temperature limit in register 0x64. These bits can only be activated when PWM frequency of 22.5kHz is chosen.
		5:0	0x3F	E11D5:E11D0	Lookup Table PWM Duty Cycle Entry 11 The PWM value corresponding to the temperature limit in register 0x64 for the low resolution PWM mode.
66	Read. (Write only if reg 4A bit 5 = 1)	7	0	E12T7	Lookup Table Temperature Entry 12 Bit 7 is unused and always set to 0 in the low resolution temperature LUT mode.
		6:0	0x7F	E12T6:E12T0	In the high resolution temperature LUT mode bit 7 in conjunction with bits 6:0 of this register are used to determine the limit temperature that the remote diode temperature is compared to. In high resolution the range is 0°C to 127.5°C. In low resolution mode the range is 0°C to 127°C. If the remote diode temperature exceeds this value, the PWM output will be the value in Register 0x67. Only 9-bits of the temperature reading are used in high resolution and 8-bits in low resolution. Only positive temperature values can be programmed in this register and in all cases the sign bit is assumed to be zero. Temperatures greater than 127 °C or 127.5 °C can be programmed through the use of the Lookup Table Temperature Offset Register (4Eh).
67	Read. (Write only if reg 4A bit 5 = 1)	7:6	00	E12D7:E12D6	Lookup Table PWM Duty Cycle Extended Entry 12 These bits are unused and always set to 0 in the low resolution duty cycle LUT mode. In the high resolution duty cycle LUT mode these bits in association with bits 5:0 of this register are used for the PWM value associated with the temperature limit in register 0x66. These bits can only be activated when PWM frequency of 22.5kHz is chosen.
		5:0	0x3F	E12D5:E12D0	Lookup Table PWM Duty Cycle Entry 12 The PWM value corresponding to the temperature limit in register 0x66 for the low resolution PWM mode.

Configuration Register					
Address Hex	Read/Write	Bits	POR Value	Name	Description
<b>03 (09)<sub>HEX</sub> CONFIGURATION REGISTER</b>					
03 (09)	R/W	7	0	ALTMSK	ALERT Mask 0: ALERT interrupts are enabled. 1: ALERT interrupts are masked, and the $\overline{\text{ALERT}}$ pin is always in a high impedance (open) state.
		6	0	STBY	Standby 0: the LM96063 is in operational mode, converting, comparing, and updating the PWM output continuously. 1: the LM96063 enters a low power standby mode. In standby, continuous conversions are stopped, but a conversion/comparison cycle may be initiated by writing any value to register 0x0F the One-shot Register. Operation of the PWM output in standby depends on the setting of bit 5 in this register.
		5	0	PWMDIS	PWM Disable in Standby 0: the LM96063's PWM output continues to output the current fan control signal while in STANDBY. 1: the PWM output is disabled (as defined by the PWM polarity bit) while in STANDBY.
	R	4:3	00	[Reserved]	This bit is unused and always read as 0.
	R/W	2	0	TCHEN	TACH Enable 0: disables the TACH input 1: enables the TACH input
		1	0	TCRITOV	T_CRIT Limit Override 0: locks the T_CRIT limit for the remote diode, POR setting is nominally 110°C 1: unlocks the T_CRIT limit and allows it to be reprogrammed multiple times
		0	0	FLTQUE	RDTs Fault Queue 0: an ALERT will be generated if any Remote Diode conversion result is above the <b>Remote High Set Point or below the Remote Low Setpoint</b> . 1: an ALERT will be generated only if three consecutive Remote Diode conversions are above the <b>Remote High Set Point or below the Remote Low Setpoint</b> .

#### Tachometer Count and Limit Registers

Address Hex	Read/Write	Bits	POR Value	Name	Description		
<b>47<sub>HEX</sub> TACHOMETER COUNT (MSB) and 46<sub>HEX</sub> TACHOMETER COUNT (LSB) REGISTERS (16 bits: Read LSB first to lock MSB and ensure MSB and LSB are from the same reading)</b>							
47	R	7:0	N/A	TAC13:TAC6	Tachometer Count (MSB and LSB)		
46	R	7:2	N/A	TAC5:TAC0	These registers contain the current 16-bit Tachometer Count, representing the period of time between tach pulses. Note that the 16-bit tachometer MSB and LSB register addresses are in reverse order from the 16 bit temperature readings.		
	R	1:0	00	TEDGE1:TEDGE0	Tachometer Edge Programming		
					<b>Bits</b>	<b>Edges Used</b>	<b>Tach_Count_Multiple</b>
					00:	Reserved - do not use	
					01:	2	4
10:	3	2					
11:	5	1					
Note: If PWM_Clock_Select = 360 kHz, then Tach_Count_Multiple = 1 regardless of the setting of these bits.							

Address Hex	Read/Write	Bits	POR Value	Name	Description
<b>49<sub>HEX</sub> TACHOMETER LIMIT (MSB) and 48<sub>HEX</sub> TACHOMETER LIMIT (LSB) REGISTERS</b>					
49	R/W	7:0	0xFF	TACL13:TACL6	Tachometer Limit (MSB and LSB)
48	R/W	7:2	0xFF	TACHL5:TACL0	These registers contain the current 14-bit Tachometer Count, representing the period of time between tach pulses. Fan RPM = (f * 5,400,000) / (Tachometer Count), where f = 1 for 2 pulses/rev fan; f = 2 for 1 pulse/rev fan; and f = 2/3 for 3 pulses/rev fan. See the Applications Notes section for more tachometer information. Note that the 16-bit tachometer MSB and LSB register addresses are in reverse order from the 16 bit temperature readings.
	R/W	1:0		[Reserved]	These bits are not used and write 0 or 1.
<b>Local Temperature and Local High Setpoint Registers</b>					
Address Hex	Read/Write	Bits	POR Value	Name	Description
<b>00<sub>HEX</sub> LOCAL TEMPERATURE REGISTER (8-bits)</b>					
00	R	7:0	N/A	LT7:LT0	Local Temperature Reading (8-bit) 8-bit integer representing the temperature of the LM96063 die. LT7 is the SIGN bit LT6 has a bit weight of 64°C LT5 has a bit weight of 32°C LT4 has a bit weight of 16°C LT3 has a bit weight of 8°C LT2 has a bit weight of 4°C LT1 has a bit weight of 2°C LT0 has a bit weight of 1°C
<b>05 (0B)<sub>HEX</sub> LOCAL HIGH SETPOINT REGISTER (8-bits)</b>					
05	R/W	7:0	0x46 (70°)	LHS7:LHS0	Local HIGH Setpoint High Setpoint for the internal diode. LHS7 is the SIGN bit LHS6 has a bit weight of 64°C LHS5 has a bit weight of 32°C LHS4 has a bit weight of 16°C LHS3 has a bit weight of 8°C LHS2 has a bit weight of 4°C LHS1 has a bit weight of 2°C LHS0 has a bit weight of 1°C
<b>Remote Diode Temperature, Offset and Setpoint Registers</b>					
Address Hex	Read/Write	Bits	POR Value	Name	Description
<b>01<sub>HEX</sub> AND 10<sub>HEX</sub> SIGNED REMOTE DIODE TEMPERATURE REGISTERS</b>					
01	R	7:0	N/A	RT12:RT5	Most Significant Byte of the Signed Remote Diode Temperature Reading The most significant 8-bits of the 2's complement value, representing the temperature of the remote diode connected to the LM96063. Bit 7 is the sign bit, bit 6 has a weight of 64°C, and bit 0 has a weight of 1°C. This byte to be read before the LSB.

Address Hex	Read/Write	Bits	POR Value	Name	Description
10	R	7:3	N/A	RT4:RT0	Least Significant Byte of the Signed Remote Diode Temperature Reading This is the LSB of the 2's complement value, representing the temperature of the remote diode connected to the LM96063. RT4 has a weight of 0.5°C, RT3 has a weight of 0.25°C, and RT2 has a weight of 0.125°C. If the digital filter is turned off RT1:RT0 have a value of 00 unless extended resolution (Reg 45h STFBE bit set) is enabled. If extended resolution is chosen, for readings greater than 127.875 RT1:RT0=11 and for other cases RT1:RT0=00. When the digital filter is turned on and extended resolution enabled: RT1 has a weight of 0.0625 and RT0 has a weight of 0.03125°C
		2:0	00	[Reserved]	These bits are unused and always read as 0.
<b>31<sub>HEX</sub> AND 32<sub>HEX</sub> UNSIGNED REMOTE DIODE TEMPERATURE REGISTERS</b>					
31	R	7:0	N/A	RTU12:RTU5	Most Significant Byte of the Unsigned Format Remote Diode Temperature Reading The most significant 8-bits of the unsigned format value, representing the temperature of the remote diode connected to the LM96063. Bit 7 has a weight of 128°C, bit 6 has a weight of 64°C, and bit 0 has a weight of 1°C. This byte to be read before the LSB.
32	R	7:3	N/A	RUT4:RUT0	Least Significant Byte of the Unsigned Format Remote Diode Temperature Reading This is the LSB of the unsigned value, representing the temperature of the remote diode connected to the LM96063. Bit 4 has a weight 0.5°C, bit 3 has a weight of 0.25°C, and bit 2 has a weight of 0.125°C. if the digital filter is turned off RUT1:RUT0 have a value of 00. When the digital filter is turned on: bit 1 has a weight of 0.0625 and bit 0 has a weight of 0.03125°C
		2:0	00	[Reserved]	These bits are unused and always read as 0.
<b>11<sub>HEX</sub> AND 12<sub>HEX</sub> REMOTE TEMPERATURE OFFSET REGISTERS</b>					
11	R/W	7:0	0x00	RTO10:RTO3	Remote Temperature Offset (MSB and LSB)
12	R/W	7:5	000	RTO2:RTO1	These registers contain the value added to or subtracted from the remote diode's reading to compensate for the different non-ideality factors of different processors, diodes, etc. The 2's complement value, in these registers is added to the output of the LM96063's ADC to form the temperature reading contained in registers 01 and 10. These registers have the same format as the MSB and LSB Remote Diode Temperature Reading registers with the digital filter off.
	R	4:0	000	[Reserved]	These bits are not used and always read as 0.
<b>07 (0D)<sub>HEX</sub> AND 13<sub>HEX</sub> REMOTE HIGH SETPOINT REGISTERS</b>					
07 (0D)	R/W	7:0	0x69 (105°C)	RHS10:RHS3	Remote HIGH Setpoint (MSB and LSB) High setpoint temperature for remote diode. Same format as <b>Unsigned Remote Temperature Reading</b> (registers 31 and 32) or <b>Signed Remote Temperature Reading</b> (registers 01 and 10) with the digital filter off. Is it programmable by the USF bit found in the Enhanced configuration Register.
13	R/W	7:5	000	RHS2:RHS0	
	R	4:0	0x00	[Reserved]	These bits are not used and always read as 0.
<b>08 (0E)<sub>HEX</sub> AND 14<sub>HEX</sub> REMOTE LOW SETPOINT REGISTERS</b>					
08 (0E)	R/W	7:0	00 (0°C)	RTS10:RTS3	Remote LOW Setpoint (MSB and LSB) Low setpoint temperature for remote diode. Same format as <b>Signed Remote Temperature Reading</b> (registers 01 and 10) with the digital filter off.
14	R/W	7:5	000	RTS2:RTS0	
	R	4:0	0x00	[Reserved]	These bits are not used and always read as 0.

Address Hex	Read/Write	Bits	POR Value	Name	Description
<b>19<sub>HEX</sub> REMOTE DIODE T_CRIT SETPOINT REGISTER</b>					
19	R/W	7:0	0x6E (110°C)	RCS7:RCS0	<p>Remote Diode T_CRIT Setpoint Limit</p> <p>This 8-bit integer stores the T_CRIT limit and is nominally 110°C. The value of this register can be locked by setting T_CRIT Limit Override (bit 1) in the Configuration register to a 0, then programming a new T_CRIT value into this register. The format of this register is programmable. When the USF bit in the Enhanced Configuration register is cleared:</p> <p>LCS7 is the SIGN bit</p> <p>LCS6 has a bit weight of 64°C</p> <p>LCS5 has a bit weight of 32°C</p> <p>LCS4 has a bit weight of 16°C</p> <p>LCS3 has a bit weight of 8°C</p> <p>LCS2 has a bit weight of 4°C</p> <p>LCS1 has a bit weight of 2°C</p> <p>LCS0 has a bit weight of 1°C</p>
<b>21<sub>HEX</sub> T_CRIT HYSTERESIS REGISTER</b>					
21	R/W	7	0x0A (10°C)	RTH7	This bit is unused. OK to write 1 or 0.
		6:0		RTH6:RTH0	<p>Remote Diode T_CRIT Hysteresis</p> <p>T_CRIT stays activated until the remote diode temperature goes below [(T_CRIT Limit)—(T_CRIT Hysteresis)].</p> <p>RTH6 has a bit weight of 64°C</p> <p>RTH5 has a bit weight of 32°C</p> <p>RTH4 has a bit weight of 16°C</p> <p>RTH3 has a bit weight of 8°C</p> <p>RTH2 has a bit weight of 4°C</p> <p>RTH1 has a bit weight of 2°C</p> <p>RTH0 has a bit weight of 1°C</p>
<b>BF<sub>HEX</sub> REMOTE DIODE TEMPERATURE FILTER AND COMPARATOR MODE</b>					
BF	R/W	7:6	00	[Reserved]	These bits are unused and always write 0.
	R	5:3	000	[Reserved]	These bits are unused and always read as 0.
	R/W	2:1	00	RDTF1:RDTF0	<p>Remote Diode Temperature Filter Control</p> <p>00: Filter Disabled</p> <p>01: Filter Level 2 (minimal filtering, same as 10; Like LM63, LM63 Level 1 not supported)</p> <p>10: Filter Level 2 (minimal filtering, same as 01; like LM63, LM63 Level 1 not supported)</p> <p>11: Filter Enhanced Level 2 (maximum filtering)</p>
		0	0	ALT/CMP	<p>Comparator Mode</p> <p>0: the <math>\overline{\text{ALERT}}</math> pin functions normally.</p> <p>1: the <math>\overline{\text{ALERT}}</math> pin behaves as a comparator, asserting itself when an ALERT condition exists, de-asserting itself when the ALERT condition goes away.</p>

## ALERT Status and Mask Registers

Address Hex	Read/Write	Bits	POR Value	Name	Description
<b>02<sub>HEX</sub> ALERT STATUS REGISTER (8-bits) (All Alarms are latched until read, then cleared if alarm condition was removed at the time of the read.)</b>					
0x02	R	7	0	BUSY	Busy 0: the ADC is not converting. 1: the ADC is performing a conversion. This bit does not affect ALERT status.
		6	0	LHIGH	Local High Alarm 0: the internal temperature of the LM96063 is at or below the Local High Setpoint. 1: the internal temperature of the LM96063 is above the Local High Setpoint, and an ALERT is triggered.
		5	0	[Reserved]	This bit is unused and always read as 0.
		4	0	RHIGH	Remote High Alarm 0: the temperature of the Remote Diode is at or below the Remote High Setpoint. 1: the temperature of the Remote Diode is above the Remote High Setpoint, and an ALERT is triggered.
		3	0	RLOW	Remote Low Alarm 0: the temperature of the Remote Diode is at or above the Remote Low Setpoint. 1: the temperature of the Remote Diode is below the Remote Low Setpoint, and an ALERT is triggered.
		2	0	RDFA	Remote Diode Fault Alarm 0: the Remote Diode appears to be correctly connected. 1: the Remote Diode may be disconnected or shorted to ground. This Alarm does not trigger an ALERT or a TCRT.
		1	0	RCRIT	Remote T_CRIT Alarm When this bit is a 0, the temperature of the Remote Diode is at or below the T_CRIT Limit. When this bit is a 1, the temperature of the Remote Diode is above the T_CRIT Limit, ALERT and TCRT are triggered.
		0	0	TACH	Tach Alarm When this bit is a 0, the Tachometer count is lower than or equal to the Tachometer Limit (the RPM of the fan is greater than or equal to the minimum desired RPM). When this bit is a 1, the Tachometer count is higher than the Tachometer Limit (the RPM of the fan is less than the minimum desired RPM), and an ALERT is triggered.

Address Hex	Read/Write	Bits	POR Value	Name	Description
<b>16<sub>HEX</sub> ALERT MASK REGISTER (8-bits)</b>					
16	R	7	1	[Reserved]	This bit is unused and always read as 1.
	R/W	6	0	LHAM	Local High Alarm Mask 0: a Local High Alarm event will generate an ALERT. 1: a Local High Alarm will not generate an ALERT
	R	5	1	[Reserved]	This bit is unused and always read as 1.
	R/W	4	0	RHAM	Remote High Alarm Mask 0: Remote High Alarm event will generate an ALERT. 1: a Remote High Alarm event will not generate an ALERT.
		3	0	RLAM	Remote Low Alarm Mask 0: a Remote Low Alarm event will generate an ALERT. 1: a Remote Low Alarm event will not generate an ALERT.
	R	2	1	[Reserved]	This bit is unused and always read as 1.
	R/W	1	0	RTAM	Remote T_CRIT Alarm Mask 0: a Remote T_CRIT event will generate an ALERT. 1: a Remote T_CRIT event will not generate an ALERT.
		0	0	TCHAM	TACH Alarm Mask When this bit is a 0, a Tach Alarm event will generate an ALERT. When this bit is a 1, a Tach Alarm event will not generate an ALERT.
<b>33<sub>HEX</sub> POWER ON RESET STATUS REGISTER</b>					
33	R	7	—	NR	Power On Reset Status 0: Power On Reset cycle over part ready 1: Power On Reset cycle in progress part not ready
		6:0		[Reserved]	These bits are unused and will always report 0.
<b>Conversion Rate and One-Shot Registers</b>					
Address Hex	Read/Write	Bits	POR Value	Name	Description
<b>04 (0A)<sub>HEX</sub> CONVERSION RATE REGISTER (8-bits)</b>					
04 (0A)	R	7:4	0x08	[Reserved]	These bits are unused and will always be set to 0.
	R/W	3:0		CONV3:CONV0	Conversion Rate Sets the conversion rate of the LM96063. 0000 = 0.05 Hz 0001 = 0.1 Hz 0010 = 0.204 Hz 0011 = 0.406 Hz 0100 = 0.813 Hz 0101 = 1.625 Hz 0110 = 3.25 Hz 0111 = 6.5 Hz 1000 = 13 Hz 1001 = 26 Hz All other values = 26 Hz
<b>0F<sub>HEX</sub> ONE-SHOT REGISTER (8-bits)</b>					
0F	Write Only	7:0	N/A		One Shot Trigger With the LM96063 in the STANDBY mode a single write to this register will initiate one complete temperature conversion cycle. Any value may be written.

## ID Registers

Address Hex	Read/Write	Bits	POR Value	Name	Description
<b>FE<sub>HEX</sub> MANUFACTURER'S ID REGISTER (8-bits)</b>					
FE	R	7:0	0x01	Manufacturer's ID	0x01 = National Semiconductor
<b>FF<sub>HEX</sub> STEPPING / DIE REVISION ID REGISTER (8-bits)</b>					
FF	R	7:0	0x49	Stepping/Die Revision ID	Version of LM96063

### 3.0 Application Notes

#### 3.1 FAN CONTROL DUTY CYCLE VS. REGISTER SETTINGS AND FREQUENCY

The following table is true only when the 22.5 kHz PWM frequency high resolution duty cycle is not selected.

PWM Freq 4D [4:0]	Step Resolution, %	PWM Value 4C [5:0] for 100%	PWM Value 4C [5:0] for about 75%	PWM Value 4C [5:0] for 50%	PWM Freq at 360 kHz Internal Clock, kHz	PWM Freq at 1.4 kHz Internal Clock, Hz	Actual Duty Cycle, % When 75% is Selected
0	Address 0 is mapped to Address 1						
1	50	2	1	1	180.0	703.1	50.0
2	25	4	3	2	90.00	351.6	75.0
3	16.7	6	5	3	60.00	234.4	83.3
4	12.5	8	6	4	45.00	175.8	75.0
5	10.0	10	8	5	36.00	140.6	80.0
6	8.33	12	9	6	30.00	117.2	75.0
7	7.14	14	11	7	25.71	100.4	78.6
8	6.25	16	12	8	22.50	87.9	75.0
9	5.56	18	14	9	20.00	78.1	77.8
10	5.00	20	15	10	18.00	70.3	75.0
11	4.54	22	17	11	16.36	63.9	77.27
12	4.16	24	18	12	15.00	58.6	75.00
13	3.85	26	20	13	13.85	54.1	76.92
14	3.57	28	21	14	12.86	50.2	75.00
15	3.33	30	23	15	12.00	46.9	76.67
16	3.13	32	24	16	11.25	43.9	75.00
17	2.94	34	26	17	10.59	41.4	76.47
18	2.78	36	27	18	10.00	39.1	75.00
19	2.63	38	29	19	9.47	37.0	76.32
20	2.50	40	30	20	9.00	35.2	75.00
21	2.38	42	32	21	8.57	33.5	76.19
22	2.27	44	33	22	8.18	32.0	75.00
23	2.17	46	35	23	7.82	30.6	76.09
24	2.08	48	36	24	7.50	29.3	75.00
25	2.00	50	38	25	7.20	28.1	76.00
26	1.92	52	39	26	6.92	27.0	75.00
27	1.85	54	41	27	6.67	26.0	75.93
28	1.79	56	42	28	6.42	25.1	75.00
29	1.72	58	44	29	6.21	24.2	75.86
30	1.67	60	45	30	6.00	23.4	75.00
31	1.61	62	47	31	5.81	22.7	75.81

The following table is true only when the 22.5 kHz PWM frequency with high resolution duty cycle is selected by setting bit 4 (PHR) of the Enhanced Configuration register (0x45), clearing bit 3 (PWCKSL) of the PWM and RPM Configuration register (0x4A) and setting PWM Frequency (0x4D) register to 0x08.

PWM Freq 4D [4:0]	Step Resolution, %	PWM Value 4C [7:0] for 100% (Hex)	PWM Value 4C [7:0] for about 75% (Hex)	PWM Value 4C [7:0] for 50% (Hex)	PWM Freq at 360 kHz Internal Clock, kHz	PWM Freq at 1.4 kHz Internal Clock, Hz	Actual Duty Cycle, % When Approximately 75% is Selected
8	0.392	FF	BF	80	22.50	Not Available	74.902

**3.1.1 Computing Duty Cycles for a Given Frequency**

Select a PWM Frequency from the first column corresponding to the desired actual frequency in columns 6 or 7. Note the PWM Value for 100% Duty Cycle.

Find the Duty Cycle by taking the PWM Value of Register 4C and computing:

$$DutyCycle \_ (%) = \frac{PWM \_ Value}{PWM \_ Value \_ for \_ 100\%} \times 100 \%$$

Example: For a PWM Frequency of 24, a PWM Value at 100% = 48 and PWM Value actual = 28, then the Duty Cycle is  $(28/48) \times 100\% = 58.3\%$ .

**3.2 LUT FAN CONTROL**

The LM96063 fan control uses a temperature to duty cycle look-up table (LUT) that has 12 indexes. High resolution duty cycle (0.392%) is available when the PWM frequency is set to 22.5 kHz. In addition ramp rate control is available to acoustically smooth the duty cycle transition between LUT steps.

Shown in Figure 7(a) is an example of the 12-point LUT temperature to PWM transfer function that can be realized without smoothing enabled. The table is comprised of twelve Duty-Cycle and Temperature set-point pairs. Notice that the transitions between one index of the LUT to the next happen instantaneously. If the PWM levels are set far enough apart this can be acoustically very disturbing. The typical acoustical threshold of change in duty cycle is 2%. Figure 7(b) has an overlaid curve (solid line) showing what occurs at the transitions when smoothing is enabled. The dashed lines shown in Figure 7(b) are there to point out that multiple slopes can be

realized easily. At the transitions the duty cycle increments in LSB (0.39% for the case shown) steps. In the example shown in Figure 7(b) the first pair is set for a duty-cycle of 31.25% and a temperature of 0°C. For temperatures less than 0°C the duty cycle is set to 0. When the temperature is greater than 0°C but is less than 91°C the duty cycle will remain at 31.25%. The next pair is set at 37.5% and 91°C. Once the temperature exceeds 91°C the duty cycle on the PWM output will gradually transition from 31.25% to 37.5% in 0.39% steps at the programmed time interval. The LUT comparison temperature resolution is programmable to either 1°C or 0.5°C. For the curves of Figure 7 the comparison resolution is set to 0.5°C that is why the actual duty cycle transitions happen 0.5°C higher than the actual LUT entry. The duty cycle transition time interval is programmable and is shown in the table titled PWM Smoothing Time Intervals. Care should be taken so that the LUT PWM and Temperature values are setup in ascending weight.

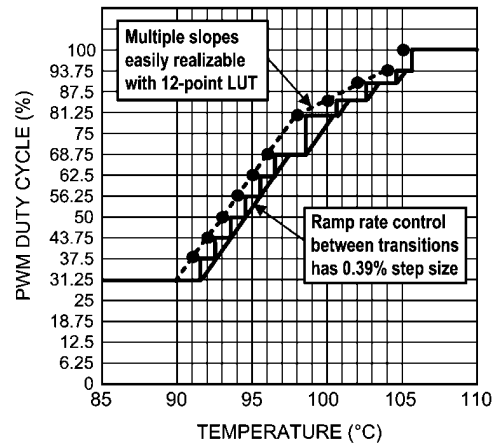
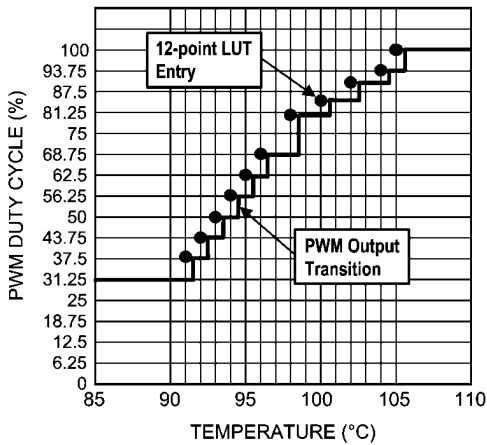

(a) Without smoothing (b) With smoothing  
**FIGURE 7. Fan Control Transfer Function Example**

Also included is programmable hysteresis that is not described by the curves of [Figure 7](#). The hysteresis takes effect as temperature is decreasing and moves all the temperature set-points down by the programmed amount. For the example shown here if the hysteresis is set to 1°C and if the temperature is decreasing from 96.5°C the duty cycle will remain at 68.75% and will not transition to 62.5% until the temperature drops below 95.5°C.

If at any time the TCRIT output were to activate the PWM duty cycle will be instantaneously forced to 100% thus forcing the fans to full on.

#### PWM Smoothing Time Intervals

Time Interval (seconds)	0-100% DC Time	
	w/ 6.25% resolution (seconds)	w/ 0.39% resolution Seconds
0.182	2.913	43.7
0.091	1.456	21.6
0.046	0.728	10.9
0.023	0.364	5.45

The [PWM Smoothing Time Intervals](#) table describes the programmable time interval preventing abrupt changes in the PWM output duty cycle and thus preventing abrupt acoustical noise changes as well. The threshold of acoustically detecting fan noise transition is at about a 2% duty cycle change. The table describes the time intervals that can be programmed and the total amount of time it will take for the PWM output to change from 0% to 100% for each time interval. For example if the time interval for each step is set to 0.091 seconds the time it will take to make a 0 to 100% duty cycle change will be 21.6 seconds when the duty cycle resolution is set to 0.39% or 1.46 seconds when the resolution is 6.25%. One setting will apply to all LUT transitions.

### 3.3 COMPUTING RPM OF THE FAN FROM THE TACH COUNT

The Tach Count Registers 46<sub>HEX</sub> and 47<sub>HEX</sub> count the number of periods of the 90 kHz tachometer clock in the LM96063 for the tachometer input from the fan assuming a 2 pulse per revolution fan tachometer, such as the fans supplied with the Intel boxed processors. The RPM of the fan can be computed from the Tach Count Registers 46<sub>HEX</sub> and 47<sub>HEX</sub>. This can best be shown through an example.

Example:

Given: the fan used has a tachometer output with 2 per revolution.

Let:

Register 46 (LSB) is BF<sub>HEX</sub> = Decimal (11 x 16) + 15 = 191 and

Register 47 (MSB) is 7<sub>HEX</sub> = Decimal (7 x 256) = 1792.

The total Tach Count, in decimal, is 191 + 1792 = **1983**.

The RPM is computed using the formula

$$\text{Fan \_ RPM} = \frac{f \times 5,400,000}{\text{Total \_ Tach \_ Count \_ (Decimal)}}$$

where

f = 1 for 2 pulses/rev fan tachometer output;

f = 2 for 1 pulse/rev fan tachometer output, and

f = 2 / 3 for 3 pulses/rev fan tachometer output

For our example

$$\text{Fan \_ RPM} = \frac{1 \times 5,400,000}{1983} = 2723 \_ \text{RPM}$$

### 3.4 DIODE NON-IDEALITY

The LM96063 can be applied easily in the same way as other integrated-circuit temperature sensors, and its remote diode sensing capability allows it to be used in new ways as well. It can be soldered to a printed circuit board, and because the path of best thermal conductivity is between the die and the pins, its temperature will effectively be that of the printed circuit board lands and traces soldered to the LM96063's pins. This presumes that the ambient air temperature is almost the same as the surface temperature of the printed circuit board; if the air temperature is much higher or lower than the surface temperature, the actual temperature of the LM96063 die will be at an intermediate temperature between the surface and air temperatures. Again, the primary thermal conduction path is through the leads, so the circuit board temperature will contribute to the die temperature much more strongly than will the air temperature.

The LM96063 incorporates remote diode temperature sensing technology allowing the measurement of remote temperatures. This diode can be located on the die of a target IC, allowing measurement of the IC's temperature, independent of the LM96063's die temperature. A discrete diode can also be used to sense the temperature of external objects or ambient air. Remember that a discrete diode's temperature will be affected, and often dominated, by the temperature of its leads. Most silicon diodes do not lend themselves well to this application. It is recommended that an MMBT3904 transistor base emitter junction be used with the collector tied to the base.

The LM96063 can measure a diode-connected transistor such as the MMBT3904 or the thermal diode found in an AMD processor or any other device (ASIC, CPU or FPGA) built on an SOI process accurately.

#### 3.4.1 Diode Non-Ideality Factor Effect on Accuracy

When a transistor is connected as a diode, the following relationship holds for variables V<sub>BE</sub>, T and I<sub>F</sub>:

$$I_F = I_S \times \left[ e^{\left( \frac{V_{BE}}{\eta \times V_t} \right)} - 1 \right] \quad (1)$$

where:

$$V_t = \frac{kT}{q}$$

- q = 1.6×10<sup>-19</sup> Coulombs (the electron charge),
- T = Absolute Temperature in Kelvin
- k = 1.38×10<sup>-23</sup> joules/K (Boltzmann's constant),
- η is the non-ideality factor of the process the diode is manufactured on,
- I<sub>S</sub> = Saturation Current and is process dependent,
- I<sub>F</sub> = Forward Current through the base-emitter junction
- V<sub>BE</sub> = Base-Emitter Voltage drop

In the active region, the -1 term is negligible and may be eliminated, yielding the following equation

$$I_F = I_S \times \left[ e^{\left( \frac{V_{BE}}{\eta \times V_T} \right)} \right] \tag{2}$$

In Equation 2,  $\eta$  and  $I_S$  are dependant upon the process that was used in the fabrication of the particular diode. By forcing two currents with a very controlled ratio ( $I_{F2} / I_{F1}$ ) and measuring the resulting voltage difference, it is possible to eliminate the  $I_S$  term. Solving for the forward voltage difference yields the relationship:

$$\Delta V_{BE} = \eta \times \left( \frac{kT}{q} \right) \times \ln \left( \frac{I_{F2}}{I_{F1}} \right) \tag{3}$$

Solving Equation 3 for temperature yields:

$$T = \frac{q \times \Delta V_{BE}}{\eta \times k \times \ln \left( \frac{I_{F2}}{I_{F1}} \right)} \tag{4}$$

Equation 4 holds true when a diode connected transistor such as the MMBT3904 is used. When this “diode” equation is applied to an integrated diode such as a processor transistor with its collector tied to GND as shown in it may yield a wide non-ideality spread. This wide non-ideality spread is not due to true process variation but due to the fact that Equation 4 is an approximation.

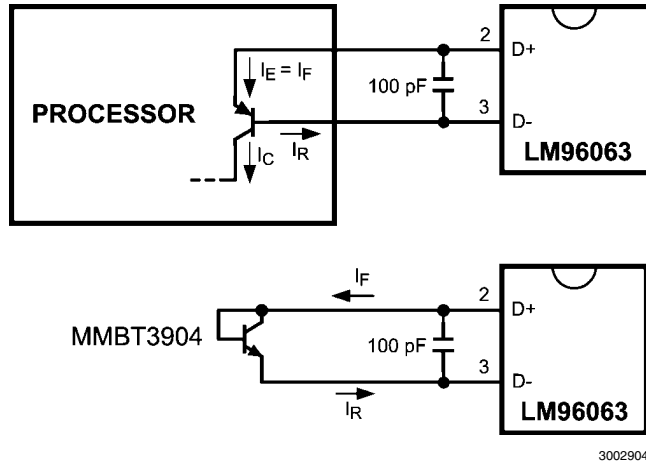

30029043

FIGURE 8. Thermal Diode Current Paths

### 3.4.2 Calculating Total System Accuracy

The voltage seen by the LM96063 also includes the  $I_F R_S$  voltage drop of the series resistance. The non-ideality factor,  $\eta$ , is the only other parameter not accounted for and depends on the diode that is used for measurement. Since  $\Delta V_{BE}$  is proportional to both  $\eta$  and  $T$ , the variations in  $\eta$  cannot be distinguished from variations in temperature. Since the non-ideality factor is not controlled by the temperature sensor, it will directly add to the inaccuracy of the sensor. As an example, assume a temperature sensor has an accuracy specification of  $\pm 1.0^\circ\text{C}$  at a temperature of  $80^\circ\text{C}$  (353 Kelvin) and the processor diode has a non-ideality variation of  $\pm 0.39\%$ . The resulting system accuracy of the processor temperature being sensed will be:

$$T_{ACC} = \pm 0.75^\circ\text{C} + (\pm 0.39\% \text{ of } 353 \text{ K}) = \pm 2.16^\circ\text{C}$$

The next error term to be discussed is that due to the series resistance of the thermal diode and printed circuit board traces. The thermal diode series resistance is specified on most processor data sheets and is in the range of several ohms. The LM96063 does not need to be compensated for series resistance errors if the manufacturer of the thermal diode says that the diode they provide matches the performance of an MMBT3904. If they provide a typical series resistance number that does not have to be compensated for because it is taken into account. The error that is not accounted for is the spread of the processor's series resistance and additional PCB trace resistance. The equation used to calculate the temperature error ( $T_{ER}$ ) due to thermal diode series resistance variation is simply:

$$T_{ER} = \left( 0.62 \frac{^\circ\text{C}}{\Omega} \right) \times R_{PCB} \quad (5)$$

Solving Equation 5 for  $R_{PCB}$  equal to  $-1.5\Omega$  to  $2.5\Omega$  results in the additional error due to the spread in this series resistance of  $-0.93^\circ\text{C}$  to  $+1.55^\circ\text{C}$ . The spread in error cannot be canceled out, as it would require measuring each individual thermal diode device. This is quite difficult and impractical in a large volume production environment.

Equation 5 can also be used to calculate the additional error caused by series resistance on the printed circuit board. Since the variation of the PCB series resistance is minimal, the bulk of the error term is always positive and can simply be cancelled out by subtracting it from the output readings of the LM96063 using the Remote Temperature Offset register.

### 3.5 PCB LAYOUT FOR MINIMIZING NOISE

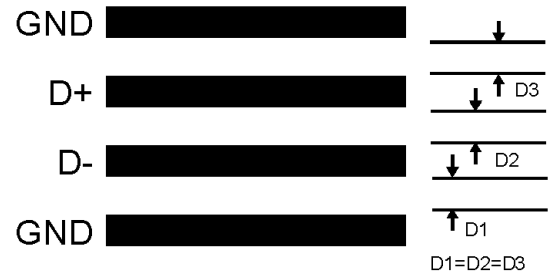

30029021

FIGURE 9. Ideal Diode Trace Layout

In a noisy environment, such as a processor mother board, layout considerations are very critical. Noise induced on traces running between the remote temperature diode sensor and the LM96063 can cause temperature conversion errors. Keep in mind that the signal level the LM96063 is trying to measure is in microvolts. The following guidelines should be followed:

1. Use a low-noise +3.3VDC power supply, and bypass to GND with a  $0.1 \mu\text{F}$  ceramic capacitor in parallel with a  $100 \text{ pF}$  ceramic capacitor. The  $100 \text{ pF}$  capacitor should be placed as close as possible to the power supply pin. A bulk capacitance of  $10 \mu\text{F}$  needs to be in the vicinity of the LM96063's  $V_{DD}$  pin.
2. A  $100 \text{ pF}$  diode bypass capacitor is recommended to filter high frequency noise but may not be necessary. Place the recommended  $100 \text{ pF}$  diode capacitor as close as possible to the LM96063's D+ and D- pins. Make sure the traces to the  $100 \text{ pF}$  capacitor are matched. The LM96063 can handle capacitance up to  $3 \text{ nF}$  placed between the D+ and D- pins. See Typical Performance Characteristic curves titled *Remote Temperature Reading Sensitivity to Thermal Diode Filter Capacitance*.
3. Ideally, the LM96063 should be placed within  $10 \text{ cm}$  of the Processor diode pins with the traces being as straight, short and identical as possible. Trace resistance of  $1 \Omega$  can cause as much as  $0.62^\circ\text{C}$  of error. This error can be compensated by using the Remote Temperature Offset Registers, since the value placed in these registers will automatically be subtracted from or added to the remote temperature reading.
4. Diode traces should be surrounded by a GND guard ring to either side, above and below if possible. This GND guard should not be between the D+ and D- lines. In the event that noise does couple to the diode lines it would be ideal if it is coupled common mode. That is equally to the D+ and D- lines.
5. Avoid routing diode traces in close proximity to power supply switching or filtering inductors.
6. Avoid running diode traces close to or parallel to high speed digital and bus lines. Diode traces should be kept at least  $2 \text{ cm}$  apart from the high speed digital traces.
7. If it is necessary to cross high speed digital traces, the diode traces and the high speed digital traces should cross at a  $90$  degree angle.
8. The ideal place to connect the LM96063's GND pin is as close as possible to the Processor's GND associated with the sense diode.

9. Leakage current between D+ and GND should be kept to a minimum. Thirteen nano-amperes of leakage can cause as much as 0.2°C of error in the diode temperature reading. Keeping the printed circuit board as clean as possible will minimize leakage current.

Noise coupling into the digital lines greater than 400 mVp-p (typical hysteresis) and undershoot less than 500 mV below GND, may prevent successful SMBus communication with the LM96063. SMBus no acknowledge is the most common symptom, causing unnecessary traffic on the bus. Although the SMBus maximum frequency of communication is rather

low (100 kHz max), care still needs to be taken to ensure proper termination within a system with multiple parts on the bus and long printed circuit board traces. An RC lowpass filter with a 3 dB corner frequency of about 40 MHz is included on the LM96063's SMBCLK input. Additional resistance can be added in series with the SMBDAT and SMBCLK lines to further help filter noise and ringing. Minimize noise coupling by keeping digital traces out of switching power supply areas as well as ensuring that digital lines containing high speed data communications cross at right angles to the SMBDAT and SMBCLK lines.

**Physical Dimensions** inches (millimeters) unless otherwise noted

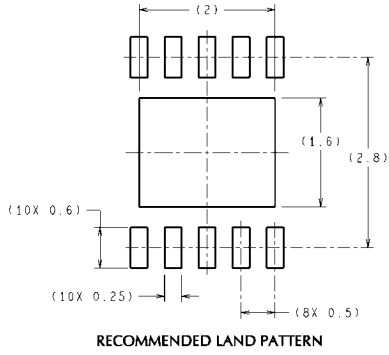

DIMENSIONS ARE IN MILLIMETERS  
DIMENSIONS IN ( ) FOR REFERENCE ONLY

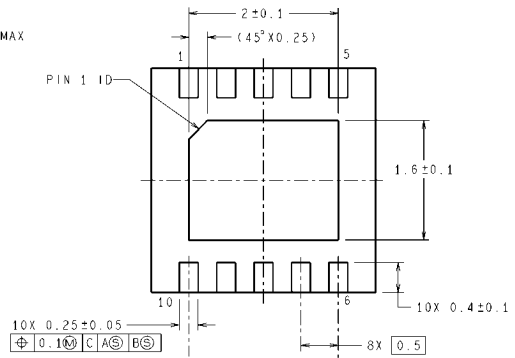
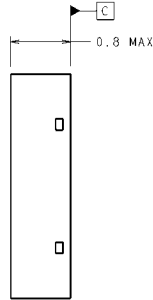
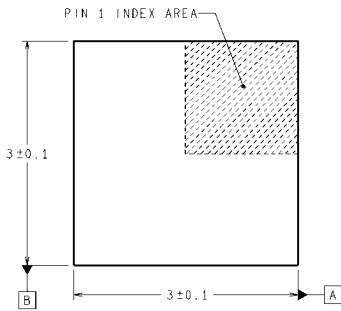
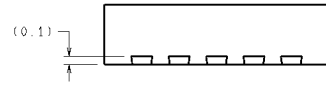

SDA10A (Rev A)

**10-Lead Lead Less Package (LLP or QFN)**  
**JEDEC Registration Number MO-299-WEED-5**  
**Order Number LM96063CISD or LM96063CISDX**  
**NS Package Number SDA10A**

# Notes

LM96063

## Notes

---

### TI/NATIONAL INTERIM IMPORTANT NOTICE

---

Texas Instruments has purchased National Semiconductor. As of Monday, September 26th, and until further notice, products sold or advertised under the National Semiconductor name or logo, and information, support and interactions concerning such products, remain subject to the preexisting National Semiconductor standard terms and conditions of sale, terms of use of website, and Notices (and/or terms previously agreed in writing with National Semiconductor, where applicable) and are not subject to any differing terms and notices applicable to other TI components, sales or websites. To the extent information on official TI and National websites and business social networking media, etc., pertains to both TI and National-branded products, both companies' instructions, warnings and limitations in the above-referenced terms of use apply.

Following are URLs where you can obtain information on other Texas Instruments products and application solutions:

Products		Applications	
Audio	<a href="http://www.ti.com/audio">www.ti.com/audio</a>	Communications and Telecom	<a href="http://www.ti.com/communications">www.ti.com/communications</a>
Amplifiers	<a href="http://amplifier.ti.com">amplifier.ti.com</a>	Computers and Peripherals	<a href="http://www.ti.com/computers">www.ti.com/computers</a>
Data Converters	<a href="http://dataconverter.ti.com">dataconverter.ti.com</a>	Consumer Electronics	<a href="http://www.ti.com/consumer-apps">www.ti.com/consumer-apps</a>
DLP® Products	<a href="http://www.dlp.com">www.dlp.com</a>	Energy and Lighting	<a href="http://www.ti.com/energy">www.ti.com/energy</a>
DSP	<a href="http://dsp.ti.com">dsp.ti.com</a>	Industrial	<a href="http://www.ti.com/industrial">www.ti.com/industrial</a>
Clocks and Timers	<a href="http://www.ti.com/clocks">www.ti.com/clocks</a>	Medical	<a href="http://www.ti.com/medical">www.ti.com/medical</a>
Interface	<a href="http://interface.ti.com">interface.ti.com</a>	Security	<a href="http://www.ti.com/security">www.ti.com/security</a>
Logic	<a href="http://logic.ti.com">logic.ti.com</a>	Space, Avionics and Defense	<a href="http://www.ti.com/space-avionics-defense">www.ti.com/space-avionics-defense</a>
Power Mgmt	<a href="http://power.ti.com">power.ti.com</a>	Transportation and Automotive	<a href="http://www.ti.com/automotive">www.ti.com/automotive</a>
Microcontrollers	<a href="http://microcontroller.ti.com">microcontroller.ti.com</a>	Video and Imaging	<a href="http://www.ti.com/video">www.ti.com/video</a>
RFID	<a href="http://www.ti-rfid.com">www.ti-rfid.com</a>	Wireless	<a href="http://www.ti.com/wireless-apps">www.ti.com/wireless-apps</a>
RF/IF and ZigBee® Solutions	<a href="http://www.ti.com/lprf">www.ti.com/lprf</a>	<b>TI E2E Community Home Page</b>	<a href="http://e2e.ti.com">e2e.ti.com</a>

Mailing Address: Texas Instruments, Post Office Box 655303, Dallas, Texas 75265

Copyright© 2011 Texas Instruments Incorporated

## IMPORTANT NOTICE

Texas Instruments Incorporated and its subsidiaries (TI) reserve the right to make corrections, modifications, enhancements, improvements, and other changes to its products and services at any time and to discontinue any product or service without notice. Customers should obtain the latest relevant information before placing orders and should verify that such information is current and complete. All products are sold subject to TI's terms and conditions of sale supplied at the time of order acknowledgment.

TI warrants performance of its hardware products to the specifications applicable at the time of sale in accordance with TI's standard warranty. Testing and other quality control techniques are used to the extent TI deems necessary to support this warranty. Except where mandated by government requirements, testing of all parameters of each product is not necessarily performed.

TI assumes no liability for applications assistance or customer product design. Customers are responsible for their products and applications using TI components. To minimize the risks associated with customer products and applications, customers should provide adequate design and operating safeguards.

TI does not warrant or represent that any license, either express or implied, is granted under any TI patent right, copyright, mask work right, or other TI intellectual property right relating to any combination, machine, or process in which TI products or services are used. Information published by TI regarding third-party products or services does not constitute a license from TI to use such products or services or a warranty or endorsement thereof. Use of such information may require a license from a third party under the patents or other intellectual property of the third party, or a license from TI under the patents or other intellectual property of TI.

Reproduction of TI information in TI data books or data sheets is permissible only if reproduction is without alteration and is accompanied by all associated warranties, conditions, limitations, and notices. Reproduction of this information with alteration is an unfair and deceptive business practice. TI is not responsible or liable for such altered documentation. Information of third parties may be subject to additional restrictions.

Resale of TI products or services with statements different from or beyond the parameters stated by TI for that product or service voids all express and any implied warranties for the associated TI product or service and is an unfair and deceptive business practice. TI is not responsible or liable for any such statements.

TI products are not authorized for use in safety-critical applications (such as life support) where a failure of the TI product would reasonably be expected to cause severe personal injury or death, unless officers of the parties have executed an agreement specifically governing such use. Buyers represent that they have all necessary expertise in the safety and regulatory ramifications of their applications, and acknowledge and agree that they are solely responsible for all legal, regulatory and safety-related requirements concerning their products and any use of TI products in such safety-critical applications, notwithstanding any applications-related information or support that may be provided by TI. Further, Buyers must fully indemnify TI and its representatives against any damages arising out of the use of TI products in such safety-critical applications.

TI products are neither designed nor intended for use in military/aerospace applications or environments unless the TI products are specifically designated by TI as military-grade or "enhanced plastic." Only products designated by TI as military-grade meet military specifications. Buyers acknowledge and agree that any such use of TI products which TI has not designated as military-grade is solely at the Buyer's risk, and that they are solely responsible for compliance with all legal and regulatory requirements in connection with such use.

TI products are neither designed nor intended for use in automotive applications or environments unless the specific TI products are designated by TI as compliant with ISO/TS 16949 requirements. Buyers acknowledge and agree that, if they use any non-designated products in automotive applications, TI will not be responsible for any failure to meet such requirements.

Following are URLs where you can obtain information on other Texas Instruments products and application solutions:

### Products

Audio	<a href="http://www.ti.com/audio">www.ti.com/audio</a>
Amplifiers	<a href="http://amplifier.ti.com">amplifier.ti.com</a>
Data Converters	<a href="http://dataconverter.ti.com">dataconverter.ti.com</a>
DLP® Products	<a href="http://www.dlp.com">www.dlp.com</a>
DSP	<a href="http://dsp.ti.com">dsp.ti.com</a>
Clocks and Timers	<a href="http://www.ti.com/clocks">www.ti.com/clocks</a>
Interface	<a href="http://interface.ti.com">interface.ti.com</a>
Logic	<a href="http://logic.ti.com">logic.ti.com</a>
Power Mgmt	<a href="http://power.ti.com">power.ti.com</a>
Microcontrollers	<a href="http://microcontroller.ti.com">microcontroller.ti.com</a>
RFID	<a href="http://www.ti-rfid.com">www.ti-rfid.com</a>
OMAP Mobile Processors	<a href="http://www.ti.com/omap">www.ti.com/omap</a>
Wireless Connectivity	<a href="http://www.ti.com/wirelessconnectivity">www.ti.com/wirelessconnectivity</a>

### Applications

Communications and Telecom	<a href="http://www.ti.com/communications">www.ti.com/communications</a>
Computers and Peripherals	<a href="http://www.ti.com/computers">www.ti.com/computers</a>
Consumer Electronics	<a href="http://www.ti.com/consumer-apps">www.ti.com/consumer-apps</a>
Energy and Lighting	<a href="http://www.ti.com/energy">www.ti.com/energy</a>
Industrial	<a href="http://www.ti.com/industrial">www.ti.com/industrial</a>
Medical	<a href="http://www.ti.com/medical">www.ti.com/medical</a>
Security	<a href="http://www.ti.com/security">www.ti.com/security</a>
Space, Avionics and Defense	<a href="http://www.ti.com/space-avionics-defense">www.ti.com/space-avionics-defense</a>
Transportation and Automotive	<a href="http://www.ti.com/automotive">www.ti.com/automotive</a>
Video and Imaging	<a href="http://www.ti.com/video">www.ti.com/video</a>

TI E2E Community Home Page

[e2e.ti.com](http://e2e.ti.com)

Mailing Address: Texas Instruments, Post Office Box 655303, Dallas, Texas 75265  
Copyright © 2011, Texas Instruments Incorporated