

17" Fanless Multi-touch IP66 Full Waterproof Panel PC with Intel® Core™ i5/ Celeron® Processor



Features

- 17" SXGA LCD Panel with Projected Capacitive Touch
- Intel® Core™ i5-6200U/ Celeron® 3955U Processor
- Supports Two-finger Touch Control while Wearing Gloves Completely Flat Front Panel Design
- Stainless Steel Full IP66 Waterproof
- VESA Mounting

Applications

- Food & Beverage Processing
- Application Hospitality and Catering
- Service
- Pharmaceutical and Biopharmaceutical Equipment
- Animal Feed Production Facility

Packing List

Description
1 x GSR-Z177
1 x Driver CD

Optional Items

Part No.	Description
APW-60M12V-01	12V, 60W, 5A, 5-pin M12 Connector (US)
APW-60M12V-02	12V, 60W, 5A, 5-pin M12 Connector (EU)
AKT-USB2M12	M12 Connector to USB Cable, 2m
AKT-COM2M12	M12 Connector to DB9 Cable, 2m
AKT-VGA2M12	M12 Connector to DB15 Cable, 2m
AKT-LAN2M12	M12 Connector to LAN Cable, 2m
ACS-100-STD	VESA Table Stand

Ordering Information

Part No.	Description
GSR-Z177P-1A1	17" Fanless Projected Capacitive Touch Panel PC, Full IP66 Protection, Intel® Core™ i5 6200U Processor, 2 GbE LAN, 4 USB 2.0, 2 COM, M12 Connectors
GSR-Z177P-2A1	17" Fanless Projected Capacitive Touch Panel PC, Full IP66 Protection, Intel® Celeron® 3955U Processor, 2 GbE LAN, 4 USB 2.0, 2 COM, M12 Connectors

Dimensions

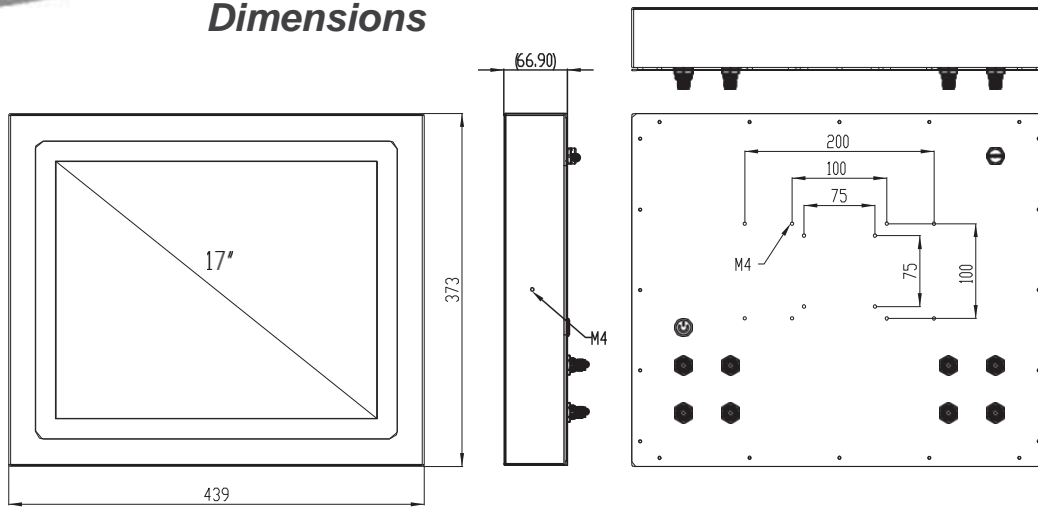

Specifications

Model		GSR-Z177P-1A1	GSR-Z177P-2A1
Processor System	CPU	Intel® Core™i5-6200U	Intel® Celeron® 3955U
	Frequency	Dual-Core up to 2.8 GHz	Dual-Core up to 2.0 GHz
	L2 Cache	3 MB	2 MB
	System Chipset	N/A	
Memory	BIOS	UEFI	
	Technology	DDR4 2133 MHz SDRAM	
	Max. Capacity	On Board 4 GB	
Display	Socket	N/A	
	Panel Size	17" LCD Panel	
	Resolution	1280 x 1024 (SXGA)	
	Viewing Angle	80 x 80 (H) x 60 x 80 (V)	
	Brightness	350 (cd/m2)	
	Color Support	16.7M	
	Contrast Ratio	800:1	
	Response Time	30 (msec)	
	VGA	Up to 1920 x 1200	
	Connector Type	M12	
Touchscreen	Dual Display	LCD + VGA	
	Touchscreen Type	Projected Capacitive	
	Surface Hardness	7	
	Durability	-	
I/O Interface	Transparency	90% (±3%)	
	USB	4 USB 2.0, M12 Connector	
	Serial Port	2 COM (1 RS-232, 1 RS-232/422/485), M12 Connector	
Ethernet	Expansion	1 Mini PCIe (Full-size), 2 M.2 Slot	
	Controller	Dual GbE, 10/100/1000 Mbps (Intel i211), M12 Connector	
Audio	Chipset	Realtek ALC269 High Definition Audio (HD)	
Storage	Connector	N/A	
	SATA II	1 Internal 2.5" HDD/SSD	
Power	Power Supply Voltage	12-28 V DC input	
	Connector Type	M12	
	Power Consumption (Typical)	2.38 A @ 12 V (28.56 W)	
	Power Consumption (Max.)	3.63 A @ 12 V (43.64 W)	
Environment	Battery	Lithium 3 V / 210 mAH	
	Operating Temperature	-20~60° C (-4~140° F) w/ 2.5" Extended Temperature SSD	
	Storage Temperature	-40~85° C (-40~185° F)	
	Humidity	5~95% @ 40° C, non-condensing	
	Vibration	5-500 Hz, 0.026 G ² /Hz, 2.16 Grms, X, Y, Z, 1 hour per axis	
General	Certification	CE, FCC Class A	
	Front Panel Waterproof	Full IP66, stainless steel	
	Dimensions (L x W x H)	439 x 373 x 66.9 mm (17.28" x 14.69" x 2.63")	
	Weight	7.77 kg (17.13 lb)	
	Operating System	Windows 7/8.1/10, WES7-E/P, WE8S, Ubuntu 14.04	