

Light is OSRAM



# LINEARLIGHT POWER FLEX LF06P2

TECHNICAL DATASHEET

## Key Features & Benefits

- High-intensity LED light source
- Linear separable LED strip on flexible printed circuit board with self-adhesive back
- High quality single PCB from continuous reel-to-reel production for improved reliability
- Current control technology for constant flux level along the module
- Fine white binning (3 steps MacAdam ellipse)
- PWM Dimmable



## Possible Applications

- Architectural lighting / integration  
Coves, hand rails, walls, edge coupling, et.al.
- Object lighting / integration
- Signage application

## QUICK REFERENCE

Product	Order Code	Color	K	V	W/m	lm/m	lm/W	Beam Angle (°)	Shipping Units
LF06P2-W5F-824	4052899942769	white	2400	24	18.2	1600	88	120	8
LF06P2-W5F-827	4008321971272	white	2700	24	22.7	1600	70	120	8
LF06P2-W5F-830	4008321971296	white	3000	24	22.7	1720	76	120	8
LF06P2-W5F-840	4008321971319	white	4000	24	22.7	1850	81	120	8
LF06P2-W5F-850	4008321971791	white	5000	24	22.7	1850	81	120	8
LF06P2-W5F-865	4008321971333	white	6500	24	22.7	1850	81	120	8

Due to the special conditions of manufacturing processes of LED, the typical data of technical parameters can only reflect statistical figures and do not necessarily correspond to the actual parameters of each single product which could differ from the typical data.

Subject to change without notice. Errors and omissions excepted.

Version: 2016-04-07

**TECHNICAL OPERATING DATA FOR COMPLETE REEL**

Product	Order Code	Power [W]	Current [A]	Luminous Flux [lm]	Module Length [m]
LF06P2-W5F-824	4052899942769	54.6	2.3	4,800	3
LF06P2-W5F-827	4008321971272	68.0	2.8	4,790	3
LF06P2-W5F-830	4008321971296	68.0	2.8	5,170	3
LF06P2-W5F-840	4008321971319	68.0	2.8	5,540	3
LF06P2-W5F-850	4008321971791	68.0	2.8	5,540	3
LF06P2-W5F-865	4008321971333	68.0	2.8	5,540	3

**Technical Specifications**

**GENERAL**

Dimmable	Pulse width modulation (PWM)
Binning	Fine white (3 step MacAdam ellipse)
Lifetime	50,000 h (L70B50, Tc max)
Adhesive tape on backside	3M F 9460
Complementary systems	CONNECTsystem, SLIMCONNECTsystem, SLIM TRACK, OPTOTRONIC
Certifications	CE, UL8750 recognized, UL2108 listed, ENEC, EAC, RoHS compliant

**OPERATING CONDITIONS**

Operating temperature at Tc-Point [°C]	-20 – 75
Storage temperature [°C]	-20 – 75
Voltage range [V dc]	23 – 25
Reverse Voltage [V dc]	25

- Exceeding maximum ratings for operating and storage temperature will reduce expected life time or destroy the LED Module.
- Exceeding maximum ratings for operating voltage will cause hazardous overload and will likely destroy the LED Module.
- The temperature of the LED module must be measured at the Tc-point according to EN60598-1 in a thermally constant status with a temperature sensor or a temperature sensitive label. For exact location of the Tc-point see drawing below.

**Technical Drawings**

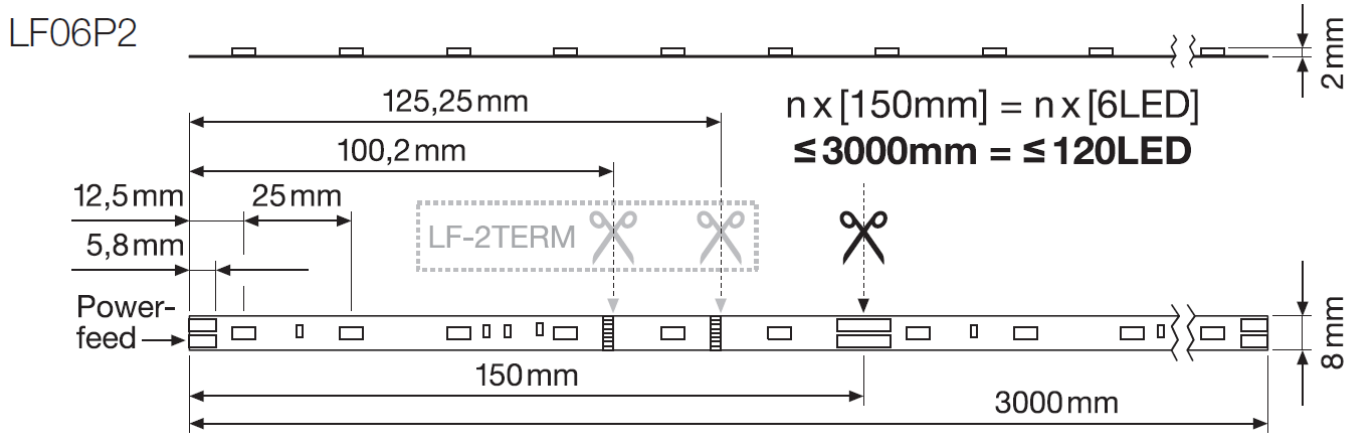

Due to the special conditions of manufacturing processes of LED, the typical data of technical parameters can only reflect statistical figures and do not necessarily correspond to the actual parameters of each single product which could differ from the typical data.

Subject to change without notice. Errors and omissions excepted.

Version: 2016-04-07

## Safety information

- The LED module itself and all its components must not be mechanically stressed.
- Assembly must not damage or destroy conducting paths on the circuit board.
- Installation of LED modules (with power supplies) needs to be made with regard to all applicable electrical and safety standards. Only qualified personnel should be allowed to perform installations.
- Observe correct polarity!  
Depending on the product incorrect polarity will lead to emission of red or no light. The module can be destroyed! Correct polarity immediately!
- Parallel connection is highly recommended as safe electrical operation mode. Serial connection is not recommended. Unbalanced voltage drop can cause hazardous overload and damage the LED module.
- Please ensure that the power supply is of adequate power to operate the total load.
- When mounting on metallic or otherwise conductive surfaces, there needs to be an electrical isolation at soldering points between module and the mounting surface.
- The maximum length of LF06P2 is 3m (68 W version) with power feed at one end.
- Pay attention to standard ESD precautions when installing the module.
- If the module is supposed to be cut at the earl-cutting-positions intended for the LF-2TERM respect the correct orientation of the module: The power feed must come from the side indicated in the technical drawing
- The module, as manufactured, has no conformal coating and therefore offers no inherent protection against corrosion. The ability to customize the length of the module by cutting at specifically marked points is a key feature of the product and hence the reason for no factory installed conformal coating. For these reasons, it is recommended that the user complete all module modifications first (cutting wiring) and then apply a conformal coating in the final stages of installation.
- Damage by corrosion will not be honored as a materials defect claim. It is the user's responsibility to provide suitable protection again corrosive agents such as moisture and condensation and other harmful elements.
- For applications involving exposure to humidity and dust the module must be protected by a fixture or housing with a suitable protection class. The module can be protected against condensation water by treatment with an appropriate circuit board grade conformal coating. The conformal coating should have the following features:
  - Optical transparency
  - UV-resistance
  - Thermal expansion matching the thermal expansion of the module
  - Low permeability of steam for all climatic conditions
  - Resistance against corrosive environment.

In order to drive OSRAM LED-Modules safely, it is absolutely necessary to operate them with an electronically stabilized power supply protecting against short circuits, overload and overheating. To also ease the luminaire/installation approval, electronic control gear for LED or LED modules should carry the CE mark and be ENEC certified. In Europe the declarations of conformity must include the following standards: CE: EC 61347-2-13, EN 55015, IEC 61547 and IEC 61000-3-2 - ENEC: 61347-2-13 and IEC/EN 62384. Also check for the mark of an independent authorized certification institute. Please see the relevant brochure for more detailed information (see "Related and Further Information") OSRAM OPTOTRONIC® control gear complies with all relevant standards and guarantees safe operation.

## Assembly Information

- Connection with soldering wires on unmounted module:  
Do not pre-tin the solder-pads but pre-tin the wires and solder for max 4s at 300°C.  
Allow solder-points to completely cool down before the next soldering.  
Prevent shear- or peel forces.
- Soldering of wires with the module mounted on a heatsink:  
Pre-tin solder-pads and wires and solder for max 3 s at 350 °C.  
Allow solder-points to completely cool down before the next soldering.  
Prevent shear- or peel forces.
- The smallest unit (150 mm – 6 LEDs) can be removed by cutting with scissors between the designated solder pads.
- Mounting of the module is facilitated by the double-sided adhesive tape on the back-surface of the module.

Due to the special conditions of manufacturing processes of LED, the typical data of technical parameters can only reflect statistical figures and do not necessarily correspond to the actual parameters of each single product which could differ from the typical data.

Subject to change without notice. Errors and omissions excepted.

Version: 2016-04-07

- Mounting surface must be clean and dry, free of oils or silicone coatings as well as dirt particle.
- The mounting substrate must have sufficient structural integrity. Take care to completely remove the protective backing. Once the module is appropriately positioned, pre on the module with about 20N/cm<sup>2</sup> (refer to application techniques of 3M adhesive transfer tapes). In difficult cases the use of a prime may help.
- Maximum temperature ratings must be kept. Therefore the module must be mounted on a metal heat sink
- The minimum bending radius is 2 cm. The module may be bent over a smaller radius but only in regions of the circuit board containing electronic components and such bends should be made once and fixed in position to avoid cyclic fatigue.
- Bending is only allowed within the bending axis of the PCB. Bending outside of that leads to torsion which may cause damage to the module and will lead to failure.
- When installing in environments with large variations in temperature (e.g. outdoor applications) and operating length of more than 2 m, the use of adequate mounting surfaces is necessary. Otherwise it is advisable to use an additional thicker adhesive tape to absorb the stress of any mismatch in expansion.

## Complementary Systems & Accessories

### SLIMCONNECT SYSTEM

Description	Product name	Order Code	Shipping details
2pin Feeder	LF-2PIN Flex SC	4008321832436	10 / 250
Jumper (board-to-board)	LF-CONN Flex SC	4008321832467	25 / 250
Extension wire 30mm	LF-WIRE-30 FLEX SC	4008321875587	100 / 10,000
Extension wire 150mm	LF-WIRE-150 FLEX SC	4008321875563	50 / 5,000

### CONNECT SYSTEM

Description	Product name	Order Code	Shipping details
2pin Feeder	LF-2PIN FLEX	4008321955326	10 / 100
Jumper (10mm extension)	LF-CONN-10 FLEX	4008321955333	10 / 200
Jumper (150mm extension)	LF-CONN-150 FLEX	4008321955340	10 / 100
Termination unit for early-cutting-marks	LF-2TERM FLEX	4008321955357	10 / 200

### SLIMTRACK SYSTEM

Description	Product name	Order Code	Shipping details
SLIM TRACK	LF-LTS-2100 SLIM TRACK	4008321978981	40
Mounting Bracket for SLIM TRACK	LF-LTS-MB	4008321979025	35 / 280
Clear SLIM TRACK Cover	LF-LTS COVER C	4008321790187	40
Diffuse SLIM TRACK Cover	LF-LTS-COVER-DIFFUSE	4008321979001	40
Endcap for Diffuse Cover	LF-LTS-ENDCAP	4008321979049	20 / 160
Semi-Diffuse SLIM TRACK Cover	LF-LTS COVER S	4008321790200	40

Due to the special conditions of manufacturing processes of LED, the typical data of technical parameters can only reflect statistical figures and do not necessarily correspond to the actual parameters of each single product which could differ from the typical data.

Subject to change without notice. Errors and omissions excepted.

Version: 2016-04-07

**OPTOTRONIC**

Recommended OPTOTRONIC® drivers	EAN
<b>Non-dimmable</b>	
OPTOTRONIC OT 6/200-240/24 CE	4008321113269
OPTOTRONIC OT 8/200-240/24	4008321040169
OPTOTRONIC OT 20/220-240/24	4050300618111
OPTOTRONIC OT 20/120-240/24 S	4050300662626
OPTOTRONIC OT 75/220-240/24	4050300817477
OPTOTRONIC OT 75/220-240/24 E	4008321362476
OPTOTRONIC OT 80/220-240/24 P	4008321981684
OPTOTRONIC OT 120/220-240/24 P	4008321981707
OPTOTRONIC OT 240/220-240/24 P	4008321981721
<b>Dimmable</b>	
OPTOTRONIC OT EASY 60 II	4008321187796
OPTOTRONIC OT EASY 80	4008321808363
OPTOTRONIC OT 65/220-240/24 3DIM E	4008321964403
OPTOTRONIC OTi DALI 75/220-240/24 1-4 CH	4008321371560
OPTOTRONIC OT 80/220-240/24 DIM P	4008321981677
OPTOTRONIC OT 120/220-240/24 DIM P	4008321981691
OPTOTRONIC OT 240/220-240/24 DIM P	4008321981714

Please consider that lengths may differ if further controls are installed.

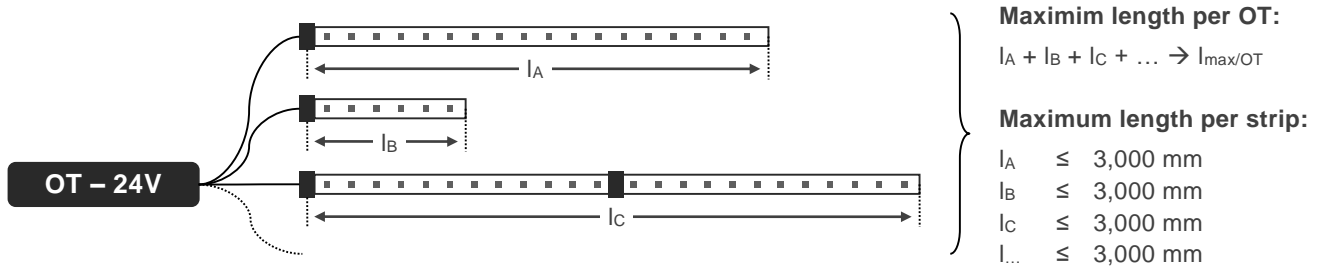

**Global order information**

EUROPE/MEA		US/CA	
LF06P2-W5F-824	4052899942769		
LF06P2-W5F-827	4008321971272	L68LFE/24V/827/PF	71329
LF06P2-W5F-830	4008321971296	L68LFE/24V/830/PF	71328
LF06P2-W5F-840	4008321971319	L68LFE/24V/840/PF	71327
LF06P2-W5F-850	4008321971791		
LF06P2-W5F-865	4008321971333		

Due to the special conditions of manufacturing processes of LED, the typical data of technical parameters can only reflect statistical figures and do not necessarily correspond to the actual parameters of each single product which could differ from the typical data. Subject to change without notice. Errors and omissions excepted.  
 Version: 2016-04-07

## Light is OSRAM

# OSRAM

LINEARLIGHT POWER FLEX  
LF06P2  
TECHNICAL DATASHEET  
2016-04-07

## Related and further information

- OSRAM LED Systems [www.osram.com/led-systems](http://www.osram.com/led-systems)
- OSRAM: FLEXIBLE LED MODULES [www.osram.com/flex](http://www.osram.com/flex)
- OSRAM catalogue <http://catalog.osram.com>
- General information [www.osram.com](http://www.osram.com)



### OSRAM GmbH

Head Office:

Marcel-Breuer-Strasse 6  
80807 Munich, Germany

+49 89 6213-0  
[www.osram.com](http://www.osram.com)

Sales and technical support is given by the local OSRAM subsidiaries.

On the OSRAM website all subsidiaries are listed with complete address and phone numbers.

# OSRAM