

规格书编号

SPEC NO :

产品规格书

SPECIFICATION

CUSTOMER 客户: _____
PRODUCT 产品: _____ SAW FILTER _____
MODEL NO 型号: _____ HDF387A SMD-4 _____
MARKING 印字: _____ HDF4341 _____
PREPARED 编制: _____ CHECKED 审核: _____
APPROVED 批准: _____ D A T E 日期: _____ 2010-12-13 _____

客户确认 CUSTOMER RECEIVED:		
审核 CHECKED	批准 APPROVED	日期 DATE

无锡市好达电子有限公司
Shoulder Electronics Limited

1. ELECTRICAL SPECIFICATION

DC Voltage VDC	10V
AC Voltage Vpp	10V50Hz/60Hz
Operation temperature	-45°C to +85°C
Storage temperature	-45°C to +85°C
RF Power Dissipation	0dBm

Electronic Characteristics

1-1. Typical frequency response

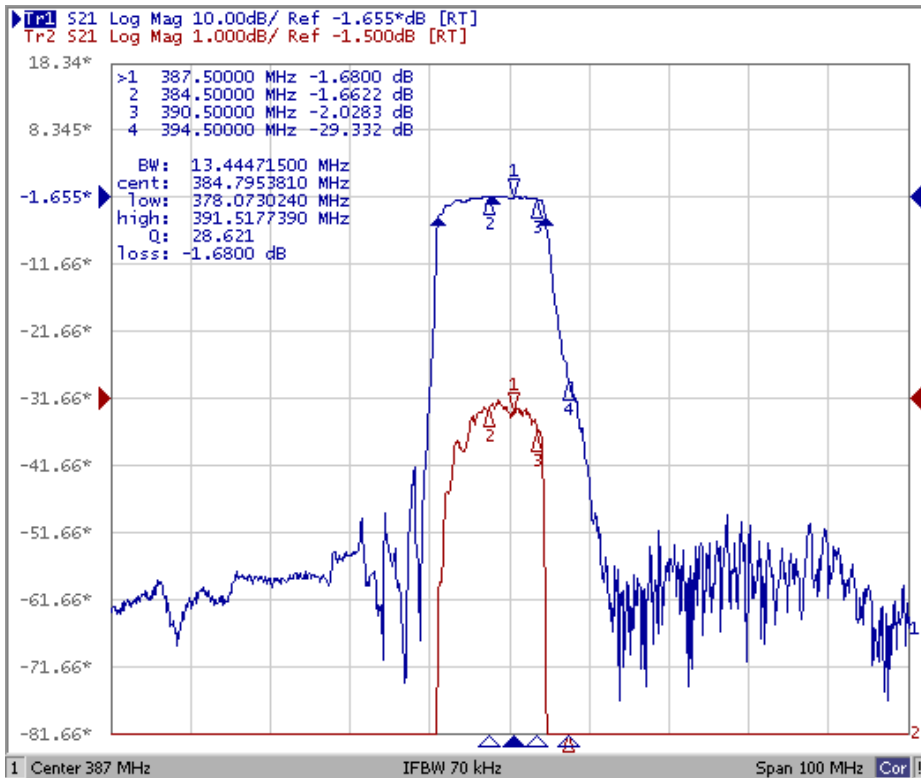

1-2. Electrical characteristics

	Unit	Minimum	Typical	Maximum
Center Frequency	MHz	-	387.5	-
Insertion Loss (384.5~390.5 MHz)	dB		2.0	3.5
Amplitude Ripple (384.5~390.5 MHz)	dB		1.0	1.5
VSWR (384.5~390.5 MHz)	dB		1.5	2.0
Relative Attenuation				
10 ~341 MHz		40	60	
394.5~400.5 MHz	dB	20	22	-
410~920 MHz		40	50	
920~1220 MHz		40	50	
Input/Output Impedance	Ohms		50	

2. TEST CIRCUIT

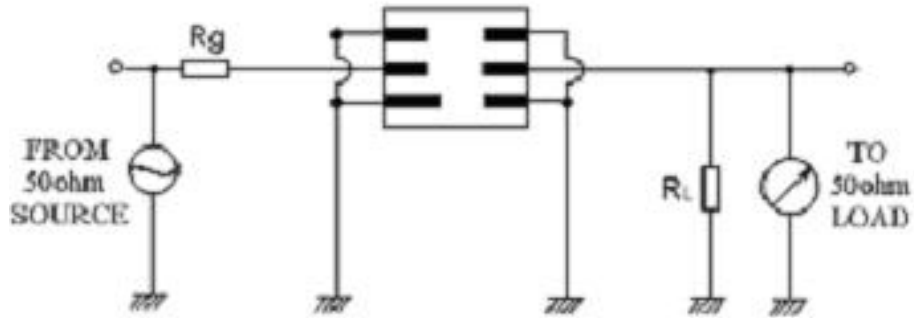

3. DIMENSION

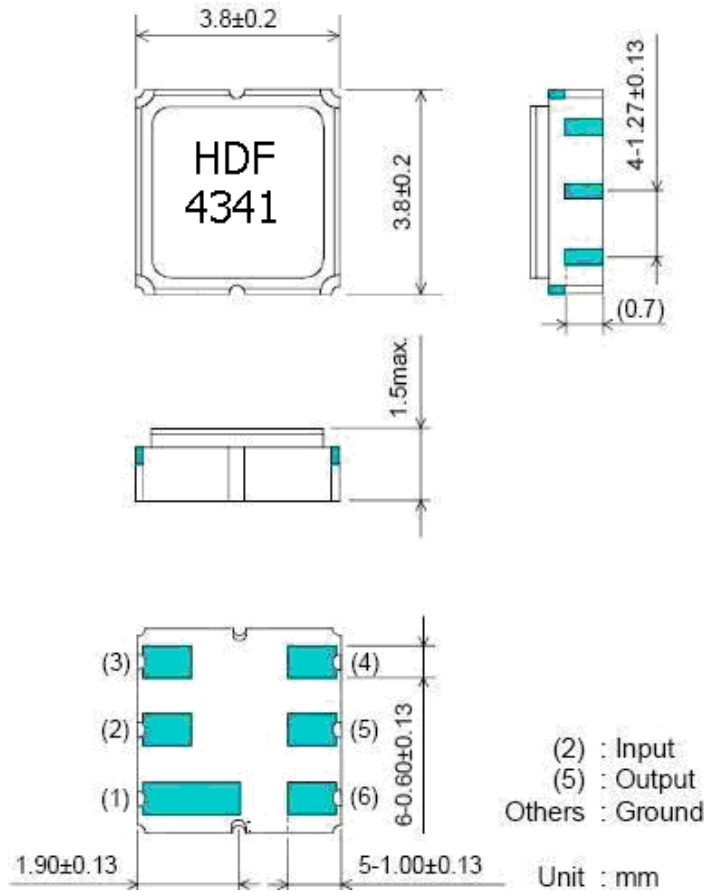

Marking: HDF

- HD: Brand
- F : Filter
- 4 : SMD-4
- 341: No.

5. ENVIRONMENTAL CHARACTERISTICS

5-1 High temperature exposure

Subject the device to +85°C for 16 hours. Then release the filter into the room conditions for 24 hours prior to the measurement. It shall fulfill the specifications in table 1.

5-2 Low temperature exposure

Subject the device to -20°C for 16 hours. Then release the device into the room conditions for 24 hours prior to the measurement. It shall fulfill the specifications in table 1.

5-3 Temperature cycling

Subject the device to a low temperature of -40°C for 30 minutes. Following by a high temperature of +80°C for 30 Minutes. Then release the device into the room conditions for 24 hours prior to the measurement. It shall meet the specifications in table 1.

5-4 Resistance to solder heat

Dip the device terminals no closer than 1.5mm into the solder bath at 260°C \pm 10°C for 10 \pm 1 sec. Then release the device into the room conditions for 4 hours. The device shall meet the specifications in table 1.

5-5 Solderability

Subject the device terminals into the solder bath at 245°C \pm 5°C for 5s, More than 95% area of the terminals must be covered with new solder. It shall meet the specifications in table 1.

5-6 Mechanical shock

Drop the device randomly onto the concrete floor from the height of 1m 3 times. the device shall fulfill the specifications in table 1.

5-7 Vibration

Subject the device to the vibration for 1 hour each in x,y and z axes with the amplitude of 1.5 mm at 10 to 55 Hz. The device shall fulfill the specifications in table 1.

5-8 Lead fatigue

5-8-1 Pulling test

Weight along with the direction of lead without an shock 1kg. The device shall satisfy all the initial Characteristics.

5-8-2 Bending test

Lead shall be subject to withstand against 90°C bending with 450g weight in the direction of thickness. This operation shall be done toward both direction. The device shall show no evidence of damage and shall satisfy all the initial electrical characteristics.

6. REMARK

6.1 Static voltage

Static voltage between signal load & ground may cause deterioration & destruction of the component. Please avoid static voltage.

6.2 Ultrasonic cleaning

Ultrasonic vibration may cause deterioration & destruction of the component. Please avoid ultrasonic cleaning

6.3 Soldering

Only leads of component may be soldered. Please avoid soldering another part of component.

7. Packing

7.1 Dimensions

(1) Carrier Tape: Figure 1

(2) Reel: Figure 2

(3) The product shall be packed properly not to be damaged during transportation and storage.

7.2 Reeling Quantity

1000 pcs/reel 7"

3000 pcs/reel 13"

7.3 Taping Structure

(1) The tape shall be wound around the reel in the direction shown below.

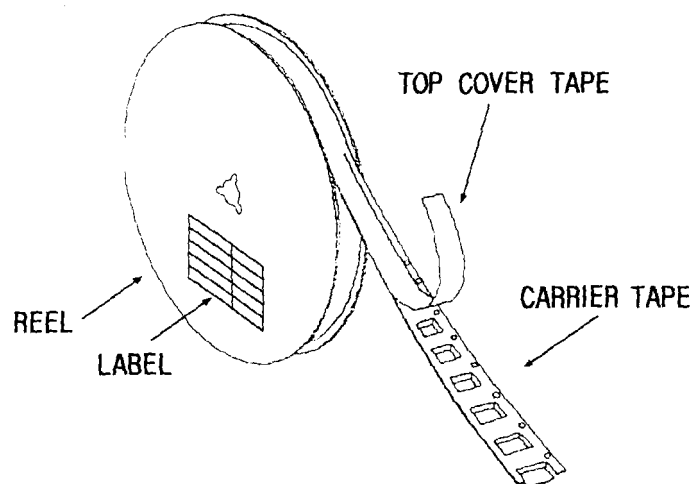

(2) Label

Device Name	
User Product Name	
Quantity	
Lot No.	

(3) Leader part and vacant position specifications.

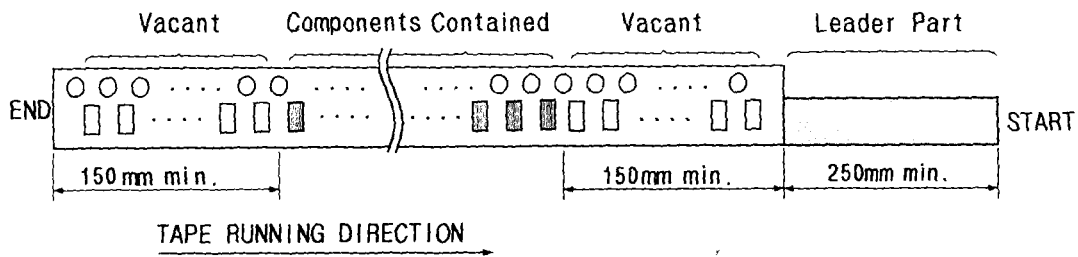

8. TAPE SPECIFICATIONS

8.1 Tensile Strength of Carrier Tape: 4.4N/mm width

8.2 Top Cover Tape Adhesion (See the below figure)

- (1) pull off angle: 0~15°
- (2) speed: 300mm/min.
- (3) force: 20~70g

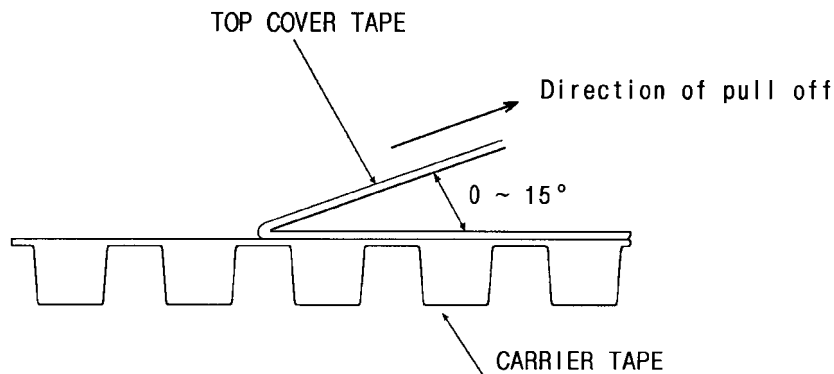

[Figure 1] Carrier Tape Dimensions

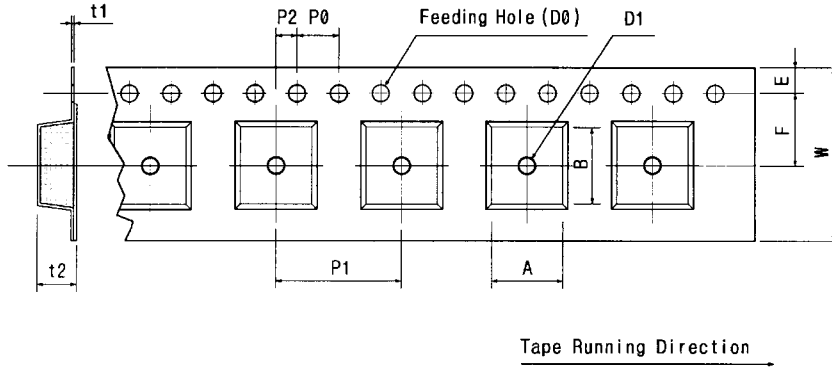

[Unit:mm]

W	F	E	P0	P1	P2	D0	D1	t1	t2	A	B
12.00	5.50	1.75	4.00	8.00	2.00	Ø1.50	Ø1.0	0.25	1.65	4.04	4.10
±0.30	±0.10	±0.10	±0.10	±0.10	±0.10		±0.25	±0.05	±0.10	±0.10	±0.10

[Figure 2]

[Unit:mm]

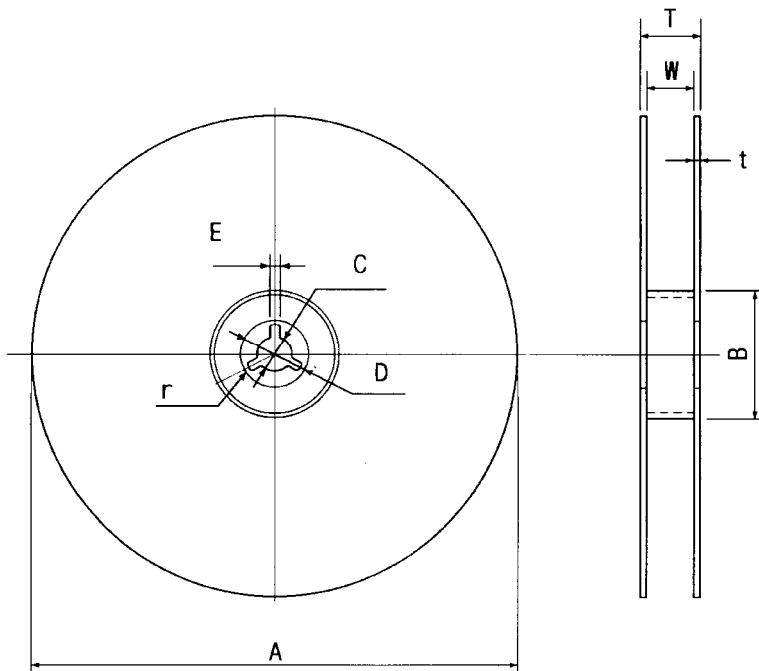

A	B	C	D	E	W	t	r
Ø330	Ø100	Ø13	Ø21	2	13	3	1.0
±1.0	±0.5	±0.5	±0.8	±0.5	±0.3	max.	max.