

PSD1-A-xxxxE



PSD-SERIES

Rev.01-2016

- ✓ 1 Watt
- ✓ Unregulated ***Ready for UL****
- ✓ **Single Output**
- ✓ **SMD Case**
- ✓ **1.5 kV - 3 kV DC I/O Isolation**
- ✓ **Continuous Short Circuit Prot.**
- ✓ **2 Years Warranty (Date Code)**

The PSD1-A series is a family of cost effective 1 W single output DC/DC converters. These converters are in an ultra miniature SMD 5-pin case. Devices are encapsulated. High performance features: 1500VDC and 3000VDC (for the most types) input/output isolation, industrial standard pinout, high power density. No heatsink required.

*most 1.5kV devices are ready for UL. Please ask for MOQ if you need Certification.

All specifications typical at Ta=25°C, nominal input voltage and full load unless otherwise specified

Input Specifications

Voltage Range	±10%
Current max.	52 – 404mA (See table)
Current No-Load	7 – 25mA (See table)
Filter	Capacitors
Reflected Ripple Current (@12uH)	15mA pk-pk

General Specifications

Efficiency	Up to 80% (See table)
Isolation I/O (60 sec)	1500VDC (standard) 3000VDC (add "H30")
Isolation I/O Capacitance	20 pF
Isolation I/O Resistance	1000 MΩ, min.
Switching Frequency	100 kHz
Humidity (rel.)	95%
MTBF (Calculated MIL-HDBK-217F)	>3500 Khrs
Pin Welding Temperature	300°C, max.
Reflow Soldering	245°C, peak (217°C ≤60s)

EMC Specifications

Radiated Emissions*	CISPR22/EN55022	Class B
Conducted Emissions*	CISPR22/EN55022	Class B
ESD (contact ±8KV)	IEC-61000-4-2	Pref. Criteria B

*Input filter components are required to meet (see App Note)

Output Specifications

Voltage accuracy	See App Note
Line regulation (per 1% Vin change)	±1.2% (1.5% for 3.3Vout)
Load regulation (10% to 100%)	See Table
Ripple & noise (20 MHz bandwidth)	60 mV pk-pk
Temperature coefficient	±0.03%/°C
Capacitor load (Test: min. Vin + const. load)	220uF
Short Circuit Protection	Continuous (exceptions see Table)

Environment / Physical Specifications

Operation Temp.	-40°C to 105°C
Case Temp. Rise (nominal Input and full load)	25°C
Storage	-55°C to 125°C
Cooling	Nature / Free Air
Case Material	Plastic (UL94V-0 rated)
Potting	Epoxy (UL94V-0 rated)
Weight	~1.6 g

Selection Guide

Single Output

Order #	Input Voltage (VDC)	Output Voltage (VDC)	Output Current max. (mA)	Output Current min. (mA)	Input Current Full Load typ. (mA)	Input Current no Load typ. (mA)	Load Regulation (%)	Efficiency (%)
SINGLE OUTPUT								
PSD1-A-3R33R3E	3.3	3.3	303	30	404	25	18	69
PSD1-A-3R305E	3.3	5	200	20	404	25	12	74
PSD1-A-3R312E	3.3	12	84	9	404	25	7	80
PSD1-A-3R315E	3.3	15	67	7	404	25	6	80
PSD1-A-3R324E	3.3	24	42	4	404	25	5	80
PSD1-A-053R3E	5	3.3	303	30	250	20	18	72
PSD1-A-0505E	5	5	200	20	250	20	12	80
PSD1-A-0506E	5	6	167	17	250	20	10	80
PSD1-A-0509E	5	9	111	12	250	20	8	80
PSD1-A-0512E	5	12	84	9	250	20	7	80
PSD1-A-0515E	5	15	67	7	250	20	6	80
PSD1-A-0524E*	5	24	42	4	250	20	5	80
PSD1-A-123R3E	12	3.3	303	30	104	15	18	72
PSD1-A-1205E	12	5	200	20	104	15	12	80
PSD1-A-1209E	12	9	111	12	104	15	8	80
PSD1-A-1212E	12	12	84	9	104	15	7	80
PSD1-A-1215E	12	15	67	7	104	15	6	80
PSD1-A-1224E	12	24	42	4	104	15	5	80
PSD1-A-1505E	15	5	200	20	82	10	12	80
PSD1-A-1515E	15	15	67	7	82	10	6	80
PSD1-A-2405E*	24	5	200	20	52	7	12	80
PSD1-A-2409E*	24	9	111	12	52	7	8	80
PSD1-A-2412E*	24	12	84	9	52	7	7	80
PSD1-A-2415E*	24	15	67	7	52	7	6	80
PSD1-A-2424E*	24	24	42	4	52	7	5	80

* Converters marked with a star: Short circuit Protection ist only 1s, max

* Supply voltage must be discontinued at the end of short circuit.

If you need other specifications, please enquire.

For optional 3000V isolation, please add “H30”
For example: PSD1-A-1205EH30

Notes:

Package / Pinning / Derating

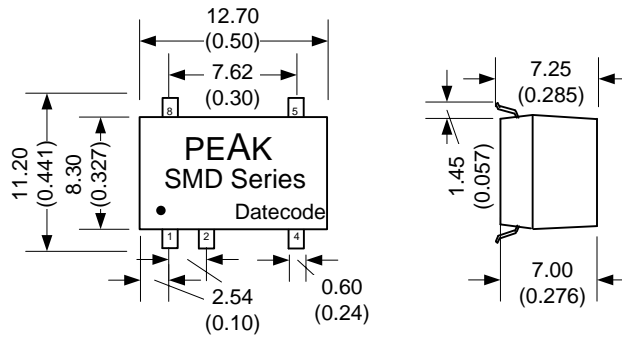

All dimensions are typical in millimeters (inches).
 - Pin pitch tolerance: ± 0.35 (± 0.014)
 - Case tolerance ± 0.7 (± 0.028)
 Specification may change without notice.

PSD1-Series
Single output

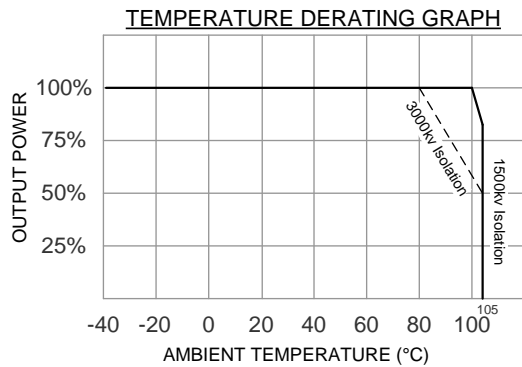

PIN CONNECTIONS	
#	SINGLE
1	- Vin
2	+Vin
4	- Vout
5	+Vout
8	N.C.

App Notes

EMC Typical Recommended Circuit (CLASS B)

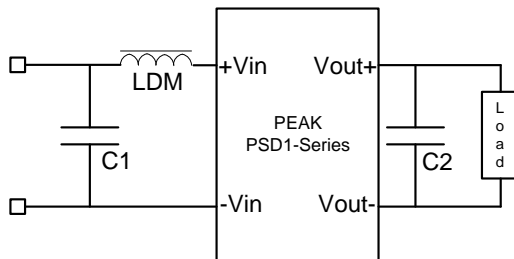

Vout	C1	C2	LDM
3.3	4.7uF/50V	10 uF	6.8uH
5 / 6	4.7uF/50V	10 uF	6.8uH
9	4.7uF/50V	4.7 uF	6.8uH
12	4.7uF/50V	2.2 uF	6.8uH
15	4.7uF/50V	1 uF	6.8uH
24	4.7uF/50V	0.47 uF	6.8uH

Tolerance Envelope Curve

5, 6, 9, 12, 15, 24 Vout:

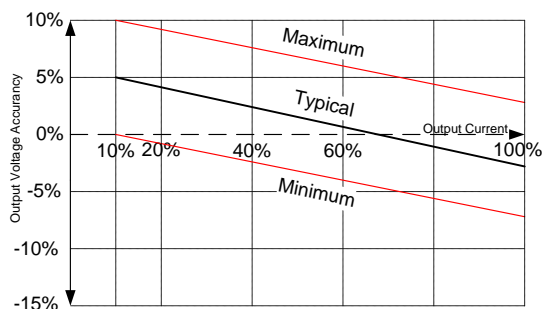

3.3 Vout:

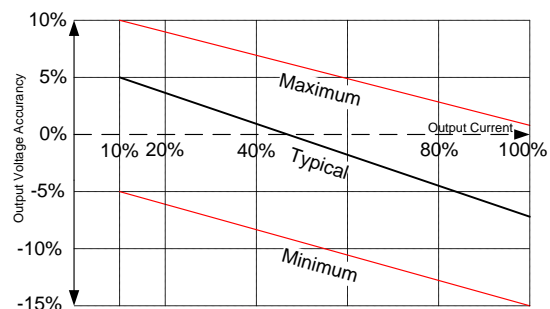

Requirement on output load

This module can operate efficiently and reliably if the minimum output load is **not less than 10%** of the full load. If the actual output power is very small, please connect a resistor with proper resistance at the output end in parallel to increase the load.

It is recommended to connect ceramic capacitor or electrolytic capacitor at the input and output of the DCDC converter.

It is not recommended to increase the output power capability by connecting two or more converters in parallel. The product is not hot-swappable.

No parallel connection or plug and play.