

APPROVAL SHEET

AMBLN Series – 1005(0402) - RoHS Compliance

MULTILAYER CERAMIC BALUN TRANSFORMER

Halogens Free Product

LTE B40/B41 Band RF Application

Automotive

Qualified to AEC-Q200

P/N: AMBLN10052G5WM9T16

*Contents in this sheet are subject to change without prior notice.

FEATURES

1. Miniature footprint: 1.0 X 0.5 X 0.4 mm³
2. Low Insertion Loss
3. Low in-band amplitude and phase imbalance enhances system performance
4. LTCC process

APPLICATIONS

1. LTE B40/B41 band RF applications

CONSTRUCTION

Top view

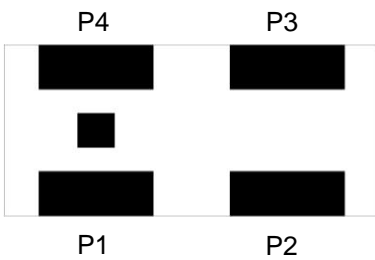

PIN	Connection	PIN	Connection
1	Unbalanced port	3	Balanced port
2	GND	4	Balanced port

DIMENSIONS

Figure	Symbol	Dimension (mm)
Top view	L	1.00 ± 0.10
	W	0.50 ± 0.10
Bottom view	T	0.37 ± 0.10
	A	0.10 ± 0.10
Side view	B	0.30 ± 0.10
	C	0.20 ± 0.10
	D	0.50 ± 0.10
	E	0.125 ± 0.10

ELECTRICAL CHARACTERISTICS

AMBLN10052G5WM9T16	Specification
Frequency range	2300 ~ 2690 MHz
Insertion Loss	0.65 dB max. at +25°C 0.95 dB max. at -55°C ~ +125°C
Phase Difference	180° ± 10°
Amplitude Difference	2.5 dB max.
VSWR	2.0 max.
Unbalanced Impedance	50 Ω
Balanced Impedance	100 Ω
Moisture sensitivity levels	LEVEL 1 (Refer to: IPC/JEDEC J-STD-020)

Operating & Storage Condition (Component)

Operation Temperature Range: -55°C ~ +125°C
Storage Temperature Range: -55°C ~ +125°C

Storage Condition before Soldering (Included packaging material)

Storage Temperature Range: +5 ~ +40°C
Humidity: 30 to 70% relative humidity

Typical Electrical Chart

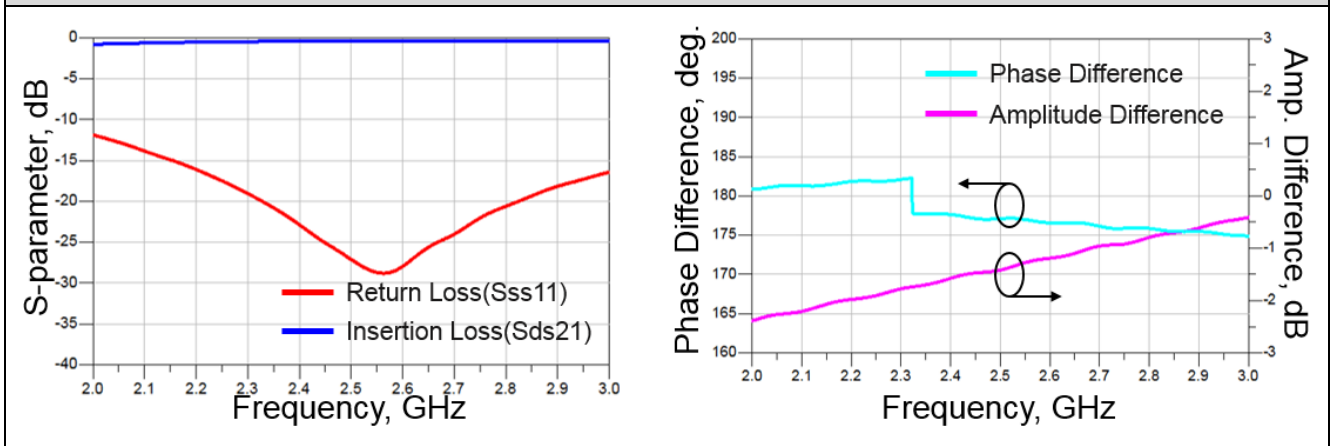

LAND PATTERN

Figure

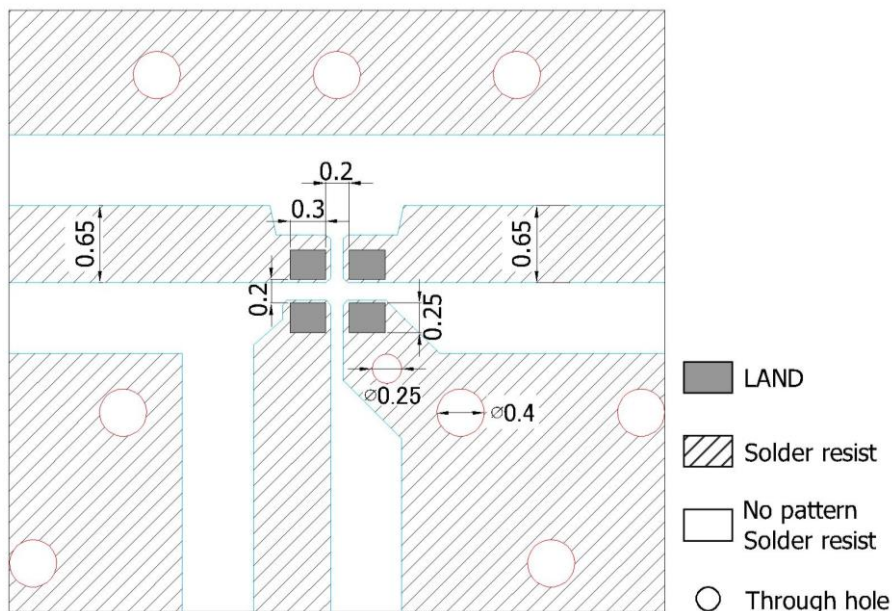

Unit: mm

Line width to be designed to match 50 Ω characteristic impedance, depending on PCB material and thickness.

RELIABILITY TEST

TEST	PROCEDURE / TEST METHOD	REQUIREMENT
Resistance to soldering heat (R.S.H) MIL-STD-202 method 210	Un-mounted chips completely immersed for 10 ± 1 second in a SAC solder bath at $270^\circ\text{C} \pm 5^\circ\text{C}$	No mechanical damage. Electrical specification shall satisfy the descriptions in electrical characteristics under the operational temperature range within $-55 \sim 125^\circ\text{C}$. Loss of metallization on the edges of each electrode shall not exceed 25
Solderability J-STD-002	* Condition A Un-mounted chips 4hrs / 155°C *dry then completely immersed for 5 ± 0.5 sec in solder bath at $235 \pm 5^\circ\text{C}$. * Condition B Un-mounted chips steam 8 hrs then completely immersed for 10 ± 1 sec. in solder bath at $260 \pm 0 / -5^\circ\text{C}$.	All terminations shall exhibit a continuous solder coating free from defects from a minimum of 95% of the critical surface area of any individual termination.
Temperature cycling JESD22 method JA-104	1000 cycles, $-55^\circ\text{C} \sim +125^\circ\text{C}$, dwell time 30min	No mechanical damage. Electrical specification shall satisfy the descriptions in electrical characteristics under the operational temperature range within $-55 \sim 125^\circ\text{C}$.
Humidity MIL-STD-202 method 103	1000+48/-0 hours; 85°C , 85% RH	No mechanical damage. Electrical specification shall satisfy the descriptions in electrical characteristics under the operational temperature range within $-55 \sim 125^\circ\text{C}$.
High Temperature Exposure MIL-STD-202 method 108	1000+48/-0 hours; without load in a temperature chamber controlled $125 \pm 3^\circ\text{C}$	No mechanical damage. Electrical specification shall satisfy the descriptions in electrical characteristics under the operational temperature range within $-55 \sim 125^\circ\text{C}$.
Mechanical Shock MIL-STD-202 method 213	1/2 Sine Pulse / 100g Peak / Velocity 12.3ft/sec	No mechanical damage. Electrical specification shall satisfy the descriptions in electrical characteristics under the operational temperature range within $-55 \sim 125^\circ\text{C}$.
Board Flex AEC-Q200-005	RF component mounted on a 90mm glass epoxy resin PCB(FR4), bending once 2mm for 60sec	No mechanical damage. Electrical specification shall satisfy the descriptions in electrical characteristics under the operational temperature range within $-55 \sim 125^\circ\text{C}$.
Terminal strength AEC-Q200-006	Pressurizing force: 1.8Kg, Test time: 60 ± 1 sec. Only 0402 for 1.0kg/60sec	No remarkable damage or removal of the terminations
Vibration MIL-STD-202 method 204	Test 5g's for 20min., 12 cycles each of 3 orientations	No mechanical damage. Electrical specification shall satisfy the descriptions in electrical characteristics under the operational temperature range within $-55 \sim 125^\circ\text{C}$.
ESD AEC-Q200-002	Test contact 1.0KV (0.5KV for 1005 only)	No mechanical damage. Electrical specification shall satisfy the descriptions in electrical characteristics under the operational temperature range within $-55 \sim 125^\circ\text{C}$.

SOLDERING CONDITION

Typical examples of soldering processes that provide reliable joints without any damage are given in Fig 2,

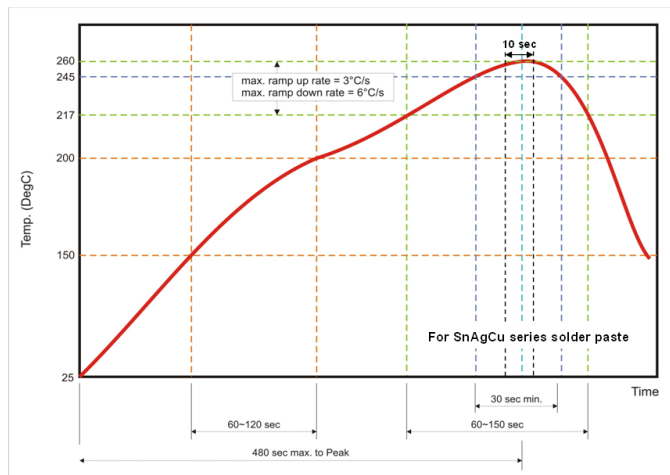

Fig 2. Infrared soldering profile

ORDERING CODE

AM	BLN	1005	2G5	W	M9T16
Walsin Automotive device	Product Code BLN: BALUN	Dimension code Per 2 digits of Length, Width, e.g.: 1005= Length 10, Width 05,	Central Frequency 2G5: 2.5GHz	Application W: Wi-Max	Specification Design Code

Minimum Ordering Quantity: 4000 pcs per reel.

PACKAGING

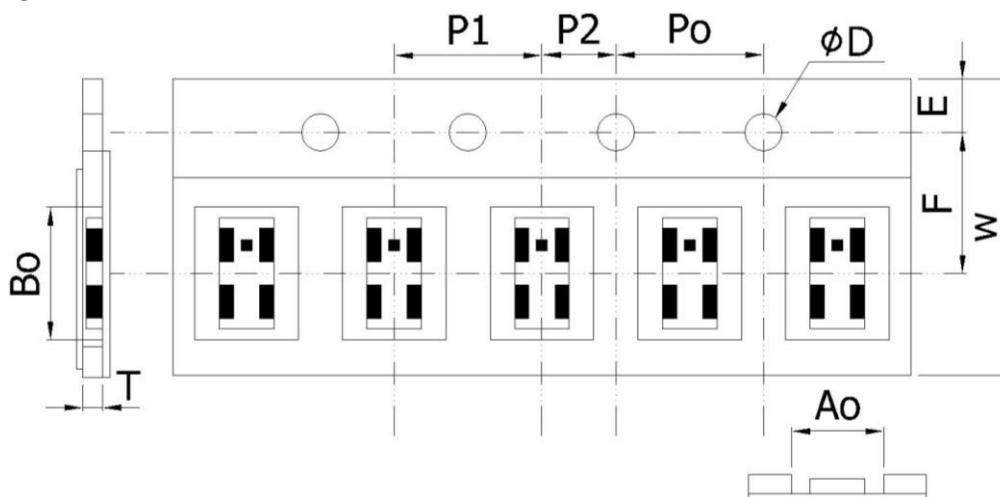

Paper Tape specifications (unit: mm)

Index	Ao	Bo	øD	T	W
Dimension (mm)	0.67 ± 0.10	1.14 ± 0.10	1.50 + 0.10	0.42 ± 0.10	8.0 ± 0.30
Index	E	F	Po	P1	P2
Dimension (mm)	1.75 ± 0.10	3.50 ± 0.20	4.00 ± 0.10	2.00 ± 0.10	2.00 ± 0.10

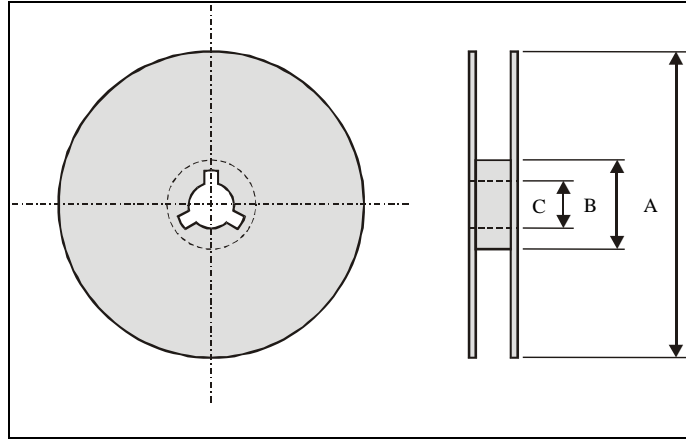
Reel dimensions

Index	A	B	C
Dimension (mm)	Φ178.0	Φ60.0	Φ13.0

Taping Quantity: 4000 pieces per 7" reel

CAUTION OF HANDLING**Limitation of Applications**

Please contact us before using our products for the applications listed below which require especially high reliability for the prevention of defects, which might directly cause damage to the third party's life, body or property.

- (1) Aircraft equipment
- (2) Aerospace equipment
- (3) Undersea equipment
- (4) Medical equipment
- (5) Disaster prevention / crime prevention equipment
- (6) Traffic signal equipment
- (7) Transportation equipment (vehicles, trains, ships, etc.)
- (8) Applications of similar complexity and /or reliability requirements to the applications listed in the above.

Storage condition

- (1) Products should be used in 6 months from the day of WALSIN outgoing inspection.
- (2) Storage environment condition.
 - Products should be storage in the warehouse on the following conditions.
 - Temperature : +5 to +40°C
 - Humidity : 30 to 70% relative humidity
 - Don't keep products in corrosive gases such as sulfur. Chlorine gas or acid or it may cause oxidization of electrode, resulting in poor solderability.
 - Products should be storage on the palette for the prevention of the influence from humidity, dust and son on.
 - Products should be storage in the warehouse without heat shock, vibration, direct sunlight and so on.
 - Products should be storage under the airtight packaged condition.