

NOTES:

1. MATERIALS AND FINISHES:
 BODY, REAR BODY -BRASS, NICKEL PLATING
 CONTACT - BRASS, GOLD PLATING
 INSULATOR - PTFE
 COUPLING NUT- BRASS, NICKEL PLATING
 CAP- BRASS, NICKEL PLATING
 FERRULE- COPPER, NICKEL PLATING

2. ELECTRICAL:
 A. IMPEDANCE: 50 OHM
 B. FREQUENCY RANGE: DC - 6 GHz
 C. VSWR(RETURN LOSS): -23 dB MAX

3. MECHANICAL:
 A. DURABILITY: 500 CYCLES MIN.
 B. TEMPERATURE RANGE: -65 C TO +165 C

4. PACKAGING:
 A. QUANTITY: SINGLE PACK
 B. MARKING: BAG TO BE MARKED
 "AMPHENOLRF, 82-6489 AND DATE CODE"

5. RECOMMENDED CABLE ASSEMBLY INSTRUCTIONS:
 A. TRIM CABLE AS SHOWN.
 B. SLIDE FERRULE AND REAR INSULATOR ONTO CABLE.
 C. INSERT CABLE WITH FOIL ENTERING CONNECTOR AND BRAID OVER KNURL.
 D. SOLDER CABLE CENTER CONDUCTOR TO CONTACT.
 E. CRIMP FERRULE OVER BRAID WITH 0.429" HEX DIE.

6. CAP ASSEMBLY INSTRUCTIONS:
 A. PLACE O-RING ON CAP AS SHOWN.
 B. ASSEMBLE CAP TO BODY WITH 6-10 IN-LBS TORQUE.

7. RECOMMENDED COUPLING TORQUE : 6-10 IN-LBS.

8.  SHOWS CABLE ENTRY DIMENSIONS.

THIRD ANGLE PROJ. 

REVISIONS

REV	DESCRIPTION	DATE	ECO	APPR
A	RELEASE TO MFG	4/26/12	49027	DD

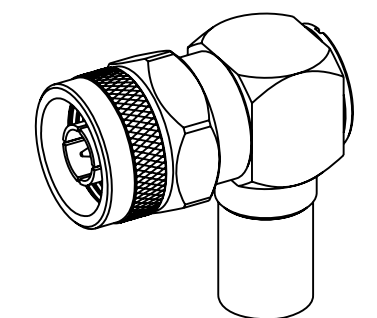
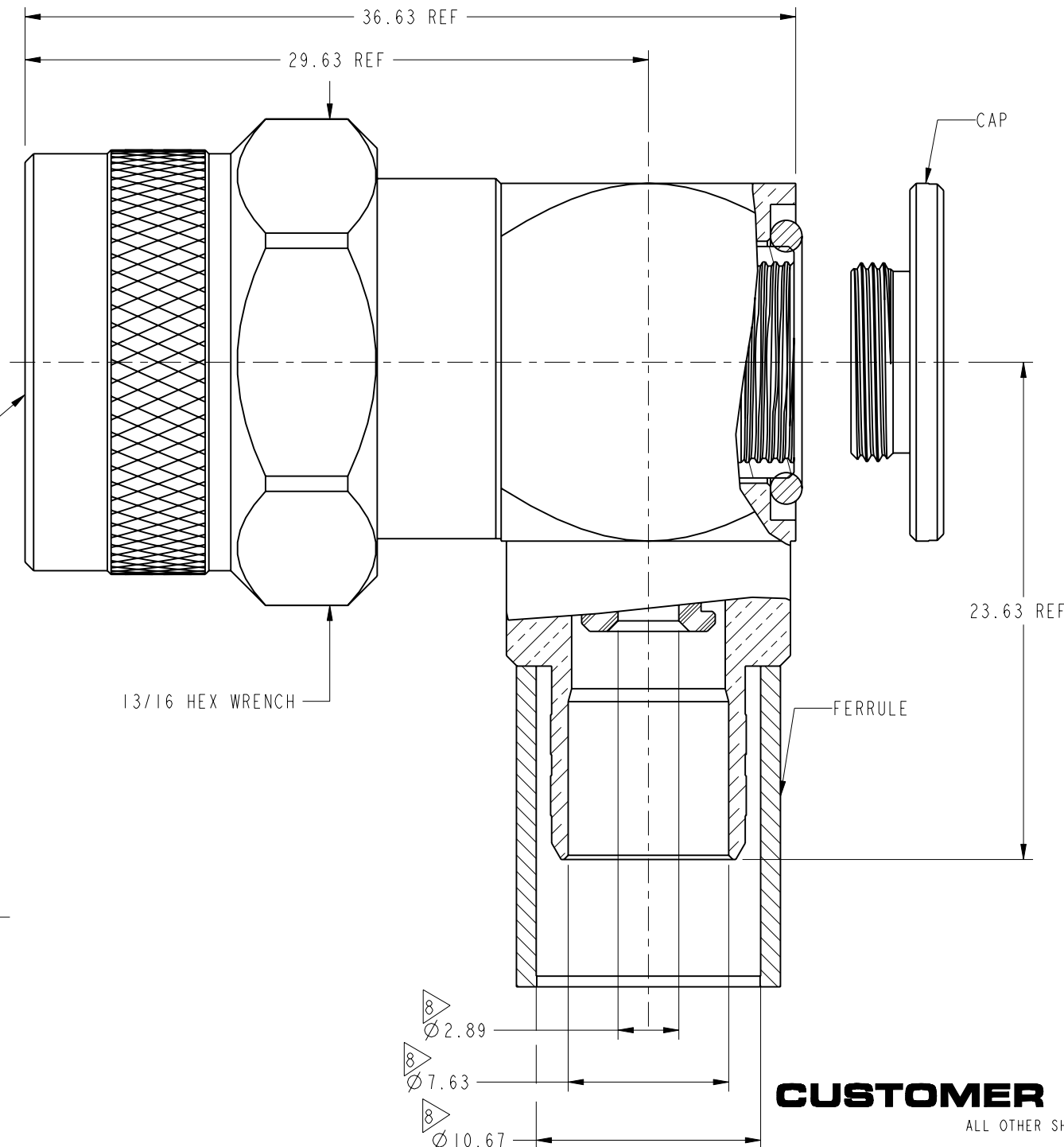

SCALE 1.000

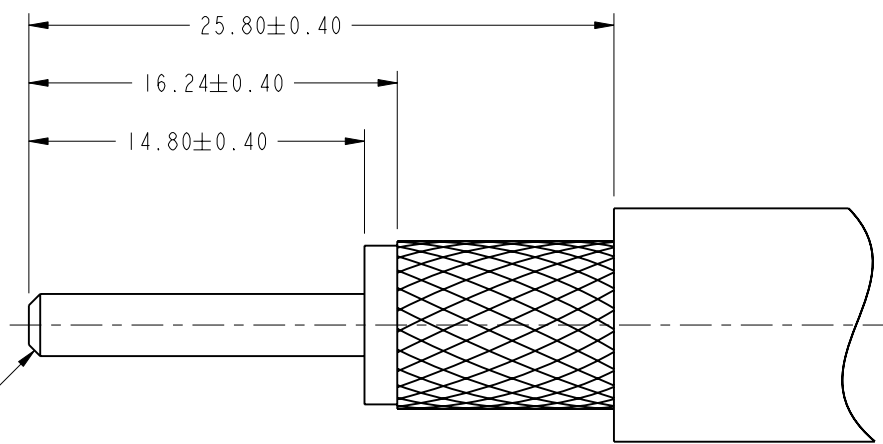

RECOMMENDED CABLE STRIPPING DIMENSIONS

CUSTOMER OUTLINE DRAWING

ALL OTHER SHEETS ARE FOR INTERNAL USE ONLY

UNLESS OTHERWISE SPECIFIED, DIMENSIONS ARE IN METRIC AND TOLERANCES ARE: <0.5mm ±0.05mm 0.5 - 6mm ±0.1mm 6 - 30mm ±0.2mm 30 - 120mm ±0.3mm ANGLES ±1°	MATERIAL	DRAWN	DATE	TITLE N PLUG R/A IP-67 FOR LMR-400-CABLE		Amphenol RF Danbury CT USA, Tainan, Taiwan, Shenzhen, China www.amphenolrf.com
	SEE NOTES	S.L.I	17-Jul-12			
NOTICE - These drawings, specifications, or other data (1) are, and remain the property of Amphenol corp. (2) must be returned upon request; and (3) are confidential and not to be disclosed to any person other than those to whom they are given by Amphenol Corp. the furnishing of these drawings, specifications, or other data by Amphenol Corp., or to any other person to anyone for any purpose is not to be regarded by implication or otherwise in any manner licensing, granting rights to permitting such holder or any other person to manufacture, use or sell any product, process or design, patented or otherwise, that may in any way be related to or disclosed by said drawings, specifications, or other data.	REFERENCE	ENGINEER	DATE	SCALE: 3.5:1.0		DRAWING NO.82-6489 ITEM NO.82-6489 PART NO.82-6489
	EAR # 4180	KARTHIK R	28-Mar-12	SHEET 2 OF 2		
	CONFIGURATION LEVEL: <input type="checkbox"/> <input type="checkbox"/>	APPROVED	DATE	REV		
FINISH		D.HU	31-Jul-12	A		
		CAD FILE		DWG SIZE		
		Root Folder/N/82-6489		B		