

# TPIC5403 4-CHANNEL INDEPENDENT GATE-PROTECTED POWER DMOS ARRAY

SLIS038A – SEPTEMBER 1994 – REVISED SEPTEMBER 1995

- Low  $r_{DS(on)}$  . . . 0.23  $\Omega$  Typ
- High Voltage Output . . . 60 V
- Extended ESD Capability . . . 4000 V
- Pulsed Current . . . 11.25 A Per Channel
- Fast Commutation Speed

## description

The TPIC5403 is a monolithic gate-protected power DMOS array that consists of four independent electrically isolated N-channel enhancement-mode DMOS transistors. Each transistor features integrated high-current zener diodes ( $Z_{CXa}$  and  $Z_{CXb}$ ) to prevent gate damage in the event that an overstress condition occurs. These zener diodes also provide up to 4000 V of ESD protection when tested using the human-body model of a 100-pF capacitor in series with a 1.5-k $\Omega$  resistor.

The TPIC5403 is offered in a 24-pin wide-body surface-mount (DW) package and is characterized for operation over the case temperature range of  $-40^{\circ}\text{C}$  to  $125^{\circ}\text{C}$ .

DW PACKAGE  
(TOP VIEW)

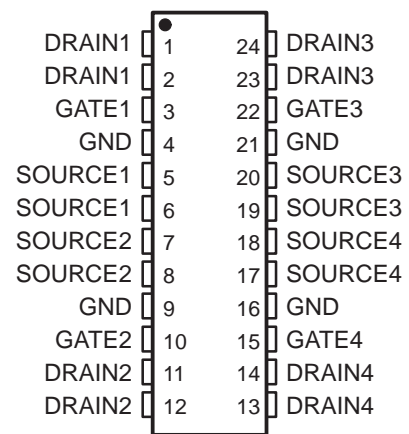

## schematic

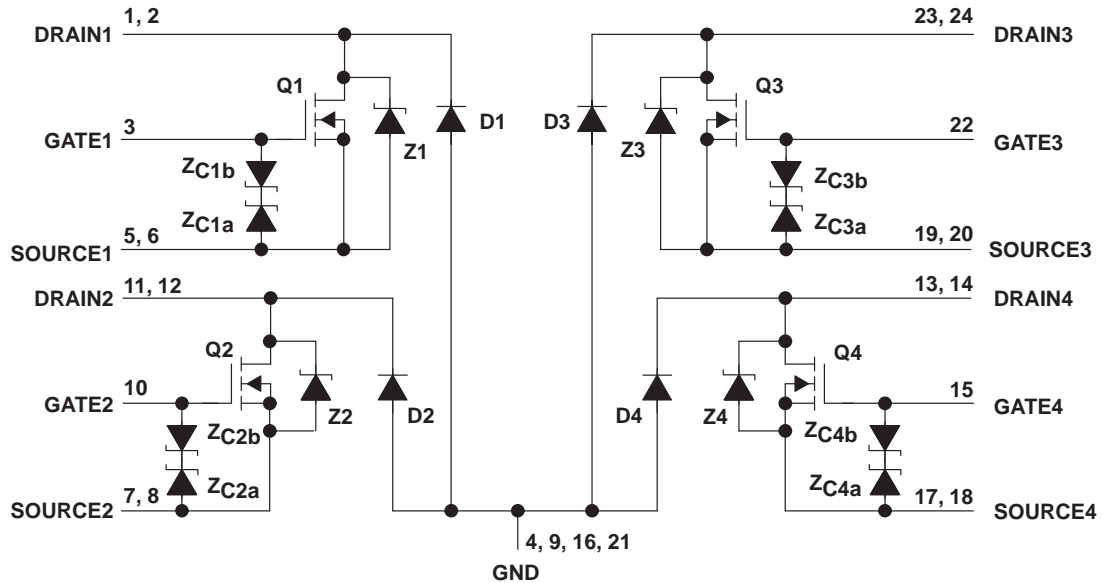

NOTE A: For correct operation, no terminal may be taken below GND.

# TPIC5403

## 4-CHANNEL INDEPENDENT GATE-PROTECTED POWER DMOS ARRAY

SLIS038A – SEPTEMBER 1994 – REVISED SEPTEMBER 1995

### absolute maximum ratings over operating case temperature range (unless otherwise noted)†

Drain-to-source voltage, $V_{DS}$	60 V
Source-to-GND voltage	100 V
Drain-to-GND voltage	100 V
Gate-to-source voltage range, $V_{GS}$	-9 V to 18 V
Continuous drain current, each output, $T_C = 25^\circ\text{C}$	2.25 A
Continuous source-to-drain diode current, $T_C = 25^\circ\text{C}$	2.25 A
Pulsed drain current, each output, $I_{max}$ , $T_C = 25^\circ\text{C}$ (see Note 1 and Figure 15)	11.25 A
Continuous gate-to-source zener diode current, $T_C = 25^\circ\text{C}$	$\pm 50$ mA
Pulsed gate-to-source zener diode current, $T_C = 25^\circ\text{C}$	$\pm 500$ mA
Single-pulse avalanche energy, $E_{AS}$ , $T_C = 25^\circ\text{C}$ (see Figures 4, 15, and 16)	17.2 mJ
Continuous total power dissipation, $T_C = 25^\circ\text{C}$ (see Figure 15)	1.39 W
Operating virtual junction temperature range, $T_J$	$-40^\circ\text{C}$ to $150^\circ\text{C}$
Operating case temperature range, $T_C$	$-40^\circ\text{C}$ to $125^\circ\text{C}$
Storage temperature range, $T_{stg}$	$-65^\circ\text{C}$ to $150^\circ\text{C}$
Lead temperature 1,6 mm (1/16 inch) from case for 10 seconds	$260^\circ\text{C}$

† Stresses beyond those listed under “absolute maximum ratings” may cause permanent damage to the device. These are stress ratings only, and functional operation of the device at these or any other conditions beyond those indicated under “recommended operating conditions” is not implied. Exposure to absolute-maximum-rated conditions for extended periods may affect device reliability.

NOTE 1: Pulse duration = 10 ms, duty cycle = 2%



**TPIC5403**  
**4-CHANNEL INDEPENDENT GATE-PROTECTED**  
**POWER DMOS ARRAY**

SLIS038A – SEPTEMBER 1994 – REVISED SEPTEMBER 1995

**electrical characteristics,  $T_C = 25^\circ\text{C}$  (unless otherwise noted)**

PARAMETER		TEST CONDITIONS		MIN	TYP	MAX	UNIT
$V_{(BR)DSX}$	Drain-to-source breakdown voltage	$I_D = 250\ \mu\text{A}$ ,	$V_{GS} = 0$	60			V
$V_{GS(th)}$	Gate-to-source threshold voltage	$I_D = 1\ \text{mA}$ , See Figure 5	$V_{DS} = V_{GS}$	1.5	1.75	2.2	V
$V_{(BR)GS}$	Gate-to-source breakdown voltage	$I_{GS} = 250\ \mu\text{A}$		18			V
$V_{(BR)SG}$	Source-to-gate breakdown voltage	$I_{SG} = 250\ \mu\text{A}$		9			V
$V_{(BR)}$	Reverse drain-to-GND breakdown voltage (across D1, D2, D3, and D4)	Drain-to-GND current = $250\ \mu\text{A}$		100			V
$V_{DS(on)}$	Drain-to-source on-state voltage	$I_D = 2.25\ \text{A}$ , See Notes 2 and 3	$V_{GS} = 10\ \text{V}$ ,		0.5	0.62	V
$V_{F(SD)}$	Forward on-state voltage, source-to-drain	$I_S = 2.25\ \text{A}$ , $V_{GS} = 0$ (Z1, Z2, Z3, Z4), See Notes 2 and 3 and Figure 12			0.9	1.1	V
$V_F$	Forward on-state voltage, GND-to-drain	$I_D = 2.25\ \text{A}$ (D1, D2, D3, D4), See Notes 2 and 3			2.5		V
$I_{DSS}$	Zero-gate-voltage drain current	$V_{DS} = 48\ \text{V}$ , $V_{GS} = 0$	$T_C = 25^\circ\text{C}$	0.05	1		$\mu\text{A}$
			$T_C = 125^\circ\text{C}$	0.5	10		
$I_{GSSF}$	Forward gate current, drain short circuited to source	$V_{GS} = 15\ \text{V}$ ,	$V_{DS} = 0$		20	200	nA
$I_{GSSR}$	Reverse gate current, drain short circuited to source	$V_{SG} = 5\ \text{V}$ ,	$V_{DS} = 0$		10	100	nA
$I_{lkg}$	Leakage current, drain-to-GND	$V_{DGND} = 48\ \text{V}$	$T_C = 25^\circ\text{C}$	0.05	1		$\mu\text{A}$
			$T_C = 125^\circ\text{C}$	0.5	10		
$r_{DS(on)}$	Static drain-to-source on-state resistance	$V_{GS} = 10\ \text{V}$ , $I_D = 2.25\ \text{A}$ , See Notes 2 and 3 and Figures 6 and 7	$T_C = 25^\circ\text{C}$	0.23	0.27		$\Omega$
			$T_C = 125^\circ\text{C}$	0.35	0.4		
$g_{fs}$	Forward transconductance	$V_{DS} = 15\ \text{V}$ , See Notes 2 and 3 and Figure 9	$I_D = 1.125\ \text{A}$ ,	1.6	2.1		S
$C_{iss}$	Short-circuit input capacitance, common source				200	250	pF
$C_{oss}$	Short-circuit output capacitance, common source	$V_{DS} = 25\ \text{V}$ , $f = 1\ \text{MHz}$ ,	$V_{GS} = 0$ , See Figure 11		100	175	
$C_{rss}$	Short-circuit reverse-transfer capacitance, common source				60	75	

- NOTES: 2. Technique should limit  $T_J - T_C$  to  $10^\circ\text{C}$  maximum.  
3. These parameters are measured with voltage-sensing contacts separate from the current-carrying contacts.

**source-to-drain and GND-to-drain diode characteristics,  $T_C = 25^\circ\text{C}$**

PARAMETER		TEST CONDITIONS		MIN	TYP	MAX	UNIT
$t_{rr}$	Reverse-recovery time	$I_S = 1.125\ \text{A}$ , $V_{GS} = 0$ , See Figures 1 and 14	$V_{DS} = 48\ \text{V}$ , $di/dt = 100\ \text{A}/\mu\text{s}$ ,	Z1, Z2, Z3, and Z4	80		ns
				D1, D2, D3, and D4	160		
$Q_{RR}$	Total diode charge			Z1, Z2, Z3, and Z4	0.12		$\mu\text{C}$
				D1, D2, D3, and D4	0.5		



**TPIC5403**  
**4-CHANNEL INDEPENDENT GATE-PROTECTED**  
**POWER DMOS ARRAY**

SLIS038A – SEPTEMBER 1994 – REVISED SEPTEMBER 1995

**resistive-load switching characteristics,  $T_C = 25^\circ\text{C}$**

PARAMETER	TEST CONDITIONS	MIN	TYP	MAX	UNIT
$t_{d(on)}$ Turn-on delay time	$V_{DD} = 25\text{ V}$ , $R_L = 20\ \Omega$ , $t_{r1} = 10\text{ ns}$ , See Figure 2		32	55	ns
$t_{d(off)}$ Turn-off delay time			27	50	
$t_{r2}$ Rise time			14	30	
$t_{f2}$ Fall time			7	15	
$Q_g$ Total gate charge	$V_{DS} = 48\text{ V}$ , $I_D = 1.125\text{ A}$ , $V_{GS} = 10\text{ V}$ , See Figure 3		6.6	8	nC
$Q_{gs(th)}$ Threshold gate-to-source charge			0.6	0.7	
$Q_{gd}$ Gate-to-drain charge			2.8	3.2	
$L_D$ Internal drain inductance			5		nH
$L_S$ Internal source inductance			5		
$R_g$ Internal gate resistance			0.25		$\Omega$

**thermal resistance**

PARAMETER	TEST CONDITIONS	MIN	TYP	MAX	UNIT
$R_{\theta JA}$ Junction-to-ambient thermal resistance	See Notes 4 and 7		90		$^\circ\text{C/W}$
$R_{\theta JB}$ Junction-to-board thermal resistance	See Notes 5 and 7		49		$^\circ\text{C/W}$
$R_{\theta JP}$ Junction-to-pin thermal resistance	See Notes 6 and 7		28		$^\circ\text{C/W}$

- NOTES: 4. Package mounted on an FR4 printed-circuit board with no heatsink  
5. Package mounted on a 24 inch<sup>2</sup>, 4-layer FR4 printed-circuit board  
6. Package mounted in intimate contact with infinite heatsink  
7. All outputs with equal power

**PARAMETER MEASUREMENT INFORMATION**

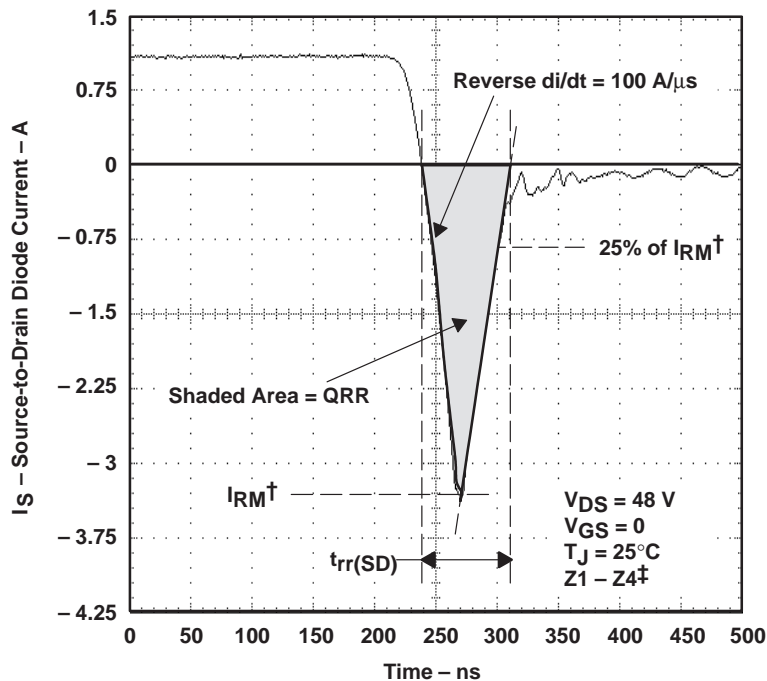

$^\dagger I_{RM}$  = maximum recovery current

$\ddagger$  The above waveform is representative of D1, D2, D3, and D4 in shape only.

**Figure 1. Reverse-Recovery-Current Waveform of Source-to-Drain Diode**

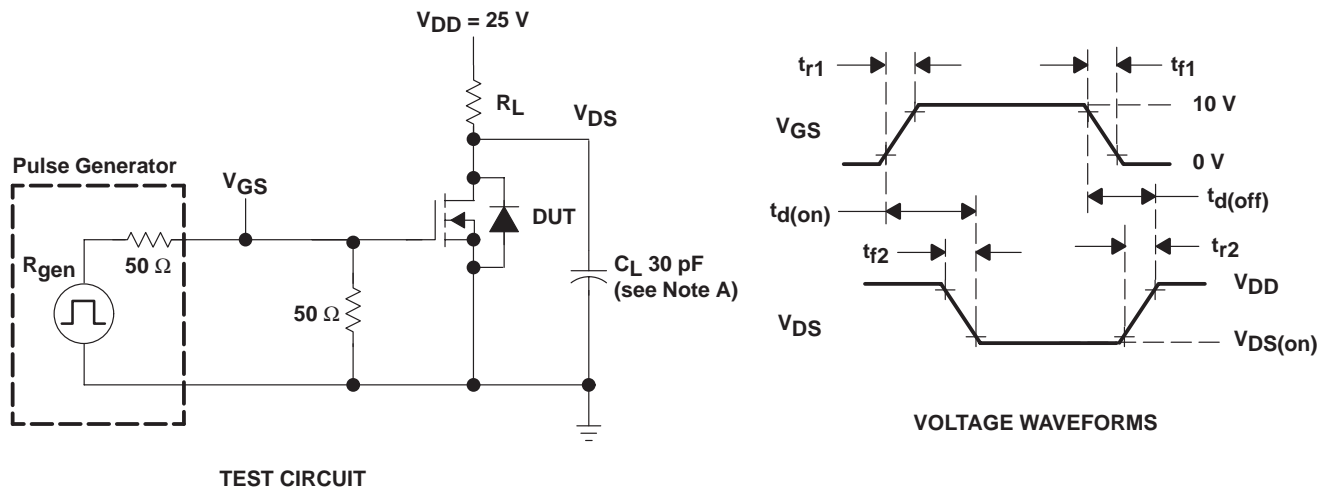

**TEST CIRCUIT**

NOTE A:  $C_L$  includes probe and jig capacitance.

**Figure 2. Resistive-Switching Test Circuit and Voltage Waveforms**

**TPIC5403**  
**4-CHANNEL INDEPENDENT GATE-PROTECTED**  
**POWER DMOS ARRAY**

SLIS038A – SEPTEMBER 1994 – REVISED SEPTEMBER 1995

**PARAMETER MEASUREMENT INFORMATION**

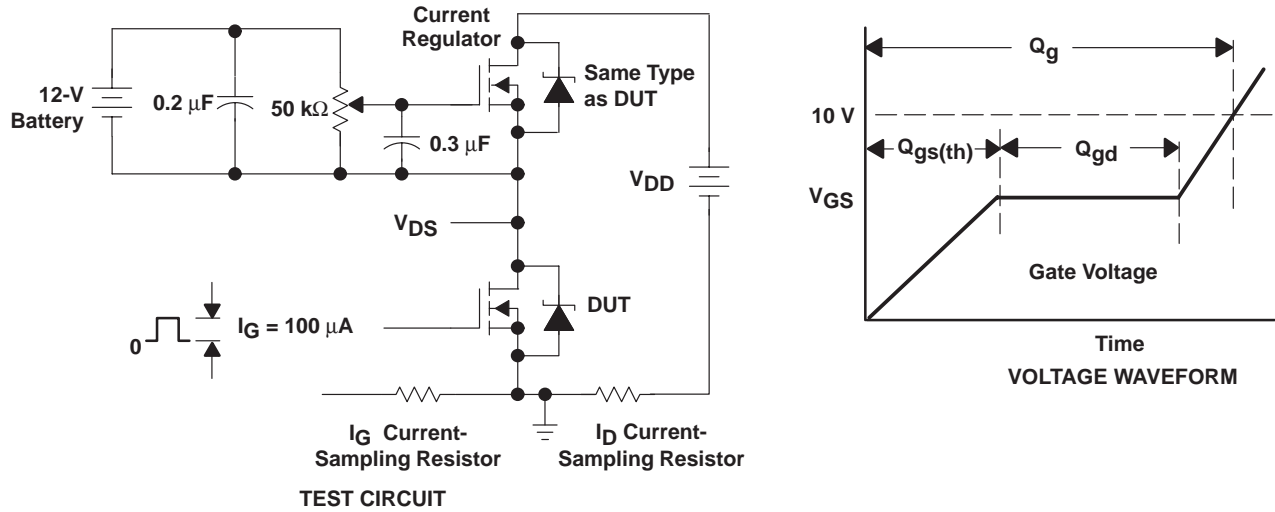

**Figure 3. Gate-Charge Test Circuit and Voltage Waveform**

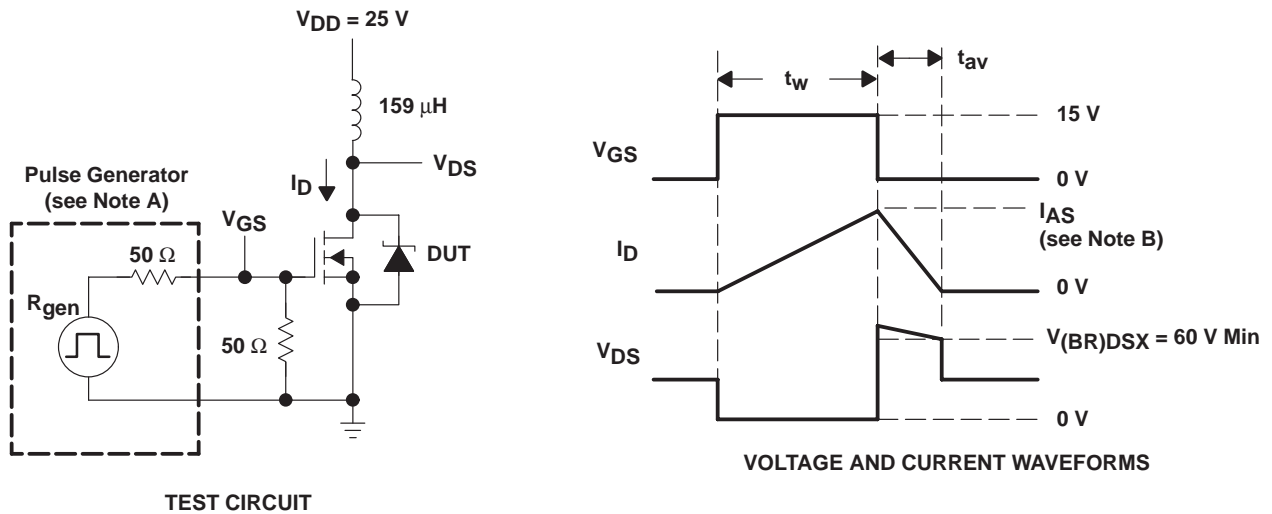

NOTES: A. The pulse generator has the following characteristics:  $t_r \leq 10$  ns,  $t_f \leq 10$  ns,  $Z_0 = 50 \Omega$ .

B. Input pulse duration ( $t_w$ ) is increased until peak current  $I_{AS} = 11.25$  A.

$$\text{Energy test level is defined as } E_{AS} = \frac{I_{AS} \times V_{(BR)DSX} \times t_{av}}{2} = 17.2 \text{ mJ.}$$

**Figure 4. Single-Pulse Avalanche-Energy Test Circuit and Waveforms**

TYPICAL CHARACTERISTICS

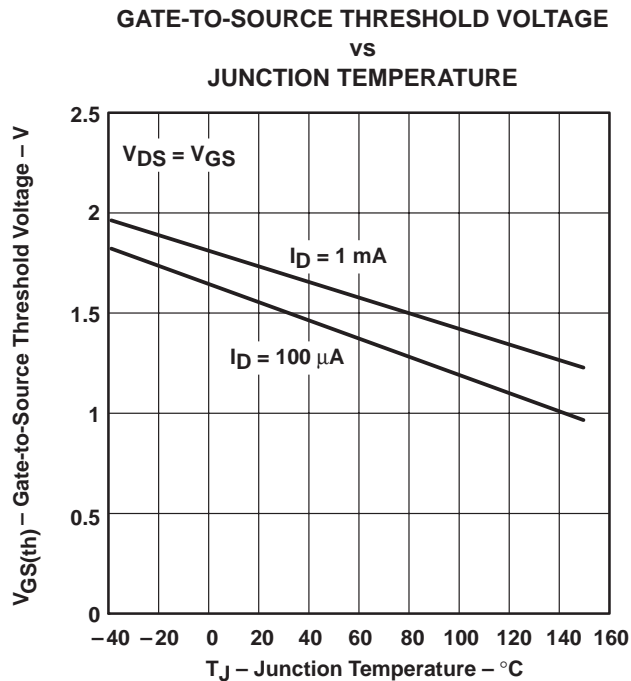

Figure 5

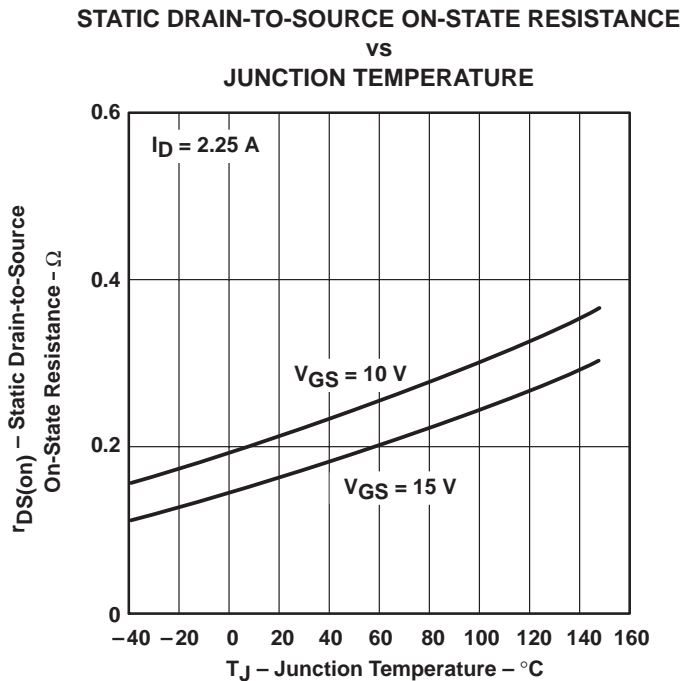

Figure 6

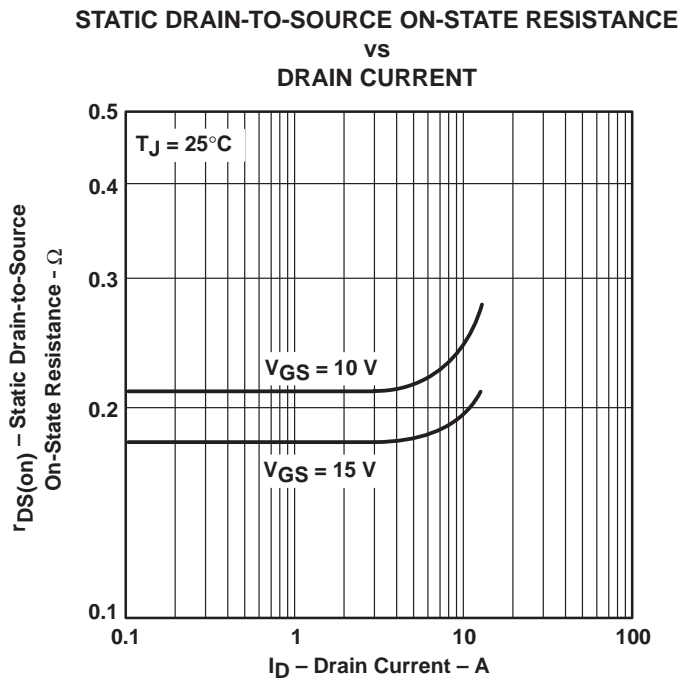

Figure 7

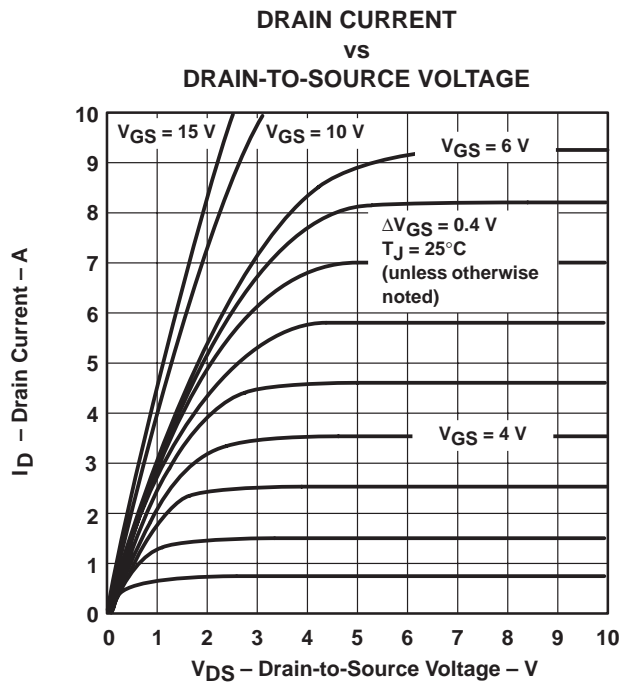

Figure 8

PRODUCT PREVIEW

**TPIC5403**  
**4-CHANNEL INDEPENDENT GATE-PROTECTED**  
**POWER DMOS ARRAY**

SLIS038A – SEPTEMBER 1994 – REVISED SEPTEMBER 1995

**TYPICAL CHARACTERISTICS**

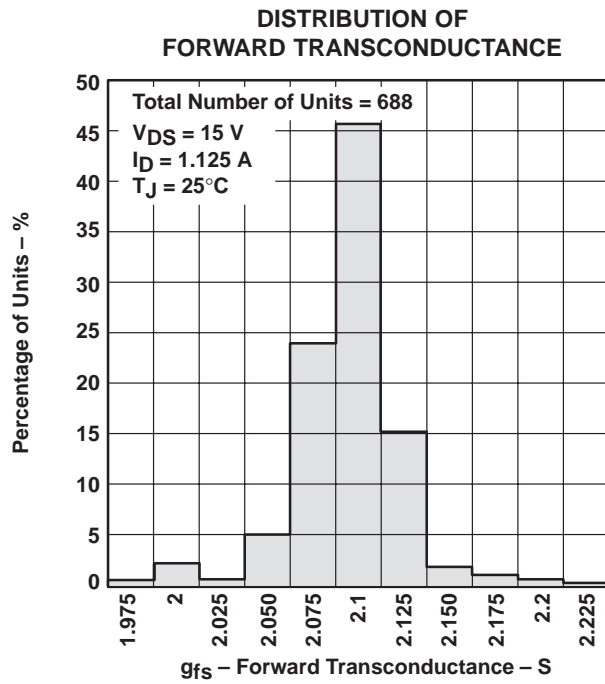

**Figure 9**

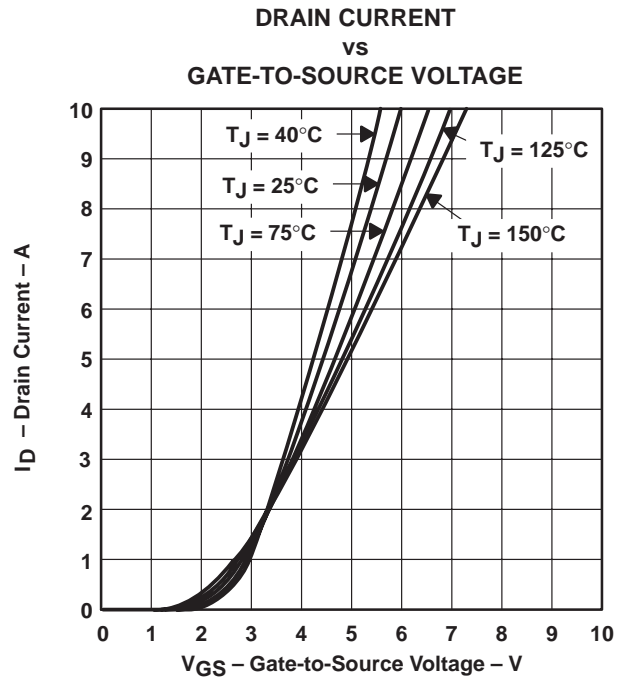

**Figure 10**

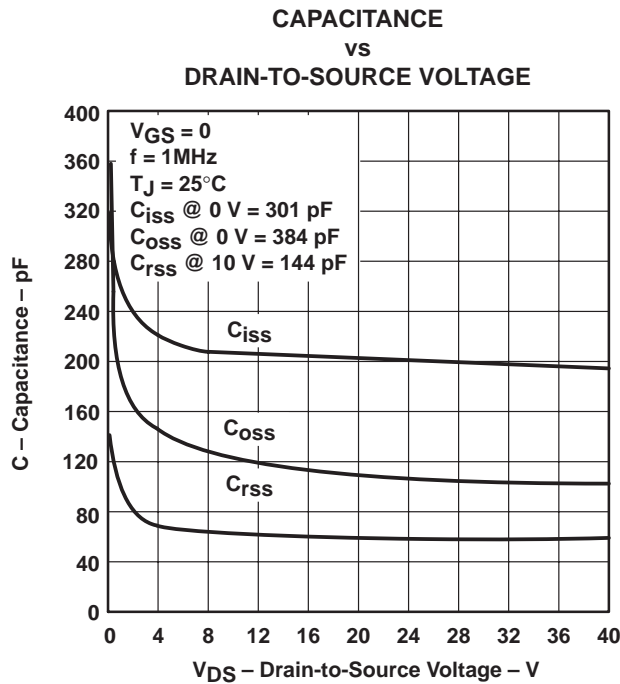

**Figure 11**

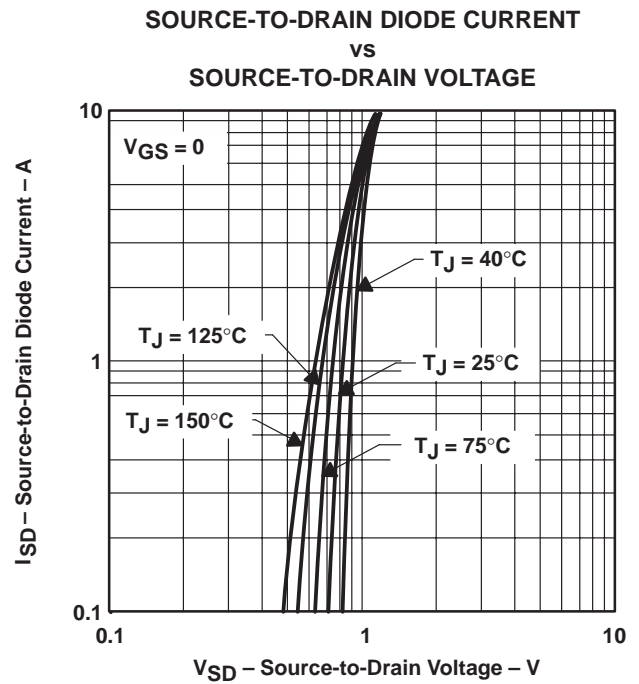

**Figure 12**

**TYPICAL CHARACTERISTICS**

**DRAIN-TO-SOURCE VOLTAGE AND  
GATE-TO-SOURCE VOLTAGE  
vs  
GATE CHARGE**

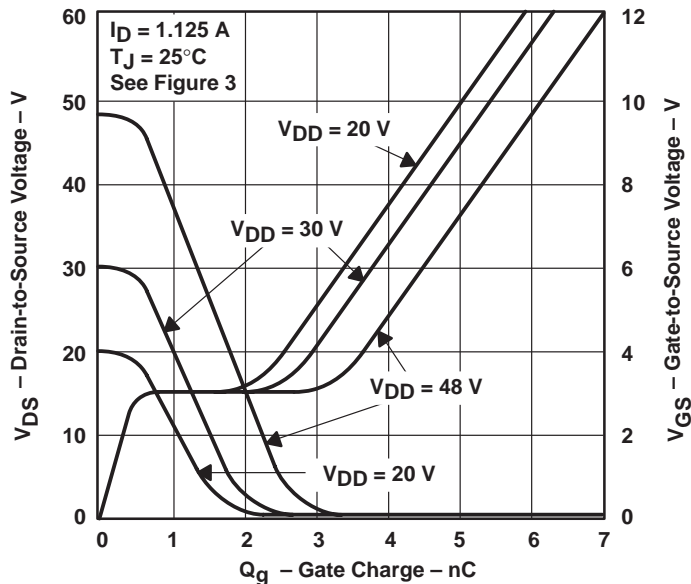

Figure 13

**REVERSE-RECOVERY TIME  
vs  
REVERSE  $di/dt$**

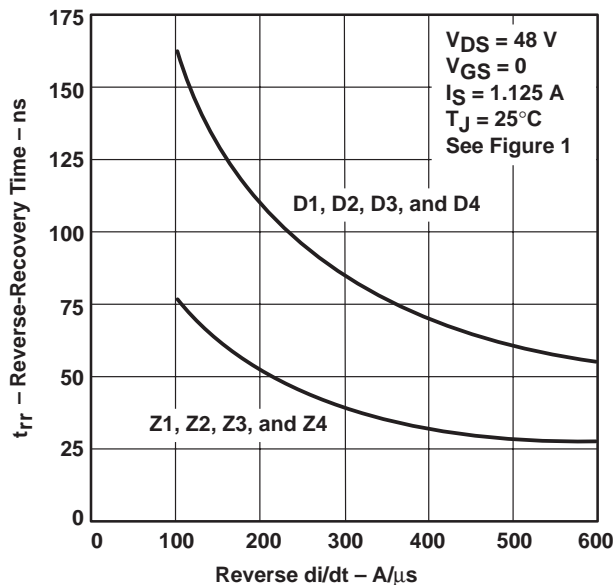

Figure 14

**TPIC5403**  
**4-CHANNEL INDEPENDENT GATE-PROTECTED**  
**POWER DMOS ARRAY**

SLIS038A – SEPTEMBER 1994 – REVISED SEPTEMBER 1995

**THERMAL INFORMATION**

**MAXIMUM DRAIN CURRENT**  
**vs**  
**DRAIN-TO-SOURCE VOLTAGE**

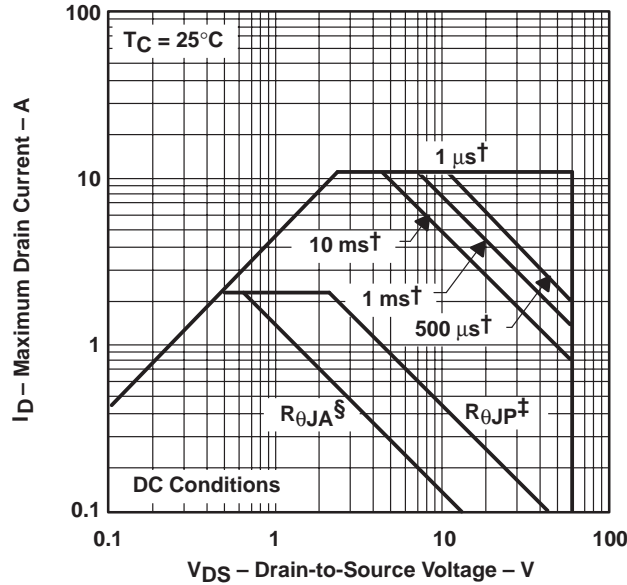

† Less than 2% duty cycle  
 ‡ Device mounted in intimate contact with infinite heatsink.  
 § Device mounted on FR4 printed circuit board with no heatsink.

**Figure 15**

**MAXIMUM PEAK AVALANCHE CURRENT**  
**vs**  
**TIME DURATION OF AVALANCHE**

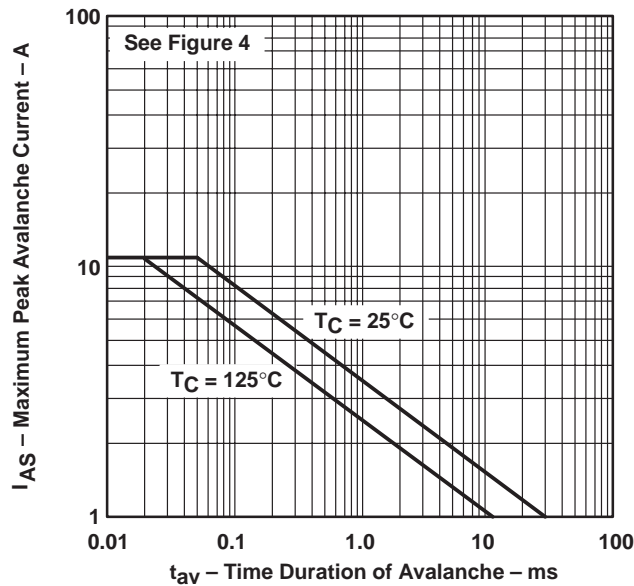
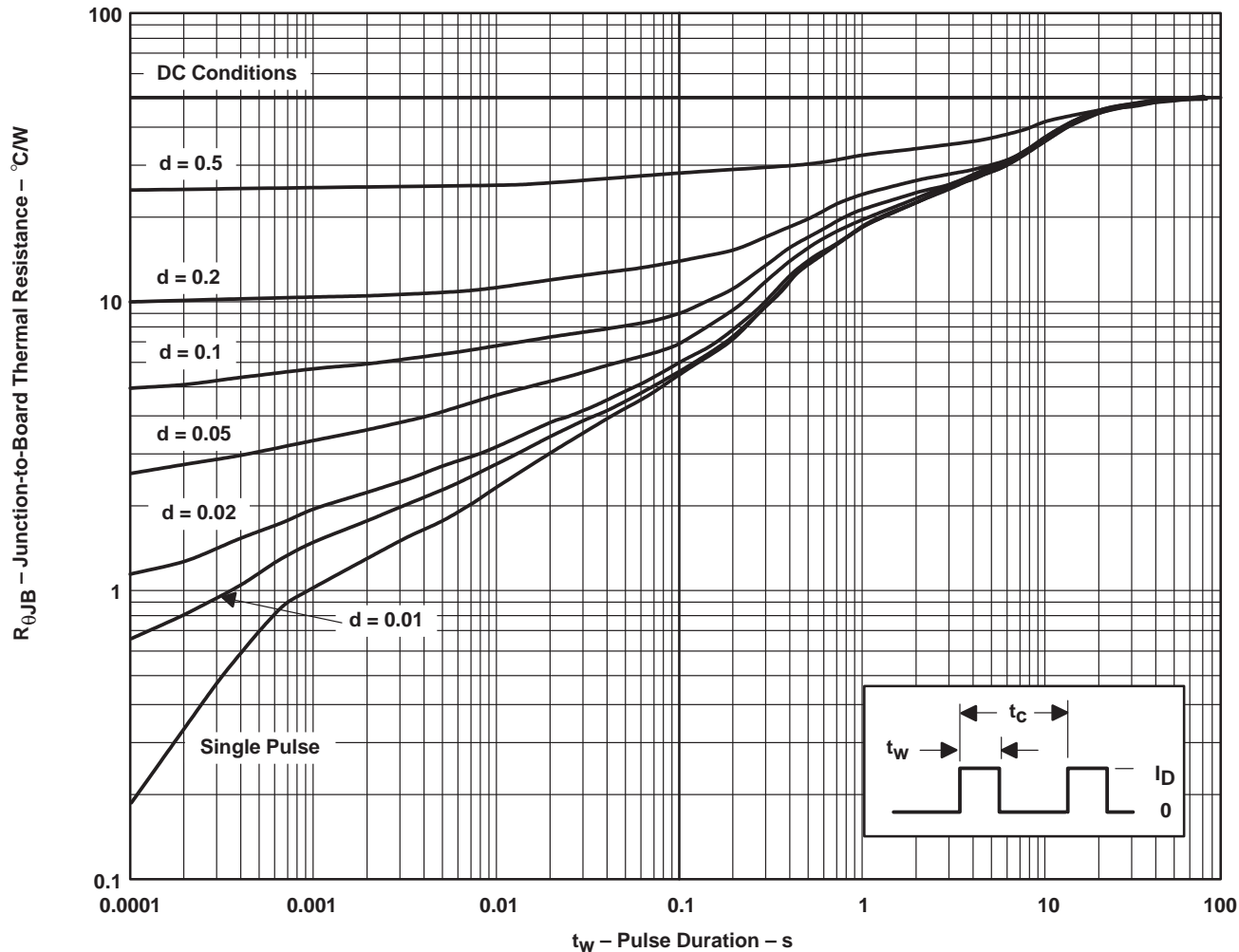

**Figure 16**



THERMAL INFORMATION

DW PACKAGE†  
 JUNCTION-TO-BOARD THERMAL RESISTANCE  
 VS  
 PULSE DURATION



† Device mounted on 24in<sup>2</sup>, 4-layer FR4 printed-circuit board with no heatsink.

NOTE A:  $Z_{\theta JB}(t) = r(t) R_{\theta JB}$   
 $t_w$  = pulse duration  
 $t_c$  = cycle time  
 $d$  = duty cycle =  $t_w/t_c$

Figure 17

**PACKAGING INFORMATION**

Orderable Device	Status <sup>(1)</sup>	Package Type	Package Drawing	Pins	Package Qty	Eco Plan <sup>(2)</sup>	Lead/Ball Finish	MSL Peak Temp <sup>(3)</sup>
TPIC5403DW	OBSOLETE	SOIC	DW	24		TBD	Call TI	Call TI

<sup>(1)</sup> The marketing status values are defined as follows:

**ACTIVE:** Product device recommended for new designs.

**LIFEBUY:** TI has announced that the device will be discontinued, and a lifetime-buy period is in effect.

**NRND:** Not recommended for new designs. Device is in production to support existing customers, but TI does not recommend using this part in a new design.

**PREVIEW:** Device has been announced but is not in production. Samples may or may not be available.

**OBSOLETE:** TI has discontinued the production of the device.

<sup>(2)</sup> Eco Plan - The planned eco-friendly classification: Pb-Free (RoHS) or Green (RoHS & no Sb/Br) - please check <http://www.ti.com/productcontent> for the latest availability information and additional product content details.

**TBD:** The Pb-Free/Green conversion plan has not been defined.

**Pb-Free (RoHS):** TI's terms "Lead-Free" or "Pb-Free" mean semiconductor products that are compatible with the current RoHS requirements for all 6 substances, including the requirement that lead not exceed 0.1% by weight in homogeneous materials. Where designed to be soldered at high temperatures, TI Pb-Free products are suitable for use in specified lead-free processes.

**Green (RoHS & no Sb/Br):** TI defines "Green" to mean Pb-Free (RoHS compatible), and free of Bromine (Br) and Antimony (Sb) based flame retardants (Br or Sb do not exceed 0.1% by weight in homogeneous material)

<sup>(3)</sup> MSL, Peak Temp. -- The Moisture Sensitivity Level rating according to the JEDEC industry standard classifications, and peak solder temperature.

**Important Information and Disclaimer:**The information provided on this page represents TI's knowledge and belief as of the date that it is provided. TI bases its knowledge and belief on information provided by third parties, and makes no representation or warranty as to the accuracy of such information. Efforts are underway to better integrate information from third parties. TI has taken and continues to take reasonable steps to provide representative and accurate information but may not have conducted destructive testing or chemical analysis on incoming materials and chemicals. TI and TI suppliers consider certain information to be proprietary, and thus CAS numbers and other limited information may not be available for release.

In no event shall TI's liability arising out of such information exceed the total purchase price of the TI part(s) at issue in this document sold by TI to Customer on an annual basis.



## IMPORTANT NOTICE

Texas Instruments Incorporated and its subsidiaries (TI) reserve the right to make corrections, modifications, enhancements, improvements, and other changes to its products and services at any time and to discontinue any product or service without notice. Customers should obtain the latest relevant information before placing orders and should verify that such information is current and complete. All products are sold subject to TI's terms and conditions of sale supplied at the time of order acknowledgment.

TI warrants performance of its hardware products to the specifications applicable at the time of sale in accordance with TI's standard warranty. Testing and other quality control techniques are used to the extent TI deems necessary to support this warranty. Except where mandated by government requirements, testing of all parameters of each product is not necessarily performed.

TI assumes no liability for applications assistance or customer product design. Customers are responsible for their products and applications using TI components. To minimize the risks associated with customer products and applications, customers should provide adequate design and operating safeguards.

TI does not warrant or represent that any license, either express or implied, is granted under any TI patent right, copyright, mask work right, or other TI intellectual property right relating to any combination, machine, or process in which TI products or services are used. Information published by TI regarding third-party products or services does not constitute a license from TI to use such products or services or a warranty or endorsement thereof. Use of such information may require a license from a third party under the patents or other intellectual property of the third party, or a license from TI under the patents or other intellectual property of TI.

Reproduction of information in TI data books or data sheets is permissible only if reproduction is without alteration and is accompanied by all associated warranties, conditions, limitations, and notices. Reproduction of this information with alteration is an unfair and deceptive business practice. TI is not responsible or liable for such altered documentation.

Resale of TI products or services with statements different from or beyond the parameters stated by TI for that product or service voids all express and any implied warranties for the associated TI product or service and is an unfair and deceptive business practice. TI is not responsible or liable for any such statements.

Following are URLs where you can obtain information on other Texas Instruments products and application solutions:

<b>Products</b>		<b>Applications</b>	
Amplifiers	<a href="http://amplifier.ti.com">amplifier.ti.com</a>	Audio	<a href="http://www.ti.com/audio">www.ti.com/audio</a>
Data Converters	<a href="http://dataconverter.ti.com">dataconverter.ti.com</a>	Automotive	<a href="http://www.ti.com/automotive">www.ti.com/automotive</a>
DSP	<a href="http://dsp.ti.com">dsp.ti.com</a>	Broadband	<a href="http://www.ti.com/broadband">www.ti.com/broadband</a>
Interface	<a href="http://interface.ti.com">interface.ti.com</a>	Digital Control	<a href="http://www.ti.com/digitalcontrol">www.ti.com/digitalcontrol</a>
Logic	<a href="http://logic.ti.com">logic.ti.com</a>	Military	<a href="http://www.ti.com/military">www.ti.com/military</a>
Power Mgmt	<a href="http://power.ti.com">power.ti.com</a>	Optical Networking	<a href="http://www.ti.com/opticalnetwork">www.ti.com/opticalnetwork</a>
Microcontrollers	<a href="http://microcontroller.ti.com">microcontroller.ti.com</a>	Security	<a href="http://www.ti.com/security">www.ti.com/security</a>
		Telephony	<a href="http://www.ti.com/telephony">www.ti.com/telephony</a>
		Video & Imaging	<a href="http://www.ti.com/video">www.ti.com/video</a>
		Wireless	<a href="http://www.ti.com/wireless">www.ti.com/wireless</a>

Mailing Address: Texas Instruments  
Post Office Box 655303 Dallas, Texas 75265