



CMOS Analog Switches

(Obsolete for non-hermetic. Use DG303B as pin-for-pin replacements.)

FEATURES

- Analog Signal Range: $\pm 15\text{ V}$
- Fast Switching— t_{ON} : 150 ns
- Low On-Resistance— $r_{DS(on)}$: 30 Ω
- Single Supply Operation
- Latch-up Proof
- CMOS Compatible

BENEFITS

- Full Rail-to-Rail Analog Signal Range
- Low Signal Error
- Low Power Dissipation

APPLICATIONS

- Low Level Switching Circuits
- Programmable Gain Amplifiers
- Portable and Battery Powered Systems

DESCRIPTION

The DG303A_MIL is a monolithic CMOS switch in a DPST configuration for precision applications in communications, instrumentation and process control, where low leakage switching combined with low power consumption are required.

In the on condition the switches conduct equally well in both directions (with no offset voltage) and minimize error conditions with their low on-resistance.

Designed on the Vishay Siliconix PLUS-40 CMOS process, these switches are latch-up proof, and are designed to block up to 30 V peak-to-peak when off. An epitaxial layer prevents latchup.

Featuring low power consumption (3.5 mW typ) these switches are ideal for battery powered applications, without sacrificing switching speed. Designed for break-before-make switching action, these devices are CMOS and quasi TTL compatible. Single supply operation is allowed by connecting the V- rail to 0 V.

FUNCTIONAL BLOCK DIAGRAM AND PIN CONFIGURATION

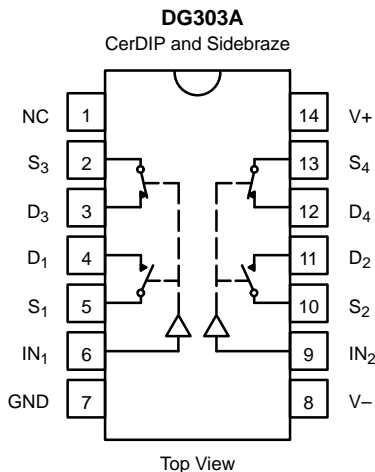

TRUTH TABLE		
Logic	SW ₁ , SW ₂	SW ₃ , SW ₄
0	OFF	ON
1	ON	OFF

Logic "0" $\leq 0.8\text{ V}$
Logic "1" $\geq 4\text{ V}$

ORDERING INFORMATION		
Temp Range	Package	Part Number
-55 to 125°C	14-Pin CerDIP	DG303AAK
		DG303AAK/883
		JM38510/11604BCA
	14-Pin Sidebraze	JM38510/11604BCC

ABSOLUTE MAXIMUM RATINGS

Voltages Referenced to V-

V+	44 V
GND	25 V
Digital Inputs ^a , V _S , V _D	(V-) -2 V to (V+) +2V or 30 mA, whichever occurs first
Current, Any Terminal	30 mA
Continuous Current, S or D (Pulsed at 1 ms, 10% duty cycle max)	100 mA

Storage Temperature (A Suffix)	-65 to 150°C
Power Dissipation ^b	
14-Pin CerDIP ^c	825 mW

- Notes:
- Signals on S_X, D_X, or IN_X exceeding V+ or V- will be clamped by internal diodes. Limit forward diode current to maximum current ratings.
 - Derate 6.5 mW/°C above 25°C
 - Derate 11 mW/°C above 75°C

SCHEMATIC DIAGRAM (TYPICAL CHANNEL)

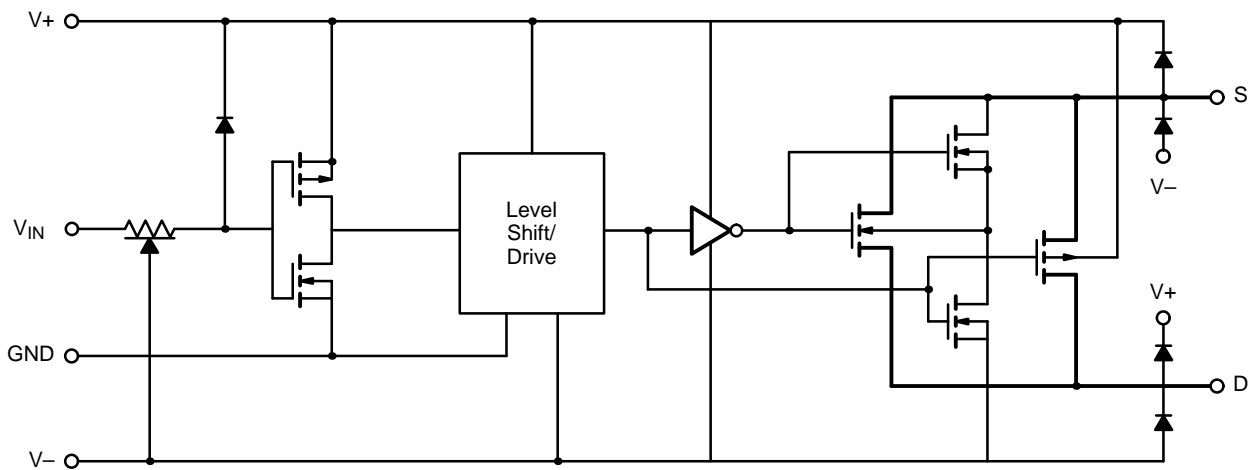

FIGURE 1.



SPECIFICATIONS ^a							
Parameter	Symbol	Test Conditions Unless Specified $V_+ = 15\text{ V}$, $V_- = -15\text{ V}$ $V_{IN} = 0.8\text{ V}$ or $V_{IN} = 4\text{ V}$ ^f	Temp ^b	Limits -55 to 125°C			Unit
				Min ^d	Typ ^c	Max ^d	
Analog Switch							
Analog Signal Range ^e	V_{ANALOG}		Full	-15		15	V
Drain-Source On-Resistance	$r_{DS(on)}$	$V_D = \pm 10\text{ V}$, $I_S = -10\text{ mA}$	Room Full		30	50 75	Ω
Source Off Leakage Current	$I_{S(off)}$	$V_S = \pm 14\text{ V}$, $V_D = \mp 14\text{ V}$	Room Hot	-1 -100	± 0.1	1 100	nA
Drain Off Leakage Current	$I_{D(off)}$		Room Hot	-1 -100	± 0.1	1 100	
Drain On Leakage Current	$I_{D(on)}$	$V_D = V_S = \pm 14\text{ V}$	Room Hot	-1 -100	± 0.1	1 100	
Digital Control							
Input Current with Input Voltage High	I_{INH}	$V_{IN} = 5\text{ V}$	Room Full	-1 -1	-0.001		μA
		$V_{IN} = 15\text{ V}$	Room Full		0.001	1 1	
Input Current with Input Voltage Low	I_{INL}	$V_{IN} = 0\text{ V}$	Room Full	-1 -1	-0.001		
Dynamic Characteristics							
Turn-On Time	t_{ON}	See Figure 2	Room		150	300	ns
Turn-Off Time	t_{OFF}		Room		130	250	
Break-Before-Make Time	t_{OPEN}	Figure 3	Room		50		
Charge Injection	Q	$C_L = 1\text{ nF}$, $R_{gen} = 0\ \Omega$, $V_{gen} = 0\text{ V}$, Figure 4	Room		8		pC
Source-Off Capacitance	$C_{S(off)}$	V_S , $V_D = 0\text{ V}$, $f = 1\text{ MHz}$	Room		14		pF
Drain-Off Capacitance	$C_{D(off)}$		Room		14		
Channel-On Capacitance	$C_{D(on)}$		Room		40		
Input Capacitance	C_{in}	$f = 1\text{ MHz}$	$V_{IN} = 0\text{ V}$	Room		6	
			$V_{IN} = 15\text{ V}$	Room		7	
Off-Isolation	OIRR	$V_{IN} = 0\text{ V}$, $R_L = 1\text{ k}\Omega$ $V_S = 1\text{ V}_{rms}$, $f = 500\text{ kHz}$	Room		62		dB
Crosstalk (Channel-to-Channel)	X_{TALK}		Room		74		
Power Supplies							
Positive Supply Current	I_+	$V_{IN} = 4\text{ V}$ (One Input) All Others = 0 V	Room Full		0.23	0.5 1	mA
Negative Supply Current	I_-		Room Full	-10 -100	-0.001		
Positive Supply Current	I_+	$V_{IN} = 0.8\text{ V}$ (All Inputs)	Room Full		0.001	10 100	μA
Negative Supply Current	I_-		Room Full	-10 -100	-0.001		

Notes:

- Refer to PROCESS OPTION FLOWCHART.
- Room = 25°C, Full = as determined by the operating temperature suffix.
- Typical values are for DESIGN AID ONLY, not guaranteed nor subject to production testing.
- The algebraic convention whereby the most negative value is a minimum and the most positive a maximum, is used in this data sheet.
- Guaranteed by design, not subject to production test.
- V_{IN} = input voltage to perform proper function.

TYPICAL CHARACTERISTICS (25°C UNLESS NOTED)

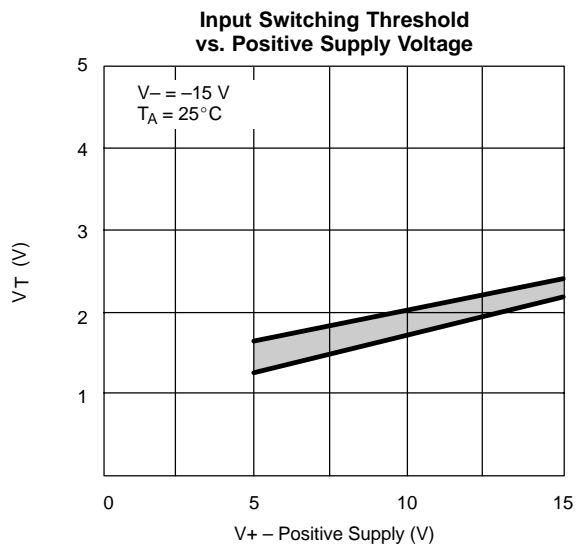
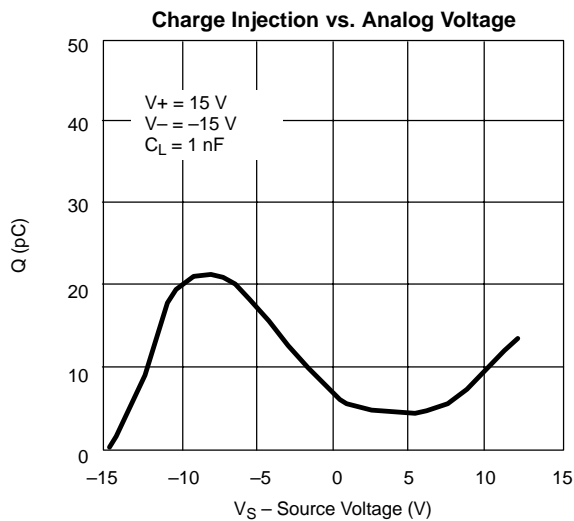
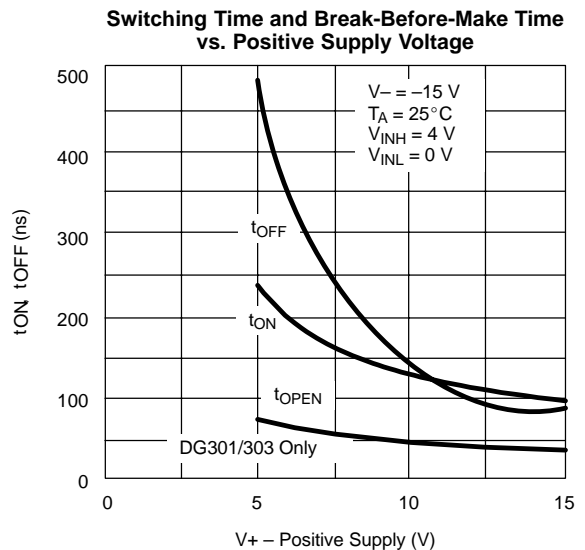
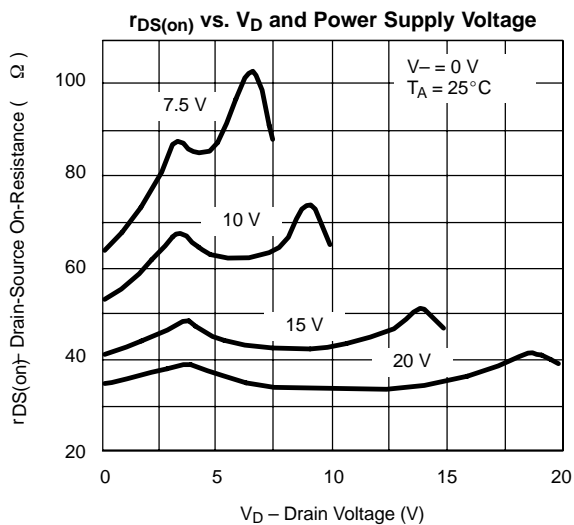
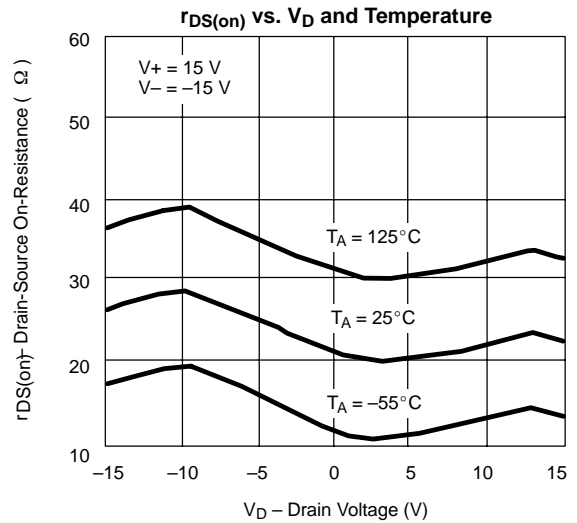
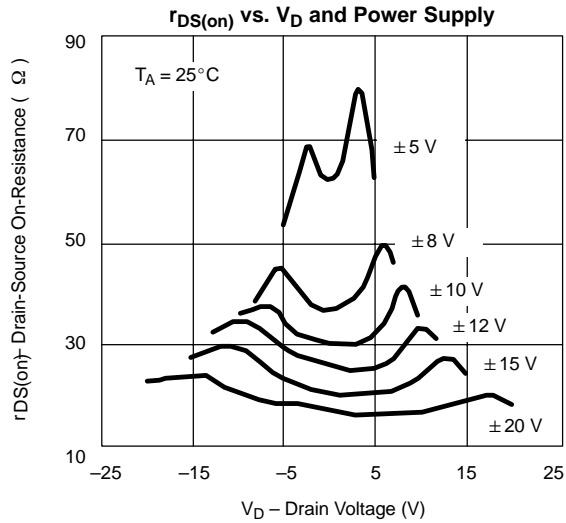



TYPICAL CHARACTERISTICS (25°C UNLESS NOTED)

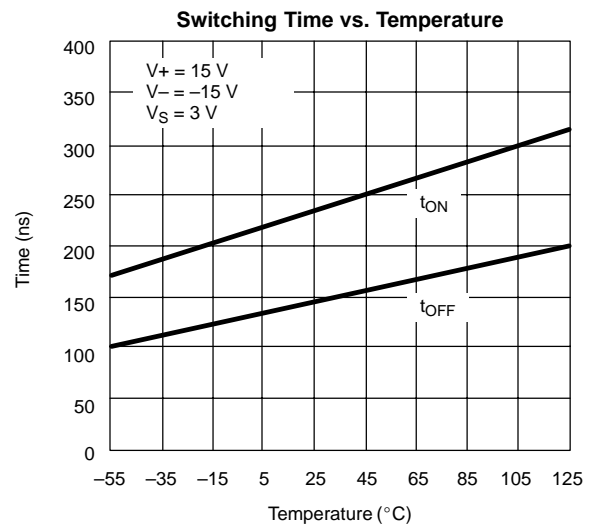
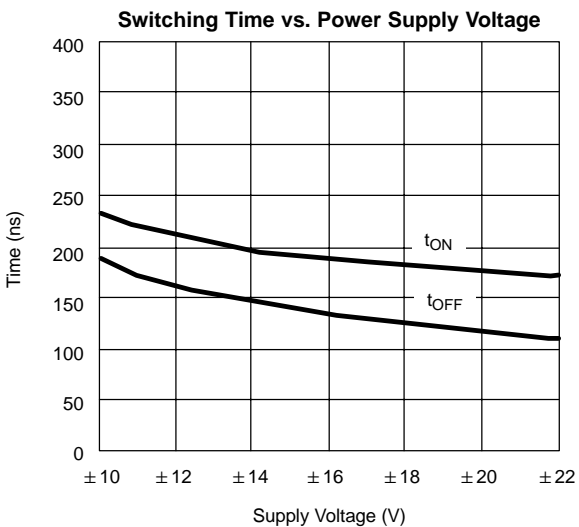
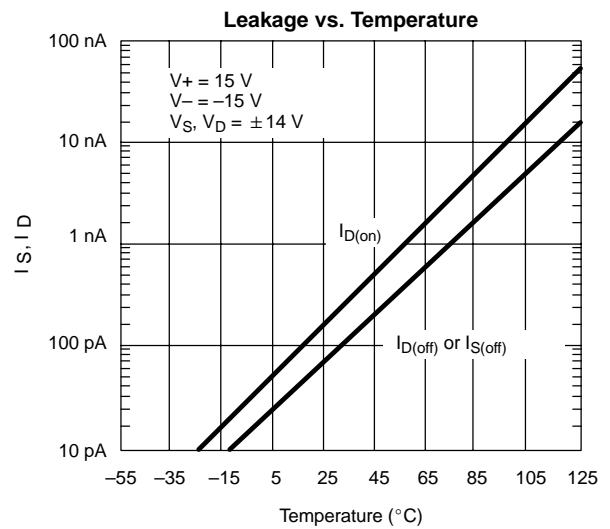
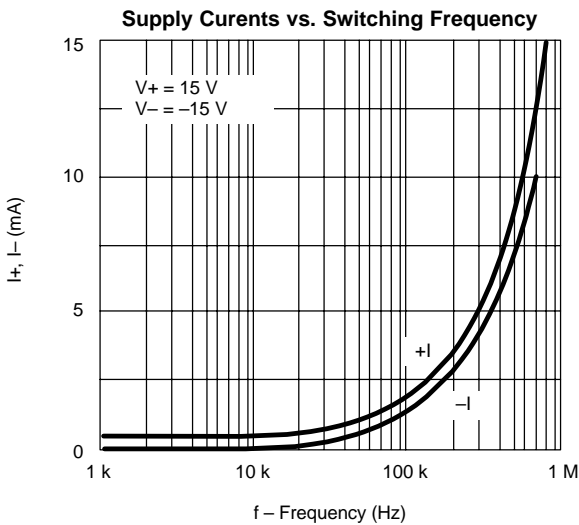
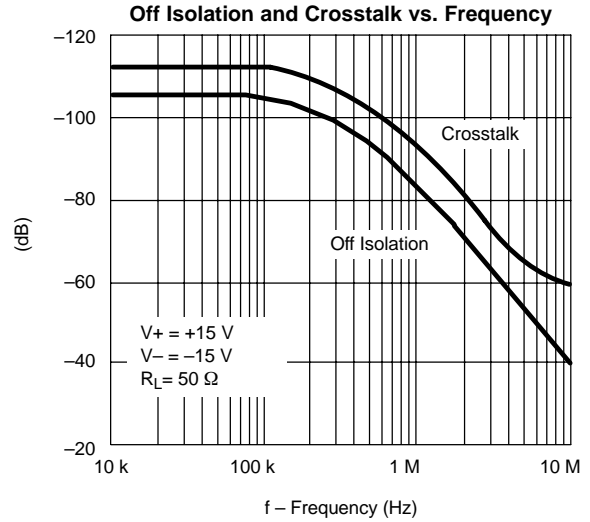
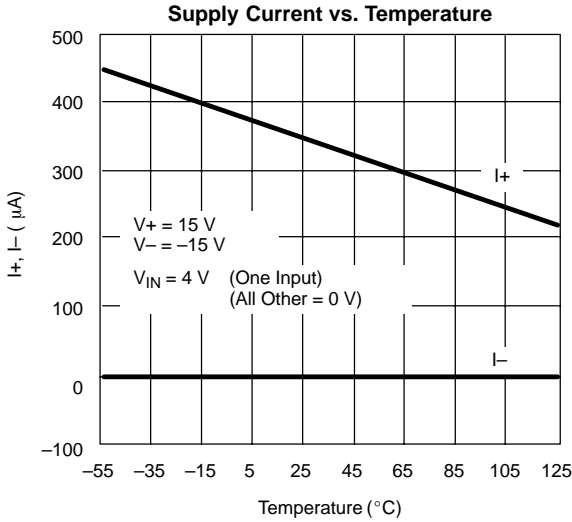

TEST CIRCUITS

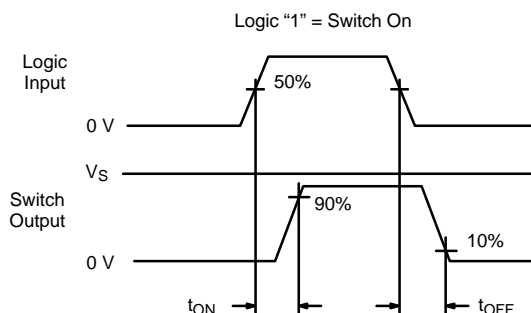
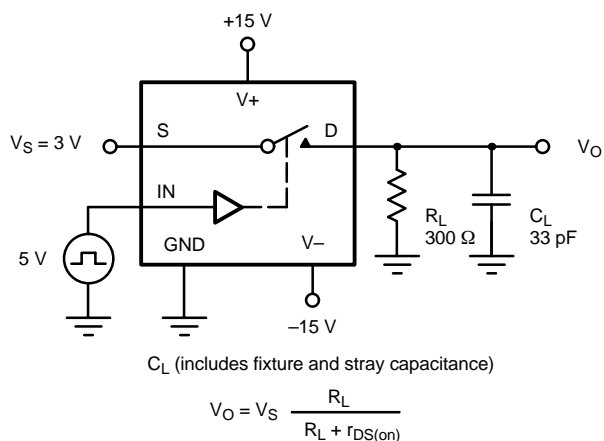

FIGURE 2. Switching Time

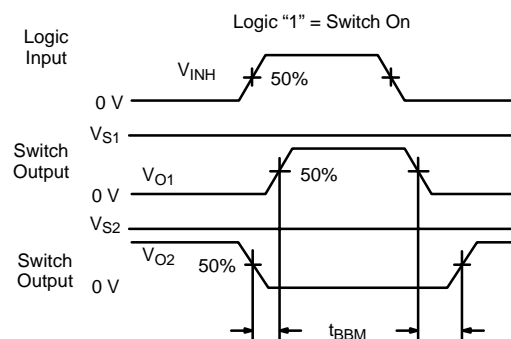
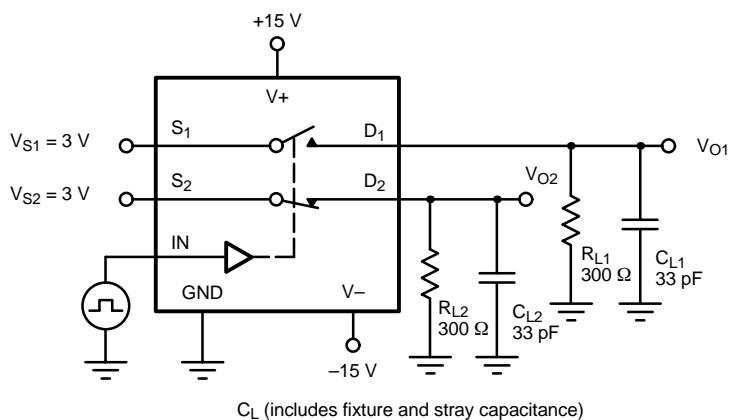

FIGURE 3. Break-Before-Make SPDT

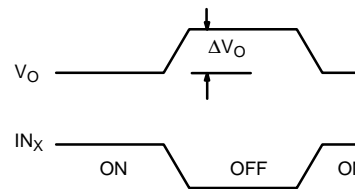
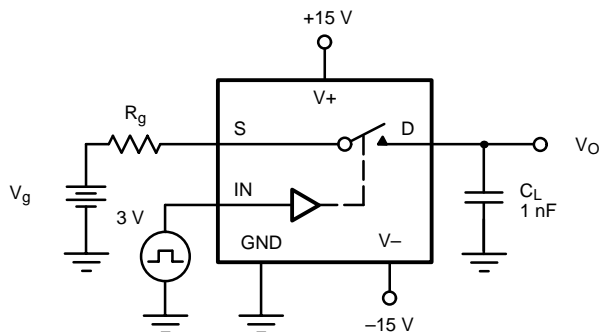

FIGURE 4. Charge Injection



APPLICATION HINTS^a				
V+ Positive Supply Voltage (V)	V- Negative Supply Voltage (V)	GND Voltage (V)	V_{IN} Logic Input Voltage V_{INH(min)}/V_{INL(max)} (V)	V_S or V_D Analog Voltage Range (V)
15	-15	0	4/0.8	-15 to 15
20	-20	0	4/0.8	-20 to 20
15	0	0	4/0.8	0 to 15

Note:

a. Application Hints are for DESIGN AID ONLY, not guaranteed and not subject to production testing.



Disclaimer

All product specifications and data are subject to change without notice.

Vishay Intertechnology, Inc., its affiliates, agents, and employees, and all persons acting on its or their behalf (collectively, "Vishay"), disclaim any and all liability for any errors, inaccuracies or incompleteness contained herein or in any other disclosure relating to any product.

Vishay disclaims any and all liability arising out of the use or application of any product described herein or of any information provided herein to the maximum extent permitted by law. The product specifications do not expand or otherwise modify Vishay's terms and conditions of purchase, including but not limited to the warranty expressed therein, which apply to these products.

No license, express or implied, by estoppel or otherwise, to any intellectual property rights is granted by this document or by any conduct of Vishay.

The products shown herein are not designed for use in medical, life-saving, or life-sustaining applications unless otherwise expressly indicated. Customers using or selling Vishay products not expressly indicated for use in such applications do so entirely at their own risk and agree to fully indemnify Vishay for any damages arising or resulting from such use or sale. Please contact authorized Vishay personnel to obtain written terms and conditions regarding products designed for such applications.

Product names and markings noted herein may be trademarks of their respective owners.