

### DESCRIPTION

The MP24183 is a 55V, 1A, white LED driver suitable for either step-down or inverting step-up/down applications. It achieves 1A peak output current over a wide input supply range with excellent load and line regulation. Current mode operation provides fast transient response and eases loop stabilization. Fault condition protection includes thermal shutdown, cycle-by-cycle peak current limiting, input over voltage protection, open strings protection and output short circuit protection.

The MP24183 incorporates both DC and PWM dimming onto a single control pin. The separate input reference ground pin allows for direct enable and/or dimming control for a positive to negative power conversion.

The MP24183 requires a minimum number of readily available standard external components and is available in 10-pin 3mm x 3mm QFN packages.

### MP24183DQ DEMO BOARDS

Board number	Operating Mode	Input (V)	LED #	I <sub>LED</sub> (mA)
EV24183DQ-00A	Buck	15~50	3	700
EV24183DQ-00B	Buck-boost	12	3~5	500
EV24183DQ-00C	Boost	12	6~9	500

### FEATURES

- 1A Maximum Output Current
- Unique Step-up/down Operation (Buck-Boost Mode)
- Wide 4.5V to 55V Operating Input Range for Step-Down Applications (Buck Mode)
- 0.28Ω Internal Power MOSFET Switch
- Adjustable Switching Frequency
- Analog and PWM Dimming
- 0.198V Reference Voltage
- 5μA Shutdown Mode
- No minimum LED required
- Stable with Low ESR Output Ceramic Capacitors
- Cycle-by-Cycle Over Current Protection
- Thermal Shutdown Protection
- Open Strings Protection
- Input Over Voltage Protection
- Output Short Circuit Protection
- Available in 10-Pin 3x3mm QFN Package

### APPLICATIONS

- General LED Illuminations
- LCD Backlight Panels
- Handheld Computers
- Automotive Internal Lighting
- Portable Multimedia Players
- Portable GPS Devices

All MPS parts are lead-free and adhere to the RoHS directive. For MPS green status, please visit MPS website under Products, Quality Assurance page. "MPS" and "The Future of Analog IC Technology" are registered trademarks of Monolithic Power Systems, Inc.

## EV24183DQ-00B EVALUATION BOARD



(L x W x H) 5cm x 4.5cm x 0.7cm

Board Number	MPS IC Number
EV24183DQ-00B	MP24183DQ

## EVALUATION BOARD SCHEMATIC

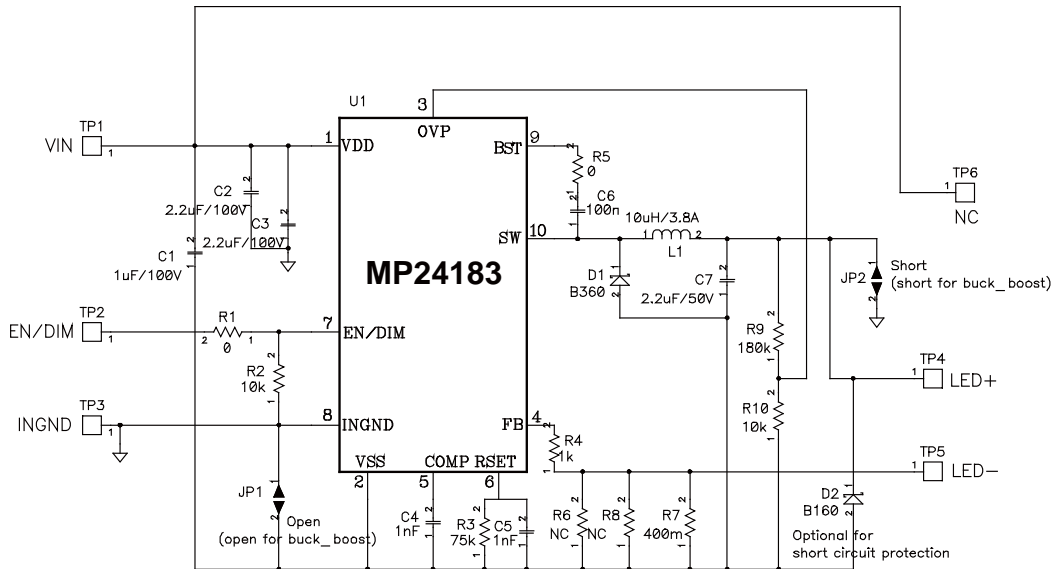

## EV24183DQ-00B BILL OF MATERIALS

Qty	Ref	Value	Description	Package	Manufacturer	Manufacturer P/N
1	C1	1µF	Ceramic Capacitor,100V,X7R	1210	Murata	GRM32ER72A105KA01L
2	C2,C3	2.2µF	Ceramic Capacitor,100V,X7R	1210	Murata	GRM32ER72A225KA35L
2	C4,C5	1n	Ceramic Capacitor,50V,X7R	0603	TDK	C1608X7R1H102K
1	C6	100n	Ceramic Capacitor,50V,X7R	0603	TDK	C1608X7R1H104K
1	C7	2.2µF	Ceramic Capacitor,50V,X7R	1210	TDK	C3225X7R1H225K
1	D1	B360	Diode Schottky	SMA	Diodes Inc.	B360A
1	D2	B160	Diode Schottky	SMA	Diodes Inc.	B160A
1	L1	10µH	Inductor 3.7A,22mΩ	SM	TOKO	DH124C-1010ASW-100M
		10µH	Inductor 3.8A, 35mΩ	SM	Cooper	DR1040-100-R
		10µH	inductor 3.8A, 28mΩ	SM	TDK	VLF10040-100M3R8
1	R4	1k	resistor, 1%	0603	Yageo	RC0603JR-071kL
2	R1,R5	0	resistor, 1%	0603	Yageo	RC0603JR-070RL
2	R2,R10	10kΩ	resistor, 1%	0603	Yageo	RC0603FR-0710kL
1	R3	75kΩ	resistor, 1%	0603	Yageo	RC0603FR-0775kL
2	R6,R8	NC		0805		
1	R7	400m	resistor, 1%	0805	ROYALOHM	0805F400LT5E
1	R9	180kΩ	resistor, 1%	0603	Yageo	RC0603FR-07180kL
1	U1	MP24183DQ	MPS WLED Driver, 1A, 55V, frequency programmable	QFN3*3	MPS	MP24183DQ

**PRINTED CIRCUIT BOARD LAYOUT**

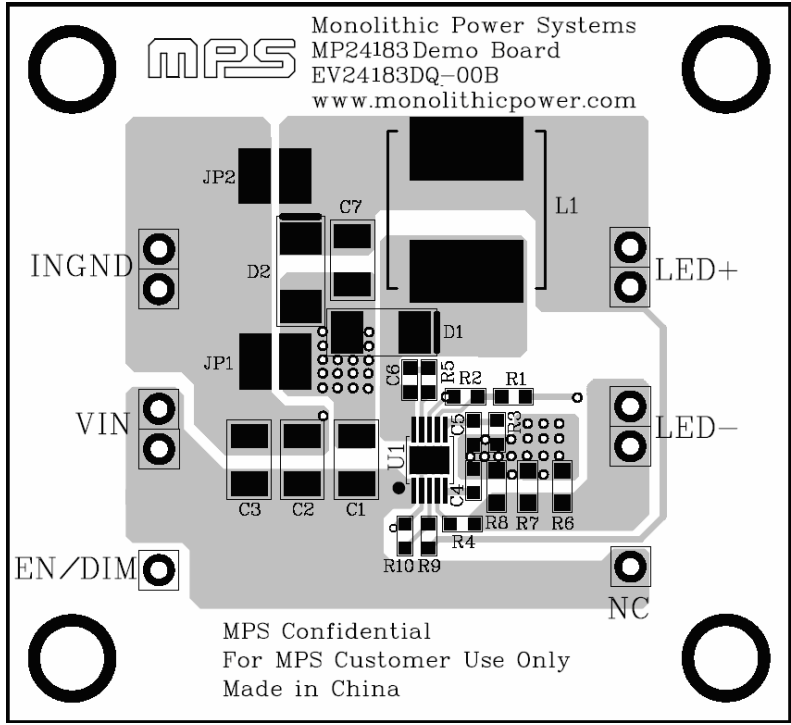

**Figure 1—Top Layer**

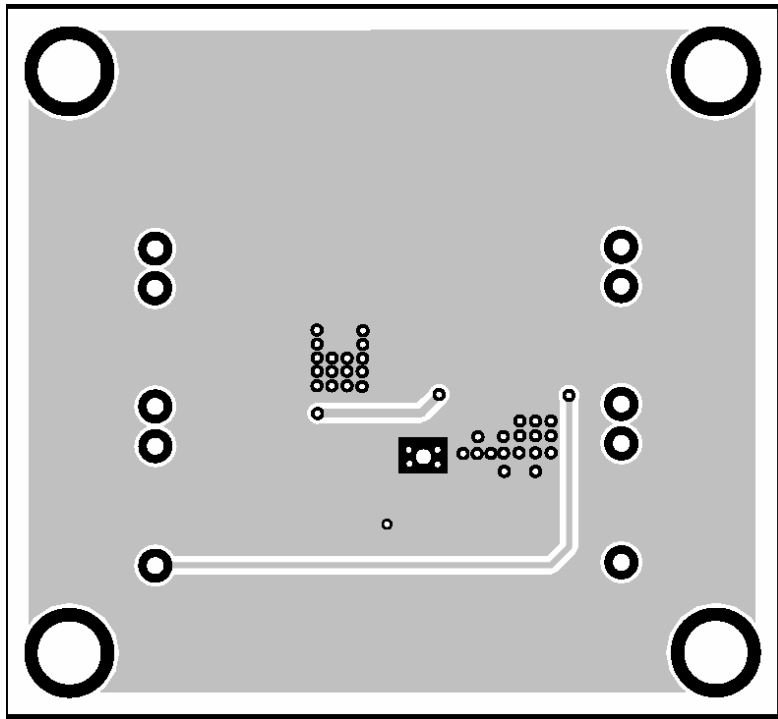

**Figure 2—Bottom Layer**

## QUICK START GUIDE

1. Connect the load (3~5LEDs) to the output. The Anode of the load to “LED+” and the Cathode of the load to “LED -”.
2. Connect the input voltage source to the input VIN and INGND. The input voltage source should be initialed 12V.
3. Connect the EN or dimming signal to EN/Dim pin.

For PWM dimming, connect the PWM signal to EN/Dim pin, the high level should be higher than 1.4V, the low level should be lower than 0.7V.

For analog dimming, connect a DC dimming signal in range of 0.7V~1.4V to EN/Dim pin.

4. Power up the input voltage source, and then power up the EN/Dim signal, the LEDs should be ignited

**NOTICE:** The information in this document is subject to change without notice. Please contact MPS for current specifications. Users should warrant and guarantee that third party Intellectual Property rights are not infringed upon when integrating MPS products into any application. MPS will not assume any legal responsibility for any said applications.