



DESCRIPTION

The A4806 series is a series of high-precision voltage detectors developed using CMOS process. The detection voltage is fixed internally with an accuracy of $\pm 2.0\%$. Two output forms, Nch open-drain and CMOS output, are available. Ultra-low current consumption and miniature package lineup can meet demand from the portable device applications.

A4806 is available in SOT-23 package.

ORDERING INFORMATION

| Package Type | Part Number | |
|--------------------------------|---|---------------|
| SOT-23 SPQ: 3,000pcs/Reel | E3 | A4806E3R-XXZ |
| | | A4806E3VR-XXZ |
| Note | XX: Detect Voltage 29=2.9V, 33=3.3V Z: N=Nch, C=CMOS V: Halogen free Package R: Tape & Reel | |
| AiT provides all RoHS products | | |

FEATURES

- Ultra-low current consumption 2.0 μ A typ. ($V_{in}=1.5V$)
- High-precision detection voltage $\pm 2.0\%$
- Operating voltage range 0.7V to 8.0V
- Detection voltage 1.0V to 6.0V (0.1V step)
- Output form Nch open-drain output (Active Low) or CMOS output (Active Low)
- Available in SOT-23 Package

APPLICATION

- Battery checkers
- Power failure detectors
- Power monitor for portable equipments such as pagers, calculators, electronic notebooks and remote controllers.
- Constant voltage power monitor for cameras, video equipments and communication devices.
- Power monitor for microcomputers and reset for CPUs.

TYPICAL APPLICATION

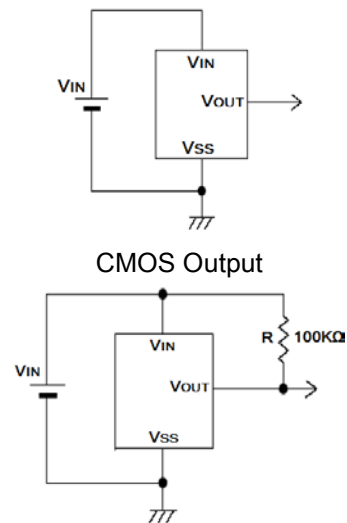



PIN DESCRIPTION

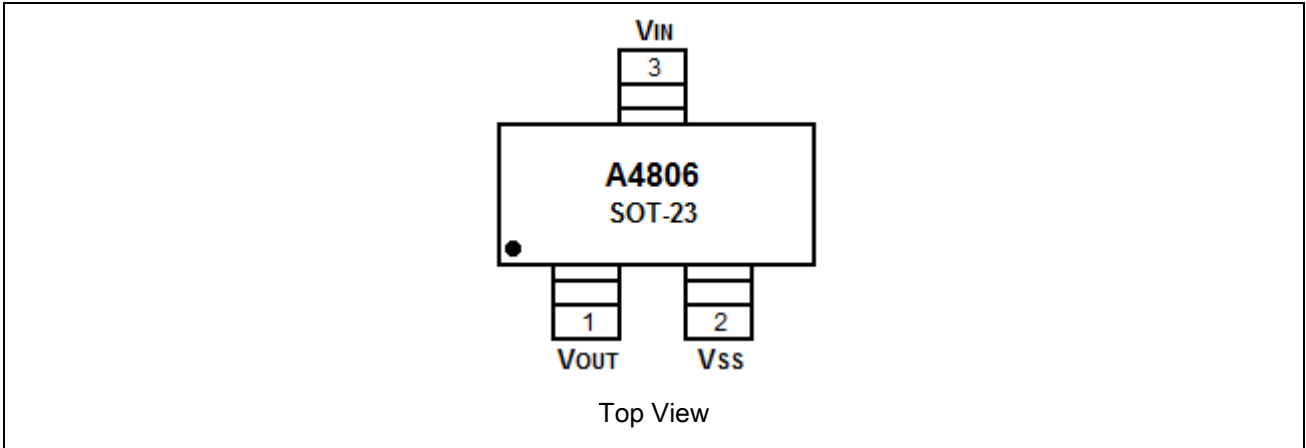

| Pin # | Symbol | Function |
|-------|------------------|-------------------|
| 1 | V _{OUT} | Output pin |
| 2 | V _{SS} | GND pin |
| 3 | V _{IN} | Voltage Input pin |



ABSOLUTE MAXIMUM RATINGS

T_A = 25°C

| | |
|--|--|
| V _{IN} , Power Supply Voltage | 8V |
| I _{OUT} , Output Current | 50mA |
| V _{OUT} , Output Voltage | CMOS V _{SS} -0.3V ~ V _{IN} +0.3V |
| | N-ch V _{SS} -0.3V ~ 8V |
| P _D , Power Dissipation | SOT-23 150mW |
| T _{OPR} , Operating Ambient Temperature | -40°C ~ +85°C |

Stress beyond above listed "Absolute Maximum Ratings" may lead permanent damage to the device. These are stress ratings only and operations of the device at these or any other conditions beyond those indicated in the operational sections of the specifications are not implied. Exposure to absolute maximum rating conditions for extended periods may affect device reliability.

ELECTRICAL CHARACTERISTICS

V_{DF(T)} = 1.0 to 6.0V ±2% T_A = 25°C

| Parameter | Symbol | Conditions | Min | Typ. | Max | Unit | Test circuit | |
|-------------------------|------------------|---|------------------------|-----------------------|-----------------------|------------|--------------|---|
| Detection Voltage | V _{DF} | | V _{DF} ×0.98 | V _{DF} | V _{DF} ×1.02 | V | 1 | |
| Release Voltage | V _{HYS} | | - | V _{DF} ×0.05 | - | V | 1 | |
| Current Consumption | I _{SS} | V _{IN} = 1.0V | - | 2.0 | 2.2 | uA | 2 | |
| | | V _{IN} = 1.5V | - | 2.0 | 2.4 | | | |
| | | V _{IN} = 2.0V | - | 2.0 | 2.8 | | | |
| | | V _{IN} = 3.0V | - | 2.0 | 3.1 | | | |
| | | V _{IN} = 4.0V | - | 2.0 | 3.3 | | | |
| | | V _{IN} = 5.0V | - | 2.0 | 3.7 | | | |
| Operating voltage | V _{IN} | V _{DF} = 1.0 ~ 6.0V | 0.7 | - | 8 | V | 1 | |
| Output current | I _{OUT} | Nch V _{DS} = 0.5V | V _{IN} = 1.0V | 1.0 | 2.2 | - | mA | 3 |
| | | | V _{IN} = 1.5V | 2.0 | 5.7 | - | | |
| | | | V _{IN} = 2.0V | 3.0 | 7.7 | - | | |
| | | | V _{IN} = 3.0V | 5.0 | 10.1 | - | | |
| | | | V _{IN} = 4.0V | 6.0 | 11.5 | - | | |
| | | | V _{IN} = 5.0V | 7.0 | 13.0 | - | | |
| | | Pch V _{DS} = 2.1 V _{IN} = 8.0 | - | -10 | -2 | 4 | | |
| Temperature Coefficient | | -40~+85°C | - | ±100 | - | ppm/ °C | | |



TEST CIRCUIT

Circuit 1

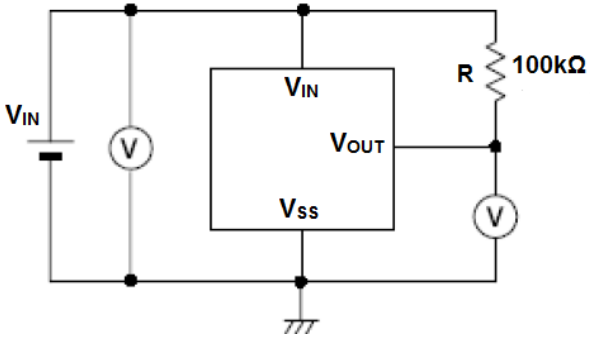

Circuit 2

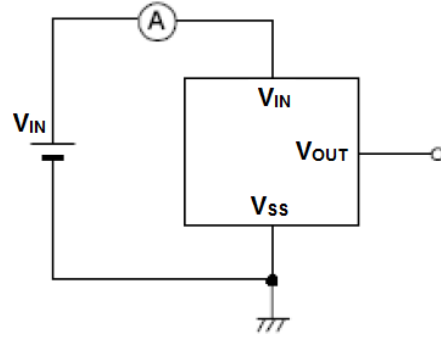

Circuit 3

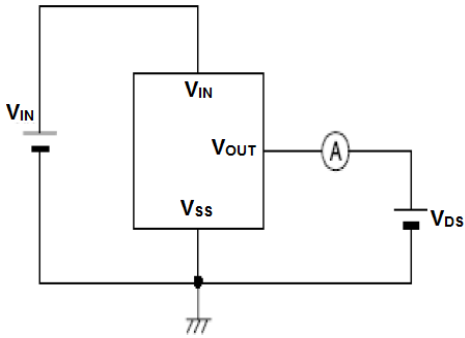

Circuit 4

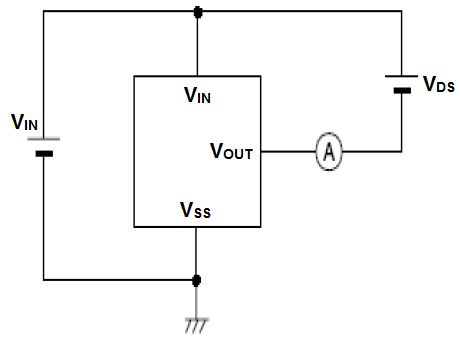



BLOCK DIAGRAM

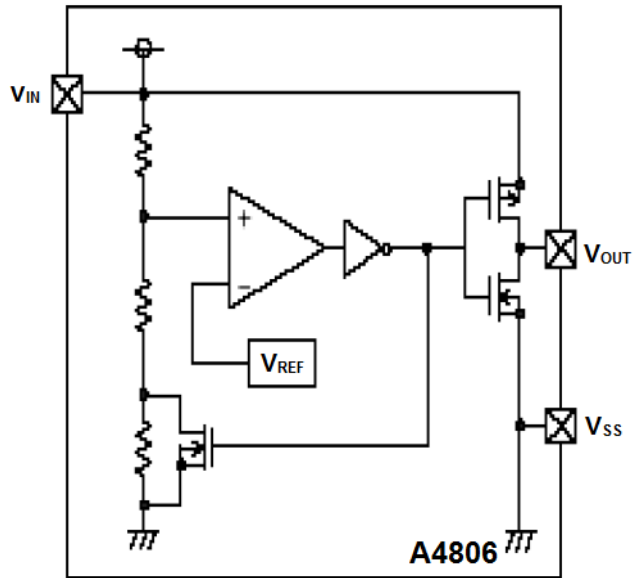

CMOS Output Products

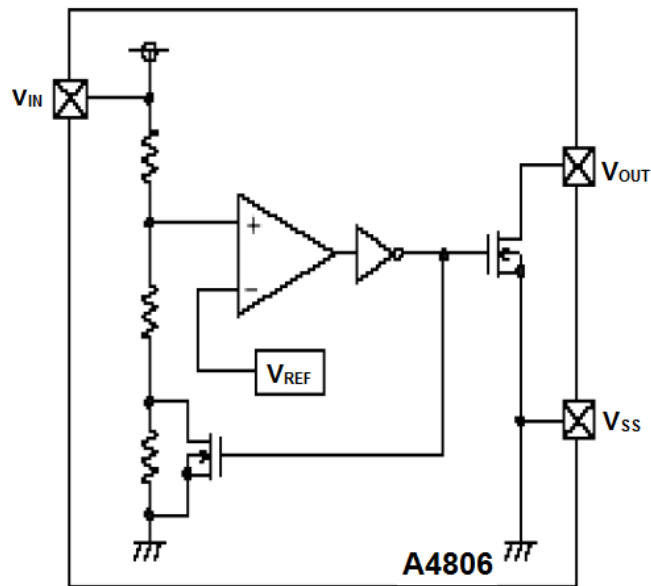

Nch Open-drain Output Products



DETAILED INFORMATION

Timing Chart

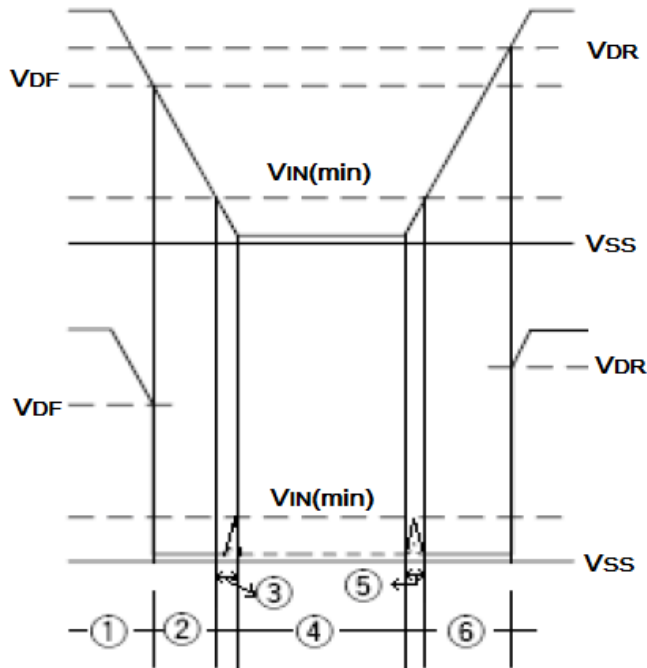

Operation

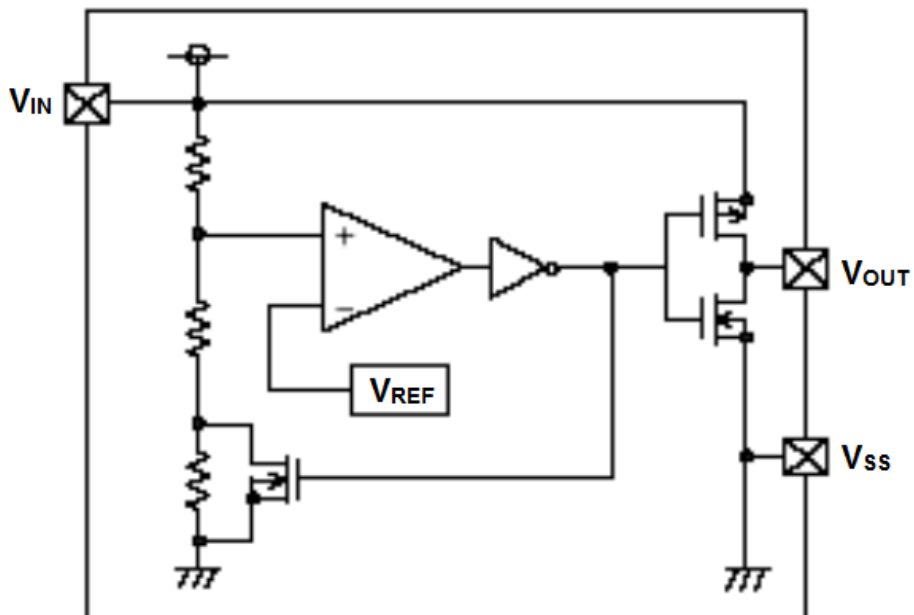



- 1-1. When the power supply voltage (V_{DD}) is higher than the release voltage (V_{DF}), the Nch transistor is OFF and the Pch transistor is ON to provide V_{DD} (high) at the output.
- 1-2. When the power supply voltage (V_{DD}) is lower than the release voltage (V_{DF}), the Nch transistor is ON and the Pch transistor is OFF to provide V_{SS} (low) at the output.
- 1-3. When the V_{DD} falls below the minimum operating voltage, the output becomes undefined, or goes to the V_{DD} when the output is pulled up to the V_{DD} .
- 1-4. The V_{SS} level appears when the V_{DD} is V_{SS} level.
- 1-5. The V_{SS} level appears when the V_{DD} rises above the minimum operating voltage. The V_{SS} level still appears even when the V_{DD} surpasses $-V_{DF}$, as long as it does not exceed the release voltage $+V_{DF}$.
- 1-6. When the V_{DD} rises above $+V_{DF}$ the Nch transistor becomes OFF and the Pch transistor becomes ON to provide V_{DD} level at the output.

Application Circuit Examples

Microcomputer Reset Circuits

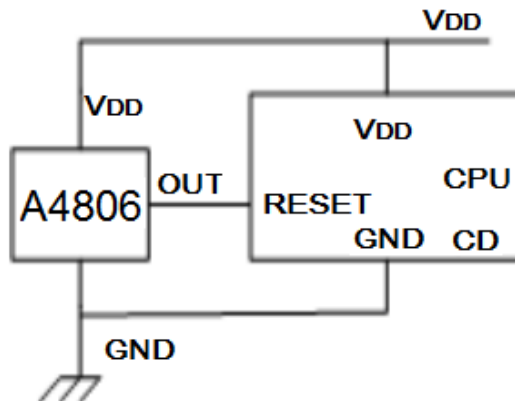

The same supply voltage with CPU (CMOS output)

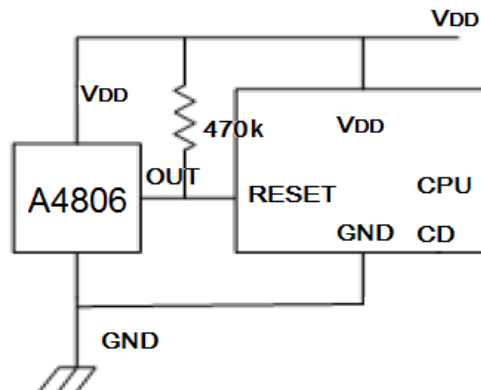

The same supply voltage with CPU (N_{CH} Open drain output)

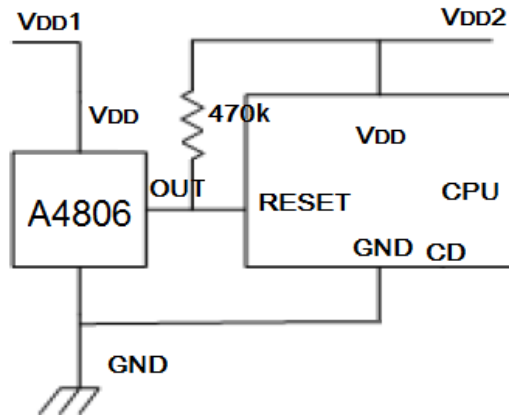

The different supply voltage with CPU (N_{CH} open drain output)

Power-on Reset Circuit

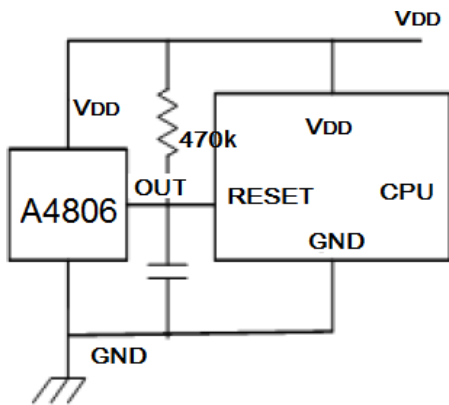

Nch Open Drain

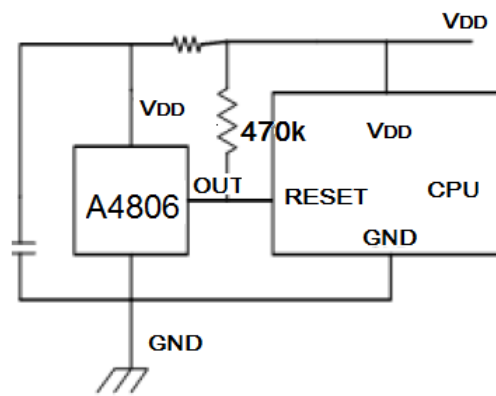

Nch Open Drain

Memory Back-up Circuit

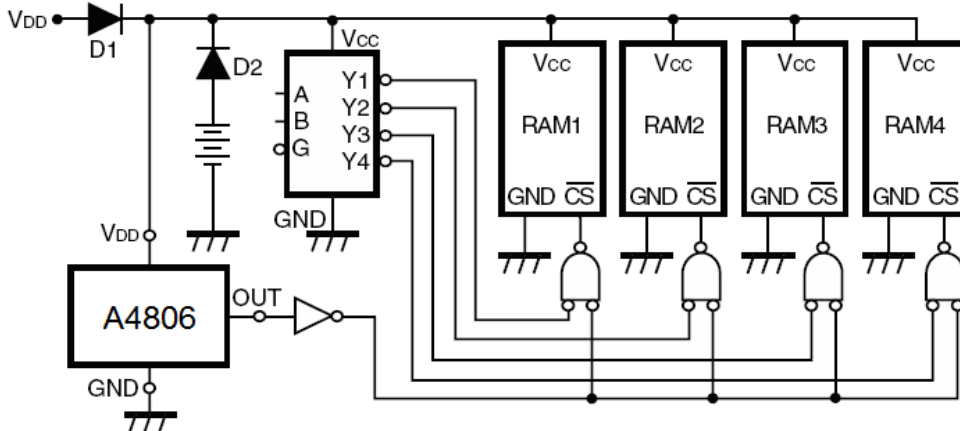



Power failure detectors

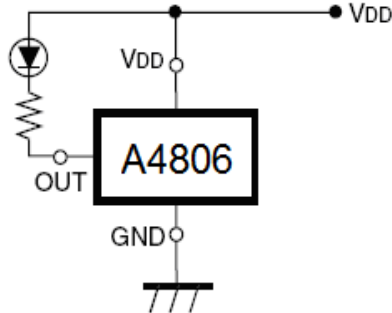

Overcharge protect circuit

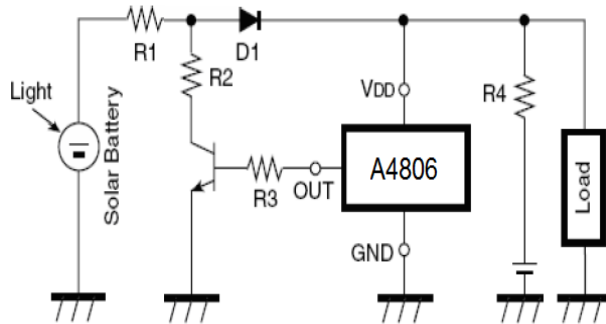

Window Comparator Circuit

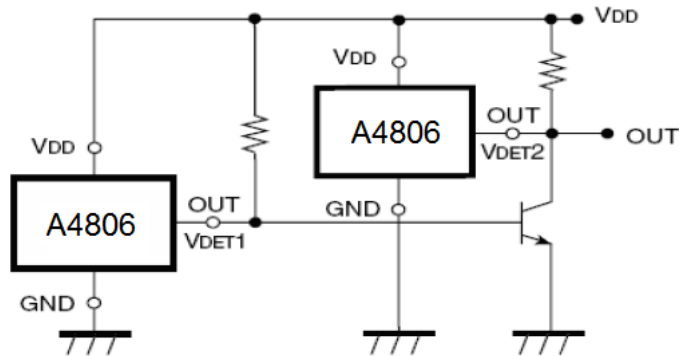

Detector Adjustable Circuit

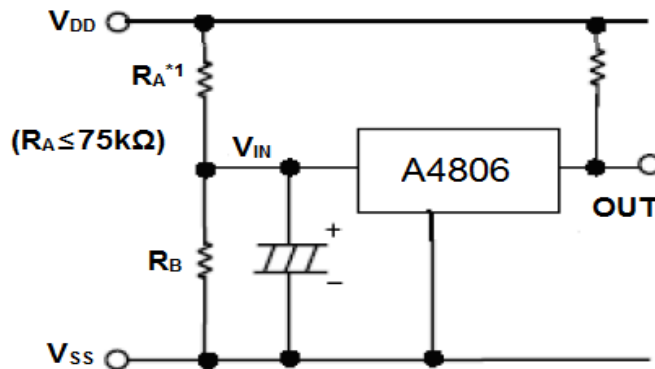



PACKAGE INFORMATION

Dimension in SOT-23 Package (Unit: mm)

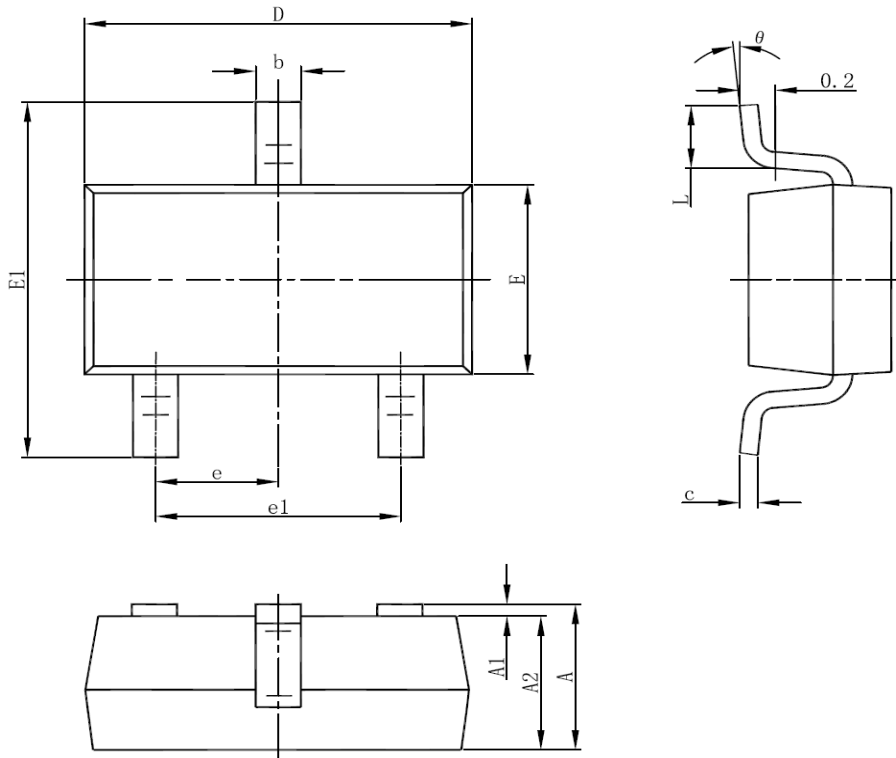

| Symbol | Millimeters | | Inches | |
|----------|-------------|-------|------------|-------|
| | Min. | Max. | Min. | Max. |
| A | 1.050 | 1.250 | 0.041 | 0.049 |
| A1 | 0.000 | 0.100 | 0.000 | 0.004 |
| A2 | 1.050 | 1.150 | 0.041 | 0.045 |
| b | 0.300 | 0.500 | 0.012 | 0.020 |
| c | 0.100 | 0.200 | 0.004 | 0.008 |
| D | 2.820 | 3.020 | 0.111 | 0.119 |
| E | 1.500 | 1.700 | 0.059 | 0.067 |
| E1 | 2.650 | 2.950 | 0.104 | 0.116 |
| e | 0.950(BSC) | | 0.037(BSC) | |
| e1 | 1.800 | 2.000 | 0.071 | 0.079 |
| L | 0.300 | 0.600 | 0.012 | 0.024 |
| θ | 0° | 8° | 0° | 8° |



IMPORTANT NOTICE

AiT Semiconductor Inc. (AiT) reserves the right to make changes to any its product, specifications, to discontinue any integrated circuit product or service without notice, and advises its customers to obtain the latest version of relevant information to verify, before placing orders, that the information being relied on is current.

AiT Semiconductor Inc.'s integrated circuit products are not designed, intended, authorized, or warranted to be suitable for use in life support applications, devices or systems or other critical applications. Use of AiT products in such applications is understood to be fully at the risk of the customer. As used herein may involve potential risks of death, personal injury, or server property, or environmental damage. In order to minimize risks associated with the customer's applications, the customer should provide adequate design and operating safeguards.

AiT Semiconductor Inc. assumes to no liability to customer product design or application support. AiT warrants the performance of its products of the specifications applicable at the time of sale.