

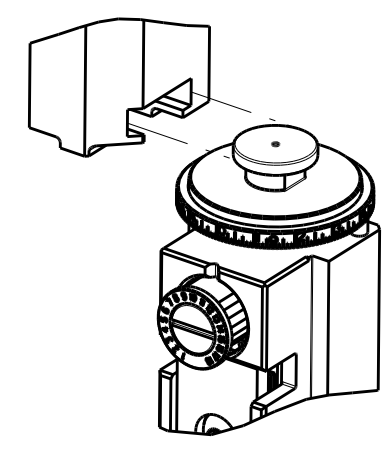



ATLANTIC VERSION TERMINATOR INTERFACE ADAPTER	PART NUMBER	REVISION	DESCRIPTION	FEED TYPE
	2150037-2	B	FINE CRIMP HEIGHT ADJUST	PNEUMATIC
	2150037-5	B	FINE CRIMP HEIGHT ADJUST	SERVO LATCH PLATE Δ 4
	2150037-6	B	NON-CRIMP HEIGHT ADJUST	Δ 4 SERVO LATCH PLATE Δ 1
	2150037-7	B	FINE CRIMP HEIGHT ADJUST	NONE
	7-2150037-7	A	CRIMP TOOLING KIT	-

APPLICATOR DATA		
CRIMP SIZE	TYPE	
WIRE 2.29 mm [.090]	F	
INSUL 3.56 mm [.140]	F	
APPLICATOR INSTRUCTIONS 408-10390 		

TERMINAL DATA: TE TERMINAL		TE CRIMP SPECIFICATION	
TERMINAL NAME: FASTIN-FASTON, .250 SERIES			
WIRE STRIP LENGTH		INSULATION DIAMETER RANGE	
5.21-5.97 mm [.205-.235 IN]		\varnothing 2.16-3.17 mm [.085-.125 IN]	
TERMINAL APPLICATION SPECIFICATION	(A) 114-2025		
TERMINALS APPLIED Δ 6			
TE TERMINAL (A) 60294-1	TE TERMINAL (A) 60294-2	TE TERMINAL (A) 62553-1	TE TERMINAL (A) 62553-3

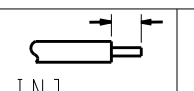
WIRE SIZE	CRIMP HEIGHT mm [INCH]	CRIMP HEIGHT REFERENCE SETTING Δ 9
18 AWG	1.35 +/- 0.05 [.053 +/- .002]	5.1
20 AWG	1.22 +/- 0.05 [.048 +/- .002]	6.7
22 AWG	1.17 +/- 0.05 [.046 +/- .002]	7.2

-  RECOMMENDED SPARE PARTS
- Δ 2 GREASE BEARING SURFACES LIGHTLY
- 3. LUBRICATE DAILY PER THE APPLICATOR INSTRUCTION SHEET SUPPLIED WITH THE APPLICATOR.
- Δ 4 APPLICATOR SPECIFIC DATA TO BE ENTERED INTO BLANK MEMORY CHIP AT ASSEMBLY. SEE BELOW FOR PART NUMBER:
 PNEUMATIC FEED WITH "SMART APPLICATOR" CONVERSION: 8-2150037-4
 SERVO FEED WITH "FINE CRIMP HEIGHT ADJUST": 8-2150037-5
 SERVO FEED WITH "NON-CRIMP HEIGHT ADJUST": 8-2150037-6
- 5. ADJUSTMENT OF THE STRIPPER MAY BE REQUIRED WHEN MOVING THE APPLICATOR BETWEEN BENCH AND LEADMAKER APPLICATIONS.
- Δ 6 APPLY PART NUMBER 1-23419-5 LOCTITE TO THREADS OF ITEMS 50, 62 & 242. FOR -6 ONLY APPLY PART NUMBER 1-23419-5 LOCTITE TO THREADS OF ITEMS 37, 50 & 242.
- Δ 7 GREASE THREADS, GROOVE AND O-RING ON ITEMS 35 & 252.
- Δ 8 MAGNET, ITEM 166 MUST BE ORIENTED CORRECTLY IN ORDER TO PROPERLY ACTUATE THE COUNTER.
- Δ 9 CRIMP HEIGHT REFERENCE SETTING WAS THE SETTING USED WHEN THE APPLICATOR WAS QUALIFIED AT THE FACTORY. ADJUSTMENT MAY BE NECESSARY WHEN RUNNING APPLICATOR IN THE FIELD.
- Δ 10 TERMINAL PITCH NOT COMPATIBLE WITH MECHANICAL FEED.
- Δ 11 WHEN ASSEMBLING -6 NON-CRIMP HEIGHT ADJUST APPLICATOR USE SHIM PACK 2119957-2 TO ALIGN APPLICATOR'S MAXIMUM WIRE CRIMP HEIGHT AT NORMAL TERMINATOR SHUT HEIGHT

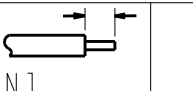
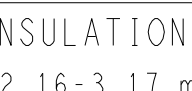
TERMINAL DATA: TE TERMINAL		TE CRIMP SPECIFICATION	
TERMINAL NAME: FASTIN-FASTON, .250 SERIES			
WIRE STRIP LENGTH		INSULATION DIAMETER RANGE	
5.21-5.97 mm [.205-.235 IN]		\varnothing 2.16-3.17 mm [.085-.125 IN]	
TERMINAL APPLICATION SPECIFICATION	(B) 114-20021		
TERMINALS APPLIED			
TE TERMINAL (B) 160691-1	TE TERMINAL (B) 160691-4	TE TERMINAL (B) 160691-7	
(B) 160691-2	(B) 160691-5	(B) 160645-1	
(B) 160691-3	(B) 160691-6	(B) 160645-2	

WIRE SIZE	CRIMP HEIGHT mm [INCH]	CRIMP HEIGHT REFERENCE SETTING Δ 9
18 AWG	1.32 +/- 0.05 [.052 +/- .002]	5.3
20 AWG	1.22 +/- 0.05 [.048 +/- .002]	6.7
22 AWG	1.14 +/- 0.05 [.045 +/- .002]	7.4

***WARNING**
 ON INSTALLATION, SET WIRE DISC, ITEM 40 TO LARGEST WIRE SIZE SETTING. USE OF SETTINGS BELOW MINIMUM REQUIRED CRIMP HEIGHT SETTING WILL CAUSE DAMAGE TO CRIMP TOOLING.

-77	-7	-6	-5	-2	PART NO	DESCRIPTION	ITEM NO
-	-	1	-	-	2119957-2	APPLICATOR SHIM PACK	260
-	1	-	1	1	8-21084-0	O-RING, .676 ID, .070 DIA. MAT.	252

ATLANTIC VERSION
 Shown on sheets 1 of 4 & 2 of 4
 (Pacific version shown on sheets 3 of 4 & 4 of 4)

SET UP GAUGE	LOC	DIST	REVISIONS			
2119599-2	A	66	REV	DATE	BY	APPV
			1	DEVELOPMENT	12JAN2012	YY SX
			2	UPDATED	11MAR2013	YY UG
			A	RELEASED	18APR2013	YY UG
			B	ECR-14-007234	15MAY2014	XZ TE

REV	DATE	BY	APPV	DESCRIPTION	ITEM NO		
-	-	-	-	1	2119640-1	PUSH ROD, AIR FEED	250
-	-	-	-	1	2079988-1	BUSHING, LCH5-12, MISUMI	249
-	-	-	-	1	2119641-1	FEED CAM, AIR FEED	248
-	1	-	1	1	2119798-1	DETENT PIN	247
-	1	-	1	1	1-22279-3	SPRING, COMPRESSION	246
-	-	1	-	-	2119759-1	RAM, AMP STYLE, END FEED, NON-ADJUST	245
-	1	1	1	1	2119082-9	CAM, SNAIL, INSULATION ADJUSTMENT	244
-	1	1	1	1	2079764-1	WASHER, WAVE SPRING, CREST-TO-CREST	243
-	1	1	1	1	2119083-1	RETAINER, INSULATION DIAL	242
-	-	2	2	-	2168400-7	SHCS, LOW HEAD, RoHS, M5 X 10	240
-	-	-	-	1	2063440-2	AIR FEED MODULE	238
-	-	1	1	-	2119740-2	TAG, IDENTIFICATION	213
-	-	REF	REF	-	1901697-1	FEED FINGER ASSEMBLY, EF	183
-	1	1	1	1	6-993111-6	PIN, SLOTTED SPRING 3.0 X 14.0	177
-	1	1	1	1	8-22280-7	SPRING, COMPRESSION	176
-	1	1	1	1	1752353-2	GUIDE PIN, HOLDDOWN	175
-	1	1	1	1	1901680-2	GUIDE PIN, HOLDDOWN	174
-	-	-	-	2	21045-3	RING, RETAIN, EXTERN, 3/16 CRESCENT	172
-	1	1	1	1	994969-1	MAGNET, RARE EARTH HIGH ENERGY	166
-	-	REF	REF	REF	994970-2	COUNTER, MAGNETIC	164
-	-	-	-	1	240638-1	SPRING, FEED FINGER	163
-	-	-	-	1	3-23627-7	PIN, RETAIN, GRVD, 3/16 X .854	137
-	-	REF	REF	-	SEE NOTE 4	MEMORY CHIP, PROGRAMMED	135
-	-	1	1	-	1633743-1	SERVO FEED LATCH ASM	133
-	1	1	1	1	455888-5	SPACER, CRIMPER	82
-	1	1	1	1	2119956-2	DOCUMENTATION PACKAGE	71
-	2	2	2	2	2-18032-2	SCR, SET, FLT POINT M3 X 10.0	70
-	1	-	-	1	2119740-1	TAG, IDENTIFICATION	67
-	2	2	2	2	2168078-1	SCREW, DRIVE, RH, RoHS, 2 x .188	66
-	1	1	1	1	1976052-1	HOLDDOWN, TERMINAL	65
-	1	-	1	1	2119793-1	LIMITER, ADJUSTMENT BOLT	63
-	3	-	3	3	992763-5	SCR, SET, SOC, CONE POINT, M3 X 4.0	62
-	1	1	1	1	2079383-4	SCR, BHSC, RoHS (M4 X 8)	60
-	4	4	4	4	2168400-4	SHCS, LOW HEAD, RoHS, M4 X 8	57
-	2	2	2	2	2168083-9	SCR, SKT HD CAP, RoHS, M4 X 20	56
-	2	2	2	2	5018030-2	NUT, HEX, REG, RoHS, M4	55
-	2	2	2	2	5018030-1	NUT, HEX, REG, RoHS, M3	54
-	2	2	2	2	986965-8	NUT, LOCK, HEX, TORQUE (M4)	53
-	1	1	1	1	1-5018030-0	NUT, HEX, REG, RoHS, M3.5	52
-	-	-	-	1	2119792-2	PAWL, EF, AIR	51
-	1	1	1	1	1752354-3	STANDOFF, HOLD-DOWN	50
-	-	-	-	1	18023-9	SCR, SKT HD CAP M4 X 6.0	49
-	1	1	1	1	2119655-5	APPLICATOR BASIC ASSEMBLY, EF	46
-	1	-	1	1	2119369-1	RAM, AMP STYLE, END FEED	44
-	1	1	1	1	2079383-7	SCR, BHSC, RoHS (M8 X 25)	41
-	1	-	1	1	2119645-1	DISC, NUMBERED FA WIRE ADJUSTMENT	40
-	1	-	1	1	2119957-1	APPLICATOR SHIM PACK	39
-	1	1	1	1	2119644-1	RAM WASHER, PRECISION	38
-	1	1	1	1	2119085-1	FA HEAD, ATLANTIC STYLE	37
-	1	-	1	1	2119092-1	BOLT, ADJUSTMENT	35
-	8	8	8	8	1-18028-2	WASHER, FLAT, REG M4	33
-	2	2	2	2	2168083-9	SCR, SKT HD CAP, RoHS, M4 X 20	31
-	2	2	2	2	1-2168083-0	SCR, SKT HD CAP, RoHS, M4 X 10	29
-	1	1	1	1	240639-1	STRIPPER (MACHINING)	27
-	2	2	2	2	1320906-1	STUD, THREADED	25
-	1	1	1	1	1752371-5	PLATE, STRIP GUIDE	24
-	2	2	2	2	2-22281-3	SPRING, COMPRESSION	22
-	1	1	1	1	1752373-4	DRAG	20
-	1	1	1	1	1-1901696-8	STRIP GUIDE, REAR	19
-	1	1	1	1	1-1901695-8	STRIP GUIDE, FRONT	18
-	4	4	4	4	1-2079383-1	SCR, BHSC, RoHS (M6 X 12)	17
-	1	1	1	1	5-240641-8	SPACER	16
-	1	1	1	1	1752360-1	SPACER, HOLD-DOWN	13
-	1	1	1	1	240644-1	PLATE, REAR SHEAR	11
-	-	-	-	-	-	-	10
-	1	1	1	1	690482-3	PLATE, FRONT SHEAR	9
-	1	1	1	1	1338673-6	ANVIL, COMBINATION	8
-	1	1	1	1	1-2217206-3	BLADE, SLUG	7
-	1	1	1	1	7-240641-4	SPACER	5
-	1	1	1	1	238009-1	BLOCK, FL CRIMPER SPACER	4
-	1	1	1	1	2-1633961-3	CRIMPER, INSULATION F PREMIUM	3
-	1	1	1	1	1-455888-2	SPACER, CRIMPER	2
-	1	1	1	1	1-456406-6	CRIMPER, WIRE PREMIUM	1

DIMENSIONS:		TOLERANCES UNLESS OTHERWISE SPECIFIED:		DRAWN BY		DATE		CHECKED BY		DATE	
mm	0 PLC ±.5	1 PLC ±.5	2 PLC ±.5	3 PLC ±.5	4 PLC ±.5	ANGLES ±.0001	FINISH	Y. YIN	12JAN2012	G. BAILEY	12JAN2012
MATERIAL								APPLICATOR SHIM PACK			
WEIGHT								260			
SCALE								1:1			
SHEET								1 OF 4			
REV								B			

LOC	DIST	REV	DATE	BY	APPV
A	66				
REVISIONS					
DESCRIPTION			DATE	BY	APPV
SEE SHEET 1					

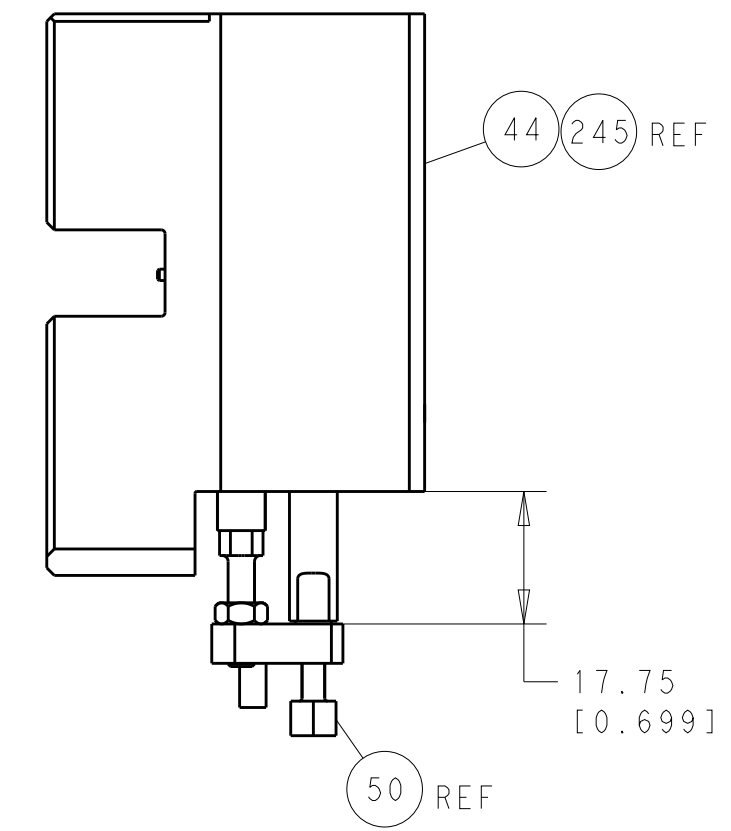

HOLDDOWN SET-UP

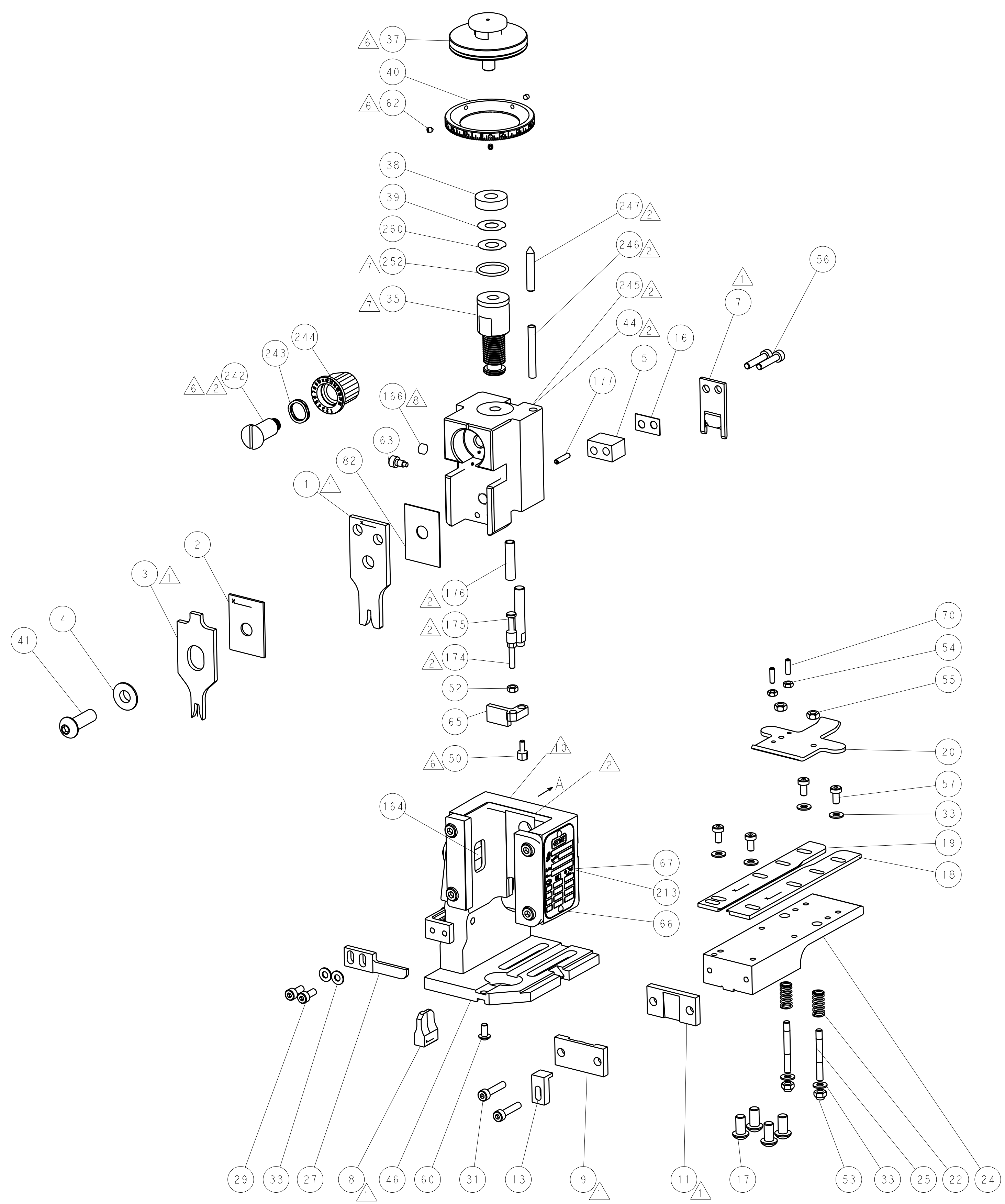

FEED TYPE

PNEUMATIC

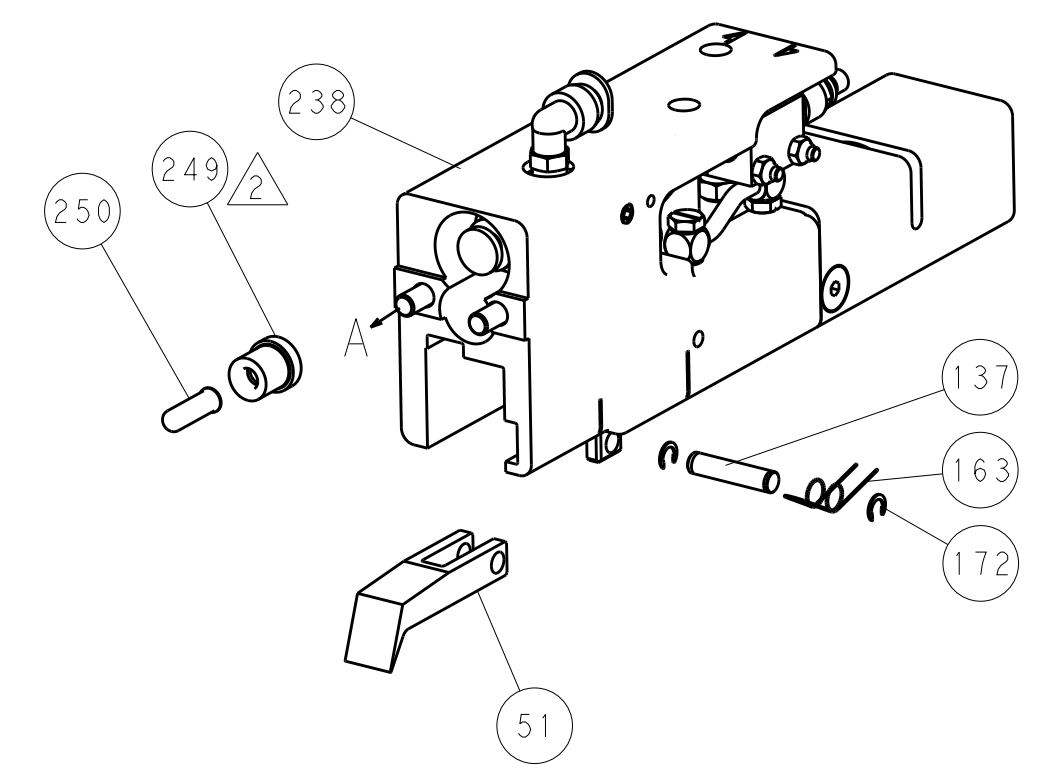

SERVO LATCH PLATE

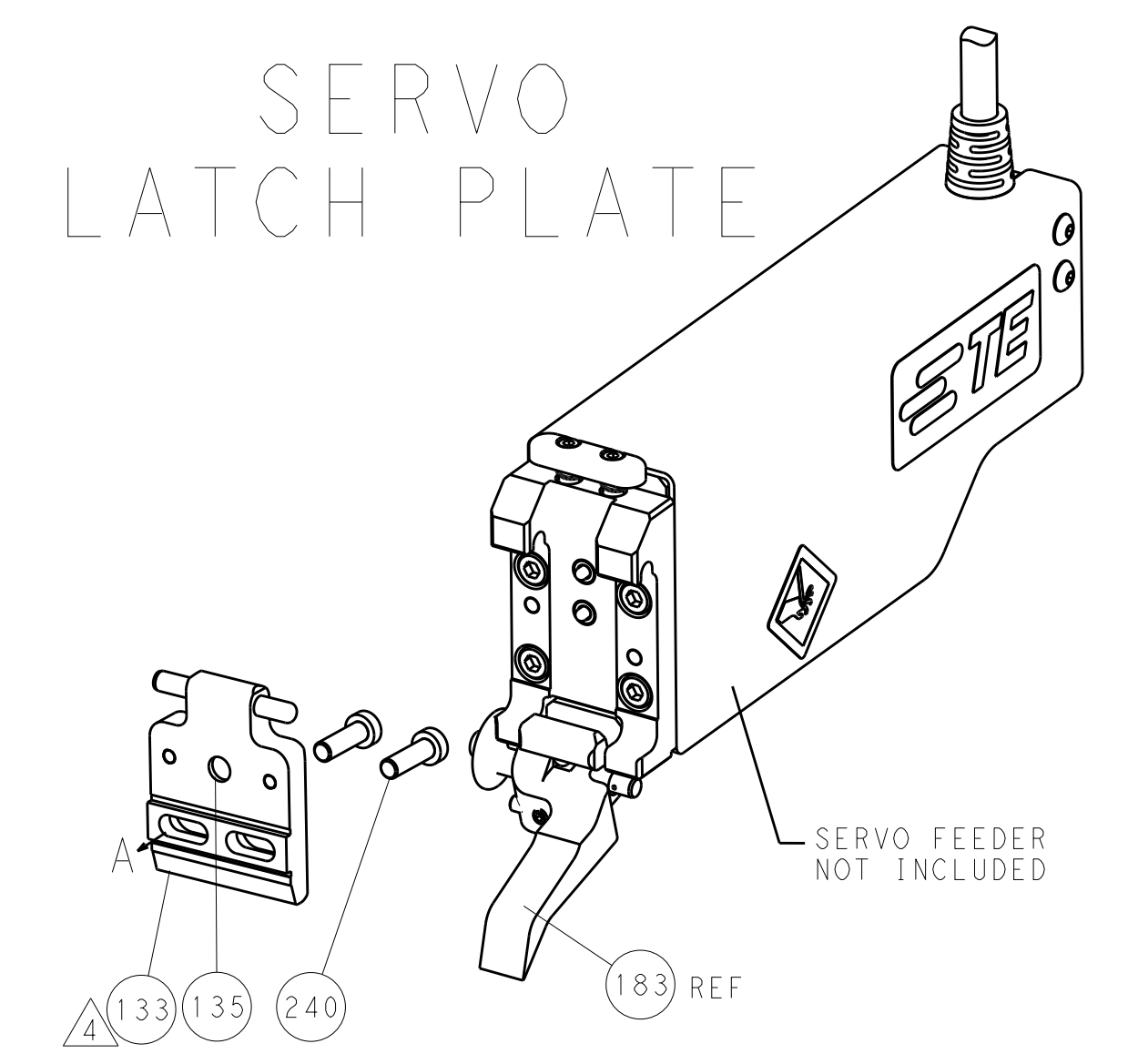

CAM POSITION

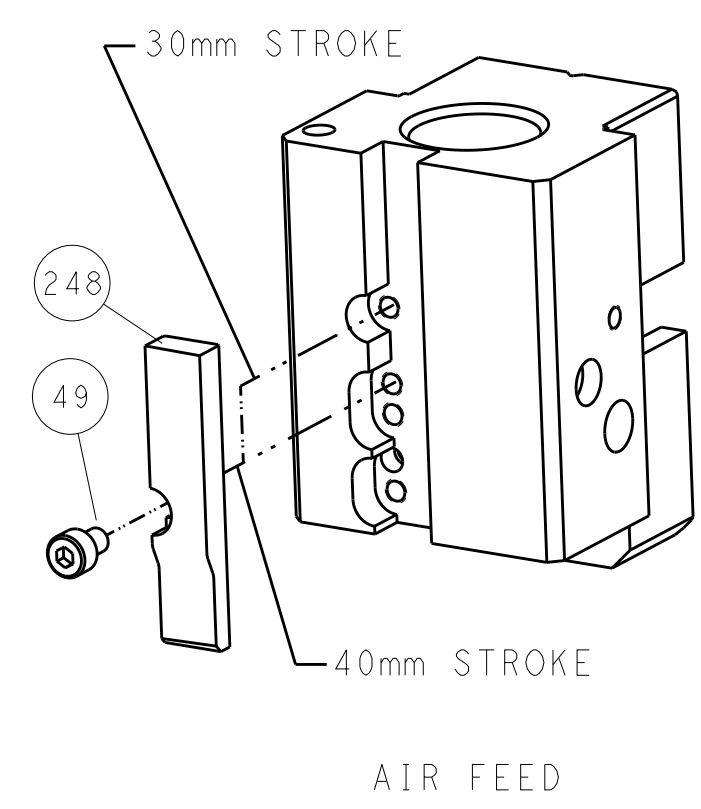

AIR FEED

ATLANTIC VERSION
 Shown on sheets 1 of 4 & 2 of 4
 (Pacific version shown on sheets 3 of 4 & 4 of 4)

DIMENSIONS:		TOLERANCES UNLESS OTHERWISE SPECIFIED:		DWG: Y. YIN 12JAN2012		TE Connectivity	
mm		0 PLC ±0.5		CHK: G. BAILEY 12JAN2012		Harrisburg, PA 17105-3608	
Ø		1 PLC ±0.13		APPV: S. XI 12JAN2012		NAME: Ocean End Feed Applicator	
H		3 PLC ±0.013		PRODUCT SPEC:		SIZE: CAGE CODE: DRAWING NO:	
ANGLES		4 PLC ±0.0001		APPLICATION SPEC:		RESTRICTED TO:	
FINISH:		5 PLC ±0.0001		WEIGHT:		A1 00779 ©=2150037	
MATERIAL:		6 PLC ±0.0001		Customer Accessible Production Drawing		SCALE: 1:1 SHEET 2 OF 4 REV B	

PACIFIC VERSION TERMINATOR INTERFACE ADAPTER	PART NUMBER	REVISION	DESCRIPTION	FEED TYPE	APPLICATOR STYLE CONVERSION CHART						
					CONVERT TO	PART NUMBERS REQUIRED					
	2-2150037-2	B	FINE CRIMP HEIGHT ADJUST	PNEUMATIC	-	-	-	-	-	-	
	2-2150037-5	B	FINE CRIMP HEIGHT ADJUST	SERVO LATCH PLATE Δ	SERVO LATCH PLATE	2119951-1	1901697-1	8-2150037-5	-	-	2168400-7 (QUANTITY 2)
					SMART APPLICATOR	2161326-1	-	8-2150037-4	-	-	-
	2-2150037-7	B	FINE CRIMP HEIGHT ADJUST	NONE	-	-	-	-	-	-	
7-2150037-7	A	CRIMP TOOLING KIT	-	-	-	-	-	-	-	-	

APPLICATOR DATA		
CRIMP SIZE	TYPE	
WIRE 2.29 mm (.090)	F	
INSUL 3.56 mm (.140)	F	
APPLICATOR INSTRUCTIONS 408-10390		

TERMINAL DATA: TE TERMINAL		TE CRIMP SPECIFICATION	
TERMINAL NAME: FASTIN-FASTON, .250 SERIES			
WIRE STRIP LENGTH		INSULATION DIAMETER RANGE	
5.21-5.97 mm (.205-.235 IN)		\varnothing 2.16-3.17 mm (.085-.125 IN)	
TERMINAL APPLICATION SPECIFICATION	(A) 114-2025	-	-
TERMINALS APPLIED Δ			
TE TERMINAL	TE TERMINAL	TE TERMINAL	TE TERMINAL
(A) 60294-1	(A) 60294-2	(A) 62553-1	(A) 62553-3

TERMINAL DATA: TE TERMINAL		TE CRIMP SPECIFICATION	
TERMINAL NAME: FASTIN-FASTON, .250 SERIES			
WIRE STRIP LENGTH		INSULATION DIAMETER RANGE	
5.21-5.97 mm (.205-.235 IN)		\varnothing 2.16-3.17 mm (.085-.125 IN)	
TERMINAL APPLICATION SPECIFICATION	(B) 114-20021	-	-
TERMINALS APPLIED			
TE TERMINAL	TE TERMINAL	TE TERMINAL	TE TERMINAL
(B) 160691-1	(B) 160691-4	(B) 160691-7	
(B) 160691-2	(B) 160691-5	(B) 160645-1	
(B) 160691-3	(B) 160691-6	(B) 160645-2	

WIRE SIZE	CRIMP HEIGHT mm [INCH]	CRIMP HEIGHT REFERENCE SETTING Δ
18 AWG	1.35 +/- 0.05 [.053 +/- .002]	5.1
20 AWG	1.22 +/- 0.05 [.048 +/- .002]	6.7
22 AWG	1.17 +/- 0.05 [.046 +/- .002]	7.2

WIRE SIZE	CRIMP HEIGHT mm [INCH]	CRIMP HEIGHT REFERENCE SETTING
18 AWG	1.32 +/- 0.05 [.052 +/- .002]	5.3
20 AWG	1.22 +/- 0.05 [.048 +/- .002]	6.7
22 AWG	1.14 +/- 0.05 [.045 +/- .002]	7.4

- RECOMMENDED SPARE PARTS
- GREASE BEARING SURFACES LIGHTLY
- 3. LUBRICATE DAILY PER THE APPLICATOR INSTRUCTION SHEET SUPPLIED WITH THE APPLICATOR.
- Δ APPLICATOR SPECIFIC DATA TO BE ENTERED INTO BLANK MEMORY CHIP AT ASSEMBLY. SEE BELOW FOR PART NUMBER:
 PNEUMATIC FEED WITH "SMART APPLICATOR" CONVERSION: 8-2150037-4
 SERVO FEED WITH "FINE CRIMP HEIGHT ADJUST": 8-2150037-5
- 5. ADJUSTMENT OF THE STRIPPER MAY BE REQUIRED WHEN MOVING THE APPLICATOR BETWEEN BENCH AND LEADMAKER APPLICATIONS.
- Δ APPLY PART NUMBER 1-23419-5 LOCTITE TO THREADS OF ITEMS 50, 62 & 242.
- Δ GREASE THREADS, GROOVE AND O-RING ON ITEMS 139 & 153.
- Δ MAGNET, ITEM 166 MUST BE ORIENTED CORRECTLY IN ORDER TO PROPERLY ACTUATE THE COUNTER.
- Δ CRIMP HEIGHT REFERENCE SETTING WAS THE SETTING USED WHEN THE APPLICATOR WAS QUALIFIED AT THE FACTORY. ADJUSTMENT MAY BE NECESSARY WHEN RUNNING APPLICATOR IN THE FIELD.
- Δ 10. TERMINAL PITCH NOT COMPATIBLE WITH MECHANICAL FEED.

***WARNING**
 ON INSTALLATION, SET WIRE DISC, ITEM 40 TO LARGEST WIRE SIZE SETTING. USE OF SETTINGS BELOW MINIMUM REQUIRED CRIMP HEIGHT SETTING WILL CAUSE DAMAGE TO CRIMP TOOLING.

PACIFIC VERSION
 Shown on sheets 3 of 4 & 4 of 4
 (Atlantic version shown on sheets 1 of 4 & 2 of 4)

SET UP GAUGE	LOC	DIST	REVISIONS			
2119599-2	A	66	REV	DATE	BY	APPV
			-	SEE SHEET 1	-	-

-	1	1	1	2119782-1	FINE ADJUST HEAD ASM, PACIFIC STYLE	251
-	-	-	1	2119640-1	PUSH ROD, AIR FEED	250
-	-	-	1	2079988-1	BUSHING, LCH5-12, MISUMI	249
-	1	1	1	1-22279-3	SPRING, COMPRESSION	246
-	1	1	1	2119082-9	CAM, SNAIL, INSULATION ADJUSTMENT	244
-	1	1	1	2079764-1	WASHER, WAVE SPRING, CREST-TO-CREST	243
-	1	1	1	2119083-1	RETAINER, INSULATION DIAL	242
-	-	2	-	2168400-7	SHCS, LOW HEAD, RoHS, M5 X 10	240
-	-	-	1	2063440-2	AIR FEED MODULE	238
-	-	1	-	2119740-2	TAG, IDENTIFICATION	213
-	4	4	4	2079383-9	SCR, BHSC, RoHS (M6 X 20)	186
-	-	REF	-	1901697-1	FEED FINGER ASSEMBLY, EF	183
-	1	1	1	6-993111-6	PIN, SLOTTED SPRING 3.0 X 14.0	177
-	1	1	1	8-22280-7	SPRING, COMPRESSION	176
-	1	1	1	1752353-2	GUIDE PIN, HOLDDOWN	175
-	1	1	1	1901680-2	GUIDE PIN, HOLDDOWN	174
-	-	-	2	21045-3	RING, RETAIN, EXTERN, 3/16 CRESCENT	172
-	1	1	1	994969-1	MAGNET, RARE EARTH HIGH ENERGY	166
-	REF	REF	REF	994970-2	COUNTER, MAGNETIC	164
-	-	-	1	240638-1	SPRING, FEED FINGER	163
-	1	1	1	8-21084-1	O-RING, .801 ID, .070 DIA. MAT.	153
-	-	-	1	2119641-2	FEED CAM, AIR FEED	152
-	1	1	1	2119798-2	DETENT PIN	145
-	1	1	1	2079383-8	SCR, BHSC, RoHS (M4 X 16)	144
-	1	1	1	2119655-6	APPLICATOR BASIC ASSEMBLY, EF	141
-	1	1	1	2119651-1	RAM, ASIAN STYLE, END FEED	140
-	1	1	1	2119092-2	BOLT, ADJUSTMENT	139
-	-	-	1	3-23627-7	PIN, RETAIN, GRVD, 3/16 X .854	137
-	-	REF	-	SEE NOTE 4	MEMORY CHIP, PROGRAMMED	135
-	-	1	-	1633743-1	SERVO FEED LATCH ASM	133
-	1	1	1	455888-5	SPACER, CRIMPER	82
-	1	1	1	2119956-2	DOCUMENTATION PACKAGE	71
-	2	2	2	2-18032-2	SCR, SET, FLT POINT M3 X 10.0	70
-	1	-	1	2119740-1	TAG, IDENTIFICATION	67
-	2	2	2	2168078-1	SCREW, DRIVE, RH, RoHS, 2 x .188	66
-	1	1	1	1976052-1	HOLDDOWN, TERMINAL	65
-	1	1	1	2119793-1	LIMITER, ADJUSTMENT BOLT	63
-	3	3	3	992763-5	SCR, SET, SOC, CONE POINT, M3 x 4.0	62
-	4	4	4	2168400-4	SHCS, LOW HEAD, RoHS, M4 X 8	57
-	2	2	2	2168083-9	SCR, SKT HD CAP, RoHS, M4 X 20	56
-	2	2	2	5018030-2	NUT, HEX, REG, RoHS, M4	55
-	2	2	2	5018030-1	NUT, HEX, REG, RoHS, M3	54
-	2	2	2	986965-8	NUT, LOCK, HEX, TORQUE (M4)	53
-	1	1	1	1-5018030-0	NUT, HEX, REG, RoHS, M3.5	52
-	-	-	1	2119792-2	PAWL, EF, AIR	51
-	1	1	1	1752354-3	STANDOFF, HOLD-DOWN	50
-	-	-	1	18023-9	SCR, SKT HD CAP M4 X 6.0	49
-	1	1	1	2079383-7	SCR, BHSC, RoHS (M8 X 25)	41
-	1	1	1	2119645-1	DISC, NUMBERED FA WIRE ADJUSTMENT	40
-	1	1	1	2119957-1	APPLICATOR SHIM PACK	39
-	1	1	1	2119644-1	RAM WASHER, PRECISION	38
-	8	8	8	1-18028-2	WASHER, FLAT, REG M4	33
-	2	2	2	2168083-9	SCR, SKT HD CAP, RoHS, M4 X 20	31
-	2	2	2	1-2168083-0	SCR, SKT HD CAP, RoHS, M4 X 10	29
-	1	1	1	240639-1	STRIPPER (MACHINING)	27
-	2	2	2	1320906-1	STUD, THREADED	25
-	1	1	1	1752371-5	PLATE, STRIP GUIDE	24
-	2	2	2	2-22281-3	SPRING, COMPRESSION	22
-	1	1	1	1752373-4	DRAG	20
-	1	1	1	1-1901696-8	STRIP GUIDE, REAR	19
-	1	1	1	1-1901695-8	STRIP GUIDE, FRONT	18
-	1	1	1	5-240641-8	SPACER	16
-	1	1	1	1752360-1	SPACER, HOLD-DOWN	13
-	1	1	1	240644-1	PLATE, REAR SHEAR	11
-	-	-	-	-	-	10
-	1	1	1	690482-3	PLATE, FRONT SHEAR	9
-	1	1	1	1338673-6	ANVIL, COMBINATION	8
-	1	1	1	1-2217206-3	BLADE, SLUG	7
-	1	1	1	7-240641-4	SPACER	5
-	1	1	1	238009-1	BLOCK, FL CRIMPER SPACER	4
-	1	1	1	2-1633961-3	CRIMPER, INSULATION F PREMIUM	3
-	1	1	1	1-455888-2	SPACER, CRIMPER	2
-	1	1	1	1-456406-6	CRIMPER, WIRE PREMIUM	1

DIMENSIONS:		TOLERANCES UNLESS OTHERWISE SPECIFIED:		DATE	BY	CHK	APPV	NAME	PRODUCT SPEC	APPLICATION SPEC	WEIGHT	SCALE	SHEET	OF	REV
mm	0 PLC ±.5	1 PLC ±0.5	2 PLC ±0.13	3 PLC ±0.013	4 PLC ±0.001	ANGLES ±.001	FINISH								
MATERIAL		FINISH		12JAN2012		12JAN2012		G. BAILEY		S. XI		12JAN2012		G. BAILEY	
Customer Accessible Production Drawing		SCALE 1:1		SHEET 3		OF 4		REV B		PART NO		DESCRIPTION		ITEM NO	

