

# Detector Switch Compact One-way Operation Type

SPVE Series



Applicable for use in compact digital devices. One of the smallest detector switches in the industry with a size of 3.4×3.0mm.

## Detector

Push

Slide

Rotary

Encoders

Power

Dual-in-line  
Package Type

TACT Switch™

Custom-  
Products

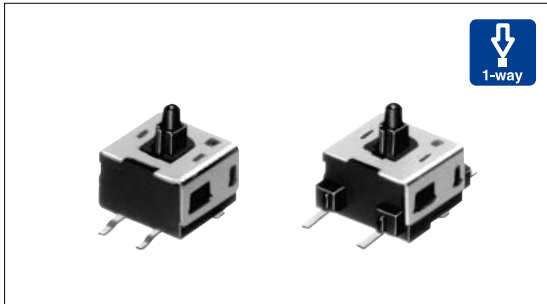

## Typical Specifications

Items		Specifications
Rating (max.) (min.) (Resistive load)		0.1A 30V DC/50μA 3V DC
Contact resistance (Initial /After operating life)		500m max./1 max.
Operating force		0.3N max.
Operating life	Without load	50,000cycles
	With load	50,000cycles( 0.1A 30V DC )

## Product Line

Poles	Positions	Terminal type	Slider height (mm)	ON start position (mm)	Total travel (mm)	Mounting method	Location lug	Minimum order unit (pcs)	Product No.	Drawing No.			
1	1	For PC board (Reflow)	h=3.8	h <sub>1</sub> =3.5	h <sub>2</sub> =2.5	Standard	Without	22,400	SPVE110100	1			
			h=4.1	h <sub>1</sub> =3.8	h <sub>2</sub> =2.9		With		SPVE110600				
			h=4.8	h <sub>1</sub> =4.5	h <sub>2</sub> =3.6		Without		SPVE110401				
			h=5.2	h <sub>1</sub> =4.9	h <sub>2</sub> =4.0		With		SPVE110801				
			h=5.5	h <sub>1</sub> =5.2	h <sub>2</sub> =4.3	With	16,000	SPVE110200					
			3.3	3.0	2.0			Low-profile	22,400		SPVE110900		
												SPVE111300	
												SPVE111200	
								SPVE210100	2				

## Taping Specifications (Taping Packaging)

Reel Size Unit:mm

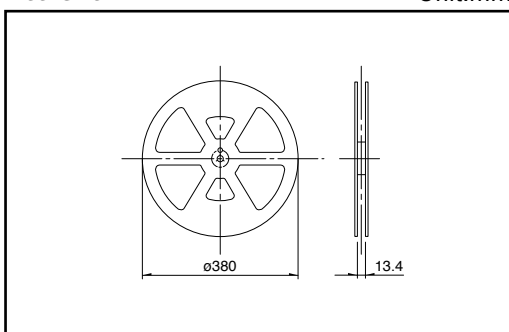

Series		Number of packages ( pcs. )			Tape width ( mm )
		1 reel	1 case /Japan	1 case /export packing	
Standard	h=3.8	2,800	5,600	22,400	12
	h=4.1				
	h=4.8	2,200	4,400	17,600	
	h=5.2	2,000	4,000	16,000	
	h=5.5				
Low-profile	h=3.3	2,800	5,600	22,400	

## Notes

- Standard type dimensions indicate "with location lug" version.
- Products other than those listed in the above chart are also available. Please contact us for details.
- Please place purchase orders per minimum order unit(integer).

Detector

Push

Slide

Rotary

Encoders

Power

Dual-in-line  
Package Type

TACT Switch™

Custom-  
Products

Dimensions		Unit:mm
No.	Style	PC board mounting hole and land dimensions (Viewed from direction A)
1	<b>Standard type</b> 	<b>Reflow pattern</b> 
	<b>Low-profile type</b> 	

















Terminal Layout (Viewed from Direction A)

Standard type	Low-profile type

Circuit Diagram

Standard type	Low-profile type

## List of Varieties ( General-purpose Type )

Series	General-purpose Type								
	SPPB	SPVE	SPPW8	SPVM	SPVR	SPVF	SSCU	SSCT	
Photo									
Operation type	 								
Operating temperature range	-40 to +85		-10 to +60		-40 to +85		-40 to +85		
Rating (max.) (Resistive load)	0.1A 30V DC			1mA 5V DC			0.1A 12V DC		
Rating (min.) (Resistive load)	50μA 3V DC		100μA 3V DC	50μA 3V DC	100μA 3V DC	50μA 3V DC			
Electrical performance	Initial contact resistance	1 max.	500m max.	1 max.	2 max.	3 max.	500m max.	70m max. 20m max.	
	Insulation resistance	100M min. 100V DC						100M min. 250V DC	
	Voltage proof	100V AC for 1 minute						250V AC for 1 minute	
Mechanical performance	Terminal strength	3N for 1 minute	0.5N for 1 minute	3N for 1 minute	1N for 1 minute	0.5N for 1 minute	3N for 30s	3N for 1 minute	
	Actuator strength	10N	5N	10N	5N	2N	1N	5N 10N	
Durability	Operating life without Load	50,000cycles 2 max.	50,000cycles 1 max.	100,000cycles 2 max.	50,000cycles 5 max.		100,000cycles 1 max.	10,000cycles 100m max. 40m max.	
	Operating life with Load	(0.1A 30V DC) 50,000cycles 2 max.	(0.1A 30V DC) 50,000cycles 1 max.	(0.1A 30V DC) 100,000cycles 2 max.	(1mA 5V DC) 50,000cycles 5 max.		(1mA 5V DC) 100,000cycles 1 max.	(0.1A 12V DC) 10,000cycles 150m max. 60m max.	
Environmental performance	Cold	-20 ± 2 for 96h					-40 ± 2 for 96h	-20 ± 2 for 96h	
	Dry heat	85 ± 2 for 96h							
	Damp heat	40 ± 2 , 90 to 95%RH for 96h							
Dimensions (mm)	W	6.3	3.4	5	2.8	3.6	9	11 12.5	
	D	3		4	3.5	4.2	3.5	5.8 5	
	H	4.9	2.3		1.5	1.2	4.5	7 11.5	
Soldering	Manual soldering	300 ± 5 , 5s max.		350 ± 5 , 3s max.			300 ± 10 , 3 ± 1s	350 ± 5 , 3s max.	
	Dip soldering	260 ± 5 , 5 ± 1s		255 ± 5 , 5 ± 1s		245 ± 5 , 5 ± 1s		260 ± 5 , 5 ± 1s	
	Reflow soldering	Please see P.79							
Number of poles	1					1.2	1		
Operation force	0.35N max.	0.3N max.		0.4N max.	0.35N max.	0.3N max.	0.5N max.	0.7 ± 0.3N	
Page	28	34	36	38	40	41	44	45	

Detector

Push

Slide

Rotary

Encoders

Power

Dual-in-line Package Type

TACT Switch™

Custom-Products

Detector Switches Soldering Conditions .....79

Detector Switches Cautions .....80

## Soldering Conditions

### Example of Reflow Soldering Condition

1. Heating method: Double heating method with infrared heater.
2. Temperature measurement: Thermocouple 0.1 to 0.2 CA (K) or CC (T) at soldering portion (copper foil surface). A heat resisting tape should be used for fixed measurement.
3. Temperature profile

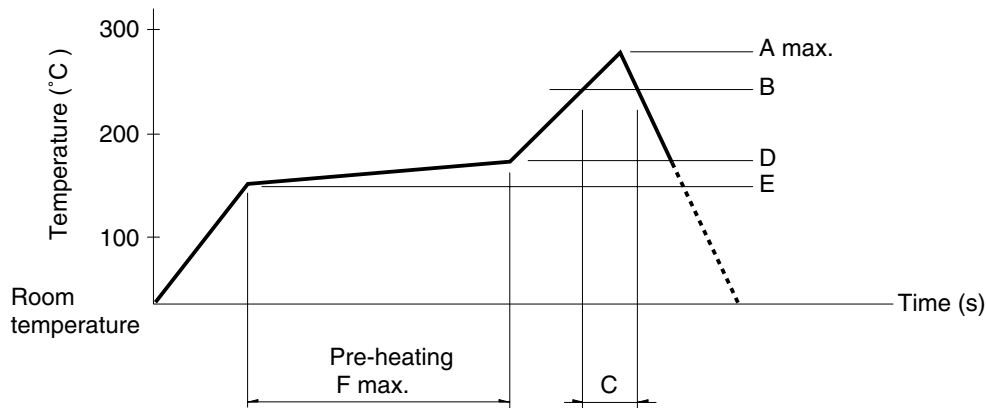

**Detector**

Push

Slide

Rotary

Encoders

Power

Dual-in-line  
Package Type

TACT Switch™

Custom-  
Products

Series( Reflow type )	A( ) 3s max.	B( )	C(s)	D( )	E( )	F(s)
SPPB	250	230	40			
SPPW8		200	20			
SPVE	260	230	40	180	150	120
SPVG						
SPVL						
SPVM						
SPVN						
SPVP						
SPVR						
SPVS						
SSCM						
SPPY5						

**Notes**

1. The condition mentioned above is the temperature on the mounting surface of a PC board. There are cases where the PC board's temperature greatly differs from that of the switch, depending on the PC board's material, size, thickness, etc. The above-stated conditions shall also apply to switch surface temperatures.
2. Soldering conditions differ depending on reflow soldering machines. Prior verification of soldering condition is highly recommended.