

## MAX14748 Evaluation Kit

Evaluates: MAX14748

### General Description

The MAX14748 evaluation kit (EV kit) is a fully assembled and tested circuit for evaluating the MAX14748 USB Type-C charger. Refer to the MAX14748 IC data sheet for detailed information regarding the operation and features of the devices.

For additional information, please refer to the MAX14748 user guide.

### Features

- RoHS Compliant
- Proven PCB Layout
- Full Assembled and Tested
- I<sup>2</sup>C Serial Interface

### Quick Start

#### Required Equipment

- MAX14748 EV Kit board
- Munich 2 adapter board (USB2PMB2#)
- Windows XP®, Windows Vista®, Windows® 7, or Windows 10 PC with one available USB port
- One USB A to USB Micro-B cable
- USB Type-C charger and Type-C cable
- 2s Li+ battery pack

*Windows, Windows Vista, and Windows XP are registered trademarks of Microsoft.*

### Procedure

The EV kit is fully assembled and tested. Follow the steps below to verify board operation:

- 1) Visit <https://www.maximintegrated.com> to download the latest version of the EV kit software, MAX14748EVKitSetupVxxx.ZIP located on the MAX14748 EV kit web page. Download the EV kit software to a temporary folder and uncompress the ZIP file.
- 2) Install the EV kit software on your computer by running the MAX20332EVKitSetupVxxx.EXE program inside the temporary folder.
- 3) Verify that all jumpers are in their default positions, as shown in Table 1.
- 4) Connect the USBPMB2 adapter board to J5 PMOD connector on the MAX14748 EV Kit.
- 5) Connect the USB A-micro-B cable between the PC and the X1 port on the USB2PMB2. USB driver should be installed automatically.
- 6) Attach a charged battery pack to J6 or connect the USB Type-C charger to J1.
- 7) Run the previously installed MAX14748 EVKit Tool software. The EV kit software main window appears, as shown in Figure 1.
- 8) If connection is successfully established, the status bar at the bottom displays “Connected”.
- 9) The EV kit is now ready for additional evaluation.

**Ordering Information appears at end of data sheet.**

## Detailed Description of Hardware

### Jumper Descriptions

[Table 1](#) details the functions of the configurable jumper headers on the EV kit board. The headers are standard 0.1in spacing, 0.025in posts. Settings in [Table 1](#) marked with an asterisk (“\*”) indicate default placements.

### Digital Inputs and Outputs

The bias for the logic inputs and open-drain indicators is provided from the VMC pin of J4 connector. Install jumper between 2-3 pins of JU5 to use VMC for the VIO supply.

The CDIR, SYSOK, and  $\overline{\text{INT}}$  open-drain outputs use VIO supply for their respective pullup voltages. Jumpers JU1, JU3, JU4 connect the indicator LED1, LED3, and LED4 to these open-drain flags.

Based on the Type-C state machine output, BVCEN push-pull output controls the external load switch Q2. When BVCEN is high, Q2 connects VCONN to the external supply source applied at TP19.

$\overline{\text{FLTIN}}$  and FSUS are digital inputs set by JU7 and JU8.  $\overline{\text{FLTIN}}$  is the charger fault input. If pulled low,  $\overline{\text{FLTIN}}$  forces the charger into a fault state. FSUS is the force suspend input. If pulled high, it forces the input current limit to 0A.

**Table 1. Jumper Functions and Default Settings**

JUMPER	SETTINGS	DESCRIPTION
JU1 $\overline{\text{INT}}$	Open	Disconnect $\overline{\text{INT}}$ output from indicator LED1
	Closed*	Connect $\overline{\text{INT}}$ output to indicator LED1
JU2 CHGIN	Open	Disconnect CHGIN from Q1 NVP PFET
	1-2*, 3-4*	Connect CHGIN to Q1 NVP PFET
JU3 CDIR	Open	Disconnect CDIR output from indicator LED3
	Closed*	Connect CDIR output to indicator LED3
JU4 SYSOK	Open	Disconnect SYSOK output from indicator LED4.
	Closed*	Connect SYSOK output to indicator LED4
JU5 VIO	1-2	Connect VIO to pin 1 of JU5
	2-3*	Connect VIO to VMC of J5
JU6 SET	1-2	Connect SET to R12 (10k)
	2-3*	Connect SET to R13 (Potentiometer)
JU7 $\overline{\text{FLTIN}}$	Open	Disconnect $\overline{\text{FLTIN}}$ from R11 and PB1
	Closed*	Connect $\overline{\text{FLTIN}}$ to R11 and PB1
JU8 FSUS	Open	Disconnect FSUS from VIO
	Closed*	Connect FSUS to VIO
JU9 SCL	Open	Disconnect SCL from R19 (Pullup)
	Closed*	Connect SCL to R19 (Pullup)
JU10 VTPU	Open	Disconnect VTPU from $V_{\text{CCINT}}$
	Closed*	Connect VTPU to $V_{\text{CCINT}}$
JU11 TPU	Open	Disconnect THM from R15
	Closed*	Connect THM to TPU through R15
JU12 THM	Open	Disconnect THM from R16 (Potentiometer)
	Closed*	Connect THM to R16 (Potentiometer)
JU13 SDA	Open	Disconnect SDA from R18 (Pullup)
	Closed*	Connect SDA to R18 (Pullup)

\*Default position.

**USB Interface**

The MAX14748 provides an integrated USB2.0 full-speed interface (12Mbps). This interface is accessed through the USB Type-C connector J1 and USB Type-A connector J3\_USB\_A. VBUS\_C of J1 is also a power source for U1.

**I/O Interface Connector**

The EV kit allows accessing the I<sup>2</sup>C interface of the MAX14748 through the J5 PMOD connector. Please refer to [Table 2](#) for the connectors' pin description.

**Table 2. PMOD Connector J5**

PIN	MAX14748	DESCRIPTION
1	N.C.	Not Connected
2	N.C.	Not Connected
3	SCL	I <sup>2</sup> C Serial Clock Input
4	SDA	I <sup>2</sup> C Serial Data Input/Output
5	GND	Ground
6	VMC	3.3V Digital Input/Output Supply
7	N.C.	Not Connected
8	N.C.	Not Connected
9	N.C.	Not Connected
10	N.C.	Not Connected
11	GND	Ground
12	VMC	3.3V Digital Input/Output Supply

**Ordering Information**

PART	TYPE
MAX14748EVKIT#	EV Kit

#Denotes RoHS compliant.

MAX14748 EV Kit Bill of Materials

ITEM	REF_DES	QTY	MFG PART #	MANUFACTURER	VALUE	DESCRIPTION
1	C1, C15-C19	6	GCJ188R71H104KA12; GCM188R71H104K; CGA3E2X7R1H104K080AA	MURATA; TDK	0.1UF	CAPACITOR; SMT (0603); CERAMIC CHIP; 0.1UF; 50V; TOL=10%; TG=-55 DEGC TO +125 DEGC; TC=X7R; AUTO
2	C2	1	C1608COG1H392K080AA	TDK	3900PF	CAP;SMT (0603);3900PF;10%;50V;COG;CERAMIC CHIP
3	C3, C9, C11, C12	4	CL10B105KP8NFN	SAMSUNG ELECTRONICS	1UF	CAPACITOR; SMT (0603); CERAMIC; 1UF; 10V; TOL=10%; TG=-55 DEGC TO +125 DEGC; TC=X7R
4	C4-C7	4	GRM32ER71E226KE15; CL32B226KAJNFN; CL32B226KAJNNW	MURATA; SAMSUNG ELECTRONICS	22UF	CAPACITOR; SMT (1210); CERAMIC CHIP; 22UF; 25V; TOL=10%; TG=-55 DEGC TO +125 DEGC; TC=X7R
5	C10, C13	2	CGA4J3X7R1H105K125AB	TDK	1UF	CAPACITOR; SMT (0805); CERAMIC CHIP; 1UF; 50V; TOL=10%; TG=-55 DEGC TO +125 DEGC; TC=X7R; AUTO
6	J1	1	DX07S024JJ3	JAE ELECTRONIC INDUSTRY	DX07S024JJ3	CONNECTOR; FEMALE; SMT; USB TYPE-C CONNECTOR; DX07 SERIES RECEPTACLE; RIGHT ANGLE; 24PINS
7	J3	1	1903814-1	TE CONNECTIVITY	1903814-1	CONNECTOR; FEMALE; THROUGH HOLE; INDUSTRIAL USB RECEPTACLE ASSEMBLY; RIGHT ANGLE; 1 ROW; STRAIGHT; 4PINS;
8	J5	1	TSW-106-08-5-D-RA	SAMTEC	TSW-106-08-5-D-RA	CONNECTOR; THROUGH HOLE; DOUBLE ROW; RIGHT ANGLE; 12PINS;
9	J6, JU1, JU3, JU4, JU7-JU13	11	PBC02SAAN	SULLINS ELECTRONICS CORP.	PBC02SAAN	EVKIT PART-CONNECTOR; MALE; THROUGH HOLE; BREAKAWAY; STRAIGHT; 2PINS; -65 DEGC TO +125 DEGC;
10	JU2	1	PBC02DAAN	SULLINS ELECTRONIC CORP.	PBC02DAAN	CONNECTOR; MALE; THROUGH HOLE; BREAKAWAY; STRAIGHT; 4PINS
11	JU5, JU6	2	PEC03SAAN	SULLINS ELECTRONICS CORP.	PEC03SAAN	EVKIT PART-CONNECTOR; MALE; THROUGH HOLE; BREAKAWAY; STRAIGHT; 3PINS; -65 DEGC TO +125 DEGC;
12	L1	1	XFL4020-222ME	COILCRAFT	2.2UH	INDUCTOR; SMT; METAL COMPOSITE CORE; 2.2UH; TOL=+/-20%; 8A; -40 DEGC TO +125 DEGC
13	LED1-LED5	5	LG L29K-G2J1-24	OSRAM	LG L29K-G2J1-24	DIODE; LED; SMT (0603); Vf=1.7V; If(test)=0.002A; -40 DEGC TO +100 DEGC
14	PB1	1	1825910-6	TE CONNECTIVITY	1825910-6	SWITCH; SPST; THROUGH HOLE; 24V; 0.05A; TACTILE SWITCH; RCOIL=0 OHM; RINSULATION=100M OHM; TE CONNECTIVITY
15	Q1	1	RRL035P03	ROHM	RRL035P03	TRAN; POWER MOSFET; PCH; TUMT6; PD-(1.0W); I-(-3.5V); V-(-30V)
16	Q2	1	NX5P2924BUK	NXP	NX5P2924BUK	IC; SWTC; LOGIC CONTROLLED HIGH-SIDE POWER SWITCH; WLCSP6

**MAX14748 EV Kit Bill of Materials (continued)**

ITEM	REF_DES	QTY	MFG PART #	MANUFACTURER	VALUE	DESCRIPTION
17	R1-R4, R11, R18, R19	7	TNPW06033K92BE	VISHAY DALE	3.92K	RESISTOR, 0603, 3.92K OHM, 0.1%, 25PPM, 0.10W, THICK FILM
18	R5-R8, R17	5	CRCW0603499RFK; RK73H1J4990FT; ERJ-3EKF4990V; RC1608F4990	KOA; VISHAY; PANASONIC; SAMSUNG	499	RESISTOR; 0603; 499 OHM; 1%; 100PPM; 0.10W; THICK FILM
19	R9, R20	2	TNPW06031K00BE; RG1608P-102-B-T5	VISHAY DALE/SUSUMU CO LTD.	1K	RESISTOR; 0603; 1K OHM; 0.1%; 25PPM; 0.10W; THICK FILM
20	R12, R15	2	CRCW060310K0JN; ERJ-3GEYJ103V	VISHAY DALE; PANASONIC	10K	RESISTOR; 0603; 10K OHM; 5%; 200PPM; 0.10W; THICK FILM
21	R13	1	64WR500KLF	TT ELECTRONICS	500K	RESISTOR; THROUGH HOLE; 64 SERIES; 500K OHM; 10%; 100PPM; 0.25W
22	R14	1	CRCW06031003FK; ERJ-3EKF1003	VISHAY DALE/PANASONIC	100K	RESISTOR; 0603; 100K; 1%; 100PPM; 0.10W; THICK FILM
23	R16	1	PV37W104C01B00	BOURNS	100K	RESISTOR; THROUGH HOLE; PV37 SERIES; 100K OHM; 10%; 150PPM; 0.25W
24	SU1, SU3-SU13, SU2A, SU2B	14	SX1100-B	KYCON	SX1100-B	TEST POINT; JUMPER; STR; TOTAL LENGTH=0.24IN; BLACK; INSULATION=PBT;PHOSPHOR BRONZE CONTACT=GOLD PLATED
25	TP1-TP4, TP6	5	5010	KEYSTONE	N/A	TESTPOINT WITH 1.80MM HOLE DIA, RED, MULTIPURPOSE;
26	TP5, TP7, TP8, TP18-TP20	6	5003	KEYSTONE	N/A	TEST POINT; PIN DIA=0.1IN; TOTAL LENGTH=0.3IN; BOARD HOLE=0.04IN; ORANGE; PHOSPHOR BRONZE WIRE SILVER PLATE FINISH;
27	TP9-TP15	7	5011	KEYSTONE	N/A	TEST POINT; PIN DIA=0.125IN; TOTAL LENGTH=0.445IN; BOARD HOLE=0.063IN; BLACK; PHOSPHOR BRONZE WIRE SILVER PLATE FINISH;
28	TP16, TP17	2	5004	KEYSTONE	N/A	TEST POINT; PIN DIA=0.1IN; TOTAL LENGTH=0.3IN; BOARD HOLE=0.04IN; YELLOW; PHOSPHOR BRONZE WIRE SILVER PLATE FINISH;
29	U1	1	MAX14748B	MAXIM	MAX14748B	EVKIT PART-IC; USB TYPE-C CHARGER; WLP54; PKG CODE: W542C3+1; PKG OUTLINE NO.: 21-100122
30	U2, U3	2	NC7WZ07P6X	FAIRCHILD SEMICONDUCTOR	NC7WZ07P6X	IC; BUF; TINY LOGIC ULTRA-HIGH SPEED DUAL BUFFER; SC70-6
31	PCB	1	MAX	MAXIM	PCB	PCB:MAX
TOTAL		100				

MAX14748 EV Kit Schematics

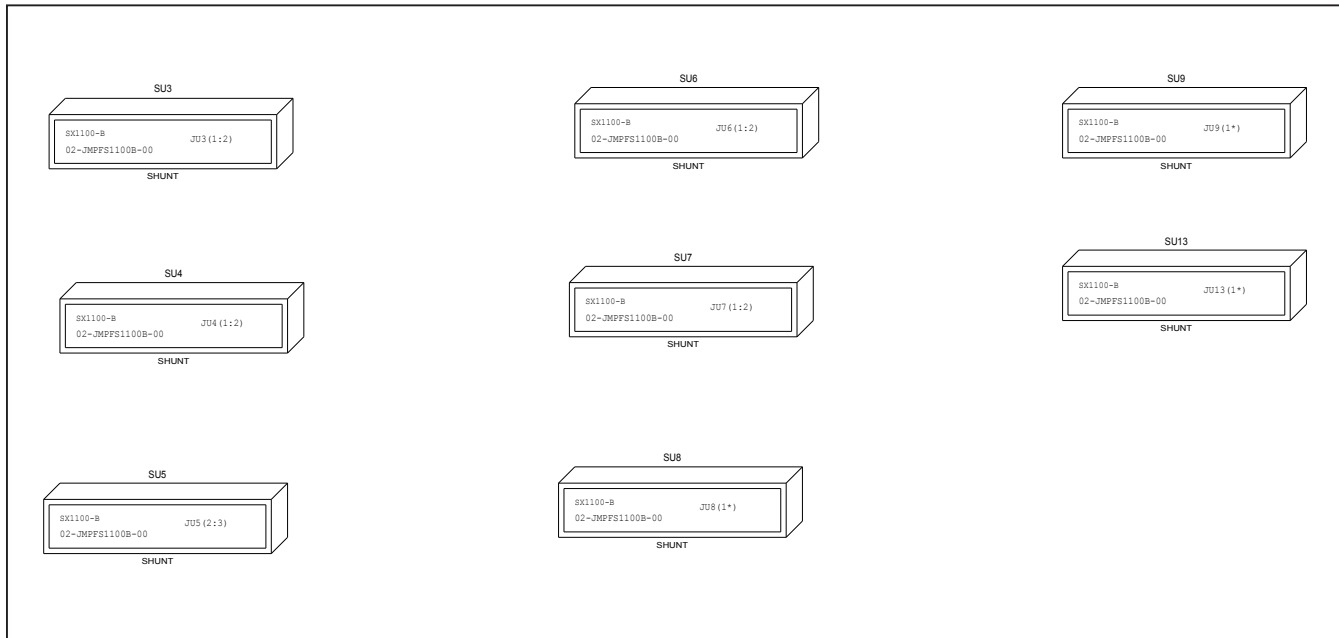



MAX14748 EV Kit PCB Layout Diagrams

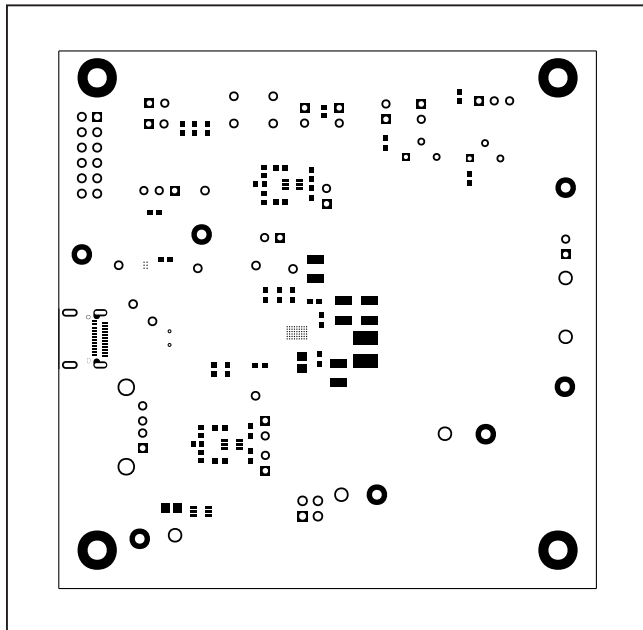

MAX14748 EV Kit—Mask Top

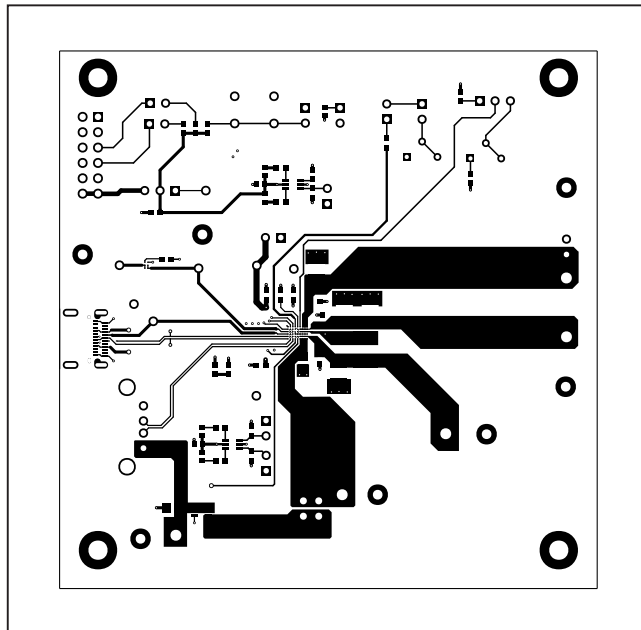

MAX14748 EV Kit—Top

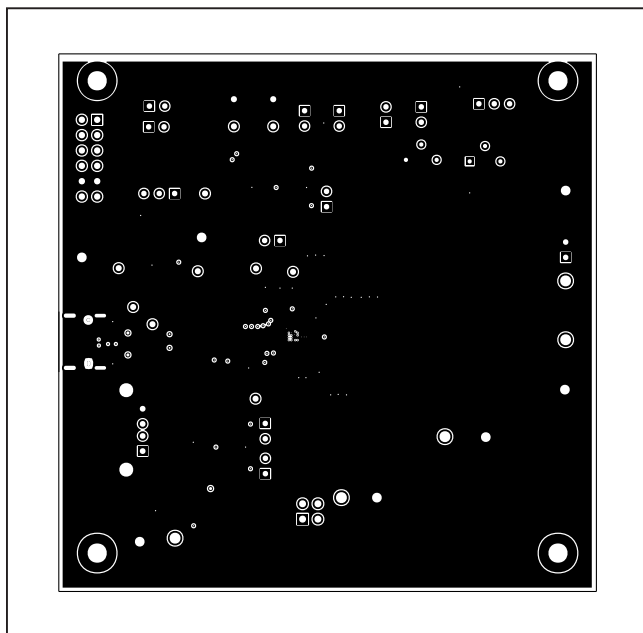

MAX14748 EV Kit—Level 2 GND

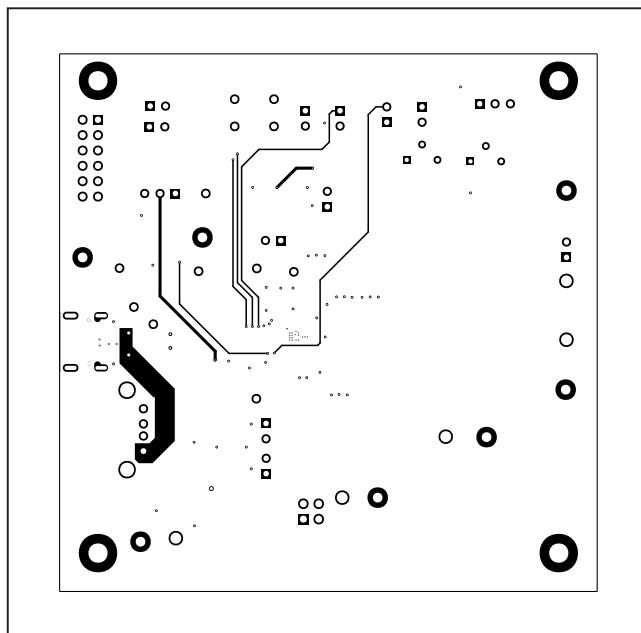

MAX14748 EV Kit—Level 3 SIGS

MAX14748 EV Kit PCB Layout Diagrams (continued)

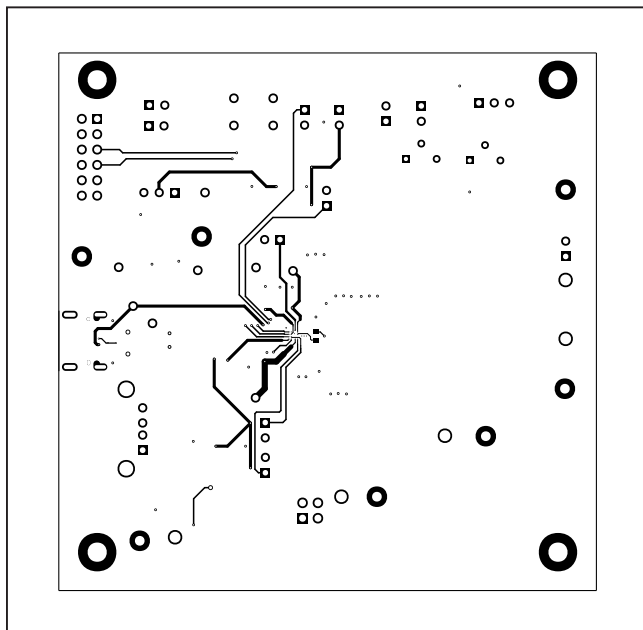

MAX14748 EV Kit—Bottom

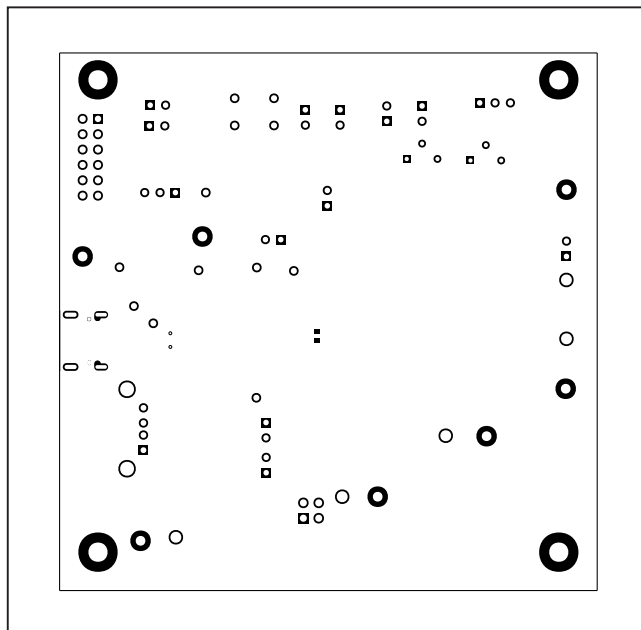

MAX14748 EV Kit—Mask Bottom

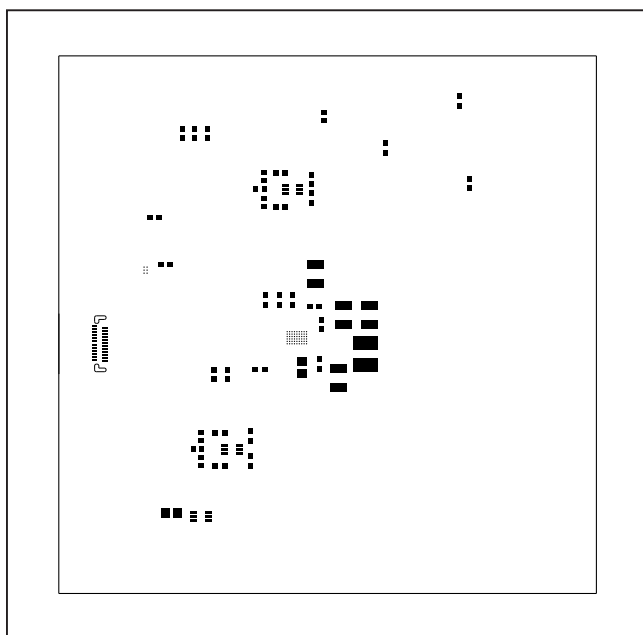

MAX14748 EV Kit—Paste Top

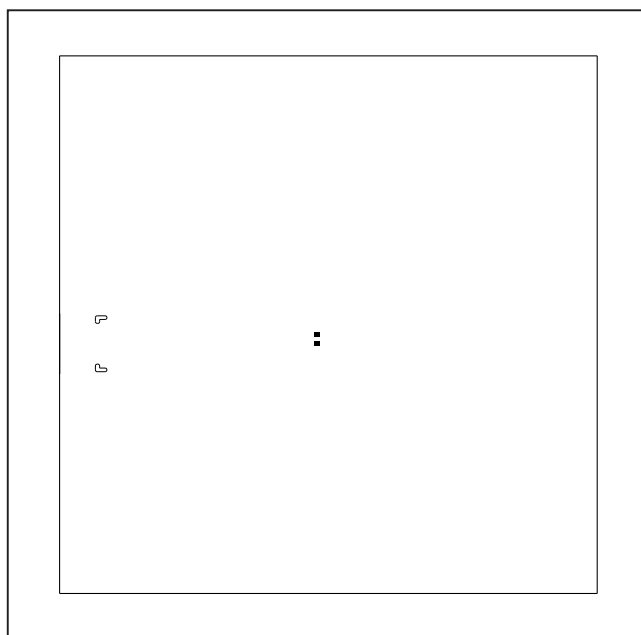

MAX14748 EV Kit—Paste Bottom

MAX14748 EV Kit PCB Layout Diagrams (continued)

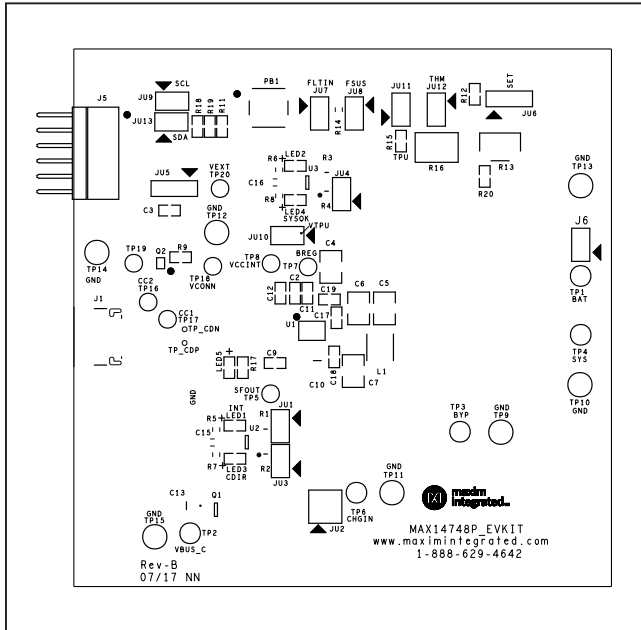

MAX14748 EV Kit—Silk Top

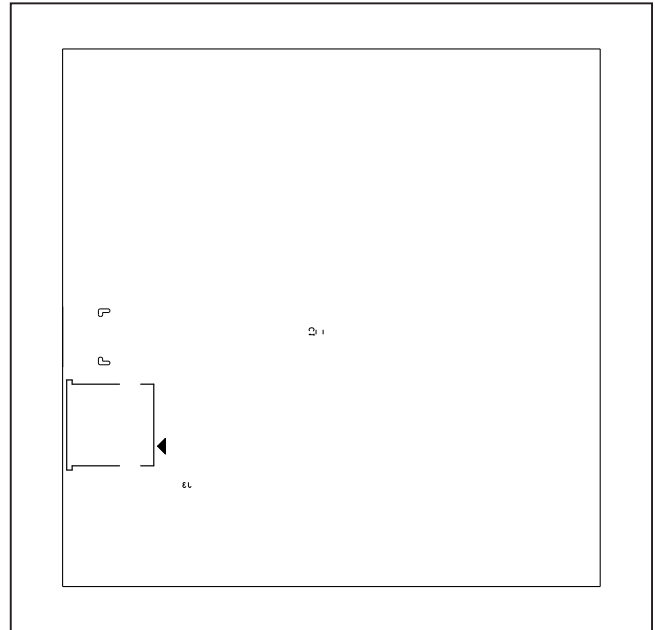

MAX14748 EV Kit—Silk Bottom

## Revision History

REVISION NUMBER	REVISION DATE	DESCRIPTION	PAGES CHANGED
0	9/17	Initial release	—
1	2/19	Added <i>Quick Start</i> section and updated the <i>Bill of Materials</i>	1, 5

For pricing, delivery, and ordering information, please visit Maxim Integrated's online storefront at <https://www.maximintegrated.com/en/storefront/storefront.html>.

*Maxim Integrated cannot assume responsibility for use of any circuitry other than circuitry entirely embodied in a Maxim Integrated product. No circuit patent licenses are implied. Maxim Integrated reserves the right to change the circuitry and specifications without notice at any time.*