

# PS20353

## Nordig Unified DVB-T COFDM Terrestrial Demodulator for PC-TV and hand-held Digital TV (DTV)

### Data Sheet



Data Sheet 292080 issue 1

### Features

- Compliant with ETSI 300 744 DVB-T, Nordig- Unified 1.0.2 and DTG performance specifications.
- High performance with fast fully blind acquisition and tracking capability.
- Low power consumption: less than 0.32 W, and eco-friendly standby and sleep modes.
- Digital filtering of adjacent channels.
- Single 8 MHz SAW filter for 6, 7 & 8 MHz OFDM.
- Superior single frequency network performance.
- Fast AGC to track out signal fades.
- Good Doppler tracking capability.
- Enhanced frequency capture range to include triple offsets.
- External 4 MHz clock or single low-cost 20.48 MHz crystal, tolerance up to +/-200 ppm.
- Automatic mode (2 K/8 K), guard and spectral inversion detection.
- Very low driver software overhead due to on-chip state-machine control.
- Novel RF level detect facility via a separate ADC.
- Pre and post Viterbi-decoder bit error rates, and uncorrectable block count.

### Applications

- Digital terrestrial set-top boxes
- Integrated digital televisions
- Personal video recorders
- PC-TV receivers
- Portable applications

### Description

The PS20353 is a superior fourth generation fully compliant ETSI ETS300 744 COFDM demodulator that exceeds, with margin, the performance requirements of all known DVB-T digital terrestrial television standards, including Unified Nordig and DTG.

### Ordering Information

PS20353C1L1A5	64 Pin LQFP*	Trays
PS20353C1L1AT	64 Pin LQFP*	Tape and Reel
* Pb Free Matte Tin (RoHS compliant)		

Working temperature range: -10°C to +80°C

A high performance 10 bit on-chip ADC is used to sample the 44 or 36 MHz IF analog signal. Advanced digital filtering of the upper and lower channel enables a single 8 MHz channel SAW filter to be used for 6, 7 and 8 MHz OFDM signal reception. All sampling and other internal clocks are derived from a single 20.48 MHz crystal or a 4 MHz clock input, the tolerance of which may be relaxed as much as 200 ppm.

The PS20353 has a wide frequency capture range able to automatically compensate for the combined offset introduced by the tuner xtal and broadcaster triple frequency offsets.

An on-chip state machine controls all acquisition and tracking operations of the PS20353 as well as controlling the tuner via a 2-wire bus. Any frequency range can be automatically scanned for digital TV channels. This mechanism ensures minimal interaction, maximum flexibility and fast acquisition - very low software overhead.

Also included in the design is a 7-bit ADC to detect the RF signal strength and thereby efficiently control the tuner RF AGC.

Users have access to all the relevant signal quality information, including input signal power level, signal-to-noise ratio, pre-Viterbi BER, post-Viterbi BER, and the uncorrectable block counts. The error rate monitoring periods are programmable over a wide range.

The device is packaged in a 10 x 10 mm 64-pin LQFP and is very low power.

Figure 1- Block Diagram

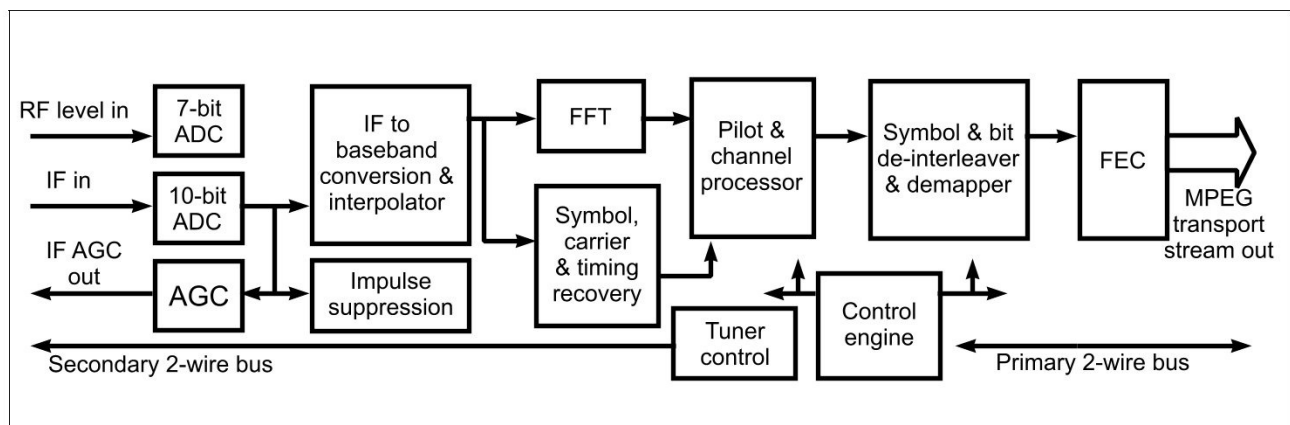

## Table of Contents

1	Pin & Package Details .....	5
1.1	Package dimensions.....	5
1.2	Pin Outline .....	5
1.3	Pin Allocation .....	6
1.4	Pin Description.....	7
2	Functional Description.....	9
2.1	Analogue-to-Digital Converter.....	10
2.2	Automatic Gain Control .....	10
2.3	IF to Baseband Conversion .....	10
2.4	Adjacent Channel Filtering.....	11
2.5	Interpolation and Clock Synchronisation .....	11
2.6	Carrier Frequency Synchronisation.....	11
2.7	Symbol Timing Synchronisation.....	11
2.8	Fast Fourier Transform .....	11
2.9	Common Phase Error Correction .....	11
2.10	Channel Equalisation.....	11
2.11	Impulse Filtering.....	11
2.12	Transmission Parameter Signalling (TPS) .....	11
2.13	De-Mapper .....	12
2.14	Symbol and Bit De-Interleaving.....	12
2.15	Viterbi Decoder .....	12
2.16	MPEG Frame Aligner .....	12
2.17	De-interleaver .....	12
2.18	Reed-Solomon Decoder .....	12
2.19	De-scrambler .....	12
2.20	MPEG Transport Interface.....	12

- 3 Interfaces ..... 13
  - 3.1 Wire Bus ..... 13
    - 3.1.1 Host ..... 13
    - 3.1.2 Tuner ..... 13
    - 3.1.3 Examples of 2-wire bus messages: ..... 14
    - 3.1.4 Primary 2-wire bus timing ..... 14
  - 3.2 MPEG ..... 15
    - 3.2.1 Data Output Header Format ..... 15
    - 3.2.2 MPEG Data Output Signals ..... 16
    - 3.2.3 MPEG Output Timing ..... 16
    - 3.2.4 MOCLKINV = 1 ..... 16
    - 3.2.5 MOCLKINV = 0 ..... 17
- 4 Electrical Characteristics ..... 19
  - 4.1 Operating Conditions ..... 19
  - 4.2 Absolute Maximum Ratings ..... 19
  - 4.3 DC Electrical Characteristics ..... 21
  - 4.4 AC Electrical Characteristics ..... 21
  - 4.5 Crystal Specification and External Clocking ..... 22
    - 4.5.1 Selection of External Components ..... 23
- 5 Application Circuit ..... 26

## List of Figures

Figure 1- Block Diagram .....	1
Figure 2 - Package dimensions.....	5
Figure 3- Pin Outline.....	5
Figure 4 - OFDM Demodulator Diagram.....	9
Figure 5- FEC Block Diagram .....	10
Figure 6- Primary 2-Wire Bus Timing .....	14
Figure 7 - DVB Transport Packet Header Byte.....	15
Figure 8- MPEG Output Data Waveforms .....	16
Figure 9 - MPEG Timing - MOCLKINV = 1 .....	17
Figure 10 - MPEG Timing - MOCLKINV = 0.....	17
Figure 11 - VIN & $\overline{\text{VIN}}$ equivalent circuit for inputs .....	22
Figure 12 - VIN & $\overline{\text{VIN}}$ input impedance (approximate) .....	22
Figure 13 - RFLEV equivalent circuit for input.....	22
Figure 14 - Crystal Oscillator Circuit.....	23
Figure 15 - External Clocking .....	25
Figure 16 - Typical Application Circuit.....	26

## List of Tables

Table 1 Pin Names - numeric.....	6
Table 2 Pin Names – alphabetical order .....	6
Table 3- 2-wire bus address .....	13
Table 4 – Timing of 2-Wire Bus.....	1

# 1 Pin & Package Details

## 1.1 Package dimensions

Figure 2 - Package dimensions

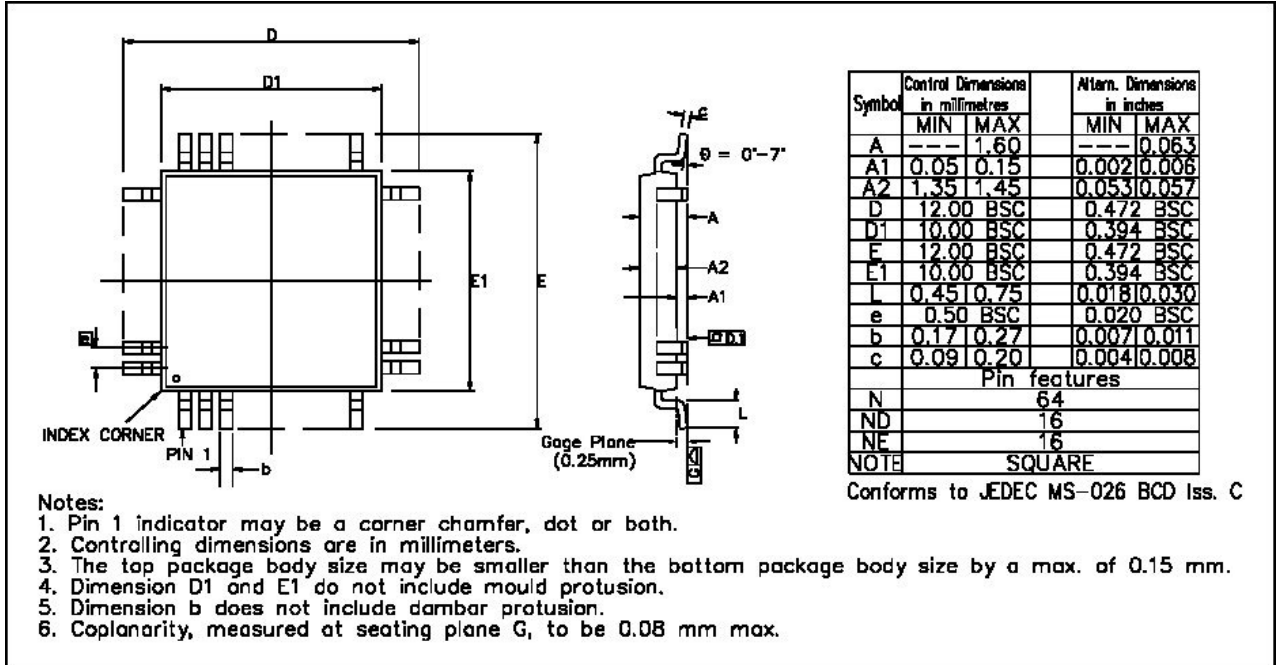

## 1.2 Pin Outline

Figure 3- Pin Outline

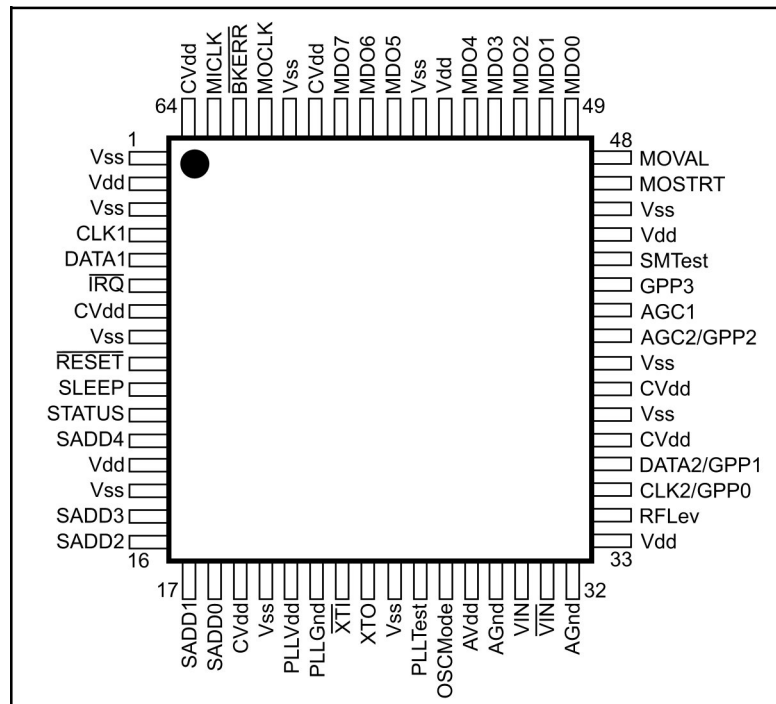

### 1.3 Pin Allocation

**Table 1 Pin Names - numeric**

Pin	Function	Pin	Function	Pin	Function	Pin	Function
1	Vss	17	SADD1	33	Vdd	49	MDO0
2	Vdd	18	SADD0	34	RFLEV	50	MDO1
3	Vss	19	CVdd	35	CLK2/GPP0	51	MDO2
4	CLK1	20	Vss	36	DATA2/GPP1	52	MDO3
5	DATA1	21	PLLvdd	37	CVdd	53	MDO4
6	$\overline{\text{IRQ}}$	22	PLLgND	38	Vss	54	Vdd
7	CVdd	23	$\overline{\text{XTI}}$	39	CVdd	55	Vss
8	Vss	24	XTO	40	Vss	56	MDO5
9	$\overline{\text{RESET}}$	25	Vss	41	AGC2/GPP2	57	MDO6
10	SLEEP	26	PLLTEST	42	AGC1	58	MDO7
11	STATUS	27	OSCMODE	43	GPP3	59	CVdd
12	SADD4	28	AVdd	44	SMTEST	60	Vss
13	Vdd	29	AGnd	45	Vdd	61	MOCLK
14	Vss	30	VIN	46	Vss	62	$\overline{\text{BKERR}}$
15	SADD3	31	$\overline{\text{VIN}}$	47	MOSTRT	63	MICLK
16	SADD2	32	AGnd	48	MOVAL	64	CVdd

**Table 2 Pin Names – alphabetical order**

Function	Pin	Function	Pin	Function	Pin	Function	Pin
AGC1	42	GPP3	43	PLLTEST	26	Vdd	54
AGC2/GPP2	41	$\overline{\text{IRQ}}$	6	PLLvdd	21	VIN	30
AGnd	29	MDO0	49	$\overline{\text{RESET}}$	9	$\overline{\text{VIN}}$	31
AGnd	32	MDO1	50	RFLEV	34	Vss	1
AVdd	28	MDO2	51	SADD0	18	Vss	3
$\overline{\text{BKERR}}$	62	MDO3	52	SADD1	17	Vss	8
CLK1	4	MDO4	53	SADD2	16	Vss	14
CLK2/GPP0	35	MDO5	56	SADD3	15	Vss	20
CVdd	7	MDO6	57	SADD4	12	Vss	25
CVdd	19	MDO7	58	SLEEP	10	Vss	38
CVdd	37	MICLK	63	SMTEST	44	Vss	40
CVdd	39	MOCLK	61	STATUS	11	Vss	46
CVdd	59	MOSTRT	47	Vdd	2	Vss	55
CVdd	64	MOVAL	48	Vdd	13	Vss	60
DATA1	5	OSCMODE	27	Vdd	33	$\overline{\text{XTI}}$	23
DATA2/GPP1	36	PLLgND	22	Vdd	45	XTO	24

## 1.4 Pin Description

Pin Description Table

Pin No	Name	Pin Description	I/O	Type	V	mA
MPEG pins						
47	MOSTRT	MPEG packet start	O	CMOS Tristate	3.3	2
48	MOVAL	MPEG data valid	O		3.3	
49-53, 56-58	MDO(0:4)/MDO(5:7)	MPEG data bus	O		3.3	
61	MOCLK	MPEG clock out	O		3.3	12
62	$\overline{\text{BKERR}}$	Block error	O		3.3	2
63	MICLK	MPEG clock in	I	CMOS	3.3	
11	STATUS	Status output	O		3.3	2
6	$\overline{\text{IRQ}}$	Interrupt output	O	Open drain	5	6
Control pins						
4	CLK1	Serial clock	I	CMOS	5	
5	DATA1	Serial data	I/O	Open drain	5	6
23	$\overline{\text{XTI}}$	Low phase noise oscillator	I	CMOS		
24	XTO		O			
10	SLEEP	Device power down	I		3.3	
12, 15-18	SADD(4:0)	Serial address set	I		3.3	
44	SMTEST	Production test (only set low)	I		3.3	
35	CLK2/GPP0	Serial clock tuner	I/O	Open drain	5	6
36	DATA2/GPP1	Serial data tuner	I/O		5	6
42	AGC1	Primary AGC	O		5	6
41	AGC2/GPP2	Secondary AGC	I/O		5	6
43	GPP(3)	General purpose I/O	I/O		5	6
9	$\overline{\text{RESET}}$	Device reset	I	CMOS	5	
27	OSCMODE	Crystal oscillator mode	I	CMOS	3.3	
26	PLLTEST	PLL analog test	O	(tristated)		
Analog inputs						
30	VIN	positive input	I			
31	$\overline{\text{VIN}}$	negative input	I			
34	RFLEV	RF level	I			
Supply pins						
21	PLLVdd	PLL supply	S		1.8	
22	PLLGnd		S		0	
7, 19, 37, 39, 59, 64	CVdd	Core logic power	S		1.8	
2, 13, 45, 54,	Vdd	I/O ring power	S		3.3	

Pin Description Table (continued)

Pin No	Name	Pin Description	I/O	Type	V	mA
1, 3, 8, 14, 20, 25, 38, 40, 46, 55, 60	Vss	Core and I/O ground	S		0	
28	AVdd	ADC analog supply	S		1.8	
29, 32	AGnd		S		0	
33	Vdd	2nd ADC supply	S		3.3	

## 2 Functional Description

A functional block diagram of the PS20353 OFDM demodulator is shown in Figure 4. This accepts an IF analogue signal and delivers a stream of demodulated soft decision data to the on-chip Viterbi decoder. Clock, timing and frequency synchronization operations are all digital and there are no analogue control loops except the AGC. The frequency capture range is large enough for all practical applications. This demodulator has novel algorithms to combat impulse noise as well as co-channel and adjacent channel interference. If the modulation is hierarchical, the OFDM outputs both high and low priority data streams. Only one of these streams is FEC-decoded, but the FEC can be switched from one stream to another with minimal interruption to the transport stream.

Figure 4 - OFDM Demodulator Diagram

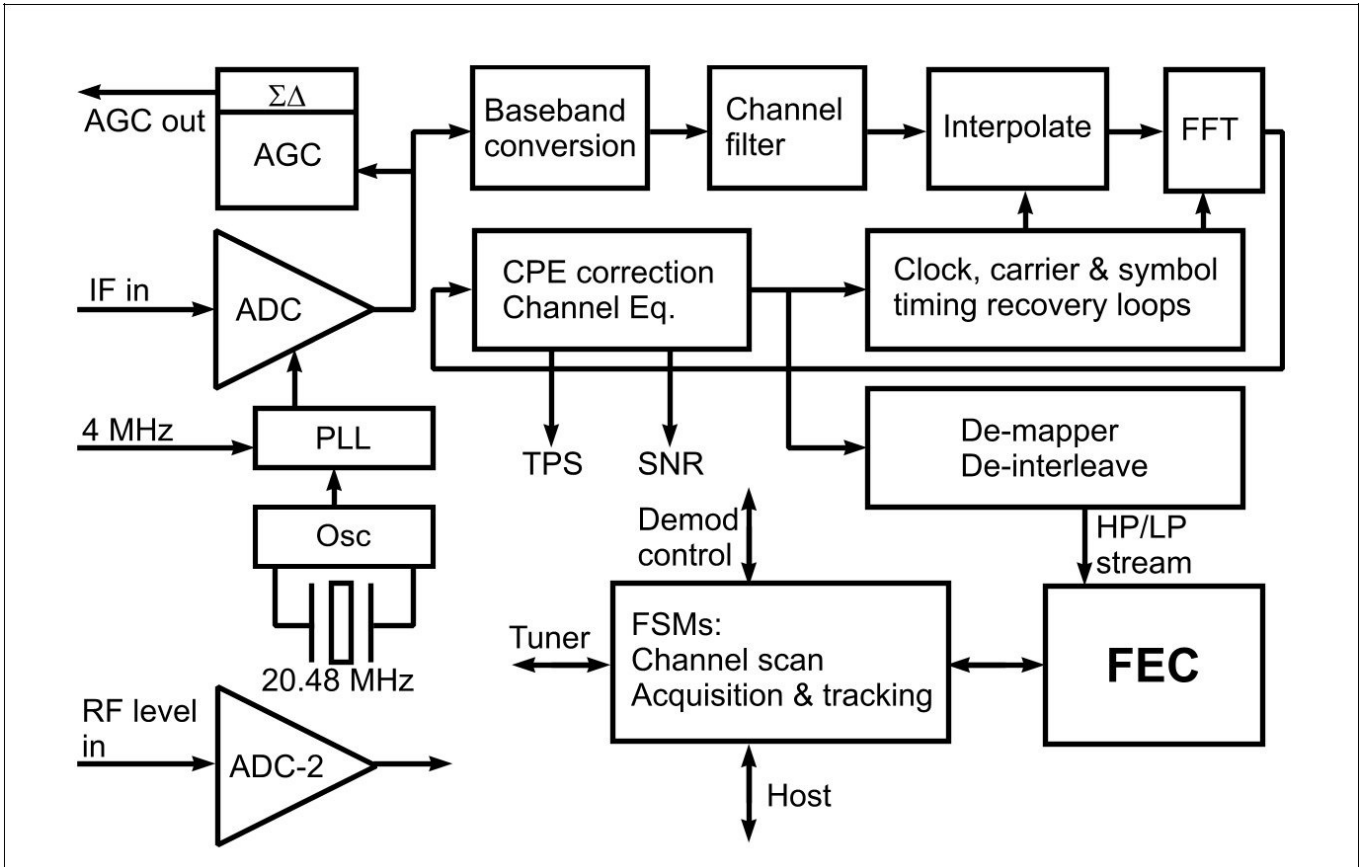

The FEC module shown in Figure 5 consists of a concatenated convolutional (Viterbi) and Reed-Solomon decoder separated by a depth-12 convolutional de-interleaver. The Viterbi decoder operates on 5-bit soft decisions to provide the best performance over a wide range of channel conditions. The trace-back depth of 128 ensures minimum loss of performance due to inevitable survivor truncation, especially at high code rates. Both the Viterbi and Reed-Solomon decoders are equipped with bit-error monitors. The former provides the bit error rate (BER) at the OFDM output. The latter is the more useful measure as it gives the Viterbi output BER. The error collecting intervals of these are programmable over a very wide range.

Figure 5- FEC Block Diagram

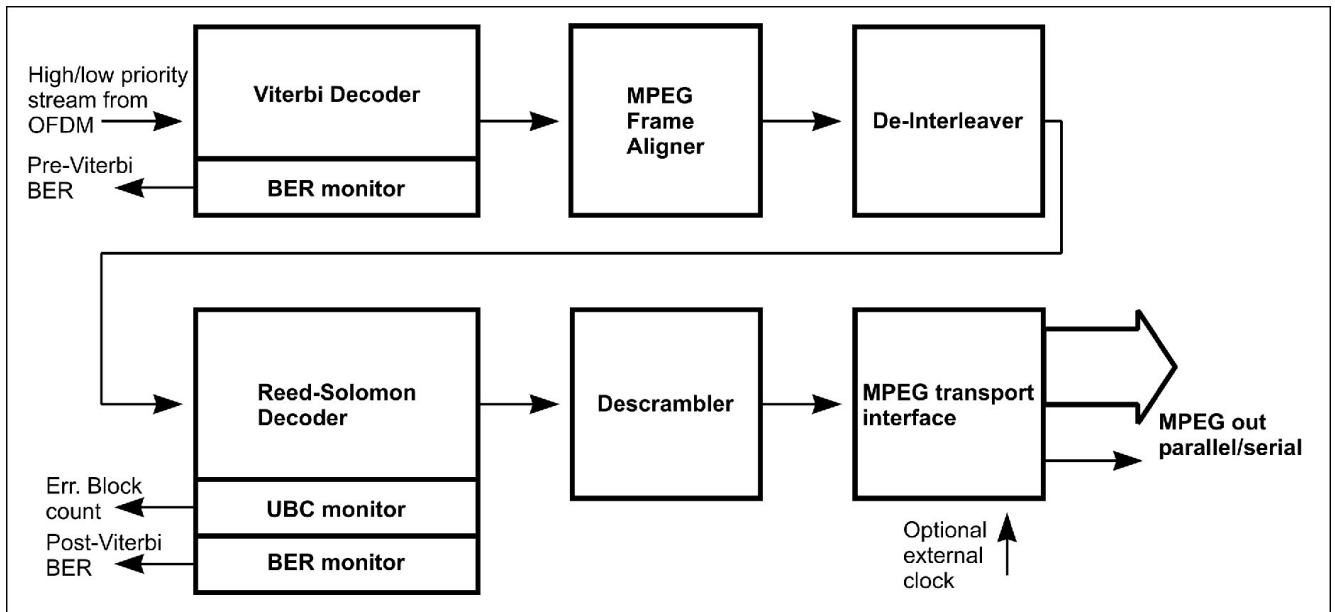

The FSM controller shown in Figure 4 controls both the demodulator and the FEC. It also drives the 2-wire bus to the tuner. The controller facilitates the automated search of all parameters or any sub-set of parameters of the received signal. It can also be used to scan any defined frequency range searching for OFDM channels. This mechanism provides the fast channel scan and acquisition performance, whilst requiring minimal software overhead in the host driver.

The algorithms and architectures used in the PS20353 have been optimized to minimize power consumption.

## 2.1 Analogue-to-Digital Converter

The PS20353 has a high performance 10-bit analogue-to-digital converter (ADC) which can sample a 6, 7 or 8 MHz bandwidth OFDM signal, with its spectrum centered at:

- 36.17 MHz IF
- 43.75 MHz IF
- 5 - 10 MHz near-zero IF

An on-chip programmable phase locked loop (PLL) is used to generate the ADC sampling clock. The PLL is highly programmable allowing a wide choice of sampling frequencies to suit any IF frequency, and all signal bandwidths.

## 2.2 Automatic Gain Control

An AGC module compares the absolute value of the digitized signal with a programmable reference. The error signal is filtered and is used to control the gain of the amplifier. A sigma-delta modulated output is provided, which has to be RC low-pass filtered to obtain the voltage to control the amplifier.

The programmable AGC reference has been optimized. A large value for the reference leads to excessive ADC clipping and a small value results in excessive quantization noise. Hence the optimum value has been determined assuming the input signal amplitude to be Gaussian distributed. The latter is justified by applying the central limit theorem in statistics to the OFDM signal, which consists of a large number of randomly modulated carriers. This reference or target value may have to be lowered slightly for some applications. Slope control bits have been provided for the AGCs and these have to be set correctly depending on the gain-versus-voltage slope of the gain control amplifiers.

The bandwidth of the AGC is set to a large value for quick acquisition then reduced to a small value for tracking. The AGC is free running during OFDM channel changes and locks to the new channel while the tuner lock is being established. This is one of the features of PS20353 used to minimize acquisition time. A robust AGC lock mechanism is provided and the other parts of the PS20353 begin to acquire only after the AGC has locked.

## 2.3 IF to Baseband Conversion

Sampling a 36.17 MHz IF signal at 45 MHz results in a spectrally inverted OFDM signal centered at approximately 8.9 MHz. The first step of the demodulation process is to convert this signal to a complex (in-phase and quadrature) signal in baseband. A correction for spectral inversion is implemented during this conversion process. Note also that the PS20353 has control mechanisms to search automatically for an unknown spectral inversion status.

## 2.4 Adjacent Channel Filtering

Adjacent channels, in particular the Nicam digital sound signal associated with analogue channels, are filtered prior to the FFT.

## 2.5 Interpolation and Clock Synchronization

PS20353 uses digital timing recovery and this eliminates the need for an external VCXO. The ADC samples the signal at a fixed rate, for example, 45.056 MHz. Conversion of the 45.056 MHz signal to the OFDM sample rate is achieved using the time-varying interpolator. The OFDM sample rate is 64/7 MHz for 8 MHz and this is scaled by factors 6/8 and 7/8 for 6 and 7 MHz channel bandwidths. The nominal ratio of the ADC to OFDM sample rate is programmed in a PS20353 register (defaults are for 45 MHz sampling and 8 MHz OFDM). The clock recovery phase locked loop in the PS20353 compensates for inaccuracies in this ratio due to uncertainties of the frequency of the sampling clock.

## 2.6 Carrier Frequency Synchronization

There can be frequency offsets in the signal at the input to OFDM, partly due to tuner step size and partly due to broadcast frequency shifts, typically 1/6 MHz. These are tracked out digitally, up to 1 MHz in 2 K and 8 K modes, without the need for an analogue frequency control (AFC) loop.

The default frequency capture range has been set to  $\pm 286$  kHz in the 2 K and 8 K mode. However, these values can be increased, if necessary, by programming an on-chip register (see details in the design manual). It is recommended that a larger capture range be used for channel scan in order to find channels with broadcast frequency shifts, without having to adjust the tuner. After the OFDM module has locked (the AFC will have been previously disabled), the frequency offset can be read from an on-chip register.

## 2.7 Symbol Timing Synchronization

This module computes the optimum sample position to trigger the FFT in order to eliminate or minimize inter-symbol interference in the presence of multi-path distortion. Furthermore, this trigger point is continuously updated to dynamically adapt to time-variations in the transmission channel.

## 2.8 Fast Fourier Transform

The FFT module uses the trigger information from the timing synchronization module to set the start point for an FFT. It then uses either a 2 K or 8 K FFT to transform the data from the time domain to the frequency domain. An extremely hardware-efficient and highly accurate algorithm has been used for this purpose.

## 2.9 Common Phase Error Correction

This module subtracts the common phase offset from all the carriers of the OFDM signal to minimize the effect of the tuner phase noise on system performance.

## 2.10 Channel Equalization

This consists of two parts. The first part involves estimating the channel frequency response from pilot information. Efficient algorithms have been used to track time-varying channels with a minimum of hardware.

The second part involves applying a correction to the data carriers based on the estimated frequency response of the channel. This module also generates dynamic channel state information (CSI) for every carrier in every symbol.

## 2.11 Impulse Filtering

PS20353 contains several mechanisms to reduce the impact of impulse noise on system performance.

## 2.12 Transmission Parameter Signaling (TPS)

An OFDM frame consists of 68 symbols and a super frame is made up of four such frames. There is a set of TPS carriers in every symbol and all these carry one bit of TPS. These bits, when combined, include information about the transmission mode, guard ratio, constellation, hierarchy and code rate, as defined in ETS 300 744. In addition, the first eight bits of the cell identifier are contained in even frames and the second eight bits of the cell identifier are in odd frames. The TPS module extracts all the TPS data, and presents these to the host processor in a structured manner.

## 2.13 De-Mapper

This module generates soft decisions for demodulated bits using the channel- equalized in-phase and quadrature components of the data carriers as well as per-carrier channel state information (CSI). The de-mapping algorithm depends on the constellation (QPSK, 16 QAM or 64 QAM) and the hierarchy ( $\alpha = 0, 1, 2$  or  $4$ ). Soft decisions for both low- and high-priority data streams are generated.

## 2.14 Symbol and Bit De-Interleaving

The OFDM transmitter interleaves the bits within each carrier and also the carriers within each symbol. The de-interleaver modules consist largely of memory to invert these interleaving functions and present the soft decisions to the FEC in the original order.

## 2.15 Viterbi Decoder

The Viterbi decoder accepts the soft decision data from the OFDM demodulator and outputs a decoded bit-stream. The decoder does the de-puncturing of the input data for all code rates other than  $1/2$ . It then evaluates the branch metrics and passes these to a 64-state path-metric updating unit, which in turn outputs a 64-bit word to the survivor memory. The Viterbi decoded bits are obtained by tracing back the survivor paths in this memory. A trace-back depth of 128 is used to minimize any loss in performance, especially at high code rates.

The decoder re-encodes the decoded bits and compares these with received data (delayed) to compute bit errors at its input, on the assumption that the Viterbi output BER is significantly lower than its input BER.

## 2.16 MPEG Frame Aligner

The Viterbi decoded bit stream is aligned into 204 -byte frames. A robust synchronization algorithm is used to ensure correct lock and to prevent loss of lock due to noise impulses.

## 2.17 De-interleaver

Errors at the Viterbi output occur in bursts and the function of the de-interleaver is to spread these errors over a number of 204-byte frames to give the Reed-Solomon decoder a better chance of correcting these. The de-interleaver is a memory unit which implements the inverse of the convolutional interleaving function introduced by the transmitter.

## 2.18 Reed-Solomon Decoder

Every 188-byte transport packet is encoded by the transmitter into a 204-byte frame, using a truncated version of a systematic (255,239) Reed-Solomon code. The corresponding (204,188) Reed-Solomon decoder is capable of correcting up to eight byte errors in a 204-byte frame. It may also detect frames with more than eight byte errors.

In addition to efficiently performing this decoding function, the Reed-Solomon decoder in PS20353 keeps a count of the number of bit errors corrected over a programmable period and the number of uncorrectable blocks. This information can be used to compute the post-Viterbi BER.

## 2.19 De-scrambler

The de-scrambler de-randomizes the Reed-Solomon decoded data by generating the exclusive -OR of this with a pseudo -random bit sequence (PRBS). This outputs 188-byte MPEG transport packets. The TEI bit of the packet header may be set if required to indicate uncorrectable packets.

## 2.20 MPEG Transport Interface

MPEG data can be output in parallel or serial mode. The output clock frequency is automatically chosen to present the MPEG data as uniformly spaced as possible to the transport processor. This frequency depends on the guard ratio, constellation, hierarchy and code rate. There is also an option for the data to be extracted from the with a clock provided by the user.

## 3 Interfaces

### 3.1 Wire Bus

#### 3.1.1 Host

The primary 2-wire bus serial interface uses pins:

- DATA1 (pin5) serial data, the most significant bit is sent first.
- CLK1 (pin 4) serial clock.

The 2-wire bus address is determined by a combination of internal settings and applying Vdd or Gnd to the SADD[4:0] pins:

**Table 3- 2-wire bus address**

Address bits	ADDR[7]	ADDR[6]	ADDR[5]	ADDR[4]	ADDR[3]	ADDR[2]	ADDR[1]
Internal/external settings	Gnd	Gnd	SADD[4]	SADD[3]	SADD[2]	SADD[1]	SADD[0]
Normal TNIM settings	Gnd	Gnd	Gnd	Vdd	Vdd	Vdd	Vdd

When the PS20353 is powered up, the  $\overline{\text{RESET}}$  pin 9 should be held low for at least 50 ms after Vdd has reached normal operation levels. As the  $\overline{\text{RESET}}$  pin goes high, the logic levels on SADD[4:0] are latched as the 2-wire bus address. ADDR[0] is the R/W bit.

The circuit works as a slave transmitter with the lsb set high or as a slave receiver with the lsb set low. In receive mode, the first data byte is written to the RADD virtual register, which forms the register sub- address. The RADD register takes an 8-bit value that determines which of 256 possible register addresses is written to by the following byte. Not all addresses are valid and many are reserved registers that must not be changed from their default values. Multiple byte reads or writes will auto-increment the value in RADD, but care should be taken not to access the reserved registers accidentally.

Following a valid chip address, the 2-wire bus STOP command resets the RADD register to 00. If the chip address is not recognized, the PS20353 will ignore all activity until a valid chip address is received. The 2-wire bus START command does NOT reset the RADD register to 00. This allows a combined 2-wire bus message, to point to a particular read register with a write command, followed immediately with a read data command. If required, this could next be followed with a write command to continue from the latest address. RADD would not be sent in this case. Finally, a STOP command should be sent to free the bus.

When the 2 -wire bus is addressed (after a recognized STOP command) with the read bit set, the first byte read out is the contents of register 00.

#### 3.1.2 Tuner

The PS20353 has a General Purpose Port that can be configured to provide a secondary 2-wire bus.

Master control mode is selected by setting register SCAN\_CTL (0x62) [b3] = 1.

The allocation of the pins is: GPP0 pin 35 = CLK2\*, GPP1 pin 36 = DATA2.

\*. Please note that in this configuration, this pin is an output only and therefore does not allow a clock-hold function in the slave device.

**3.1.3 Examples of 2-wire bus messages:**

KEY:	S	Start condition	W	Write (= 0)
	P	Stop condition	R	Read (= 1)
	A	Acknowledge	NA	NOT Acknowledge
	<i>Italics</i>	PS20353 output	RADD	Register Address

Write operation - as a slave receiver:

S	DEVICE ADDRESS	W	A	RADD (n)	A	DATA (reg n)	A	DATA (reg n+1)	A	P
---	----------------	---	---	----------	---	--------------	---	----------------	---	---

Read operation - PS20353 as a slave transmitter:

S	DEVICE ADDRESS	R	A	DATA (reg 0)	A	DATA (reg 1)	A	DATA (reg 2)	NA	P
---	----------------	---	---	--------------	---	--------------	---	--------------	----	---

Write/read operation with repeated start - PS20353 as a slave transmitter:

S	DEVICE ADDRESS	W	A	RADD (n)	A	S	DEVICE ADDRESS	R	A	DATA (reg n)	A	DATA (reg n+1)	NA	P
---	----------------	---	---	----------	---	---	----------------	---	---	--------------	---	----------------	----	---

**3.1.4 Primary 2-wire bus timing**

Figure 6- Primary 2-Wire Bus Timing

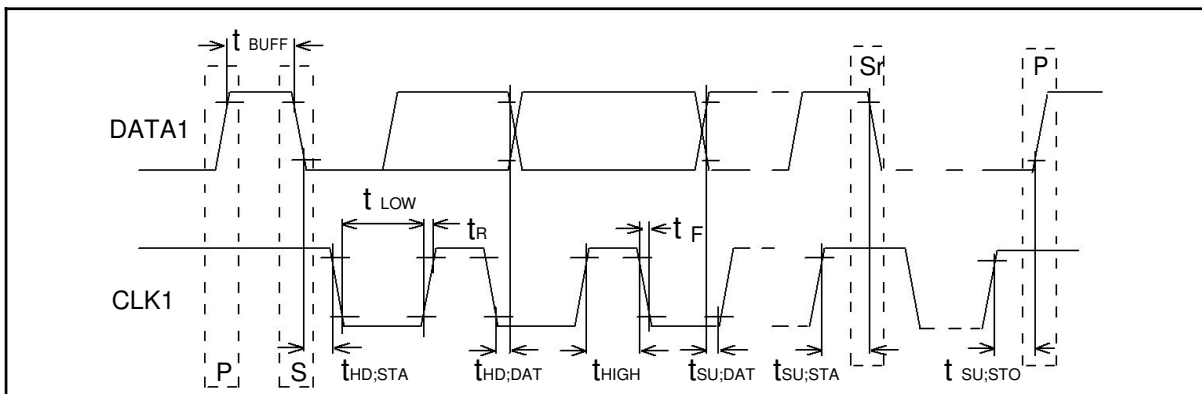

Where: S = Start  
 Sr = Restart, i.e., start without stopping first.  
 P = Stop.

Table 4 – Timing of 2-Wire Bus

Parameter	Symbol	Values with 4MHz clock		Values with 20.48 MHz clock*		Unit
		Min.	Max.	Min.	Max.	
CLK clock frequency (Primary)	f <sub>CLK</sub>	0	100	0	400	kHz
Bus free time between a STOP and START condition.	t <sub>BUFF</sub>	4.7		1.3		μs
Hold time (repeated) START condition.	t <sub>HD;STA</sub>	4.0		0.6		μs
LOW period of CLK clock.	t <sub>LOW</sub>	4.7		1.3		μs
HIGH period of CLK clock.	t <sub>HIGH</sub>	4.0		0.6		μs
Set-up time for a repeated START condition.	t <sub>SU;STA</sub>	4.7		0.6		μs
Data hold time (when input).	t <sub>HD;DAT</sub>	0	3.45	0	0.9	μs
Data set-up time	t <sub>SU;DAT</sub>	250		100		ns
Rise time of both CLK and DATA signals.	t <sub>R</sub>		1000	20 + 0.1C <sub>b</sub> †	300	ns
Fall time of both CLK and DATA signals, (100pF to ground).	t <sub>F</sub>		300	20 + 0.1C <sub>b</sub> †	300	ns
Set-up time for a STOP condition.	t <sub>SU;STO</sub>	4.0		0.6		μs

\*. Or 27.00 MHz clock

†. C<sub>b</sub> = the total capacitance on either clock or data line in pF to maximum of 400pF.

### 3.2 MPEG

#### 3.2.1 Data Output Header Format

Figure 7 - DVB Transport Packet Header Byte

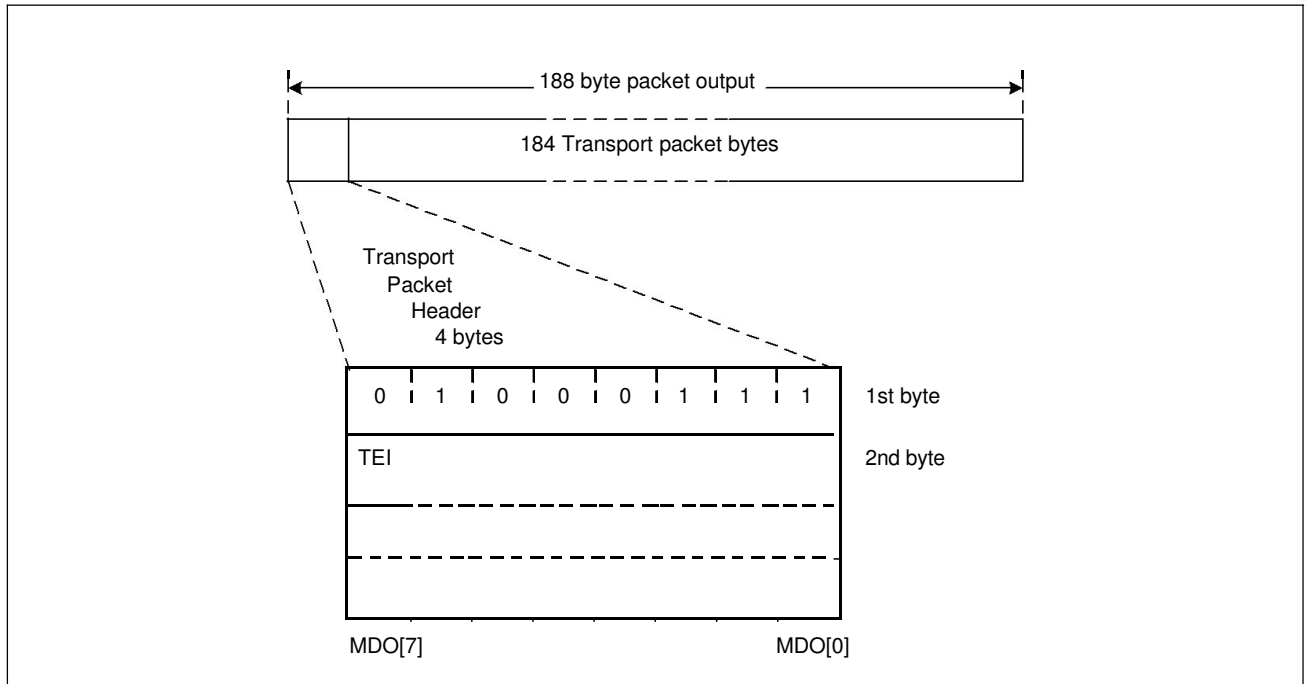

After decoding the 188-byte MPEG packet, it is output on the MDO pins in 188 consecutive clock cycles.

Additionally when the TEI\_En bit in the OP\_CTRL\_0 register (0x5A) is set high (default), the TEI bit of any uncorrectable packet will automatically be set to '1'. If TEI\_En bit is low then TEI bit will not be changed (but note that if this bit is already 1, for example, due to a channel error which has not been corrected, it will remain high at output).

### 3.2.2 MPEG Data Output Signals

The  $\overline{\text{MPEGEN}}$  bit in the CONFIG register must be set low to enable the MPEG data. The maximum movement in the packet synchronization byte position is limited to  $\pm 1$  output clock period. MOCLK will be a continuously running clock once symbol lock has been achieved, and is derived from the symbol clock. MOCLK is shown in Figure 8 with MOCLKINV = '1', the default state, see register 0x50.

All output data and signals (MDO[7:0], MOSTRT, MOVAL &  $\overline{\text{BKERR}}$ ) change on the negative edge of MOCLK (MOCLKINV = 1) to present stable data and signals on the positive edge of the clock.

A complete packet is output on MDO[7:0] on 188 consecutive clocks and the MDO[7:0] pins will remain low during the inter-packet gaps. MOSTRT goes high for the first byte clock of a packet. MOVAL goes high on the first byte of a packet and remains high until the last byte has been clocked out.  $\overline{\text{BKERR}}$  goes low on the first byte of a packet where uncorrectable bytes are detected and will remain low until the last byte has been clocked out.

Figure 8- MPEG Output Data Waveforms

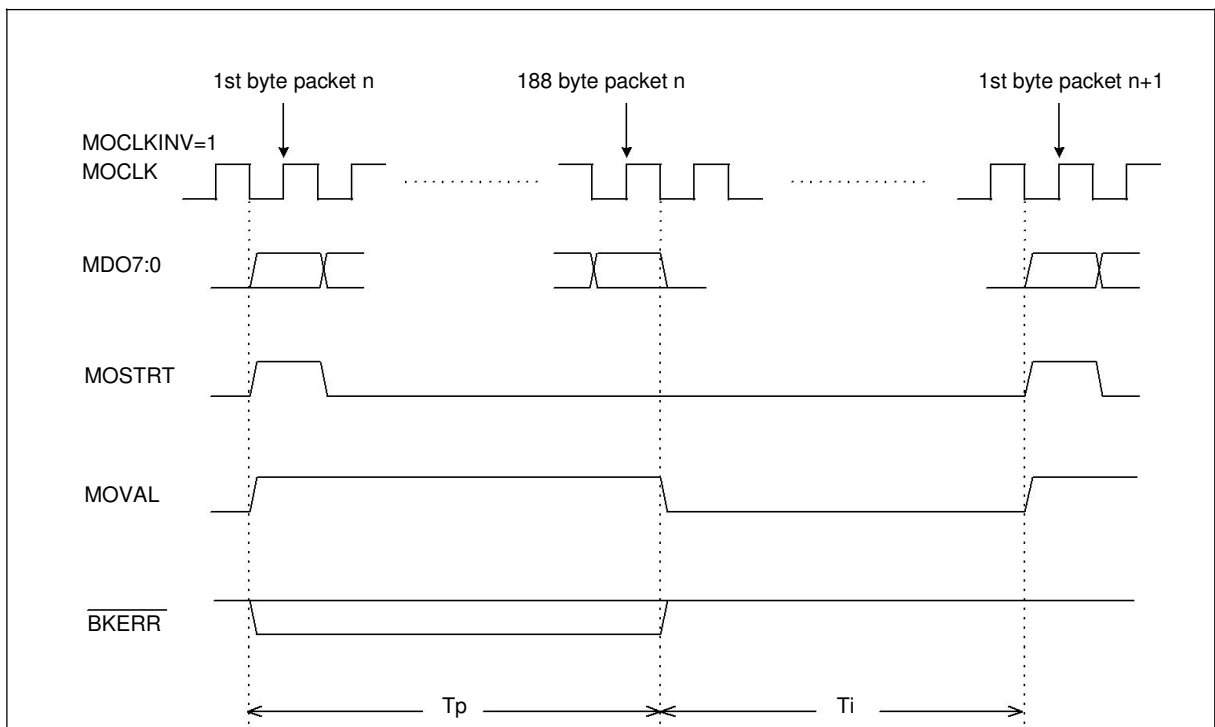

### 3.2.3 MPEG Output Timing

Maximum delay conditions: Vdd = 3.0V, CVdd = 1.62V, Tamb = 80°C, Output load = 10pF.

Minimum delay conditions: Vdd = 3.6V, CVdd = 1.98V, Tamb = -10°C, Output load = 10pF.

MOCLK frequency = 45.06 MHz.

### 3.2.4 MOCLKINV = 1

Parameter	Delay conditions		Units
	Maximum	Minimum	
Data output delay $t_D$	3.0	1.0	ns
Setup Time $t_{SU}$	7.0	10.0	
Hold Time $t_H$	7.0	10.0	

Figure 9 - MPEG Timing - MOCLKINV = 1

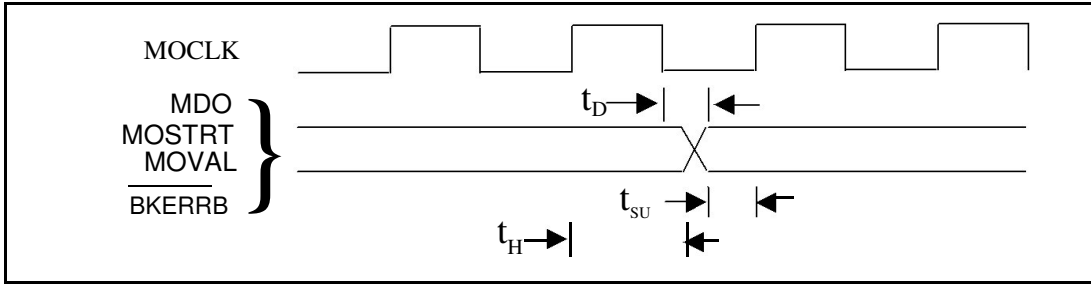

**3.2.5 MOCLKINV = 0**

MDOSWAP = 0

Parameter	Delay Conditions		Units
	Maximum	Minimum	
Data output delay $t_D$	3.0	1.0	ns
Setup Time $t_{SU}$	18.0	20.0	
Hold Time $t_H$	1.0	0.2	

The hold time is better when MOCLKINV = 1, therefore this should be used if possible.

Figure 10 - MPEG Timing - MOCLKINV = 0

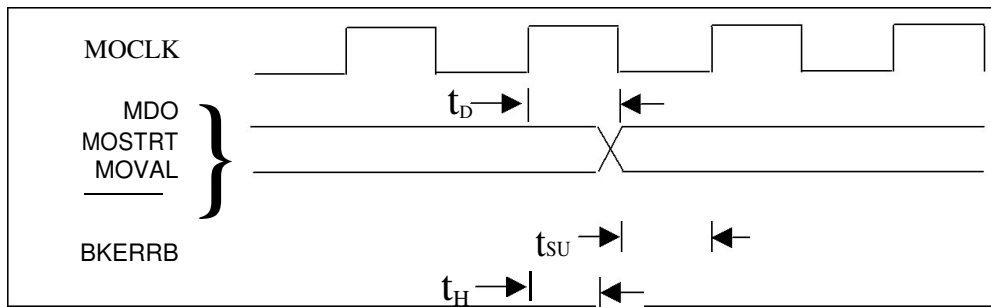



## 4 Electrical Characteristics

### 4.1 Operating Conditions

Recommended Operating Conditions

Parameter	Symbol	Min.	Typ.	Max.	Units	
Power supply voltage:	periphery	Vdd	3.0	3.3	3.6	V
	core	CVdd	1.62	1.8	1.98	V
Power supply current:	periphery *	I <sub>ddP</sub>		1		mA
	core	I <sub>ddC</sub>		170		mA †
Input clock frequency ‡	XTI	16.00	20.48	25.00	MHz	
CLK1 primary serial clock frequency **	f <sub>CLK</sub>			400	kHz	
Ambient operating temperature		-10		80	°C	

\*. Current from the 3.3 V supply will be mainly dependent on the external loads.

†. Current given is for optimum performance, lower current is possible with reduced performance.

‡. The min/max frequencies given are those supported by the oscillator cell. Required system frequencies are as defined in the design manual. Frequencies outside these limits are acceptable with an external clock signal.

\*\* . If operating with an external 4 MHz clock, the serial clock frequency is reduced to 100 kHz maximum.

### 4.2 Absolute Maximum Ratings

Maximum Operating Conditions

Parameter	Symbol	Min.	Max.	Unit	Conditions
Power supply	Vdd		+3.6	V	
	CVdd		+2.0	V	
Voltage on input pins (5 V rated)	VI	-0.3	5.5	V	
Voltage on input pins (3.3 V rated)			Vdd + 0.3	V	
Voltage on analog input pins (VIN & VIN <sup>+</sup> )			V	V	Pin 33 = Vdd
Voltage on analog input pins (VIN & VIN <sup>-</sup> )			CVdd + 0.3	V	Pin 33 = CVdd*
Voltage on output pins (5 V rated)	VO		5.5	V	
Voltage on output pins (3.3V rated)			Vdd + 0.3	V	
ESD ratings (all pins):					
HBM		±2000		V	
CDM		±800		V	
Storage temperature	TSTG	-55	150	°C	
Operating ambient temperature	TOP	-10	80	°C	
Junction temperature	TJ		125	°C	

\*. this condition will only occur if PS20353 is being used in a board originally designed for the MT352. All other applications should have Vdd (3V3) on this pin.

Note: Stresses exceeding these listed under absolute maximum ratings may induce failure. Exposure to absolute maximum ratings for extended periods may reduce reliability. Functionality at or above these conditions is not implied.





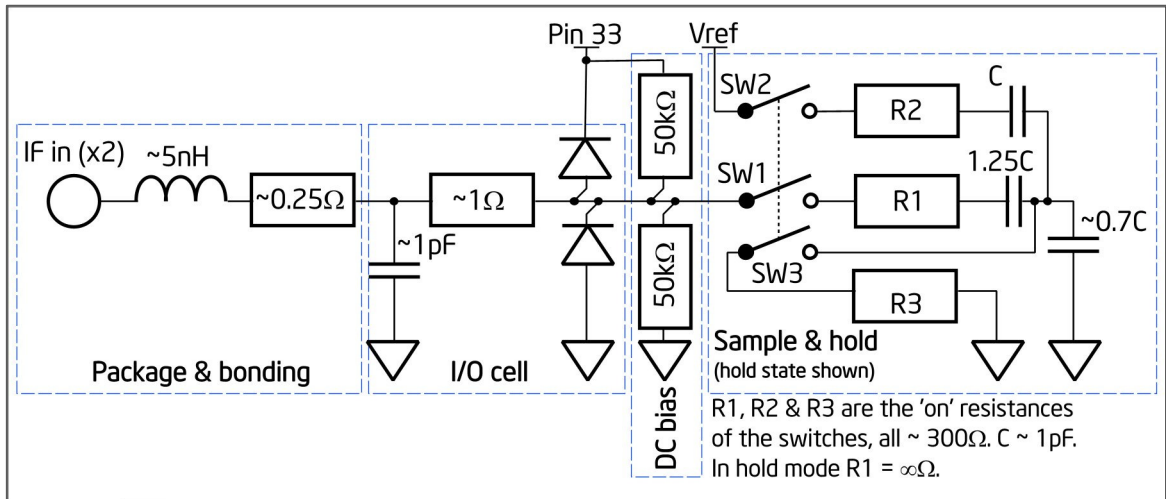

Figure 12 - VIN & VIN input impedance (approximate)

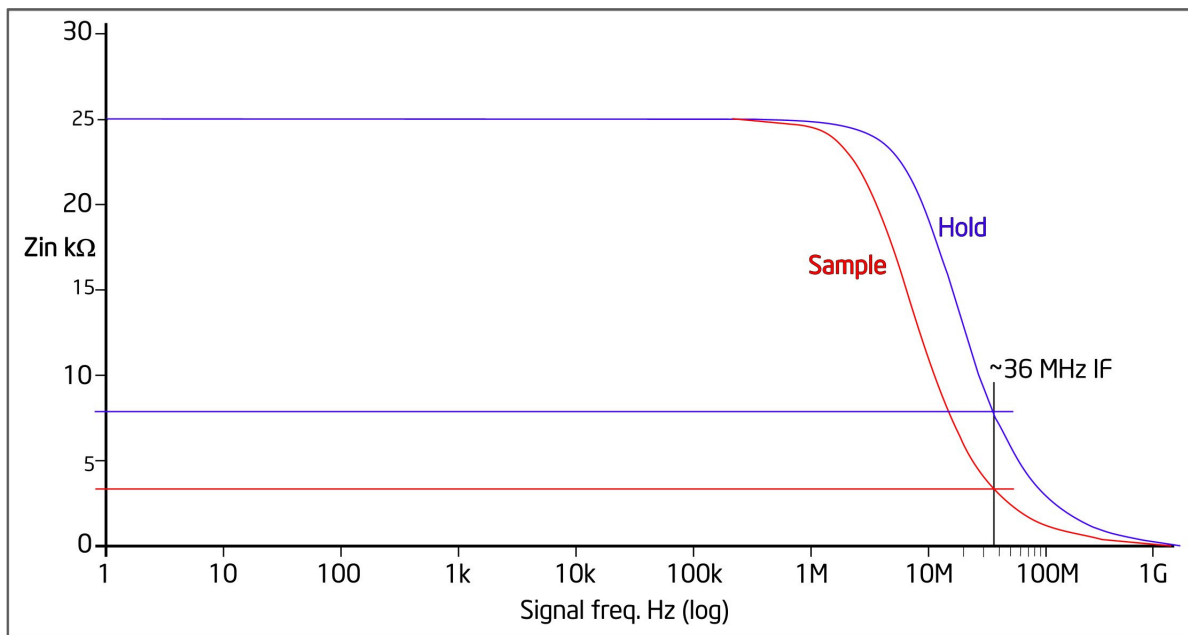
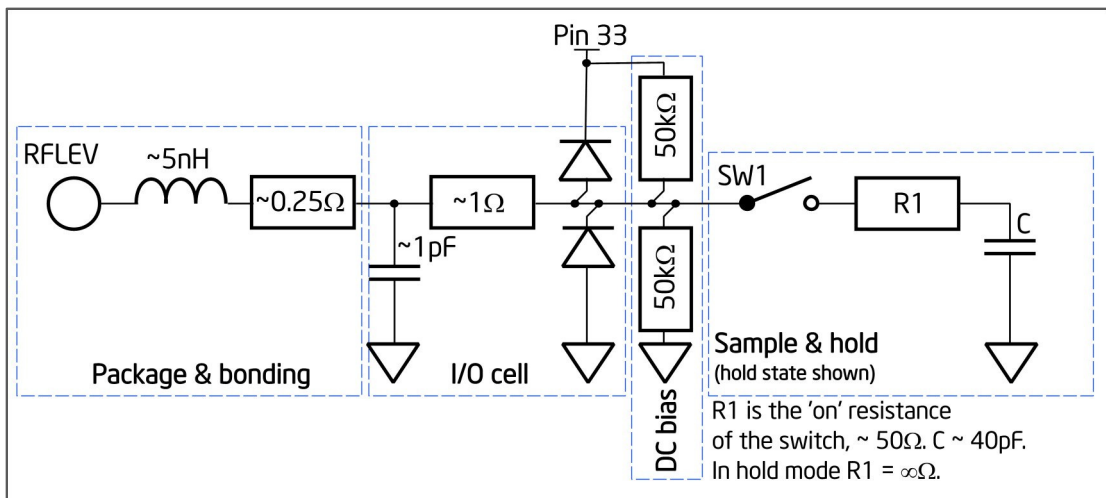

Figure 13 - RFLEV equivalent circuit for input



### 4.5 Crystal Specification and External Clocking

Parallel resonant fundamental frequency (preferred)	20.4800 MHz
Tolerance over operating temperature range	$\pm 150\text{ ppm}$
Tolerance overall	$\pm 200\text{ ppm}$

PS20353

Typical load capacitance 20 pF  
 Drive level 0.4 mW max  
 Equivalent series resistance <40 Ω

**Figure 14 - Crystal Oscillator Circuit**

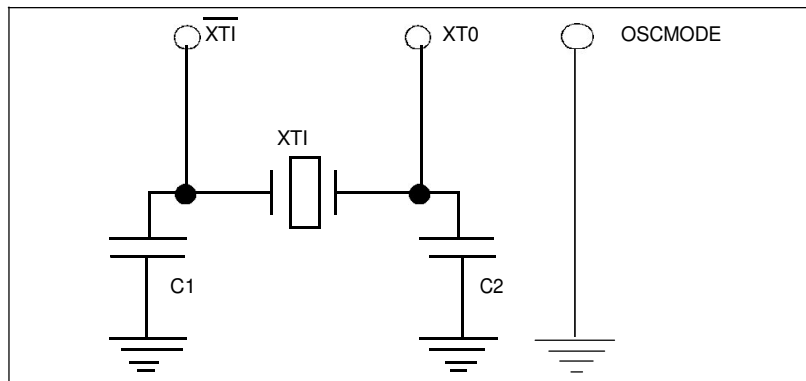

### 4.5.1 Selection of External Components

The capacitor values used must ensure correct operation of the Pierce oscillator such that the total loop gain is greater than unity. Correct selection of the two capacitors is very important and the following method is recommended to obtain values for C1 and C2. Alternatively there is a calculator available (ZLAN-125) that will calculate the external component values for you.

#### 4.5.1.1 Loop Gain Equation

Although oscillation may still occur if the loop gain is just above 1, a loop gain of between 5 and 25 is optimum to ensure that oscillations will occur across all variations in temperature, process and supply voltage, and that the circuit will exhibit good start-up characteristics.

Equation 1 - 
$$A = \frac{C_{out} \cdot g_m}{C_{in}} \left[ \frac{C_{out} + C_{in}}{R_f \cdot C_{in}} + \frac{1}{Z_{in}} + \frac{1}{Z_o} \right]^{-1}$$

Equation 2 - 
$$Z_{in} = \frac{1}{(2 \cdot \pi \cdot f \cdot C_{out})^2 \cdot ESR}$$

#### 4.5.1.2 List of Equation Parameters

A	total loop gain (between 5 and 25)
C <sub>in</sub>	C1 + C <sub>par</sub>
C <sub>out</sub>	C2 + C <sub>par</sub>
C <sub>par</sub>	parasitic capacitance associated with each oscillator pin ( $\overline{XT1}$ and XT0). It consists of track capacitances, package capacitance and cell input capacitance. Normally C <sub>par</sub> ≈ 4pF.
Z <sub>o</sub>	9.143kΩ - output impedance of amplifier at 1.8V operation - typical
g <sub>m</sub>	8.736mA/V - transconductance of amplifier at 1.8V operation -typical
R <sub>f</sub>	2.3MΩ - internal feedback resistor
ESR	maximum equivalent series resistance of crystal - given by crystal manufacturer (Ω)
f	fundamental frequency of crystal (Hz)

#### 4.5.1.3 Calculating Crystal Power Dissipation

To calculate the power dissipated in a crystal the following equation can be used.

$$\text{Equation 3 - } P_c = \frac{V_{pp}^2}{8 \cdot Z_{in}}$$

$P_c$  = power dissipated in crystal at resonant frequency (W)

$V_{pp}$  = maximum peak to peak output swing of amplifier is 1.8V for all CVdd

$Z_{in}$  = crystal network impedance (see Equation 2)

#### 4.5.1.4 Capacitor Values

Using the loop gain limits ( $5 \leq A \leq 25$ ), the maximum and minimum values for  $C_1$  and  $C_2$  can be calculated with Equation 4 below.

$$\text{Equation 4 - } C_{in} = C_{out} = \sqrt{\left[ \frac{g_m}{A} - \frac{2}{R_f} - \frac{1}{Z_0} \right] \cdot \frac{1}{(2 \cdot \pi \cdot f)^2 \cdot ESR}} \quad \text{when: } C_1 = C_2 = C_{out} - C_{par}$$

Note: Equation 4 was derived from Equation 1 and Equation 2 using the premise that  $C_1 = C_2$ .

Within these limits, any value for  $C_1$  and  $C_2$  can now be selected. Normally  $C_1$  and  $C_2$  are chosen such that the resulting crystal load capacitance  $C_L$  (see Equation 5) is close to the crystal manufacturers recommended  $C_L$  (standard values for  $C_L$  are 15pF, 20pF and 30pF). The crystal will then operate very near its specified frequency.

$$\text{Equation 5 - } C_L = \frac{C_{out} \cdot C_{in}}{C_{out} + C_{in}} + C_{par12}$$

$C_{par12}$  = parasitic capacitance between the  $\overline{XTI}$  and XTO pins. It consists of the IC package's pin-to-pin capacitance (including any socket used) and the printed circuit board's track-to-track capacitance.

$C_{par12} \approx 2\text{pF}$ .

If some frequency pulling can be tolerated, a crystal load capacitance different from the crystal manufacturer's recommended  $C_L$  may be acceptable. Larger values of  $C_L$  tend to reduce the influence of circuit variations and tolerances on frequency stability. Smaller values of  $C_L$  tend to reduce startup time and crystal power dissipation. Care must however be taken that  $C_L$  does not fall outside the crystal pulling range or the circuit may fail to start up altogether. It is also possible to quote  $C_L$  to the crystal manufacturer who can then cut a crystal to order which will resonate, under the specified load conditions, at the desired frequency.

Finally the power dissipation in the crystal must be checked. If  $P_c$  is too high  $C_1$  and  $C_2$  must be reduced. If this is not feasible  $C_2$  alone may be reduced. Unbalancing  $C_1$  and  $C_2$  will, however, require checking if the loop gain condition is still satisfied. This must be done using Equation 1.

Note:  $2 \geq \frac{C_2}{C_1} \geq 0.5$

#### 4.5.1.5 Oscillator/Clock Application Notes

- On the printed circuit board, the tracks to the crystal and capacitors must be made as short as possible. Other signal tracks must not be allowed to cross through this area. The component tracks should preferably be ringed by a ground track connected to the chip ground (0V) on adjacent pins either side of the crystal pins. It is also advisable to provide a ground plane for the circuit to reduce noise.
- External clock signals, applied to  $\overline{XTI}$  and/or XTO, must not exceed the cell supply limits (i.e., 0V and CVdd) and current into or out of  $\overline{XTI}$  and/or XTO must be limited to less than 10mA to avoid damaging the cell's amplitude clamping circuit.
- An external, DC coupled, single ended square wave clock signal may be applied to  $\overline{XTI}$  if OSCMODE = 0. To limit the current taken from the signal source a resistor should be placed between the clock source and  $\overline{XTI}$ . The recommended value for this series resistor is 470  $\Omega$  for a clock signal switching between 0V and CVdd. The current the clock source needs to source/sink is then  $\leq 1.9$  mA. The XTO pin must be left unconnected in this configuration. See Figure 15.
- AC coupling of a single ended external clock to  $\overline{XTI}$ , with OSCMODE = 0, is not recommended. The duty cycle of the

OSCOOUT signal cannot be guaranteed in such a configuration.

- AC coupling of a single ended external clock to  $\overline{\text{XTI}}$ , with OSCMODE = 1, is possible. It is recommended that the circuit shown in Figure 15 be used to correctly bias the oscillator inputs: The common-mode voltage  $V_{CM}$  for  $\overline{\text{XTI}}$  and XTO, (set by the 36 k $\Omega$  and 22 k $\Omega$  resistors) must be in the range 800 mV to CVdd and the amplitude  $V_{pp}$  of the clock signal must be >100 mV. See Figure 15.

Figure 15 - External Clocking

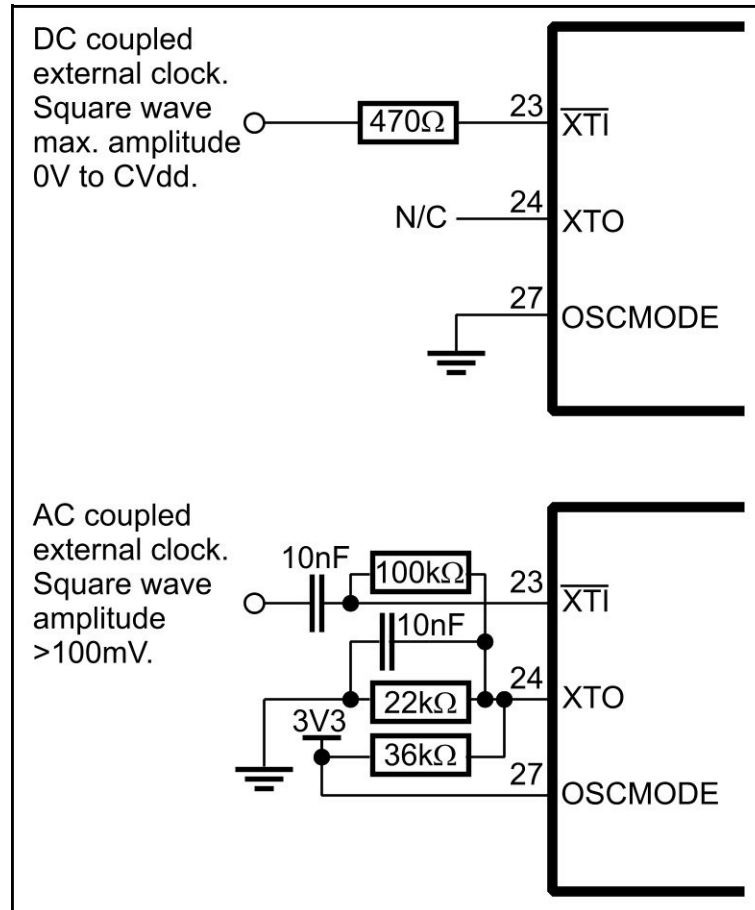

- External, differential clock signals may be applied to  $\overline{\text{XTI}}$  and XTO if OSCMODE = 1. The common-mode voltage  $V_{CM}$  for the differential clock signals must be in the range 800 mV to CVdd, and the peak-to-peak signal amplitude  $V_{pp}$  must be >100 mV. It is recommended that differential clock signals have  $V_{CM} = 1.0V$ . For  $V_{pp} > 400$  mV a resistor of  $\geq 390 \Omega$  in series with  $\overline{\text{XTI}}$  or XTO may be required to limit the current taken from or supplied to the clock sources.

# 5 Application Circuit

Figure 16 - Typical Application Circuit

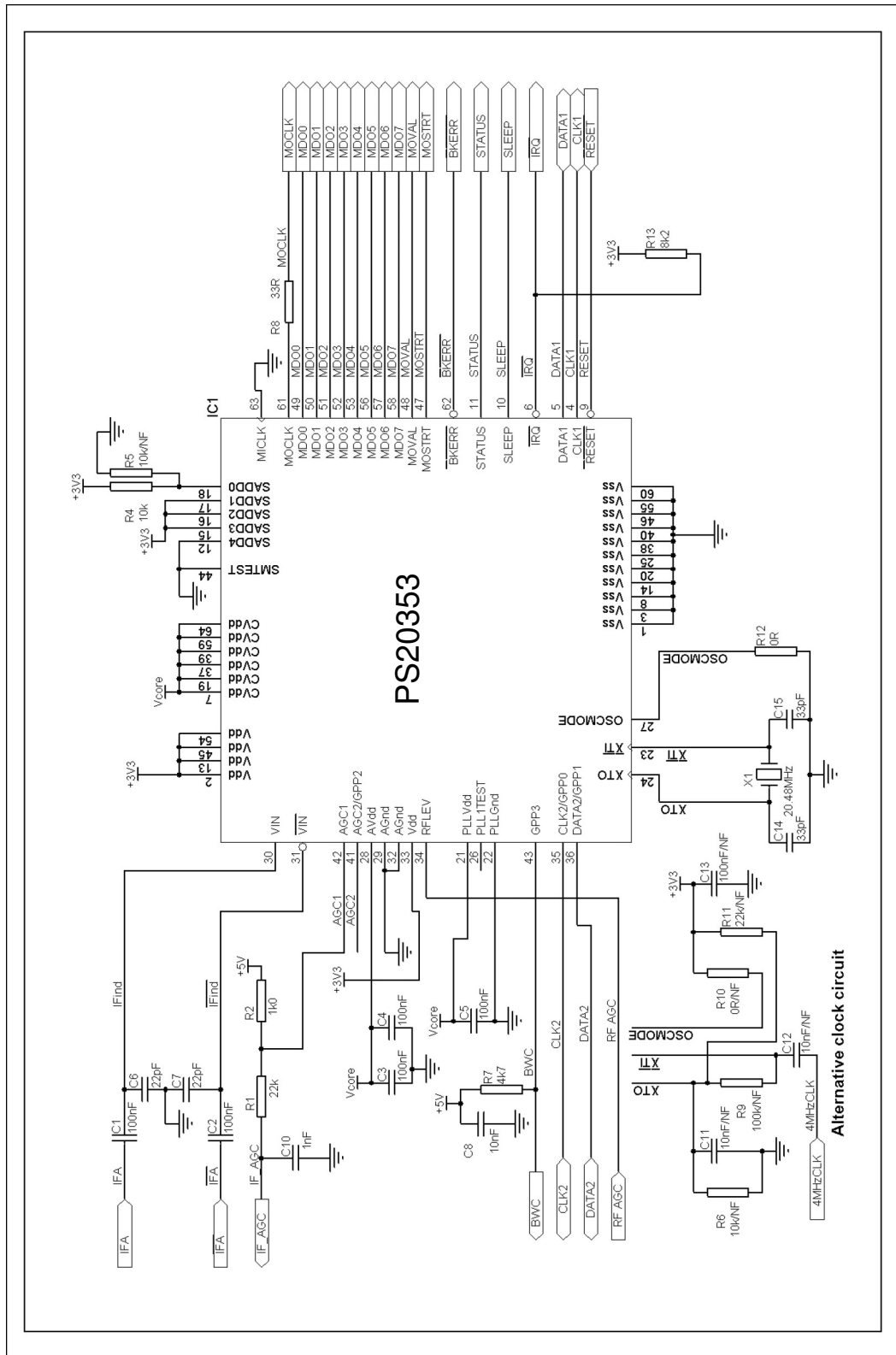



**Plessey Semiconductors Ltd. (Plymouth)**  
Tamerton Road | Roborough | Plymouth  
Devon | United Kingdom | PL6 7BQ

**Phone: +44 1752 693000**  
**Fax: +44 1752 693200**  
**E-Mail: [info@plesseysemiconductors.com](mailto:info@plesseysemiconductors.com)**

**Plessey Semiconductors Ltd.(Swindon)**  
Design & Technology Centre | Delta 500  
Delta Business Park | Great Western Way  
Swindon | United Kingdom | SN5 7XE

**Phone: +44 1793 518000**  
**Fax: +44 1793 518030**  
**E-Mail: [info@plesseysemiconductors.com](mailto:info@plesseysemiconductors.com)**

**For further information about this and other products, please visit:  
[www.plesseysemiconductors.com](http://www.plesseysemiconductors.com)**

#### **Legal Notice**

Product information provided by Plessey Semiconductors Limited ("Plessey") in this document is believed to be correct and accurate. Plessey reserves the right to change/correct the specifications and other data or information relating to products without notice but Plessey accepts no liability for errors that may appear in this document, howsoever occurring, or liability arising from the use or application of any information or data provided herein. Neither the supply of such information, nor the purchase or use of products conveys any licence or permission under patent, copyright, trademark or other intellectual property right of Plessey or third parties.

Products sold by Plessey are subject to its standard Terms and Conditions of Sale that are available on request. No warranty is given that products do not infringe the intellectual property rights of third parties, and furthermore, the use of products in certain ways or in combination with Plessey, or non-Plessey furnished equipments/components may infringe intellectual property rights of Plessey.

The purpose of this document is to provide information only and it may not be used, applied or reproduced (in whole or in part) for any purpose nor be taken as a representation relating to the products in question. No warranty or guarantee express or implied is made concerning the capability, performance or suitability of any product, and information concerning possible applications or methods of use is provided for guidance only and not as a recommendation. The user is solely responsible for determining the performance and suitability of the product in any application and checking that any specification or data it seeks to rely on has not been superseded.

Products are intended for normal commercial applications. For applications requiring unusual environmental requirements, extended temperature range, or high reliability capability (e.g. military, or medical applications), special processing/testing/conditions of sale may be available on application to Plessey.