

GaAs WLAN Dual SPDT Switch 2.4 - 5.8 GHz

Rev. V3

Features

- 802.11a & b/g, UNII, and Hiperlan Applications
- Optimized for 2.4 - 5.8 GHz WLAN
- Low Insertion Loss:
 - 0.85 dB @ 2.4 GHz
 - 1.1 dB @ 5.8 GHz
- High Isolation: 28 dB Typical
- Low Harmonics: <-63 dBc @ 20 dBm
- RoHS* Compliant

Description

The MASW-008206-000DIE is a WLAN GaAs pHEMT MMIC Dual SPDT switch. One SPDT (RF2) is optimized for 2.4 GHz WLAN and the other (RF5) is optimized for 5.8 GHz WLAN applications. Typical applications are for 802.11a and 802.11b/g PC card and access point applications.

The MASW-008206-000DIE delivers high isolation, low insertion loss, and high linearity up to 5.8 GHz. This device is fabricated using a 0.5 micron gate length GaAs pHEMT process. The process features full passivation for performance and reliability.

Ordering Information ¹

Part Number	Package
MASW-008206-000DIE	Separated Die on Grip Ring

1. Die quantity varies.

Die Bond Pad Layout

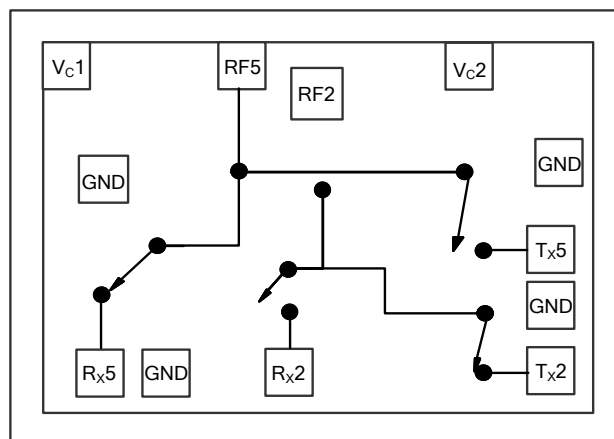

Die Bond Pad Configuration

Pad No.	Name	Description
1	V _c 1	Voltage Control 1
2	GND	Ground
3	R _x 5	5 GHz R _x Port
4	GND	Ground
5	R _x 2	2.4 GHz R _x Port
6	T _x 2	2.4 GHz T _x Port
7	GND	Ground
8	T _x 5	5 GHz T _x Port
9	GND	Ground
10	V _c 2	Voltage Control 2
11	RF2	2.4 GHz Antenna Port
12	RF5	5 GHz Antenna Port

* Restrictions on Hazardous Substances, European Union Directive 2002/95/EC.

GaAs WLAN Dual SPDT Switch 2.4 - 5.8 GHz

Rev. V3

Electrical Specifications^{2,3}: $T_A = 25^\circ\text{C}$, $Z_0 = 50\ \Omega$, $V_C = 0\text{V} / 3\text{V}$, $P_{IN} = 0\ \text{dBm}$

Parameter	Test Conditions	Units	Min.	Typ.	Max.
Insertion Loss	RF2 to Tx2/Rx2, 2.4 GHz RF5 to Tx5/Rx5, 5.0 GHz	dB	—	0.85 1.1	1.0 1.2
Isolation	RF2 to Tx2/Rx2, 2.4 GHz RF5 to Tx5/Rx5, 5.0 GHz	dB	25.5 21.0	30.0 25.0	— —
Return Loss	DC - 6.0 GHz	dB	—	15	—
IP3	20 dBm Total Power, 1 MHz Spacing RF2 to Tx2/Rx2, 2.4 GHz RF5 to Tx5/Rx5, 4.9 GHz	dBm	— —	54 55	— —
Input P1dB	RF2 to Tx2, 2.4-2.5 GHz RF5 to Tx5, 4.9-5.9 GHz	dBm	— —	28 28	— —
Harmonics	RF2 to Tx2, 2.4-2.5 GHz, 20 dBc RF5 to Tx5, 4.9-5.9 GHz, 20 dBc	dBc	— —	-63 -67	— —
Control Current	$ V_C = 3\ \text{V}$	μA	—	<1	10.0
T_{RISE} / T_{FALL}	10% - 90% RF, 90% - 10% RF	ns	—	22	—
T_{ON} / T_{OFF}	50% Control - 90% RF, 50% Control - 10% RF	ns	—	30	—

2. External blocking capacitors on all RF ports.

3. Electrical min/max are guaranteed in die form only.

Absolute Maximum Ratings^{4,5}

Parameter	Absolute Maximum
Input Power @ 3 V Control @ 5 V Control	+32 dBm +33 dBm
Operating Voltage	+8 volts
Operating Temperature	-40°C to +85°C
Storage Temperature	-65°C to +150°C

4. Exceeding any one or combination of these limits may cause permanent damage to this device.

5. M/A-COM Technology Solutions does not recommend sustained operation near these survivability limits.

Qualification

Qualified to M/A-COM specification REL-201, Process Flow -2.

Truth Table^{6,7,8}

Control V_{C1}	Control V_{C2}	RF2 - Tx2 RF5 - Rx5	RF2 - Rx2 RF5 - Tx5
1	0	On	Off
0	1	Off	On

6. For positive voltage control, external DC blocking capacitors are required on all RF ports.

7. Differential voltage, V (state 1) - V (state 0), must be +2.7 V minimum and must not exceed +5 V.

8. 0 = $0 \pm 0.3\ \text{V}$, 1 = +2.7 V to +5 V.

Handling Procedures

Please observe the following precautions to avoid damage:

Static Sensitivity

Gallium Arsenide Integrated Circuits are sensitive to electrostatic discharge (ESD) and can be damaged by static electricity. Proper ESD control techniques should be used when handling these Class Zero (100 V) devices.

Typical Performance Curves: 2.4-2.5 GHz (plots = chip on board assembly)

T_X Insertion Loss

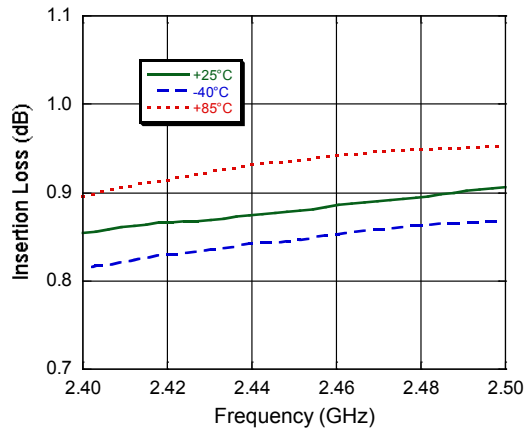

R_X Insertion Loss

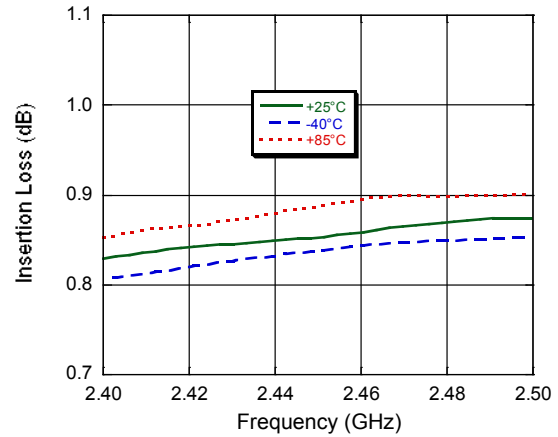

T_X Isolation

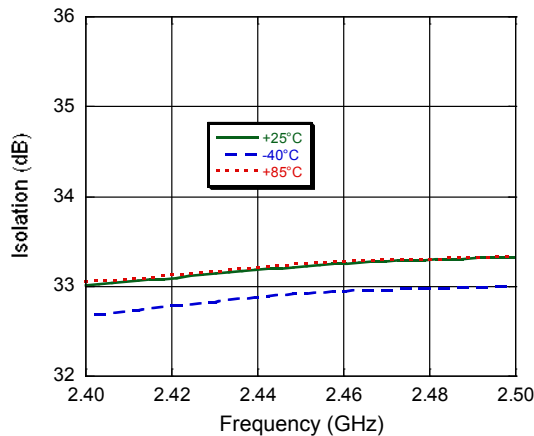

R_X Isolation

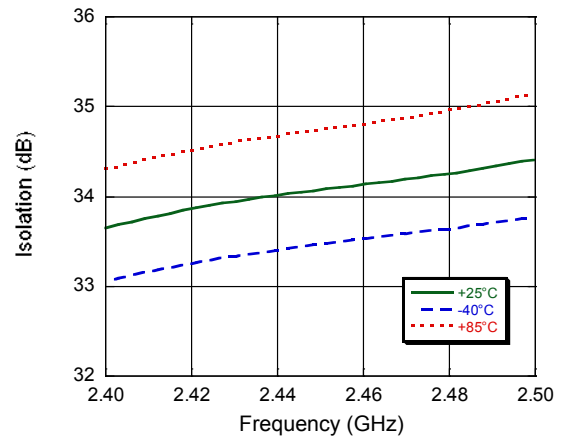

Typical Performance Curves: 4.8-6.0 GHz (plots = chip on board assembly)

T_x Insertion Loss

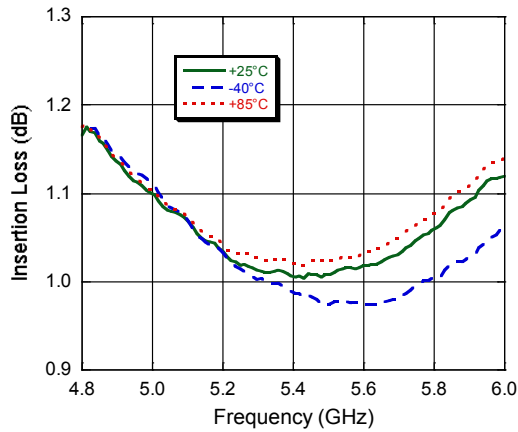

R_x Insertion Loss

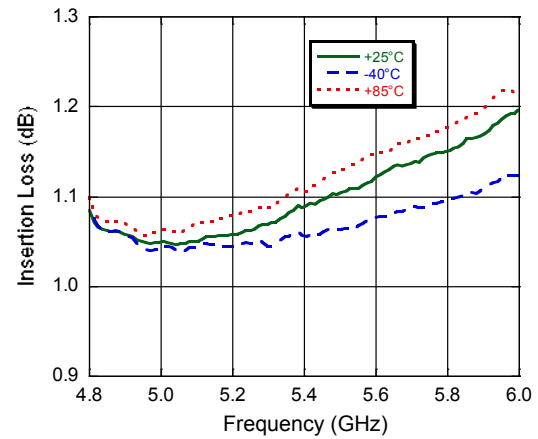

T_x Isolation

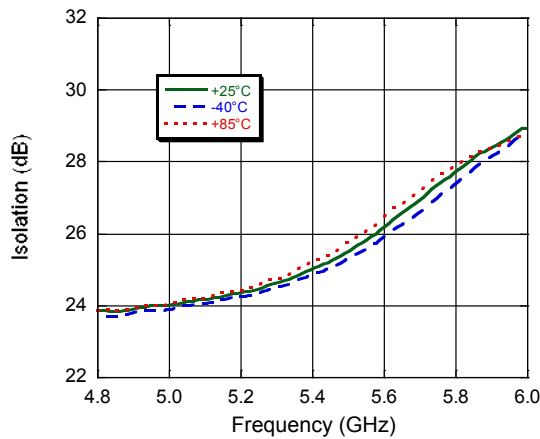

R_x Isolation

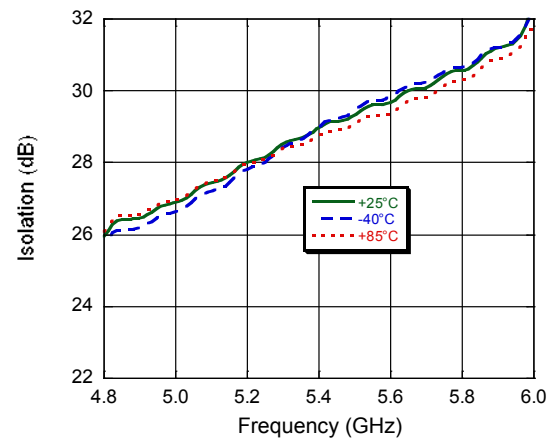

Outline Drawing

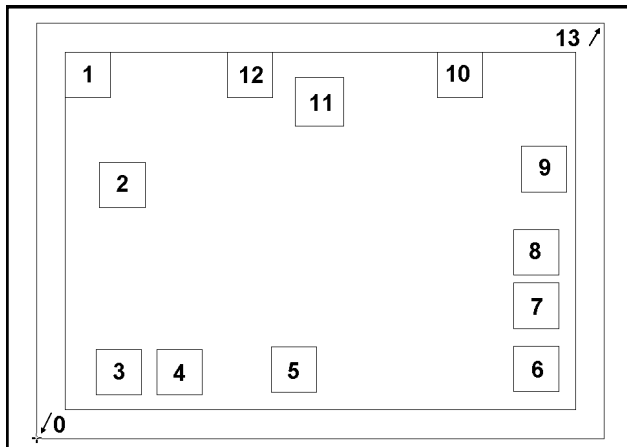

Chip mounted to PWB for testing purposes

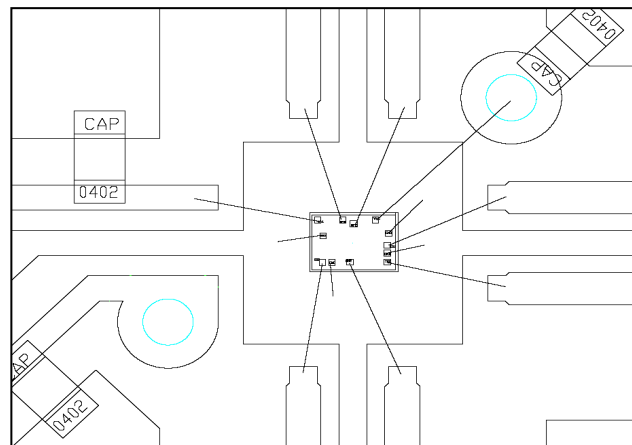

Pad Configuration ⁹

Die Size: 890 x 650 μm (nominal)

Die Thickness: 6 mils (nominal)

Pad No.	X (μm) nominal	Y (μm) nominal	Pad Size (μm)
0	0	0	Lower left edge of die
1	80.5	569.5	71 x 71
2	134.5	397	71 x 71
3	129	104	71 x 71
4	224	104	71 x 71
5	403.75	108	71 x 71
6	783.5	109	71 x 71
7	783.5	208	71 x 71
8	783.5	292	71 x 71
9	795.25	421.75	71 x 71
10	664	569.5	71 x 71
11	443	527	76 x 76
12	334.75	569.5	71 x 71
13	890	650	Upper right edge of die

9. All X,Y dimensions are at bond pad center.

Application Schematic

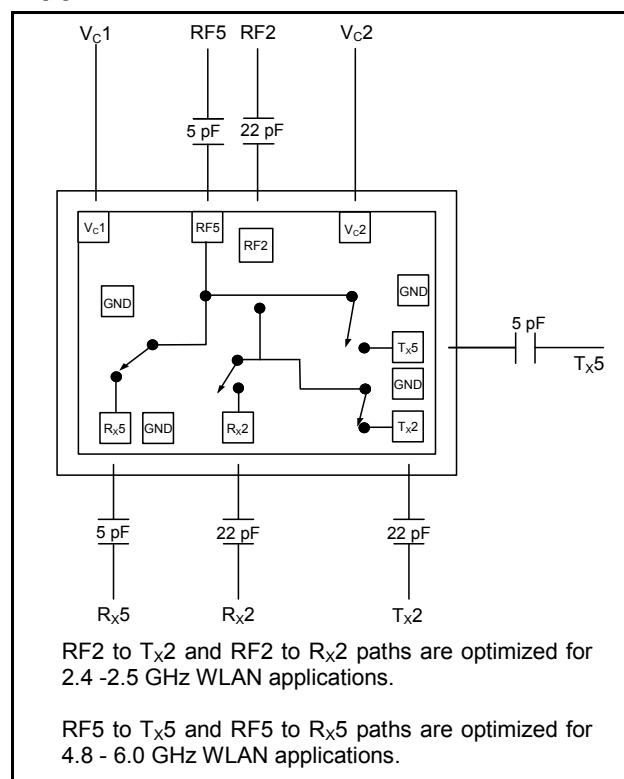

M/A-COM Technology Solutions Inc. All rights reserved.

Information in this document is provided in connection with M/A-COM Technology Solutions Inc ("MACOM") products. These materials are provided by MACOM as a service to its customers and may be used for informational purposes only. Except as provided in MACOM's Terms and Conditions of Sale for such products or in any separate agreement related to this document, MACOM assumes no liability whatsoever. MACOM assumes no responsibility for errors or omissions in these materials. MACOM may make changes to specifications and product descriptions at any time, without notice. MACOM makes no commitment to update the information and shall have no responsibility whatsoever for conflicts or incompatibilities arising from future changes to its specifications and product descriptions. No license, express or implied, by estoppel or otherwise, to any intellectual property rights is granted by this document.

THESE MATERIALS ARE PROVIDED "AS IS" WITHOUT WARRANTY OF ANY KIND, EITHER EXPRESS OR IMPLIED, RELATING TO SALE AND/OR USE OF MACOM PRODUCTS INCLUDING LIABILITY OR WARRANTIES RELATING TO FITNESS FOR A PARTICULAR PURPOSE, CONSEQUENTIAL OR INCIDENTAL DAMAGES, MERCHANTABILITY, OR INFRINGEMENT OF ANY PATENT, COPYRIGHT OR OTHER INTELLECTUAL PROPERTY RIGHT. MACOM FURTHER DOES NOT WARRANT THE ACCURACY OR COMPLETENESS OF THE INFORMATION, TEXT, GRAPHICS OR OTHER ITEMS CONTAINED WITHIN THESE MATERIALS. MACOM SHALL NOT BE LIABLE FOR ANY SPECIAL, INDIRECT, INCIDENTAL, OR CONSEQUENTIAL DAMAGES, INCLUDING WITHOUT LIMITATION, LOST REVENUES OR LOST PROFITS, WHICH MAY RESULT FROM THE USE OF THESE MATERIALS.

MACOM products are not intended for use in medical, lifesaving or life sustaining applications. MACOM customers using or selling MACOM products for use in such applications do so at their own risk and agree to fully indemnify MACOM for any damages resulting from such improper use or sale.