

Super-mini Signal Conditioners Mini-M Series

using 'One-Step-Cal' Calibration. PC Configurator is also available.)

RTD TRANSMITTER

(field- and PC-configurable)

Functions & Features

- Accepts direct input from an RTD and provides a standard process signal
- Easy 'One-Step Cal' calibration using the front three control buttons without needing a PC; PC software is also usable.
- Input range, output type and range are configurable

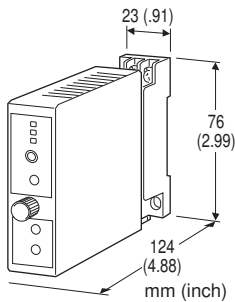

[2] OUTPUT

Current

Z1: Range 0 – 20 mA DC

Voltage

V1: Range -2.5 – +2.5 V DC

V2: Range -10 – +10 V DC

Output ranges are fully programmable out of the range specified when ordering by setting up the DIP switch and using 'One-Step-Cal' Calibration. PC Configurator is also available.

POWER INPUT

AC Power

M: 85 – 264 V AC (Operational voltage range 85 – 264 V, 47 – 66 Hz)

[3] OPTIONS

blank: none

/Q: With options (specify the specification)

MODEL: M2LR-[1][2]-M[3]

ORDERING INFORMATION

- Code number: M2LR-[1][2]-M[3]
- Specify a code from below for each [1] through [3]. (e.g. M2LR-4Z1-M/Q)
- Temperature range (e.g. 0 – 100°C)
- Output range (e.g. 4 – 20 mA DC)
- Specify the specification for option code /Q (e.g. /C01/S01)

[1] INPUT RTD (2- or 3-wire)

1: JPt 100 (JIS'89)

(Usable range: -200 to +500°C, -328 to +932°F; min.span: 20°C, 36°F)

3: Pt 100 (JIS'89)

(Usable range: -200 to +650°C, -328 to +1202°F; min.span: 20°C, 36°F)

4: Pt 100 (JIS'97, IEC)

(Usable range: -200 to +850°C, -328 to +1562°F; min.span: 20°C, 36°F)

5: Pt 50 Ω (JIS'81)

(Usable range: -200 to +649°C, -328 to +1200°F; min.span: 20°C, 36°F)

7: Pt 1000

(Usable range: -200 to +850°C, -328 to +1562°F; min.span: 20°C, 36°F)

9: Cu 10 @25°C

(Usable range: -50 to +250°C, -58 to +482°F; min.span: 20°C, 36°F)

(Consult M-System for users' tables.)

(Input range are fully programmable out of the range specified when ordering by setting up the DIP switch and

SPECIFICATIONS OF OPTION: Q (multiple selections)

COATING (For the detail, refer to M-System's web site.)

/C01: Silicone coating

/C02: Polyurethane coating

/C03: Rubber coating

TERMINAL SCREW MATERIAL

/S01: Stainless steel

RELATED PRODUCTS

- PC configurator software (model: M2LRCFG)

Downloadable at M-System's web site.

A dedicated cable is required to connect the module to the PC. Please refer to the internet software download site or the users manual for the PC configurator for applicable cable types.

GENERAL SPECIFICATIONS

Construction: Plug-in

Connection: M3 screw terminals (torque 0.8 N·m)

Screw terminal: Chromated steel (standard) or stainless steel

Housing material: Flame-resistant resin (black)

Isolation: Input to output to power

Overrange output: Approx. -15 to +115 %

Zero adjustment: -15 to +15 % (front)

Span adjustment: 85 to 115 % (front)

Burnout protection: Upscale, downscale or no burnout

selectable with DIP switches

Status indicator LED: Tri-color (green/amber/red) LED; Blinking patterns indicate operation status of the transmitter.

Configuration

'One-Step Cal' calibration: With I/O type and the full-scale range configured via the side DIP switches, precise 0 % and 100 % ranges are calibrated via the front control buttons with a help of LED.

PC configurator: Via Windows PC connected to the front jack.

Programmable features include:

- I/O type and range
- Zero and span adjustments
- Burnout
- User's linearization table

Configurator connection: 2.5 dia. miniature jack; RS-232-C level

INPUT SPECIFICATIONS

Maximum leadwire resistance: 20 Ω per wire (3-wire)

Sensing current: ≤ 1.2 mA

If not specified, the input range is 100°C.

OUTPUT SPECIFICATIONS

■ DC Current

Maximum range: 0 - 20 mA DC

Conformance range: 0 - 24 mA DC

Minimum span: 1 mA

Offset: Lower range can be any specific value within the output range provided that the minimum span is maintained.

Load resistance: Output drive 12 V max.
(e.g. 4 - 20 mA: 600 Ω [12 V ÷ 20 mA])

If not specified, the output range is 4 - 20 mA DC.

■ DC Voltage

Code V1 (narrow spans)

Conformance range: -3 - +3 V DC

Output range: -2.5 - +2.5 V DC

Minimum span: 250 mV

Code V2 (wide spans)

Conformance range: -11.5 - +11.5 V DC

Output range: -10 - +10 V DC

Minimum span: 1 V

Offset: Lower range can be any specific value within the output range provided that the minimum span is maintained.

Load resistance: Output drive 1 mA max.
(e.g. 1 - 5 V: 5000 Ω [5 V ÷ 1 mA])

If not specified, the output range is shown below.

V1: 0 - 1 V DC

V2: 1 - 5 V DC

INSTALLATION

Power Consumption

• AC:

Approx. 4 VA at 100 V

Approx. 5 VA at 200 V

Approx. 6 VA at 264 V

Operating temperature: -5 to +55°C (23 to 131°F)

Operating humidity: 30 to 90 %RH (non-condensing)

Mounting: Surface or DIN rail

Weight: 120 g (0.26 lb)

PERFORMANCE

Overall accuracy: Input accuracy + output accuracy
Inversely proportional to the span.

See CALCULATION EXAMPLES OF OVERALL ACURACY.

• Input accuracy: (whichever is greater)

±0.1 % of FS or ±0.15°C (Pt and JPt)

±0.1 % of FS or ±1°C (Cu 10)

• Output accuracy: ±0.04 % of max. output range

Temp. coefficient: ±0.015 %/°C (±0.008 %/°F) of max. span

Response time: ≤ 1 sec. (0 - 90 %)

Burnout response time: ≤ 1 sec.

Line voltage effect: ±0.1 % over voltage range

Insulation resistance: ≥ 100 MΩ with 500 V DC

Dielectric strength: 2000 V AC @1 minute (input to output to power to ground)

CALCULATION EXAMPLES OF OVERALL ACCURACY

[Example] Pt 100, 0 - 100°C, Output Type -10 - +10 V,
Output Range 1 - 5 V

Input Accuracy* (0.15°C**) ÷ Span (100°C) × 100 %
+ Max. Output Range (20 V) ÷ Span (4 V) × 0.04 %
= ±0.35 %

*Calculate the accuracy in °C.

**100°C × 0.1 % = 0.1°C ≤ 0.15°C. 0.15°C is used as input accuracy value.

EXTERNAL VIEW

FRONT VIEW

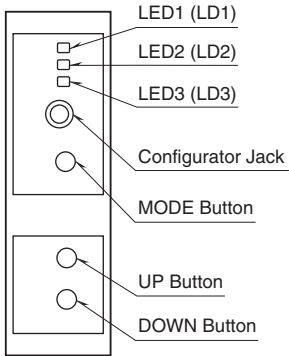

SIDE VIEW

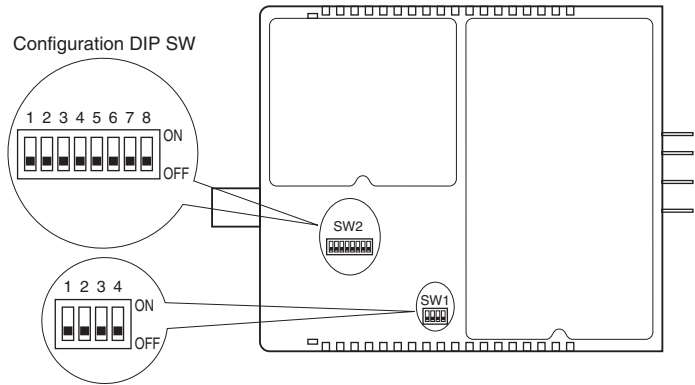

For detailed information on the configuration and calibration, refer to the instruction manual.

EXTERNAL DIMENSIONS & TERMINAL ASSIGNMENTS unit: mm (inch)

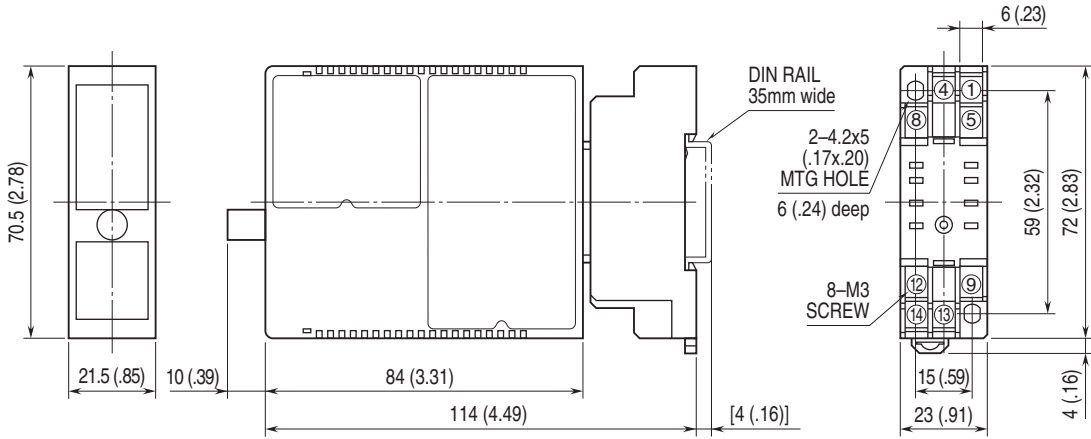

• When mounting, no extra space is needed between units.

SCHEMATIC CIRCUITRY & CONNECTION DIAGRAM

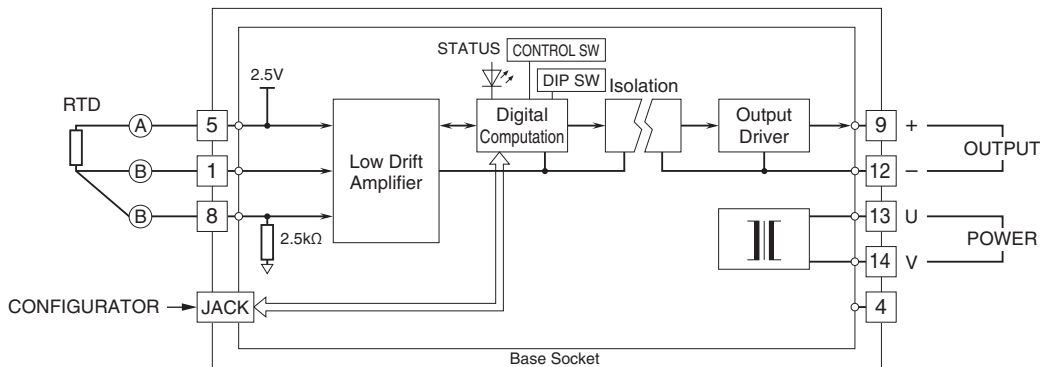

Specifications are subject to change without notice.