

PAD	CONNECTION
1	Crystal
2	Ground & lid
3	Crystal
4	Ground & lid

Features

- ▶ AEC-Q200 qualified for automotive apps
- ▶ Seam sealed for excellent long-term stability
- ▶ High reliability at low cost
- ▶ Metal lid can be grounded to minimise EMI

Example Applications

- ▶ Vehicle telematics
- ▶ Connected car
- ▶ Remote Keyless Entry (RKE)
- ▶ Audio - DAB / Bluetooth
- ▶ Camera

Specifications

Parameters	Product	Option Codes
	GRX-530	
Frequency range:	9.80 ~ 40.0MHz	■
Calibration tolerance:	±10ppm ±15ppm ±20ppm Other values	□ ■ □ □
Temperature stability:	±15ppm ±20ppm ±50ppm ±100ppm Other values	□ □ □ □ □
Operating temperature range:	-40 to +85°C -40 to +125°C Other values	□ □ □
Storage temperature range:	-40 to +125°C	■
Circuit condition:	10pF 12pF 16pF 20pF Other values	□ □ □ □ □
Oscillation mode:	Fundamental	■
Static capacitance (C ₀):	5pF max	■
Equivalent series resistance (max):	60Ω (9.80 ~ 10.99MHz) 50Ω (11.0 ~ 11.99MHz) 40Ω (12.0 ~ 24.99MHz) 30Ω (25.0 ~ 40.0MHz)	■ ■ ■ ■
Ageing:	±3ppm max first year	■
Test drive level:	10μW typ, 100μW max	■
Soldering condition:	260°C, 10 sec x2 max	■

■ Standard. □ Optional - Please specify required code(s) when ordering

Ordering Information

Product name + option codes + frequency



eg: **GRX-530/P24DF 13.560MHz** 15/20/-40+85/16-F

GRX-530/25ABF 27.0MHz 20/50/-40+125/12-F

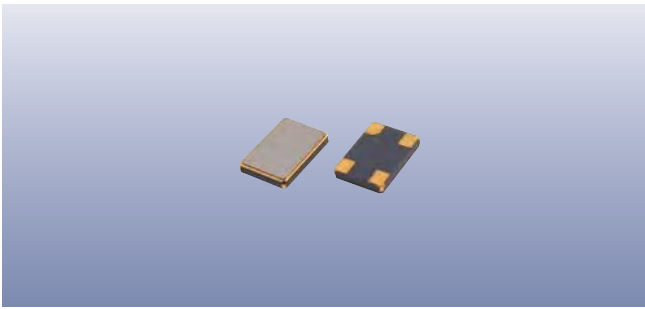
Option code X (eg GRX-530/X) denotes a custom specification.



Construction

-  Ceramic body with gold-plated pads
-  Metal lid, seam sealed

Composition



This product is lead-free, and is fully compliant with the RoHS directive 2011/65/EU



Packaging & Handling

Production quantities supplied on T&R, 1k pcs per reel.
Small quantities may be supplied on tape (no reel), or in bulk.

Marking

FREQUENCY
S DC

Marking type: Laser
DC = Date code in YM, eg "EB" = Feb 2015

	A	B	C	D	E	F	G	H	J	K	L	M
Y	1	2	3	4	5	6	7	8	9	0		
M	Jan	Feb	Mar	Apr	May	Jun	Jul	Aug	Sep	Oct	Nov	Dec

Tape & Reel Specification

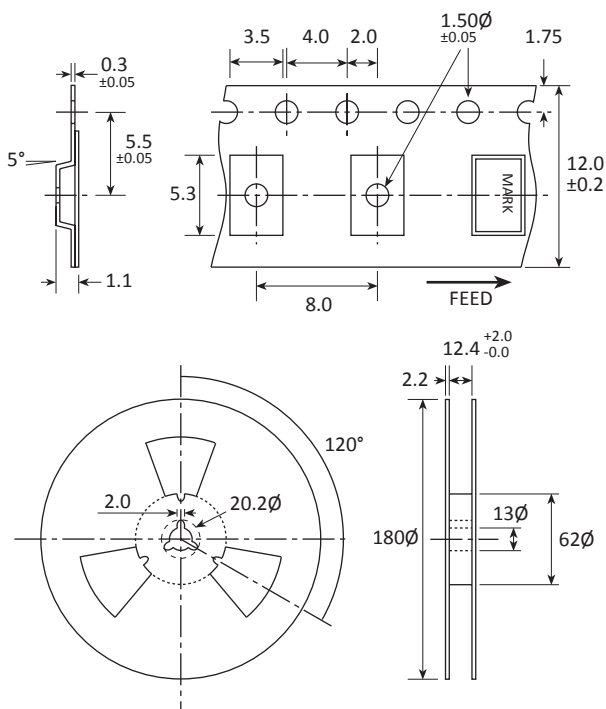

Not to scale. Dimensional tolerances ±0.1mm unless otherwise stated.

Soldering Profile

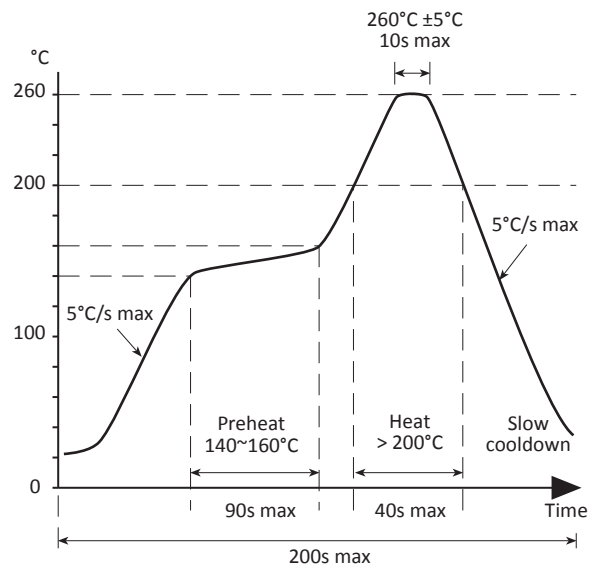

Maximum solder resistance: 260°C x 10 secs x 2.