

## Top View LEDs

### 67-11-BUTT-JM0JL0V1AAH7C-2T8-AM(SV)



#### Features

##### Lead (Pb) Free Product - RoHS Compliant

- P-LCC-2 package.
- Colorless clear resin.
- Wide viewing angle 120°.
- Inner reflector and white package.
- Brightness: 710 to 1400 mcd at 10 mA
- Precondition: Bases on JEDEC J-STD 020D Level 3
- Qualification according to AEC-Q101 revs C.
- Automotive reflow profile (IR reflow or wave soldering)
- Compliance with EU REACH
- Compliance Halogen Free (Br<900 ppm ,Cl <900 ppm, Br+Cl <1500 ppm)

#### Applications

- Automotive backlighting or indicator: Interior and exterior lighting, dashboard, switch, reading lamp, audio and video equipments...etc.
- Backlight: LCD, switches, symbol, mobile phone and illuminated advertising.
- Display for indoor and outdoor application.
- Ideal for coupling into light guides.
- Substitution of traditional light.
- Optical indicator.
- General applications.

## Device Selection Guide

Chip Materials	Emitted Color	Resin Color
InGaN	White	Yellowish

## Absolute Maximum Ratings (Ta=25°C)

Parameter	Symbol	Rating	Unit
Reverse Voltage	$V_R$	5	V
Forward Current	$I_F$	30	mA
Power Dissipation	$P_d$	105	mW
Junction Temperature	$T_j$	125	°C
Operating Temperature	$T_{opr}$	-40 ~ +100	°C
Storage Temperature	$T_{stg}$	-40 ~ +110	°C
Thermal Resistance	$R_{th\ J-A}$	250	K/W
	$R_{th\ J-S}$	150	K/W
ESD (Classification acc. AEC Q101)	$ESD_{HBM}$	2000	V
	$ESD_{MM}$	200	V
Soldering Temperature	$T_{sol}$	Reflow Soldering : 260 °C for 30 sec. Hand Soldering : 350 °C for 3 sec.	

### Electro-Optical Characteristics (Ta=25°C)

Parameter	Symbol	Min.	Typ.	Max.	Unit	Condition
Luminous Intensity	I <sub>v</sub>	710	-----	1400	mcd	I <sub>F</sub> =10mA
Viewing Angle	2θ <sub>1/2</sub>	-----	120	-----	deg	I <sub>F</sub> =10mA
Forward Voltage	V <sub>F</sub>	2.6	----	3.5	V	I <sub>F</sub> =10mA
Reverse Current	I <sub>R</sub>	-----	-----	2	μA	V <sub>R</sub> =5V

Note:

1. Tolerance of Luminous Intensity: ±8%
2. Tolerance of Forward Voltage: ±0.05V

### Bin Range of Luminous Intensity

Bin Code	Min.	Max.	Unit	Condition
V1	710	900	mcd	I <sub>F</sub> =10mA
V2	900	1120		
AA	1120	1400		

Note:

Tolerance of Luminous Intensity: ±8%

**Bin Range of Chromaticity Coordinates**

Bin Code	CIE x	CIE y	Condition
JM0	0.2848	0.2757	I <sub>F</sub> =10mA
	0.2780	0.2883	
	0.2922	0.3077	
	0.2971	0.2935	
JL0	0.2898	0.2664	
	0.2848	0.2757	
	0.2971	0.2935	
	0.3007	0.2830	

Note:  
 Tolerance of Chromaticity Coordinates: ±0.005

**The C.I.E. 1931 Chromaticity Diagram**

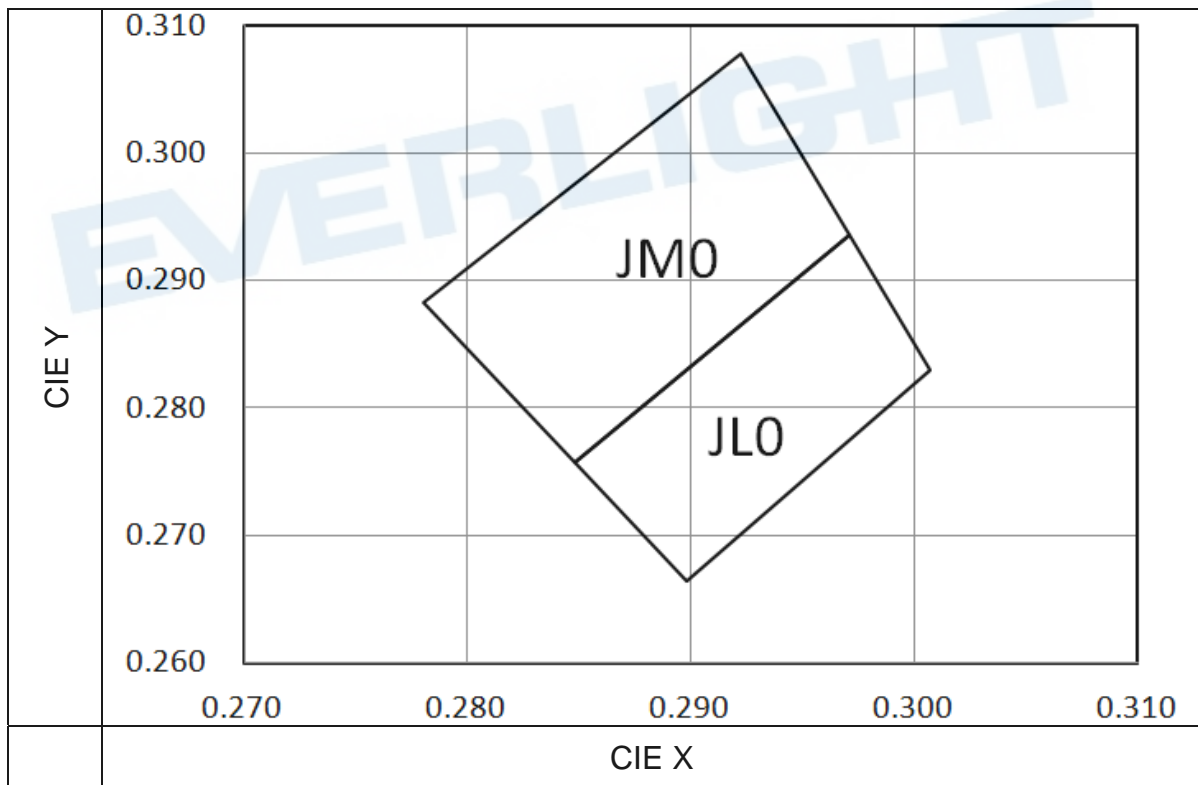

## Typical Electro-Optical Characteristics Curves

### Typical Curve of Spectral Distribution

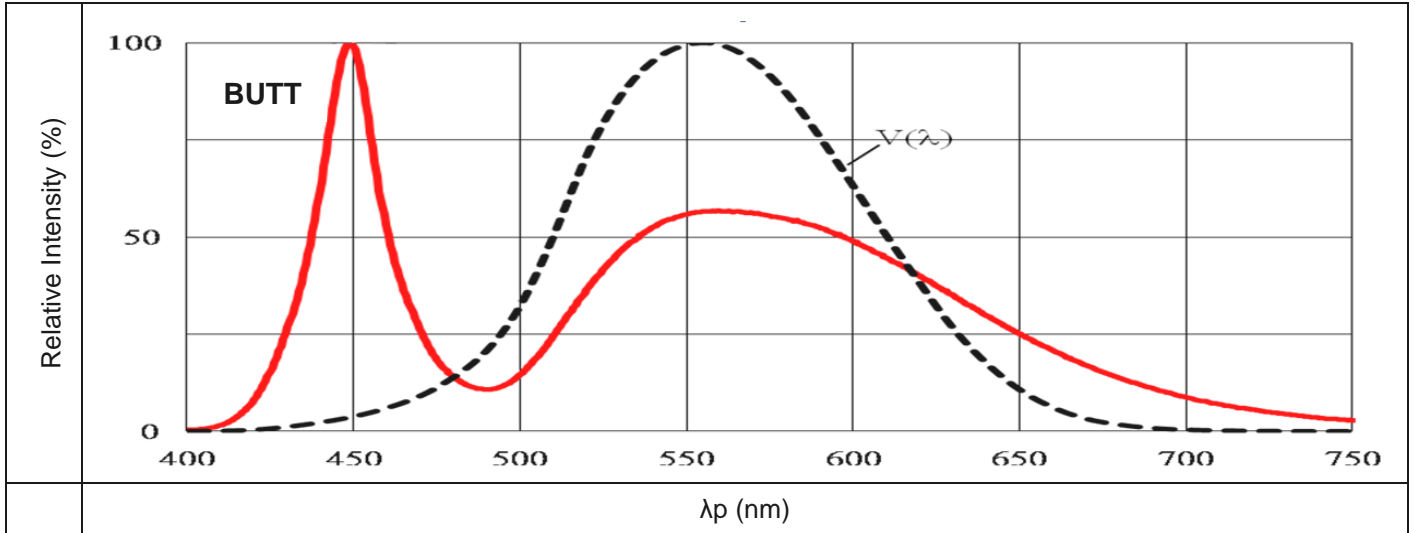

Note:  $V(\lambda)$ =Standard eye response curve;

### Diagram Characteristics of Radiation

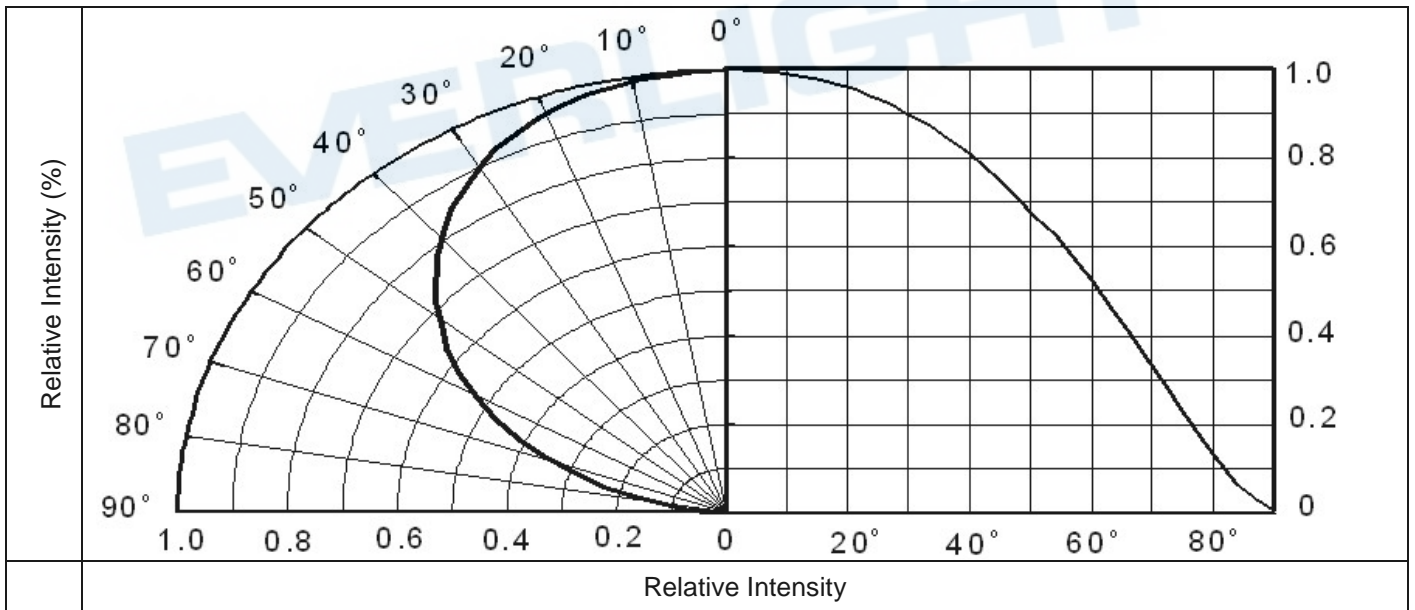

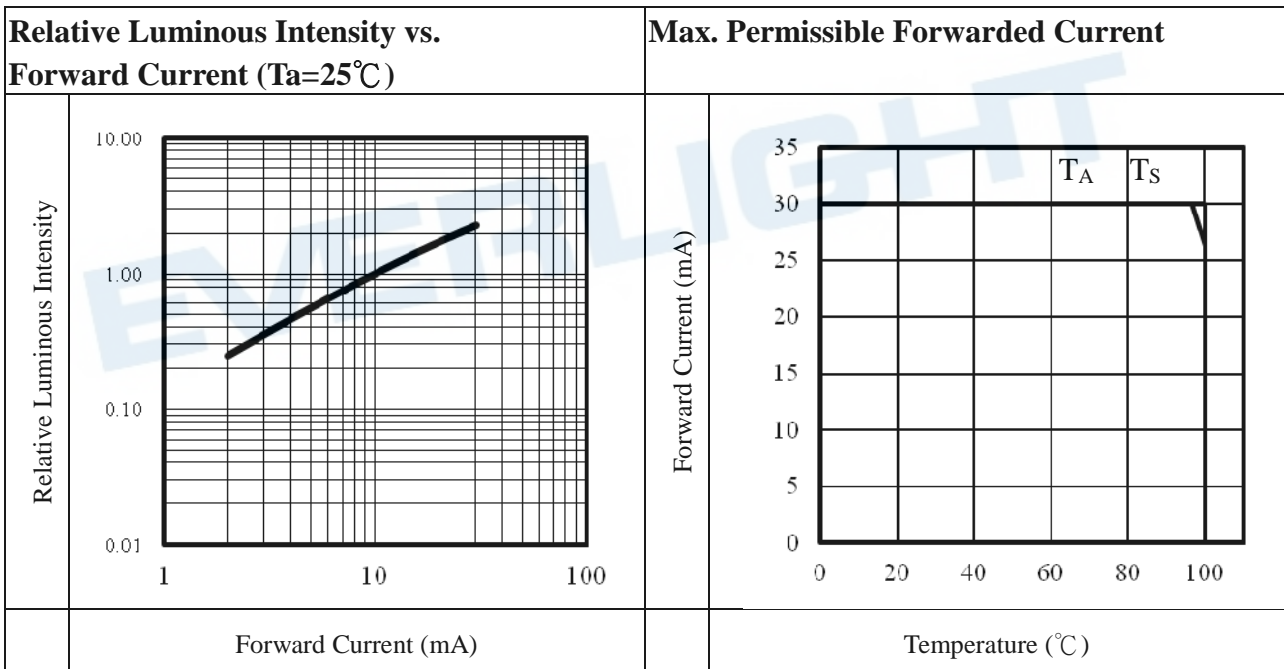
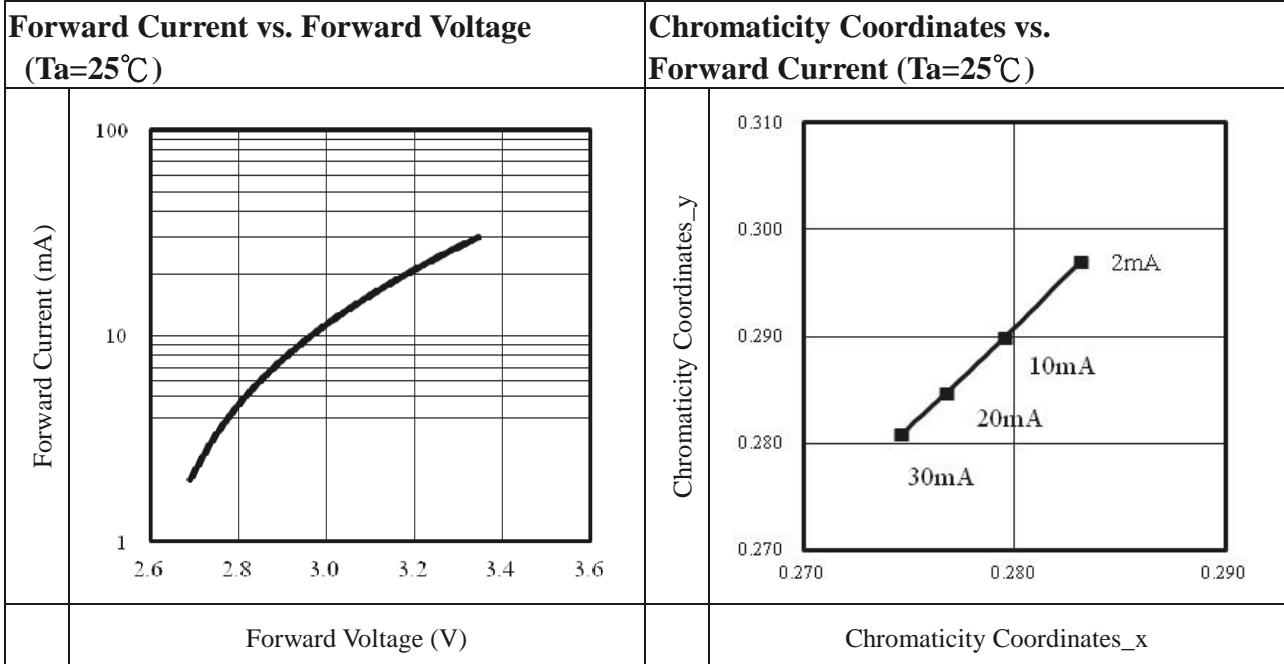

### Package Dimension

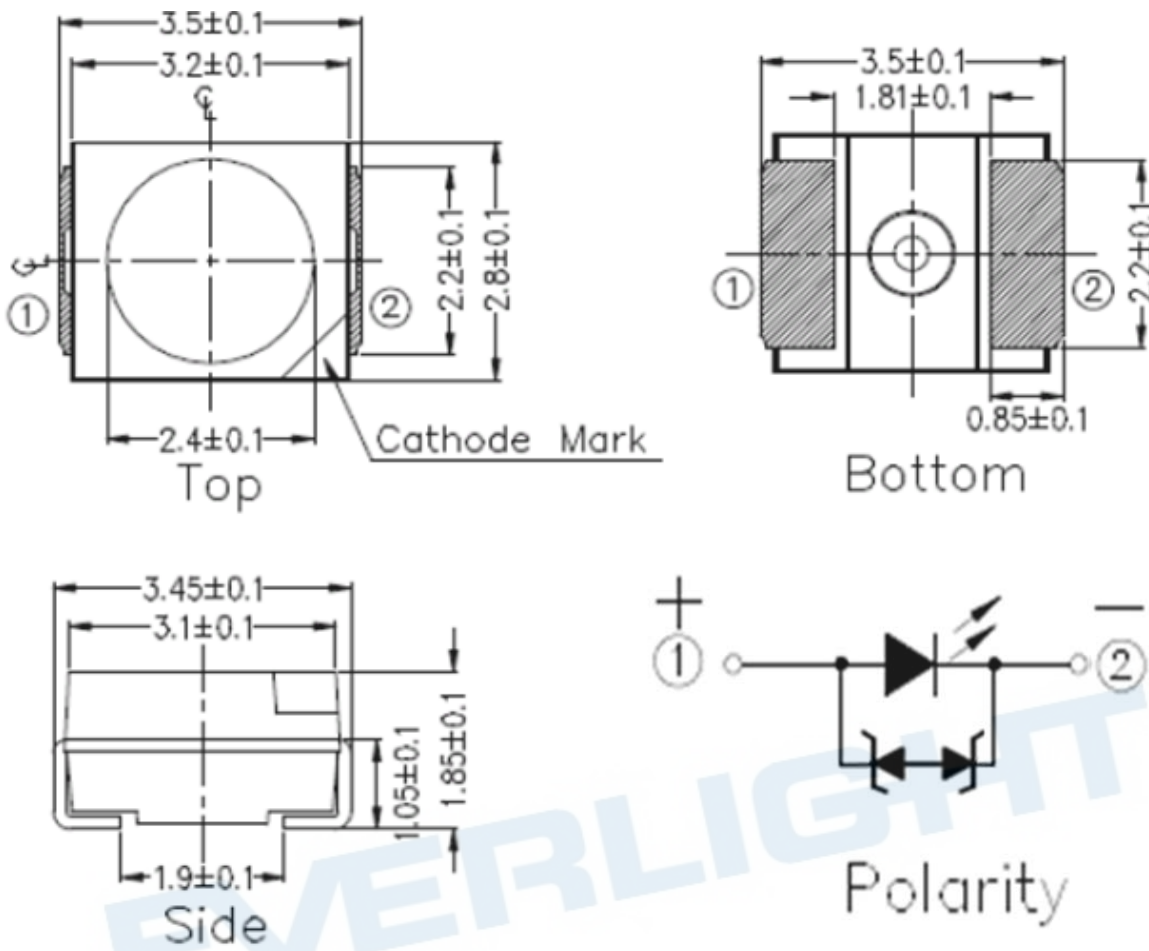

Note: Tolerances unless mentioned  $\pm 0.05$ mm. Unit = mm

Moisture Resistant Packing Materials

Label Explanation

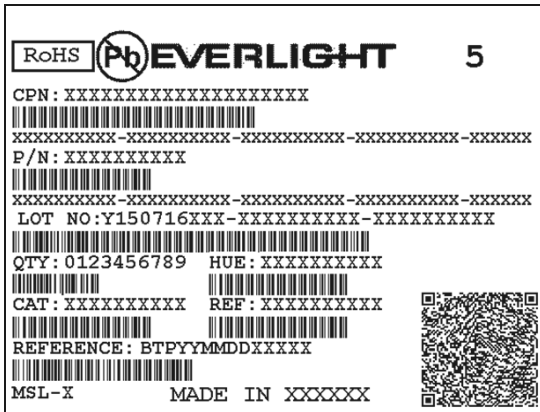

- CPN: Customer's Product Number
- P/N: Product Number
- QTY: Packing Quantity
- CAT: Luminous Intensity Rank
- HUE: Dom. Wavelength Rank
- REF: Forward Voltage Rank
- LOT No: Lot Number

Reel Dimensions

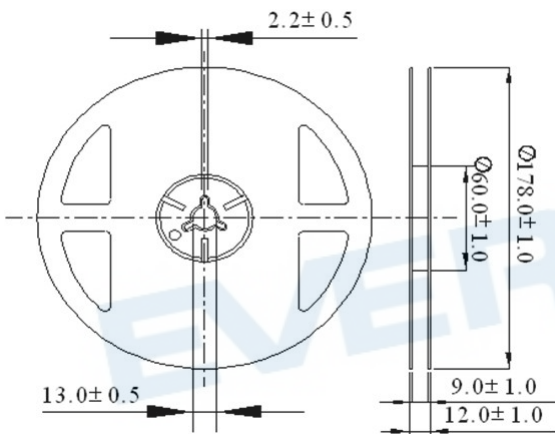

Carrier Tape Dimensions: Loaded Quantity 2000 pcs Per Reel

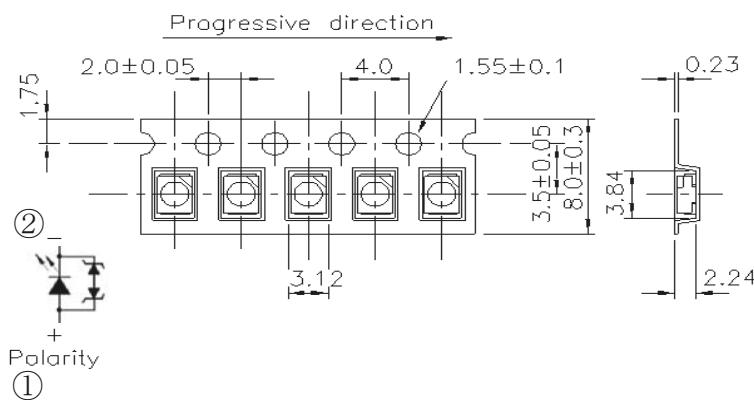

Note: Tolerances unless mentioned  $\pm 0.1$ mm. Unit = mm



**Moisture Resistant Packing Process**

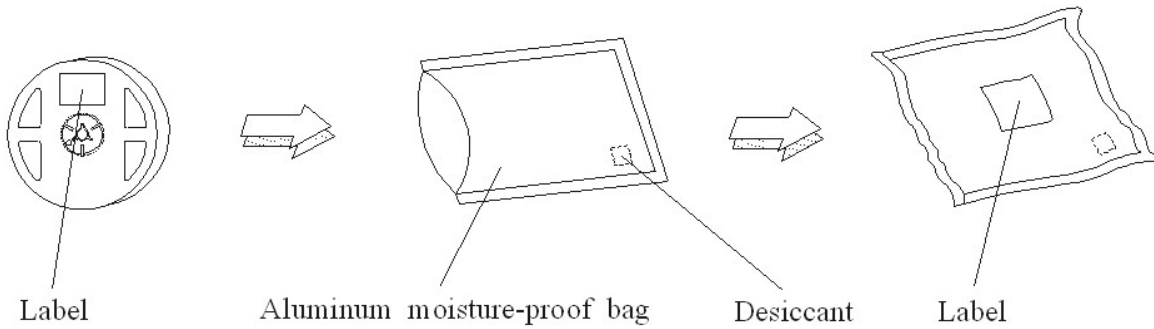

Note: Tolerances unless mentioned  $\pm 0.1\text{mm}$ . Unit = mm

**Precautions for Use**

1. Soldering Condition

1.1 (A) Maximum Body Case Temperature Profile for evaluation of Reflow Profile

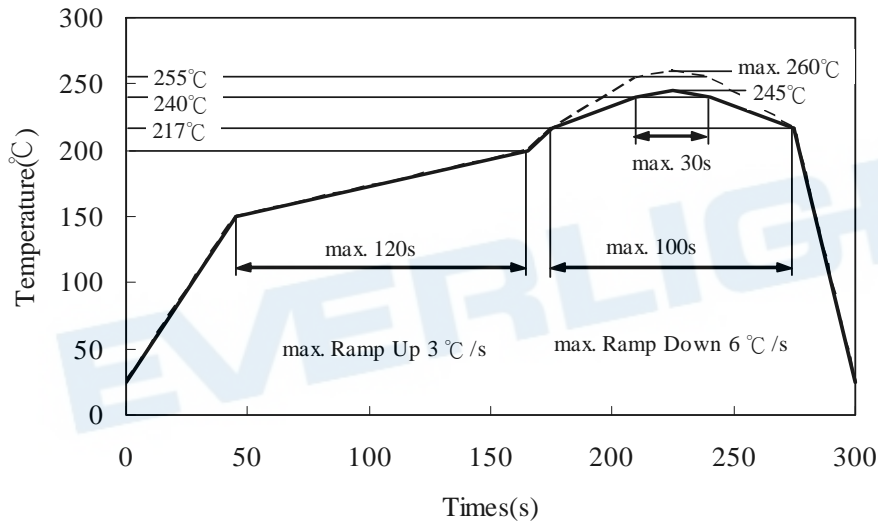

1.2 (B) Recommend soldering pad

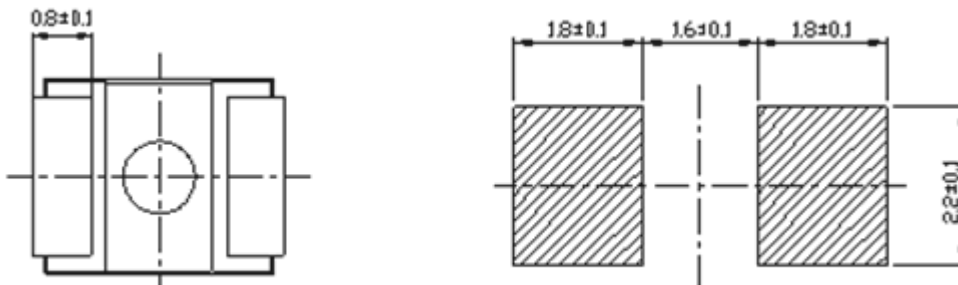

Note: Tolerances unless mentioned  $\pm 0.1\text{mm}$ . Unit = mm

## 2. Current limiting

A resistor should be used to limit current spikes that can be caused by voltage fluctuations. Otherwise damage could occur.

## 3. Storage

3.1 Moisture proof bag should only be opened immediately prior to usage.

3.2 Environment should be less than 30°C and 60% RH when moisture proof bag is opened.

3.3 After opening the package MSL Conditions stated on page 1 of this spec should not be exceeded.

3.4 If the moisture sensitivity card indicates higher than acceptable moisture, the component should be baked at min. 60deg +/-5deg for 24 hours.

## 4. Iron Soldering

Hand soldering is not recommended for regular production. These guidelines are for rework only. Soldering iron tip should contact each terminal no more than 3 sec at 350°C, using soldering iron with nominal power less than 25W. Allow min. 2 sec. between soldering intervals.

## 5. Usage

Do not exceed the values given in this specification.

## Application Restrictions

High reliability applications such as military/aerospace, automotive safety/security systems, and medical equipment may require different product. If you have any concerns, please contact Everlight before using this product in your application. This specification guarantees the quality and performance of the product as an individual component. Do not use this product beyond the specification described in this document.

## Revision History:

Rev.	Modified date	File modified contents
1	2016/06/13	New Spec
2	2019/02/20	Divide JL0 into 4 blocks for customer's request
3	2019/04/10	Bin Range of Chromaticity Coordinates JM0 JL0