

Coaxial Frequency Mixer

ZFM-2H+

Level 17 (LO Power +17 dBm) 5 to 1000 MHz



SMA version shown
CASE STYLE: K18

| Connectors | Model |
|-----------------------------|-----------|
| BNC | ZFM-2H+ |
| SMA | ZFM-2H-S+ |
| BRACKET (OPTION "B") | |

+RoHS Compliant

The +Suffix identifies RoHS Compliance. See our web site for RoHS Compliance methodologies and qualifications

Maximum Ratings

| | |
|---|----------------|
| Operating Temperature | -55°C to 100°C |
| Storage Temperature | -55°C to 100°C |
| RF Power | 200mW |
| IF Current | 40mA |
| Permanent damage may occur if any of these limits are exceeded. | |

Coaxial Connections

| | |
|----|---|
| LO | 1 |
| RF | 2 |
| IF | 3 |

Features

- low conversion loss, 6.12 dB typ.
- good L-R isolation, 40 dB typ, L-I, 35 dB typ.
- rugged shielded case

Applications

- VHF/UHF
- cellular
- instrumentation

Outline Drawing

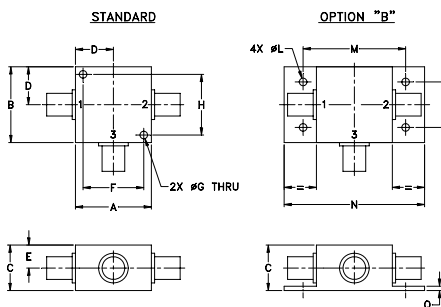

Outline Dimensions (inch/mm)

| A | B | C | D | E | F | G | H | J | K | L | M | N | P | Q | wt |
|-------|-------|-------|-------|------|-------|------|-------|----|----|------|-------|-------|-------|------|-------|
| 1.25 | 1.25 | .75 | .63 | .38 | 1.00 | .125 | 1.000 | -- | -- | .125 | 1.688 | 2.18 | .75 | .07 | grams |
| 31.75 | 31.75 | 19.05 | 16.00 | 9.65 | 25.40 | 3.18 | 25.40 | -- | -- | 3.18 | 42.88 | 55.37 | 19.05 | 1.78 | 70.0 |

Electrical Specifications

| FREQUENCY (MHz) | | CONVERSION LOSS (dB) | | | | LO-RF ISOLATION (dB) | | | | | | LO-IF ISOLATION (dB) | | | | | |
|-----------------|---------|----------------------|----------|------------------|------|----------------------|------|------|------|------|------|----------------------|------|------|------|------|------|
| LO/RF | IF | Mid-Band m | | Total Range Max. | | L | | M | | U | | L | | M | | U | |
| f_L-f_U | | \bar{X} | σ | Max. | Max. | Typ. | Min. | Typ. | Min. | Typ. | Min. | Typ. | Min. | Typ. | Min. | Typ. | Min. |
| 5-1000 | DC-1000 | 6.12 | 0.12 | 7.0 | 10.0 | 50 | 40 | 40 | 30 | 30 | 20 | 45 | 40 | 35 | 25 | 25 | 17 |

1 dB COMP.: +14 dBm typ. L = low range [f_L to $10 f_L$] M = mid range [$10 f_L$ to $f_U/2$] U = upper range [$f_U/2$ to f_U]
m = mid band [$2f_L$ to $f_U/2$]

Typical Performance Data

| Frequency (MHz) | | Conversion Loss (dB) | Isolation L-R (dB) | Isolation L-I (dB) | VSWR RF Port (:1) | VSWR LO Port (:1) |
|-----------------|--------|----------------------|--------------------|--------------------|-------------------|-------------------|
| RF | LO | LO +17dBm | LO +17dBm | LO +17dBm | LO +17dBm | LO +17dBm |
| 5.00 | 35.00 | 5.75 | 73.03 | 64.57 | 1.24 | 1.51 |
| 35.15 | 65.15 | 5.75 | 53.95 | 50.91 | 1.10 | 1.53 |
| 65.30 | 95.30 | 5.78 | 47.75 | 44.94 | 1.10 | 1.52 |
| 125.61 | 95.61 | 5.83 | 45.94 | 42.85 | 1.09 | 1.44 |
| 185.91 | 155.91 | 5.88 | 41.73 | 38.74 | 1.09 | 1.43 |
| 216.06 | 186.06 | 5.87 | 40.07 | 37.26 | 1.10 | 1.39 |
| 276.37 | 246.37 | 5.70 | 37.49 | 34.59 | 1.11 | 1.38 |
| 336.67 | 306.67 | 5.62 | 35.70 | 32.97 | 1.11 | 1.40 |
| 396.98 | 366.98 | 5.78 | 35.50 | 32.29 | 1.12 | 1.37 |
| 457.28 | 427.28 | 6.15 | 33.92 | 30.55 | 1.13 | 1.36 |
| 517.58 | 487.58 | 5.88 | 34.70 | 29.07 | 1.15 | 1.37 |
| 547.74 | 517.74 | 5.91 | 35.38 | 29.45 | 1.15 | 1.39 |
| 608.04 | 578.04 | 6.36 | 34.75 | 28.29 | 1.16 | 1.38 |
| 668.34 | 638.34 | 6.50 | 34.53 | 27.06 | 1.17 | 1.38 |
| 728.65 | 698.65 | 6.30 | 33.69 | 25.41 | 1.20 | 1.36 |
| 788.95 | 758.95 | 6.43 | 32.39 | 25.21 | 1.22 | 1.45 |
| 849.26 | 819.26 | 7.56 | 32.23 | 24.28 | 1.26 | 1.49 |
| 909.56 | 879.56 | 8.59 | 32.46 | 23.91 | 1.34 | 1.52 |
| 969.86 | 939.86 | 8.55 | 32.66 | 24.30 | 1.46 | 1.54 |
| 1000.00 | 970.00 | 8.57 | 32.20 | 24.05 | 1.62 | 1.53 |

Electrical Schematic

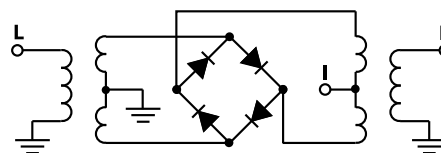

Notes

- Performance and quality attributes and conditions not expressly stated in this specification document are intended to be excluded and do not form a part of this specification document.
- Electrical specifications and performance data contained in this specification document are based on Mini-Circuit's applicable established test performance criteria and measurement instructions.
- The parts covered by this specification document are subject to Mini-Circuit's standard limited warranty and terms and conditions (collectively, "Standard Terms"); Purchasers of this part are entitled to the rights and benefits contained therein. For a full statement of the Standard Terms and the exclusive rights and remedies thereunder, please visit Mini-Circuit's website at www.minicircuits.com/MCLStore/terms.jsp

Mini-Circuits®

www.minicircuits.com P.O. Box 350166, Brooklyn, NY 11235-0003 (718) 934-4500 sales@minicircuits.com

REV. C
M151107
ZFM-2H+
DJ/TD/CP
151008
Page 1 of 2

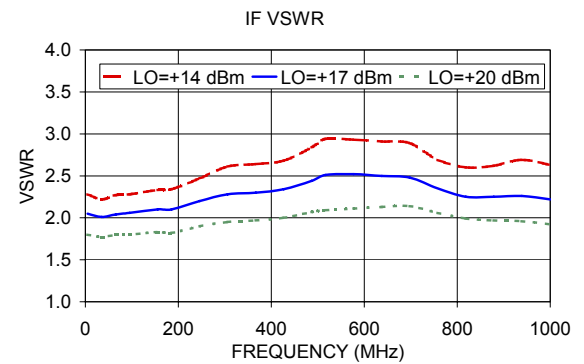
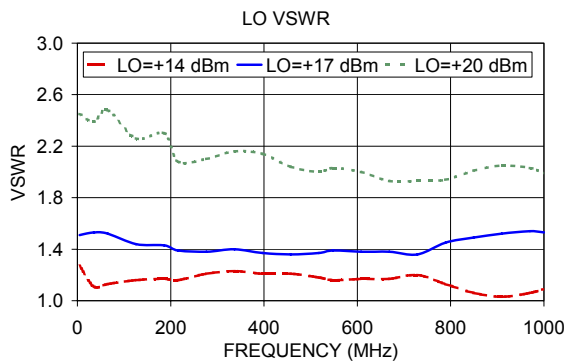
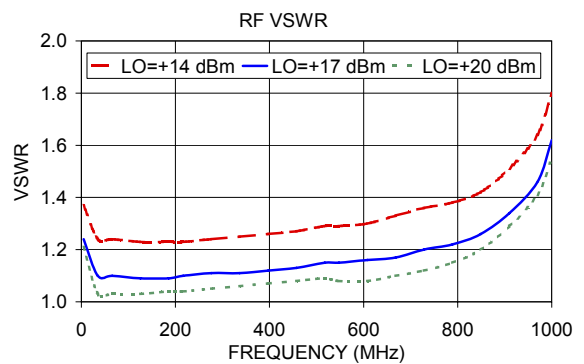
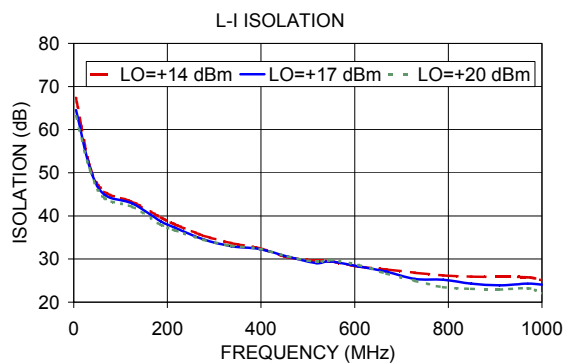
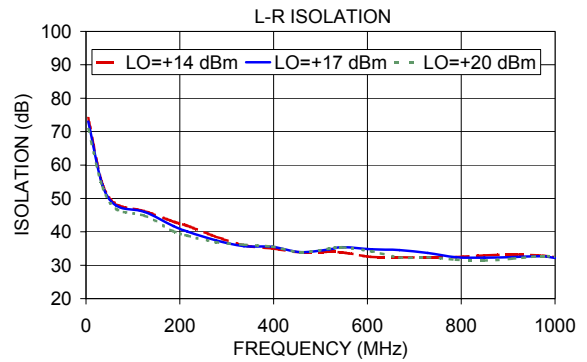
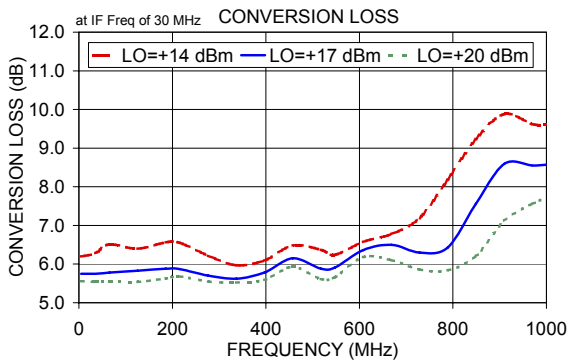

Notes

- A. Performance and quality attributes and conditions not expressly stated in this specification document are intended to be excluded and do not form a part of this specification document.
- B. Electrical specifications and performance data contained in this specification document are based on Mini-Circuit's applicable established test performance criteria and measurement instructions.
- C. The parts covered by this specification document are subject to Mini-Circuits standard limited warranty and terms and conditions (collectively, "Standard Terms"); Purchasers of this part are entitled to the rights and benefits contained therein. For a full statement of the Standard Terms and the exclusive rights and remedies thereunder, please visit Mini-Circuits' website at www.minicircuits.com/MCLStore/terms.jsp

