



VC850M-H-TO46FW-PD

- Infrared VCSEL
- 850 nm, 10 mW
- Multi Mode
- TO-46 Can, with PD
- Flat window cap



Description

VC850M-H-TO46FW-PD is a multi mode infrared VCSEL emitting at typically 850 nm with rated output power of 10 mW cw, mounted into a standard TO-46 package, containing a monitor photo diode and sealed with a flat window cap. The VCSEL works under low forward current and voltage and with 1 Gbps data rate.

Maximum Ratings

Parameter	Symbol	Values		Unit
		Min.	Max.	
Forward Current	I_F		30	mA
Reverse Voltage (@ 10 μ A)	V_F		5	V
Operating Temperature	T_{CASE}	0	+ 70	$^{\circ}$ C
Storage Temperature	T_{STG}	- 40	+ 100	$^{\circ}$ C
Lead Solder Temperature *	T_{SLD}		+ 260	$^{\circ}$ C

* must be completed within 10 seconds

Electro-Optical Characteristics (T_{CASE}=25 $^{\circ}$ C)

Parameter	Symbol	Min.	Values		Unit
			Typ.	Max.	
Emission Wavelength	λ_{Peak}	840	850	860	nm
Spectral Width	$\Delta\lambda$			0.85	nm
Optical Output Power	P_O		8		mW
Threshold Current	I_{TH}		5		mA
Operating Current	I_F		20		mA
Operating Voltage	V_F		2.0	2.3	V
Breakdown Voltage	V_B		-10		V
Slope Efficiency	η	0.2	0.4		mW/mA
Dynamic Resistance	R_D		20	30	Ω
Monitor Current	I_{PD}	0.1		1	mA
Dark Current	I_D			10	nA
PD Reverse Voltage	V_{PDR}	40			V
PD Capacitance	$V_F=0V, Freq=1MHz$			50	pF
	$V_F=5V, Freq=1MHz$			20	



Thermal Characteristics

Parameter	Symbol	Min.	Values Typ.	Max.	Test Conditions	Unit
I_{TH} Temperature Variation	ΔI_{TH}		2.5		$T_C=0$ to 70°C	mA
η Temperature Variation	$\Delta\eta / \Delta T$		-0.5		$T_C=0$ to 70°C , 20mA	%/ $^\circ\text{C}$
λ Temperature Variation	$\Delta\lambda / \Delta T$		0.06		$T_C=0$ to 70°C , 20mA	nm/ $^\circ\text{C}$
I_{PD} Temperature Variation	$\Delta I_{PD} / \Delta T$		0.2		$P_O=8\text{mW}$	%/ $^\circ\text{C}$

Outline Dimensions

TO46FW

TO-46 with flat window

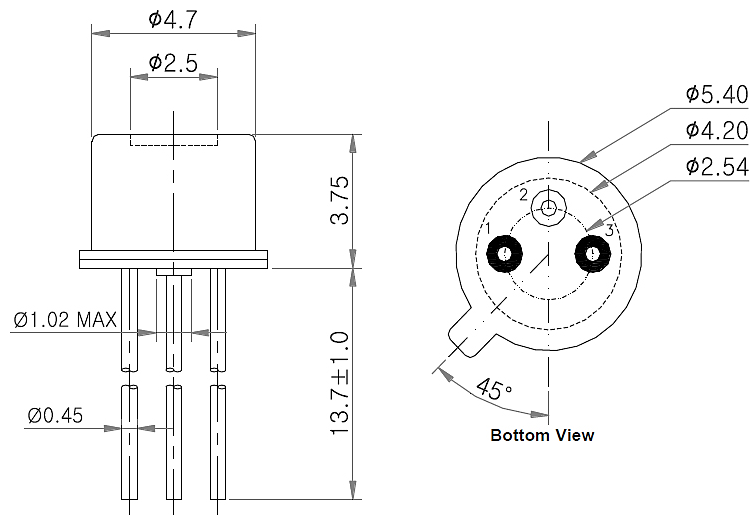

All Dimensions in mm

Electrical Connection

Lead	Description
Pin 1	LD Anode
Pin 2	LD Cathode, PD Anode
Pin 3	PD Cathode

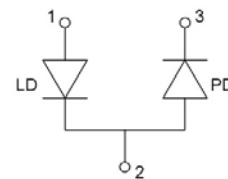



Precautions

Static Electricity:

VCSELs are **sensitive to electrostatic discharge (ESD)**. Precautions against ESD must be taken when handling or operating these VCSELs. Surge voltage or electrostatic discharge can result in complete failure of the device.



Safety Advice:

This VCSEL emits concentrated infrared light which can be **hazardous to the human eye and skin**. This diode is classified as CLASS 3B laser product according to **IEC 60825-1** and **21 CFR Part 1040.10** Safety Standards.

Operation:

Do *only* operate VCSELs with a current source.

Running these LEDs from a voltage source will result in complete failure of the device.

Current of a LED is an exponential function of the voltage across it. Usage of current regulated drive circuits is mandatory.

© All Rights Reserved

The above specifications are for reference purpose only and subjected to change without prior notice