



The Future of Analog IC Technology®

# EV3216DJ-00A

1.3MHz, 36V

## Boost Converter Evaluation Board

### GENERAL DESCRIPTION

The EV3216DJ-00A is the evaluation board for the MP3216. The MP3216 is a current mode step up converter intended for small, low power applications. The MP3216 switches at 1.3MHz and allows the use of tiny, low cost capacitors and inductors to achieve a compact solution.

The MP3216 includes under-voltage lockout, over voltage protection and thermal overload protection preventing damage in the event of an output overload. In addition, MP3216 can disconnect all loads from input DC power supply. The output short circuit protection prevents the Schottky diode and IC from damage. The MP3216 is available in small 6-pin TSOT23 package.

### FEATURES

- Internal 0.6Ω Power MOSFET
- Up to 36V Output Voltage
- 1.3MHz Fixed Switching Frequency
- 42V Over Voltage Shutdown
- Cycle-by-Cycle Over Current Protection
- UVLO, Thermal Shutdown
- Output Disconnection
- Output Short Protection
- Available in TSOT23-6 Packages

### APPLICATIONS

- Portable Applications
- Handheld Computers and PDAs
- Digital Still Cameras

"MPS" and "The Future of Analog IC Technology" are Registered Trademarks of Monolithic Power Systems, Inc.

### ELECTRICAL SPECIFICATION

Parameter	Symbol	Value	Units
Input Voltage	V <sub>IN</sub>	5	V
Output Voltage	V <sub>OUT</sub>	33	V
Output Current	I <sub>OUT</sub>	10	mA

### EV3216DJ-00A EVALUATION BOARD



(L x W x H) 2.0" x 1.8" x 0.2"  
5.0cm x 4.5cm x 0.5cm

Board Number	MPS IC Number
EV3216DJ-00A	MP3216DJ

### Efficiency vs. Output Current

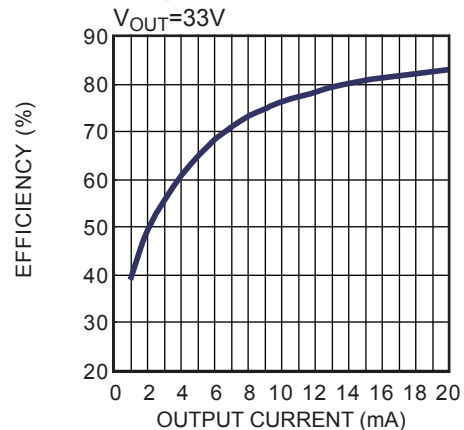

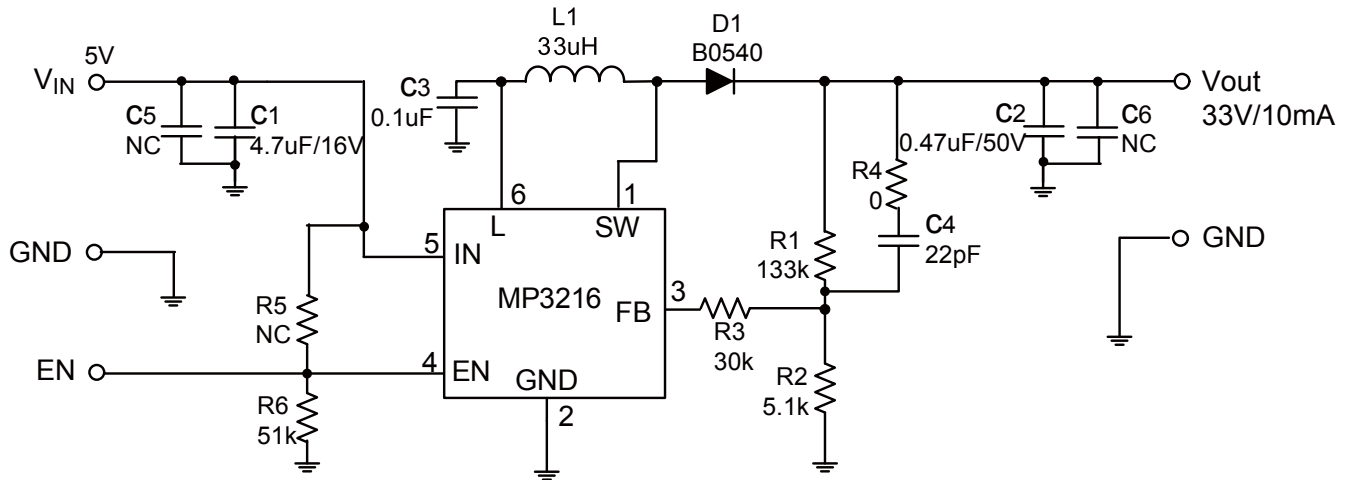
**EVALUATION BOARD SCHEMATIC**

**EV3216DJ-00A BILL OF MATERIALS**

Qty	Ref	Value	Description	Package	Manufacturer	Part Number
1	C1	4.7µF	Ceramic Capacitor, 16V, X5R	0805	muRata	GRM21BR71C475KA73L
1	C2	0.47µF	Ceramic Capacitor, 50V, X7R	0805	muRata	GRM21BR71H474KA88
1	C3	0.1µF	Ceramic Capacitor, 16V, X7R	0603	muRata	GRM188R71C104KA01D
1	C4	22pF	Ceramic Capacitor, 50V, COG	0603	muRata	GRM1885C1H220JA01D
2	C5, C6	NC				
1	D1	B0540	Diode Schottky, 40V, 0.5A	SOD-123	Diodes Inc	B0540W
1	L1	33µH	Inductor, 0.63 A	D63LCB	TOKO	D53LCB-#A921CY-330M
1	R1	133kΩ	Resistor, 1%	0603	Yageo	RC0603FR-07133KL
1	R2	5.1kΩ	Resistor, 1%	0603	Yageo	RC0603FR-075K1L
1	R3	30kΩ	Resistor, 1%	0603	Yageo	RC0603FR-0730KL
1	R4	0Ω	Resistor	0603	Any	
1	R5	NC				
1	R6	51kΩ	Resistor	0603	Any	
1	U1	MP3216	Boost Converter	TSOT23-6	MPS	MP3216DJ-LF-Z R2

## PRINTED CIRCUIT BOARD LAYOUT

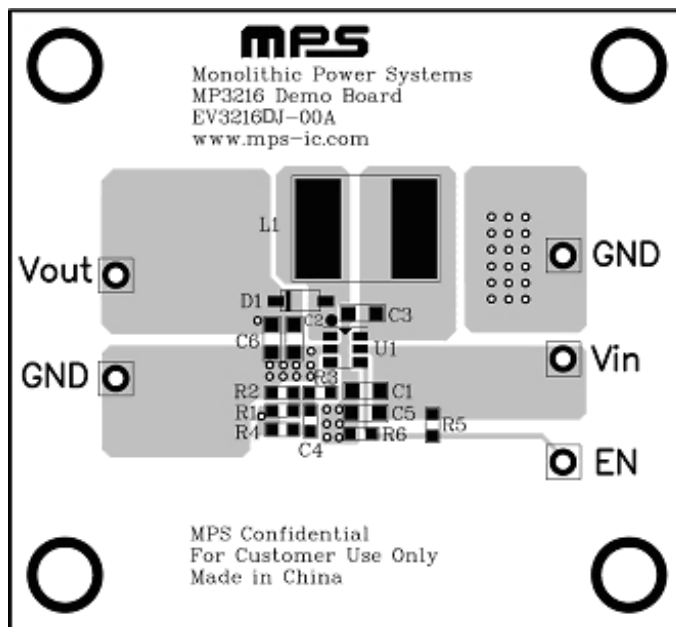

Figure 1—Top Layer

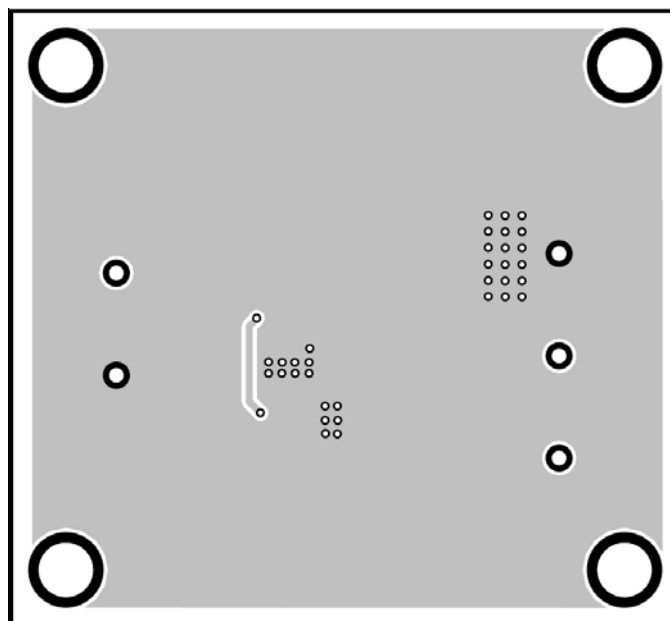

Figure 2—Bottom Layer

## QUICK START GUIDE

The output voltage of this board is set to 33V. The board layout accommodates most commonly used inductors and output capacitors.

1. Preset Power Supply to  $V_{IN} = 5V$ .
2. Turn Power Supply off.
3. Connect Power Supply terminals to:  
Positive (+):  $V_{in}$   
Negative (-): GND
4. Connect Load to:  
Positive (+):  $V_{out}$   
Negative (-): GND
5. Turn Power Supply on after making connections.
6. The MP3216 is enabled once  $V_{EN} > 2V$ . To disable the MP3216, short EN to GND.
7. The output voltage  $V_{OUT}$  can be changed by varying R1. Calculate the new value using the formula:

$$R1 = \frac{R2(V_{OUT} - V_{FB})}{V_{FB}}$$

Where  $V_{FB} = 1.24V$  and  $R2 = 5.1k\Omega$

For example, for  $V_{OUT} = 33V$

$$R1 = \left( \frac{33 - 1.24}{1.24} \right) \times 5.1k\Omega = 130.6k\Omega$$

There choose a 133 k $\Omega$  standard 1% value.

**NOTICE:** The information in this document is subject to change without notice. Please contact MPS for current specifications. Users should warrant and guarantee that third party Intellectual Property rights are not infringed upon when integrating MPS products into any application. MPS will not assume any legal responsibility for any said applications.