

## Digital Panel Meters 47 Series

### PULSE INPUT TOTALIZER

(6-digit, LED display type)

#### Functions & Features

- 6-digit digital panel meter
- 1/8 DIN size
- Process integration/totalization with scaling factor adjustment
- Count stored at the loss of power supply
- Alarm tone optional
- IP66 front panel
- Separable terminal block
- Rear terminal cover for safety strapped to the meter

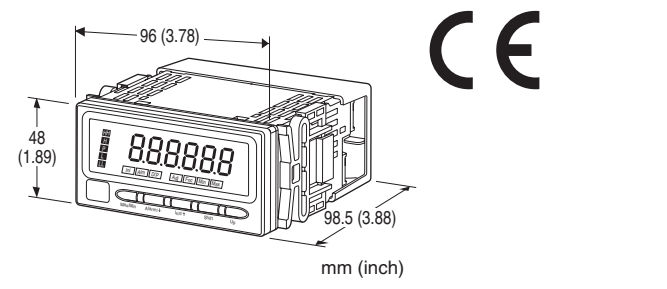

### MODEL: 47LPQ-[1][2][3][4]-[5][6]

#### ORDERING INFORMATION

- Code number: 47LPQ-[1][2][3][4]-[5][6]
- Specify a code from below for each of [1] through [6].  
(e.g. 47LPQ-1A1G-M2/B/Q)
- Specify the specification for option code /Q  
(e.g. /C01/S01/SET)

#### [1] INPUT

- 1: Open collector or voltage pulse
- 2: Mechanical contact

#### [2] DC OUTPUT

0: Without

##### Current

- A: 4 - 20 mA DC (Load resistance 550 Ω max.)  
D: 0 - 20 mA DC (Load resistance 550 Ω max.)

##### Voltage

- 4: 0 - 10 V DC (Load resistance 10 kΩ min.)  
5: 0 - 5 V DC (Load resistance 5000 Ω min.)  
6: 1 - 5 V DC (Load resistance 5000 Ω min.)  
4W: -10 - +10 V DC (Load resistance 10 kΩ min.)

#### [3] ALARM OUTPUT

- 0: None  
1: N.O. relay contact, 4 points  
2: SPDT relay contact, 2 points

#### [4] DISPLAY COLOR

- R: Red  
YR: Orange  
G: Green  
BG: Bluegreen  
B: Blue  
W: White

#### [5] POWER INPUT

##### AC Power

M2: 100 - 240 V AC (Operational voltage range 85 - 264 V, 50/60 Hz)

##### DC Power

- R: 24 V DC  
(Operational voltage range 24 V ±10 %, ripple 10 %p-p max.)  
P: 110 V DC  
(Operational voltage range 85 - 150 V, ripple 10 %p-p max.)

#### [6] OPTIONS (multiple selections)

##### Alarm Tone

- blank: Without  
/B: With (selectable only with alarm output)

##### Other Options

- blank: none  
/Q: Option other than the above (specify the specification)

#### SPECIFICATIONS OF OPTION: Q (multiple selections)

##### COATING (For the detail, refer to M-System's web site.)

Moving parts and indicators are not coated.

- /C01: Silicone coating  
/C02: Polyurethane coating  
/C03: Rubber coating

##### TERMINAL SCREW MATERIAL

/S01: Stainless steel

##### EX-FACTORY SETTING

/SET: Preset according to the Ordering Information Sheet  
(No. ESU-9516)

#### GENERAL SPECIFICATIONS

**Construction:** Panel flush mounting

**Degree of protection:** IP66; applicable to the front of the panel meter mounted according to the specified panel cutout

**Connection:** M3 separable screw terminal (torque 0.6 N·m)

**Screw terminal:** Nickel-plated steel (standard) or stainless steel

**Housing material:** Flame-resistant resin (gray)

**Isolation:** Input to DC output to HH output or H output to L output or LL output to power

**Setting:** (Front button)

- Scaled range
- Input type
- Alarm setpoint
- Hysteresis (deadband)
- Others

(Refer to the instruction manual for details)

**Lockout setting:** Prohibiting certain operations; protecting settings

## DISPLAY

**Display:** 16 mm (.63) high, 6 digits, 7-segment LED

**Display range:** -99999 to 999999

**Decimal point position:**  $10^{-1}$ ,  $10^{-2}$ ,  $10^{-3}$ ,  $10^{-4}$ ,  $10^{-5}$  or none

**Zero indication:** Higher-digit zeros are suppressed.

### Overflow count modes

**Reset:** Reset and restart at 0 or 1

(Scaling values at factory setting)

**Hold:** Hold at 100 %; display blinking

**Input indication:** 'D/P' turns on for 1 second after a valid pulse train has been detected (applied to 1/100 scaled signal if the input type is selected).

'Adj' turns on with control input.

### Alarm status indication

**LL indicator:** Green LED turns on when the LL alarm is tripped.

**L indicator:** Green LED turns on when the L alarm is tripped.

**H indicator:** Red LED turns on when the H alarm is tripped.

**HH indicator:** Red LED turns on when the HH alarm is tripped.

**P indicator:** Amber LED turns on when none of the other alarms is tripped.

Only 'P' turns on with no-alarm-output type. 'LL' or 'HH' does not turn on with dual-alarm-output type.

All setpoints can be independently set either for Hi or Lo alarm trip.

### Function indicators:

Ini, Alm, D/P, Adj, Fnc, Min, Max

Display mode status and operation status, amber ON or blink

**Engineering unit indication:** Sticker label attached

DC, AC, mV, V, kV,  $\mu$ A, mA, A, kA, mW, W,

kW, var, kvar, Mvar, VA, Hz,  $\Omega$ , k $\Omega$ , M $\Omega$ ,

cm, mm, m, m/sec, mm/min, cm/min, m/min,

m/h, m/s<sup>2</sup>, inch, l, l/s, l/min, l/h, m<sup>3</sup>, m<sup>3</sup>/sec,

m<sup>3</sup>/min, m<sup>3</sup>/h, Nm<sup>3</sup>/h, N·m, N/m<sup>2</sup>, g, kg, kg/h,

N, kN, Pa, kPa, MPa, t, t/h, °C, °F, %RH, J,

kJ, MJ, rpm, sec, min, min<sup>-1</sup>, pH, %, ppm, kWh, MWh, Wh

## INPUT SPECIFICATIONS

**Default measuring range:** 0 – 999999

**Sensor excitation:** 12 V DC  $\pm$ 10 %, 30 mA

Current limit protection at approx. 60 mA

### Open Collector & Voltage Pulse

**Minimum pulse width:**  $\geq$  5  $\mu$ sec.

**Maximum frequency:** 100 Hz

10kHz for Input type setting of 1/100 counting scale

### Mechanical Contact

**Minimum pulse width:**  $\geq$  500 msec.

**Maximum frequency:** 1 Hz

### ■ Open Collector & Mechanical Contact

**Detecting voltage/current:** Approx. 8 V DC @ 1.6 mA

**Detecting levels:**  $\leq$  300  $\Omega$  / 0.6 V for ON;

$\geq$  10 k $\Omega$  / 4.5 V for OFF

### ■ Voltage Pulse

**Voltage range:** 0 – 5 through 26.4 V

$\pm$ 5 –  $\pm$ 26.4 V (equal amplitude at both poles)

**Waveform:** Square

**Input impedance:** 10 k $\Omega$  min.

**Low level:** -26.4 – 0.6 V DC

**High level:** 4.5 – 26.4 V DC

**■ Control Input:** Reset count, Hold count or Invert count (selectable function)

**Detecting time:**  $\geq$  200 msec.

**Detecting levels:** 4.5 – 26.4 V or short circuit across the terminals 1 and 5 for ON; -26.4 – 0.6 V for OFF

## OUTPUT SPECIFICATIONS

### ■ DC Output

- DC Current

**Operational range:** -5 – +105 %

- DC Voltage

**Operational range:** -5 – +105 %

### ■ Alarm Output: Relay contact

**Rated load:** 250 V AC @ 3 A ( $\cos \theta = 1$ )

30 V DC @ 3 A (resistive load)

**Maximum switching voltage:** 250 V AC, 30 V DC

**Maximum switching power:** 750 VA, 90 W (resistive load)

**Minimum load:** 5 V DC @ 10 mA

**Mechanical life:**  $\geq$  5  $\times$  10<sup>6</sup> cycles (rate 180 cycles/min.)

## INSTALLATION

### Power consumption

•AC: Approx. 6.5VA

•DC: Approx. 3 W

**Operating temperature:** -10 to +55°C (14 to 131°F)

**Operating humidity:** 30 to 90 %RH (non-condensing)

**Mounting:** Panel flush mounting

**Weight:** 300 g (0.66 lb)

## PERFORMANCE

**DC output accuracy:**  $\pm 0.1\%$

**Temp. coefficient:**  $\pm 0.015\%/^{\circ}\text{C}$  ( $\pm 0.008\%/^{\circ}\text{F}$ )

**Output resolution:** Max. 14 bits

**Response time:**  $\leq 0.5$  sec.

(alarm output: 0 - 100 % at 90 % setpoint)

$\leq 0.5$  sec. (DC output: 0 - 90 %)

**Line voltage effect:**  $\pm 0.1\%$  over voltage range

**Insulation resistance:**  $\geq 100\ \text{M}\Omega$  with 500 V DC

**Dielectric strength:** 2000 V AC @ 1 minute (input to DC output to HH output or H output to L output or LL output to power to ground)

## STANDARDS & APPROVALS

### EU conformity:

EMC Directive

EMI EN 61000-6-4

EMS EN 61000-6-2

Low Voltage Directive

EN 61010-1

Measurement Category II (alarm output)

Installation Category II (power)

Pollution degree 2

Input or DC output to alarm output to power: Reinforced insulation (300 V)

Input to DC output: Basic insulation (300 V)

RoHS Directive

### Protection against access to the terminal blocks:

Finger protection (VDE 0660-514)

## EXTERNAL VIEW

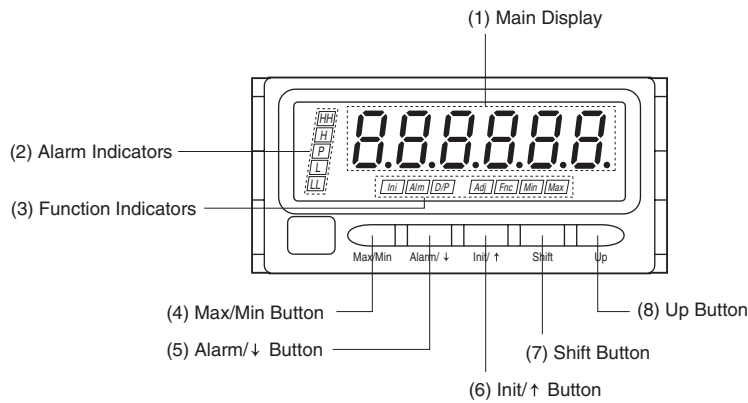

### • COMPONENT IDENTIFICATION

No.	COMPONENT	FUNCTION
(1)	Main display	Indicates present values, setting values and status of the unit.
(2)	Alarm indicators	Indicate alarm status of the input signal.
(3)	Function indicators	Indicate the status in each setting mode.
(4)	Max/Min button	Used to switch the main display to show the present values, maximum values or minimum values etc.
(5)	Alarm/↓ button	Used to confirm alarm setting value and to move on to the alarm and other setting modes; or to shift through setting items in each setting mode.
(6)	Init/↑ button	Used to move on to the scaling and other setting modes; or to shift through setting items in each setting mode.
(7)	Shift button	Used to move on to the setting standby status of each setting mode and shift through display digits in each setting mode.
(8)	Up button	Used to reset the counter and select setting values in each setting mode.

Note: Refer to the operating manual for details on each function.

**EXTERNAL DIMENSIONS & TERMINAL ASSIGNMENTS unit: mm (inch)**

■ TOP VIEW

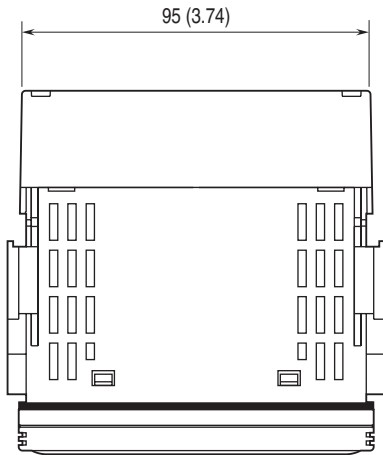

■ FRONT VIEW

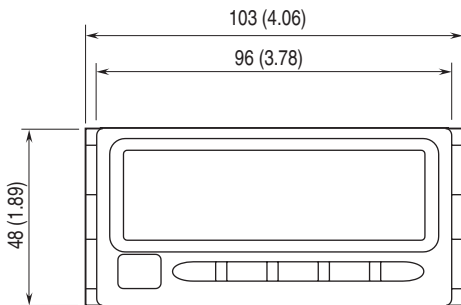

■ SIDE VIEW

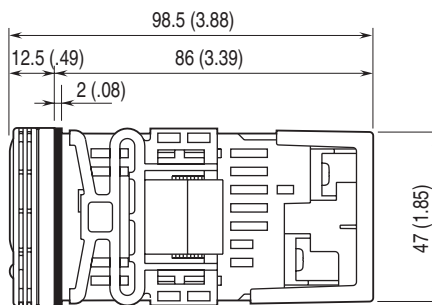

■ REAR VIEW

• No Alarm Output

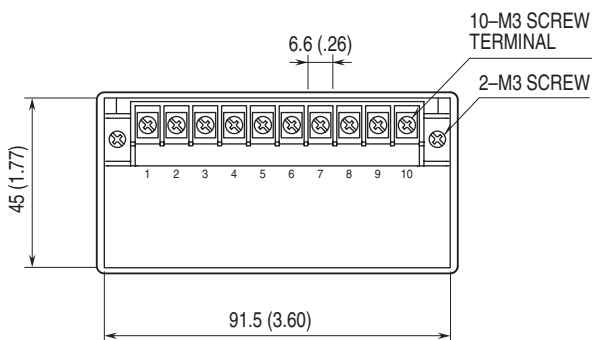

• Alarm Output

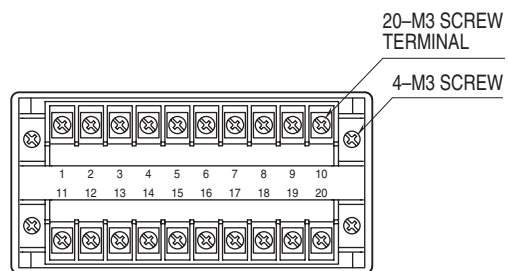

**MOUNTING REQUIREMENTS unit: mm**

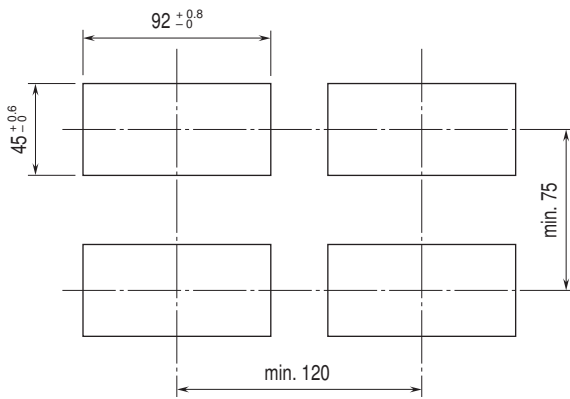

Panel thickness: 1.6 to 8.0 mm

## SCHEMATIC CIRCUITRY & CONNECTION DIAGRAM

### ■ ALARM OUTPUT CODE 0: No alarm output

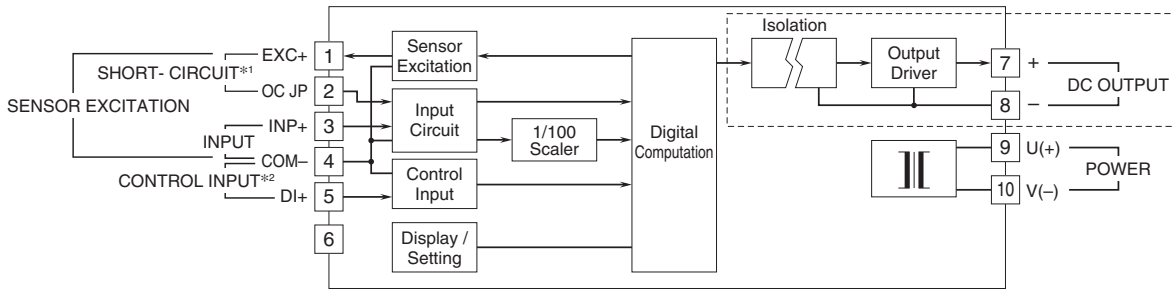

### ■ ALARM OUTPUT CODE 1: N.O. contact, 4 points

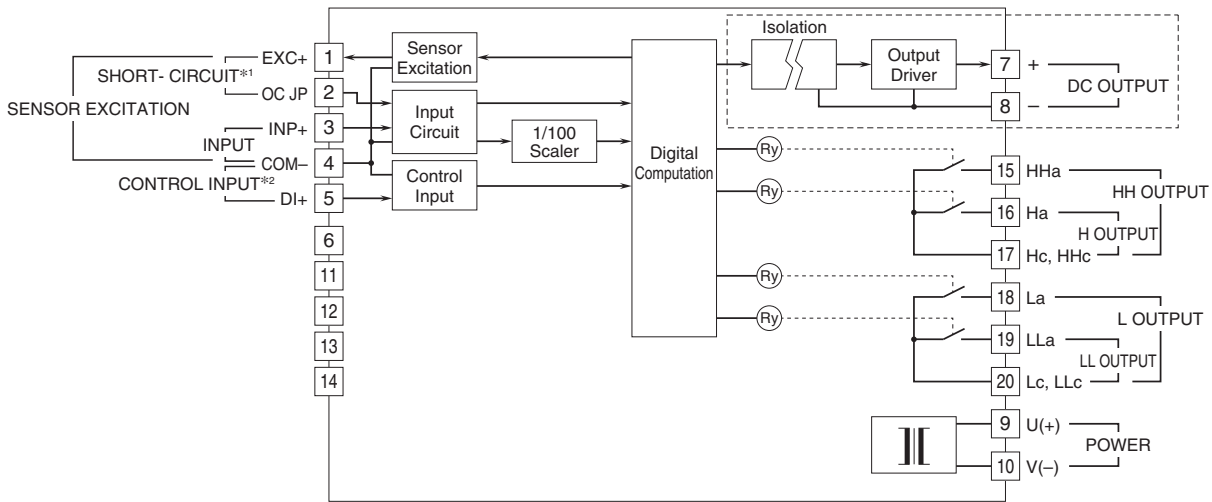

### ■ ALARM OUTPUT CODE 2: SPDT contact, 2 points

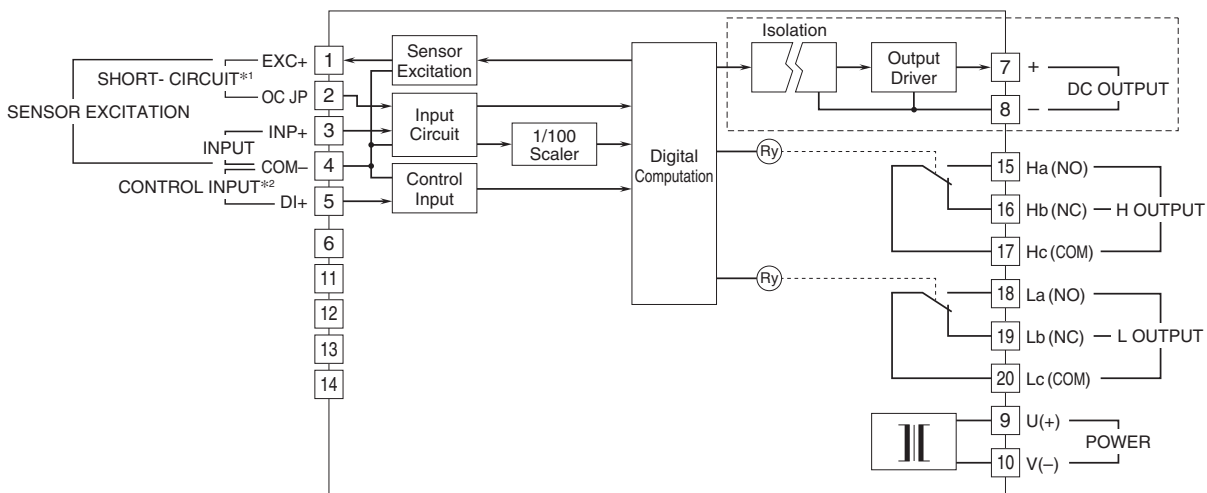

\*1. Close across the terminals for open collector or mechanical contact. Refer to the figure below.  
 \*2. For detailed connection of CONTROL INPUT, refer to the operating manual (EM-9516-B).

#### ■ Input Connection Example • Open Collector or Mechanical Contact

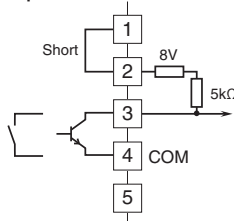

#### ■ Relay Protection • AC Powered

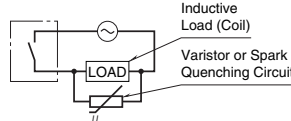

#### • DC Powered

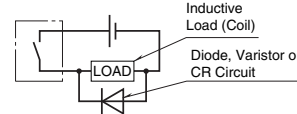

Note 1: The section enclosed by broken line is only with DC output option.

Note 2: Chattering input signals cannot be measured accurately.

Add a capacitor (10000 pF) or similar devices to the input terminals to eliminate the input signals' instability.



Specifications are subject to change without notice.