



Infrared
Product Data Sheet
LTE-3273DL

Spec No. :DS50-2014-0066
Effective Date: 07/22/2017
Revision: A

LITE-ON DCC

RELEASE

BNS-OD-FC001/A4

IR Emitter and Detector LTE-3273DL

1. Description

Lite-On offers a broad range of discrete infrared components for application such as remote controller, IR wireless data transmission, security alarm & etc. The product line includes GaAs 940nm IREDs, AlGaAs high power 880nm IREDs, AlGaAs high speed 875nm/850nm IREDs, PIN Photodiodes, Phototransistor and Photodarlington.

1.1. Features

- Special for high current and low forward voltage
- Available for pulse operating
- Wide viewing angle
- Blue transparent color package

1.2. Applications

- Sensor
- Remote controller
- 940nm emitter

2. Outline Dimensions

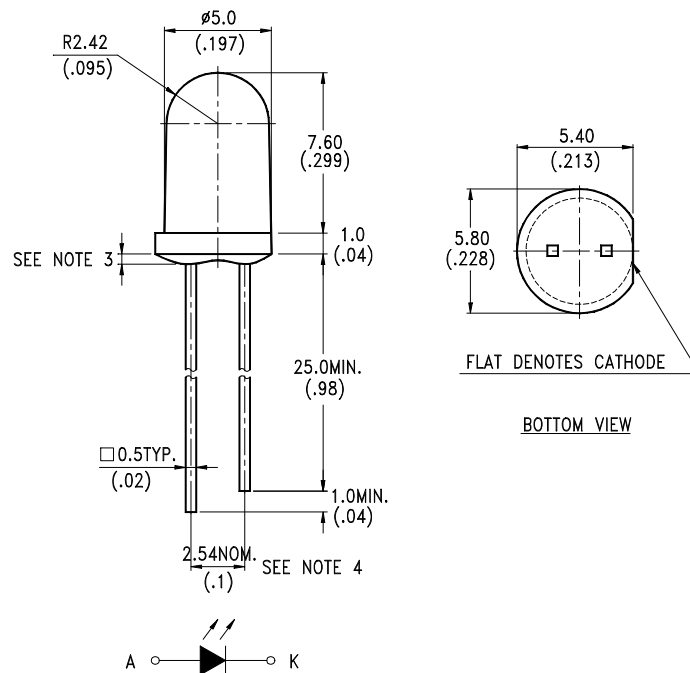

Notes :

1. All dimensions are in millimeters (inches).
2. Tolerance is ± 0.25 mm (.010") unless otherwise noted.
3. Protruded resin under flange is 0.5mm (.02") max.
4. Lead spacing is measured where the leads emerge from the package.
5. Specifications are subject to change without notice.
6. Manufacturing site: Thailand & ChangZhou

IR Emitter and Detector LTE-3273DL

3. Absolute Maximum Ratings at TA=25°C

Parameter	Maximum Rating	Unit
Power Dissipation	150	mW
Peak Forward Current (300pps, 10µs pulse)	2	A
Continuous Forward Current	100	mA
Reverse Voltage	5	V
Operating Temperature Range	-40°C to + 85°C	
Storage Temperature Range	-55°C to + 100°C	
Lead Soldering Temperature [1.6mm (.063") From Body]	260°C for 5 Seconds	

4. Electrical / Optical Characteristics at TA=25°C

Parameter	Symbol	Min.	Typ.	Max.	Unit	Test Condition
Radiant Intensity	I_E	5.6	8.0		mW/sr	$I_F = 20\text{mA}$
		28.0	40.0			$I_F = 100\text{mA}$
Peak Emission Wavelength	λ_{Peak}		940		nm	$I_F = 20\text{mA}$
Spectral Line Half-Width	$\Delta\lambda$		50		nm	$I_F = 20\text{mA}$
Forward Voltage	V_F		1.25	1.6	V	$I_F = 50\text{mA}$
			1.85	2.3		$I_F = 500\text{mA}$
Reverse Current	I_R			100	µA	$V_R = 5\text{V}$
Value Angle	$2\theta_{1/2}$		45		deg.	

IR Emitter and Detector LTE-3273DL

5. Typical Electrical / Optical Characteristics Curves

(25°C Ambient Temperature Unless Otherwise Noted)

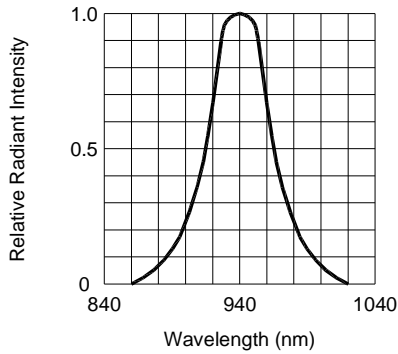

FIG.1 SPECTRAL DISTRIBUTION

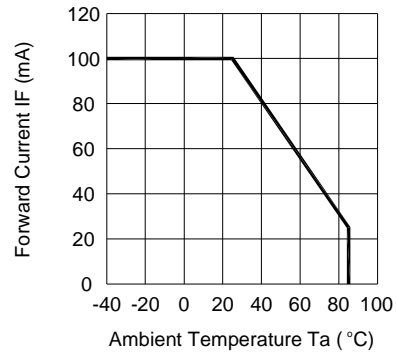

FIG.2 FORWARD CURRENT VS. AMBIENT TEMPERATURE

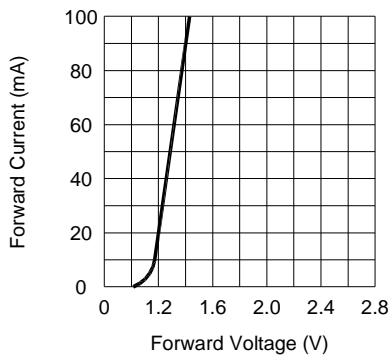

FIG.3 FORWARD CURRENT VS. FORWARD VOLTAGE

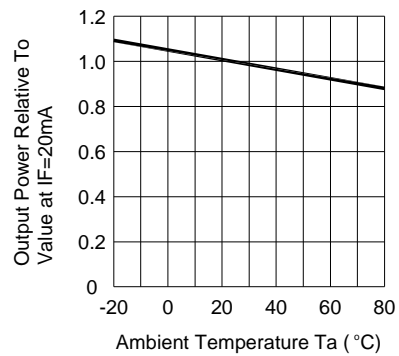

FIG.4 RELATIVE RADIANT INTENSITY VS. AMBIENT TEMPERATURE

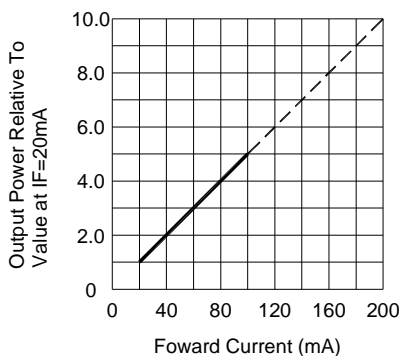

FIG.5 RELATIVE RADIANT INTENSITY VS. FORWARD CURRENT

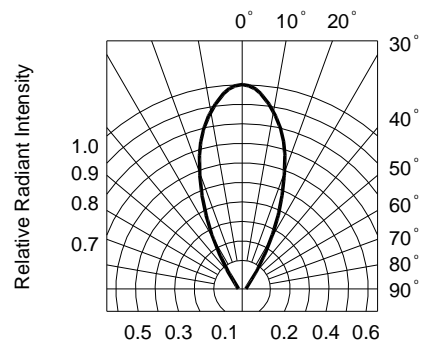

FIG.6 RADIATION DIAGRAM