

# 257-007 Connector Receptacle Assembly Stainless Steel Harsh Environment

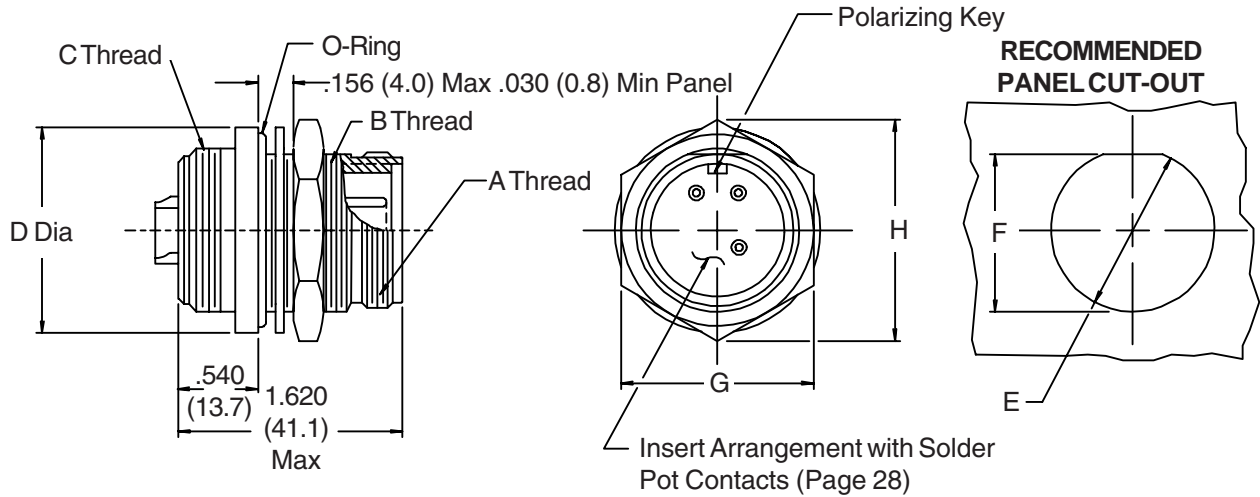
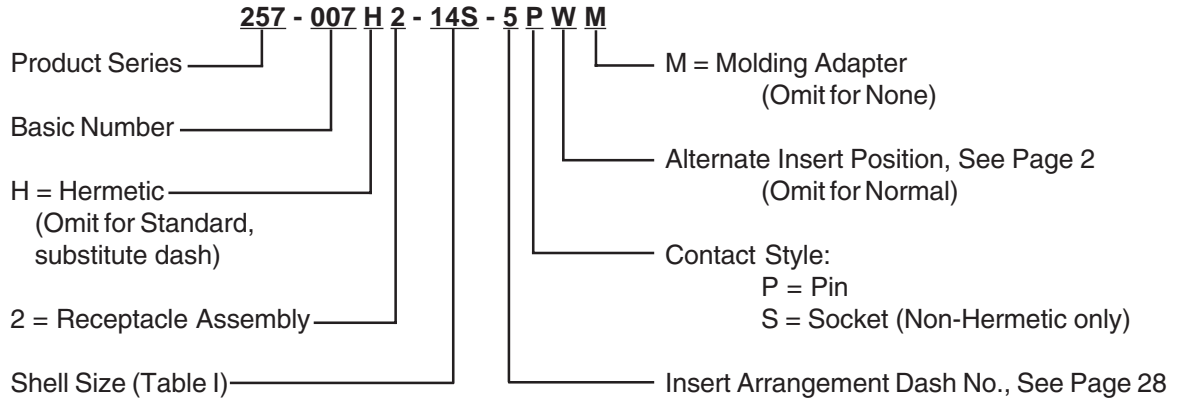

**TABLE I**

Shell Size	A Thread Class 2A	B Thread Class 2A	C Thread Class 2A	D Dia Max	E Dia + .010 (0.3) - .000 (0)	F + .010 (0.3) - .000 (0)	G Flats	H Max
10SL	.625 - .1P-1L	3/4 - 20 UNEF	5/8 - 24 UNEF	1.100 (27.9)	.760 (19.3)	.710 (18.0)	.938 (23.8)	1.090 (27.7)
12	.750 - .1P-1L	7/8 - 20 UNEF	3/4 - 20 UNEF	1.250 (31.8)	.885 (22.5)	.835 (21.2)	1.062 (27.0)	1.230 (31.2)
14S	.875 - .1P-1L	1 - 20 UNEF	7/8 - 20 UNEF	1.450 (36.8)	1.010 (25.7)	.965 (24.5)	1.250 (31.8)	1.440 (36.6)
18	1.125 - .1P-1L	1 1/4 - 18 UNEF	1 1/8 - 16 UN	1.750 (44.5)	1.260 (32.0)	1.210 (30.7)	1.500 (38.1)	1.730 (43.9)
20	1.250 - .1P-1L	1 1/2 - 18 UNEF	1 1/4 - 16 UN	2.030 (51.6)	1.510 (38.4)	1.460 (37.1)	1.750 (44.5)	2.020 (51.3)
24	1.500 - .1P-1L	1 3/4 - 18 UNEF	1 1/2 - 16 UN	2.340 (59.4)	1.760 (44.7)	1.710 (43.4)	2.000 (50.8)	2.320 (58.9)
28	1.750 - .1P-1L	2 - 18 UNEF	1 3/4 - 16 UN	2.550 (64.8)	2.010 (51.1)	1.960 (49.8)	2.187 (55.5)	2.530 (64.3)

1. Metric dimensions (mm) are indicated in parentheses.
2. Electrical safety limits must be established by the user. Peak voltages, switching surges, etc., should be used to determine the safety of the application.