

**Panel Mounted Multi Power Meter 51-UNIT**

**MULTI POWER METER**

**MODEL 51U**

**MODEL & SUFFIX CODE SELECTION**

51U-□□□□□

**MODEL** \_\_\_\_\_

**INPUT (balanced load) \*1** \_\_\_\_\_

- 0 : Single-phase / 2-wire, 105V / 5A AC (P. 5/16) \*2
- 1 : Single-phase / 3-wire, 105V / 210V / 5A AC (P. 7/16)
- 2 : 3-phase / 3-wire, 220V / 5A AC (P. 10/16)
- 3 : 3-phase / 3-wire, 110V / 5A AC (P. 10/16)
- 4 : 3-phase / 4-wire, 110V /  $\sqrt{3}$  V / 5A AC (P. 13/16)

**DISPLAY ITEMS \*3** \_\_\_\_\_

- A : A × 3
- B : V × 3
- C : A × 3, V × 3
- D : A × 3, V × 3, kW
- E : A × 3, V × 3, kWh
- F : A × 3, kW, kWh
- G : Hz, PF, kvar
- H : V × 3, MV<sub>0</sub>, V<sub>0</sub>
- J : A × 3, DA, MDA
- K : A × 3 or DA, MDA, alarm setpoint
- L : Hz, PF, kW
- M : PF, kW, kWh
- N : V × 3, kW, kWh
- P : A × 3 or DA or MDA, V × 3, kWh
- Q : A × 3, PF, kW
- R : A × 3, PF, kvar
- S : A × 3 or PF, kW, kWh
- T : A × 3, PF, kvarh
- U : V × 3, Hz
- W : A × 3 or DA or MDA, V × 3, alarm setpoint
- X : A × 3, kvar, kvarh
- Y : Hz, PF, kWh

**OUTPUT** \_\_\_\_\_

- 0 : None
- 1 : 4 – 20mA DC, 3 points
- 2 : 4 – 20mA DC, 2 points + pulse
- 3 : 4 – 20mA DC, 2 points + reset input
- 4 : RS-485 (MsysNet use only. Consult Factory.)

**AUXILIARY POWER SUPPLY** \_\_\_\_\_

- M : 85 – 264V AC
- R : 24V DC
- P : 110V DC

**REMOTE CONTROL** \_\_\_\_\_

- 1 : 85 – 132V AC or 85 – 143V DC
- 2 : 20 – 30V DC
- 3 : 170 – 264V AC

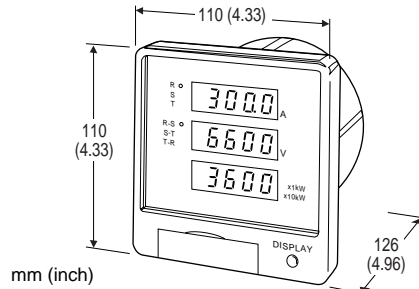

**Functions & Features**

- Measuring all major factors required for power & energy management
- Transducer combined with 3 displays in one enclosure
- RS-485 or DC current output
- Totalized counter values stored in non-volatile memory
- Occupying less panel space, requiring fewer connection
- Easily replacing standard 110 mm (4 5/16 in.) square size, long scale meter
- Parameters are field-selectable

**Application Examples**

- Updating conventional power meter to a remote controlled power logger, only with additional transmitter output wiring
- Installed within an industrial piece of electrical equipment

\*1 : Some display items or output types are not selectable according to the input type. See the detailed selection guide in the following pages.

\*2 : Page No. of the detailed selection guide

\*3 : V = Line voltage                      A = Line current  
 kW = Kilowatt                          kvar = Kilovar  
 PF = Power factor                      Hz = Frequency  
 kWh = Kilowatthours                  kvarh = Kilovarhours  
 DA = Demand (current)  
 MDA = Maximum demand (current)  
 V<sub>0</sub> = Zero-phase voltage  
 MV<sub>0</sub> = Maximum zero-phase voltage

**DEFAULT SETTING**

| ITEM                      | DEFAULT SETTING                                |
|---------------------------|--|
| CT primary rating         | 5.00A (element S for demand, time lag 15 min.) |
| VT primay rating          | 110.0V or 220.0V, same as input rating         |
| GVT tertiary rating       | 110.0V   |
| Frequency range           | 45 – 65 Hz                                     |
| Pulse out. scaling factor | 1 kWh/pulse (kvarh/pulse)                      |
| Demand alarm setpoint     | 100%   |
| RS-485                    | Address: 01<br>Transmission speed: 4800 bps    |

## GENERAL SPECIFICATIONS

**Construction:** 110 mm-square (4 <sup>5</sup>/<sub>16</sub> in.) panel surface, cylindric body

### Connection

**Input & auxiliary power:** M4 screw terminals

**Output:** M3 screw terminals

**Housing material:** plastic (black)

**Isolation:** input to output to power; not isolated between analog outputs

**Scaling:** primary values for CT and VT; tertiary value for GVT (Inform M-System CT and VT ratios when ordering.)

**CT:** 5 – 8000A (up to 15000A for Code K)

**VT:** 110 – 77kV

**GVT:** 63.5 – 190.5V

**Time lag for demand:** 0 sec., 30 sec. or 1, 2, 3, 5, 7, 10, 15, 30 min. (default: 15 min.)

**Sampling cycle:** 400  $\mu$ sec. (DO NOT connect a device such like inverters.)

**Measurable frequency ranges:** 45 – 44 Hz, 55 – 65 Hz, 45 – 65 Hz

**Low-end cutout:** Display shows 0 for the input less than the following: approx. 1% for current, watt and var; approx. 3% for voltage.

## INPUT

### ■VOLTAGE INPUT

(must be balanced with 3-phase connection)

#### Operational range

**Voltage, watt, var, zero-phase voltage:** 0 – 100% of rating

**Power factor:**  $\geq 30V$

**Frequency:**  $\geq 30V$

**Overload capacity:** 200% of rating for 60 sec., 115% for 3 hours

**Input burden:** 0.3VA/phase

### ■CURRENT INPUT

(may be unbalanced with 3-phase connection)

#### Operational range

**Current, watt, var, demand:** 0 – 100% of rating

**Power factor:**  $\geq 5\%$  of rating

**Overload capacity:** 4000% of rating for 1 sec., 2000% for 60 sec., 115% for 3 hours

**Input burden:** 0.1VA/phase

### ■REMOTE CONTROL

**Display switching:** same functions as the front DISPLAY button does; input time  $\geq 0.3$  sec., input current 5mA

**Reset input:** max. zero-phase voltage and demand; input time  $\geq 0.3$  sec., input current 5mA

## OUTPUT

**■CURRENT OUTPUT:** 4 – 20mA DC

**Load resistance:** 500 $\Omega$  maximum

**■PULSE OUTPUT:** totalizing watt in forward flow or var in lag.

**Scaling factor:** 0.01, 0.1, 1, 10, 100 kWh/pulse (default: 1)

**Contact rating:** 110V DC @0.1A (resistive load)  
110V AC @0.1A (resistive load)

**Pulse width time:** 100 – 150 msec.  
(pulse rate  $\leq 12000$  pulses/h)

### ■TRANSMISSION OUTPUT (Multi-Meter Protocol)

**Transmission:** conform to RS-485, EIA

**Transmission distance:** 1 kilometer max. ( $\leq 31$  units)

**Cable:** shielded twisted-pair cable (CPEV-S 0.9 dia.)

**Terminator:** incorporated

### ■DEMAND ALARM CONTACT OUTPUT

**Alarm setpoint:** 5 – 100%; adjustable in 0.5% increments

**Contact rating:** 110V DC @0.1A (resistive load)

**ON resistance:**  $\leq 50\Omega$

## I/O RANGES

Proportional to 4 – 20mA DC

| DISPLAY ITEMS           |               | RATING   | INPUT RANGE   |
|-------------------------|---------------|--|---|
| Current                 |               | 5A   | 0 – 5A  |
| Voltage                 | 1 $\phi$ / 2w | 1 – 2  | 105V  |
|                         | 1 $\phi$ / 3w | 1 – N  | 105V  |
|                         |               | 2 – N  | 105V  |
|                         | 3 $\phi$ / 3w | 1 – 2  | 210V  |
| line                    |               | 110V<br>220V                                     |   |
| 3 $\phi$ / 4w           | line<br>phase | 110V   | 0 – 150V  |
|                         |               | 110 / $\sqrt{3}$ V                               | 0 – 150 / $\sqrt{3}$ V  |
| Watt                    |               | 110V / 5A<br>110V / 5A<br>220V / 5A<br>220V / 5A | 0 – 1 kW (0 – 5 kW)<br>-1 – +1 kW (-0.5 – +0.5 kW)<br>0 – 2 kW<br>-2 – +2 kW  |
| Var                     |               | 110V / 5A<br>110V / 5A<br>220V / 5A<br>220V / 5A | 0 – lag1 kvar<br>(0 – lag500 var)<br>lead1 – lag1 kvar<br>(lead500 – lag 500 var)<br>0 – lag2 kvar<br>lead2 – lag2 kvar |
| Power factor            |               | —  | lead 50 – 100 – lag 50 %  |
| Frequency               |               | —  | 45.0 – 55.0 Hz<br>55.0 – 65.0 Hz<br>45.0 – 65.0 Hz  |
| Max. zero-phase voltage |               | 63.5V<br>110.0V<br>190.5V                        | 0 – 86.6V<br>0 – 150.0V<br>0 – 259.8V   |
| Demand                  |               | 5A   | 0 – 5A, element S   |
| Maximum demand          |               | 5A   | 0 – 5A, element S   |

Remarks:

- 1) Values for single-phase connection in brackets.
- 2) Displays are automatically scaled according to the scaling factor settings for VT and CT.
- 3) Reverse or lead flow are displayed with the negative (–) indicator.

## INSTALLATION

### Auxiliary power supply

**AC:** operational voltage range 85 – 264V, 50/60 Hz, approx. 5.5VA

**DC:** operational voltage range for R: 24V ±10% or P: 85 – 143V; ripple 10% p-p max.; approx. 5.5W (approx. 230mA at 24V)

**Operating temperature:** -10 to +50°C (14 to 122°F)

**Operating humidity:** 30 to 85% RH (non-condensing)

**Grounding:** grounding resistance ≤100Ω

**Mounting:** panel flush mounting

**Dimensions:** W110×H110×D126 mm (4.33"×4.33"×4.96")

**Weight:** 500 g (1.10 lbs)

## PERFORMANCE in percentage of span

### Accuracy

**Voltage, current:** ±1.0%

**Watt, var:** ±1.5%

**Power factor:** ±3.0%

**Frequency:** ±0.5%

**Demand:** ±1.5%

**Zero-phase voltage:** ±1.5%

**Max. zero-phase voltage:** ±1.5%

**Watthours:** ±2.0% (load current 5 – 100%, power factor 1.0)  
±2.5% (load current 10 – 100%, power factor 0.5, lag current)

**Varhours:** ±2.5% (load current 10 – 100%, power factor 0)  
±2.5% (load current 20 – 100%, power factor 0.866)  
±3.0% (load current 10%, power factor 0.866)

**Temp. conditioning incl. in the accuracy:** 23 ±10°C (73.4 ±18°F)

**Freq. conditioning incl. in the accuracy:** 45 – 65 Hz

**Response time:** ≤2 sec. (0 – 100% ±1%)

**Ripple:** 0.5% p-p max.

**Auxiliary supply voltage effect:** ±0.1% over voltage range

**Power failure protection:** VT/CT scaling factors, watthours, max. zero-phase voltage and demand are stored in non-volatile memory.

**Insulation resistance:** ≥100MΩ with 500V DC

**Dielectric strength:** 2000V AC @1 minute  
(voltage input to current input to transmission section to display switch input to aux. power to ground terminal)  
2000V AC @1 minute  
(circuit to ground terminal; not applicable to analog or transmission terminal)

**Surge withstand voltage:** 1.2/50 μsec., ±4.5kV  
(input to output or ground; not applicable to analog or transmission terminal)

## FRONT PANEL CONFIGURATION

The front display configuration varies according to model numbers (display items).

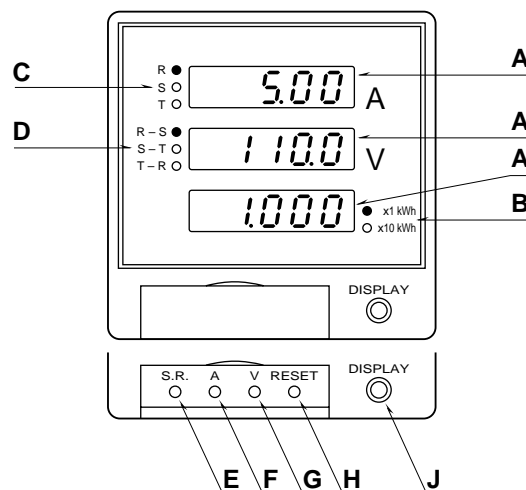

### A. Display

**LED:** 10 mm (.39") 7 segment, orange

**Display items:**

| DISPLAY ITEMS         | NO. OF DIGITS   | REMARKS |  |
|-----------------------|-----------------|---------|--|
| Current               | A (1, N, 2)     | 4       | Single-phase / 3-wire  |
|                       | A (R, S, T)     | 4       | 3-phase / 3-wire or 4-wire                                     |
| Voltage               | V (RS, ST, TR)  | 4       | 3-phase / 3-wire or 4-wire                                     |
|                       | V (RN, SN, TN)  | 4       | 3-phase / 4-wire   |
| Watt                  | kW              | 4       | – indicator (reverse flow),<br>×1, ×10 scaling factor ind. LED |
| Watthours             | kWh             | 5       | ×1, ×10, ×100 scaling factor LED                               |
| Var                   | kvar            | 4       | – indicator (lead),<br>×1, ×10 scaling factor ind. LED         |
| Varhours              | kvarh           | 5       | ×1, ×10, ×100 scaling factor LED                               |
| Power factor          | PF              | 3       | – indicator (lead)   |
| Frequency             | Hz              | 3       |  |
| Zero-phase voltage    | V <sub>0</sub>  | 4       |  |
| Max. zero-phase volt. | MV <sub>0</sub> | 4       |  |
| Demand                | DA              | 4       | Measuring/displaying<br>preset element only                    |
| Max. demand           | MDA             | 4       |  |

When values exceed the preset values, corresponding LEDs blink.

**B. Multiplication factor:** watt, watthours, var or varhours on the display (A)

**C. Line current indicators:** Pressing DISPLAY (J) or "A" (F) button changes lines (elements).

**D. Line current indicators:** Pressing DISPLAY (J) or "V" (G) button changes lines.

**E. Primary rating:** indicating the primary rating of current, voltage, watt or demand

**F. Line current switch**

**G. Line voltage switch**

**H. Reset:** resetting the max. zero-phase voltage or max. demand; same as the external reset input via output terminals

**J. Display:** changing display items, turning the light on or off; same as the Dis. input via output terminals

**EXTERNAL DIMENSIONS mm (inch)**

**■ SINGLE-PHASE / 2-WIRE or 3-WIRE, 3-PHASE / 3-WIRE CONNECTION**

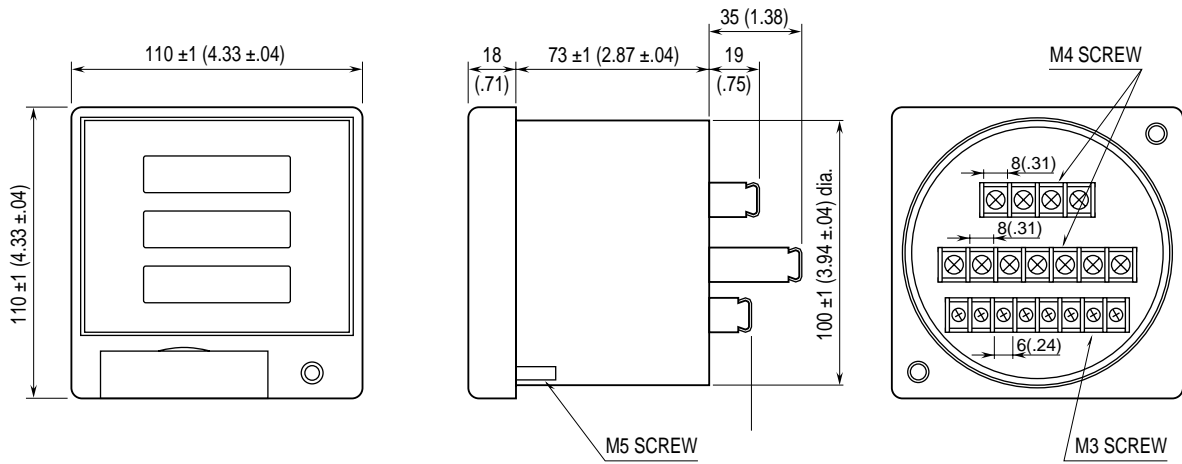

**■ 3-PHASE / 4-WIRE CONNECTION**

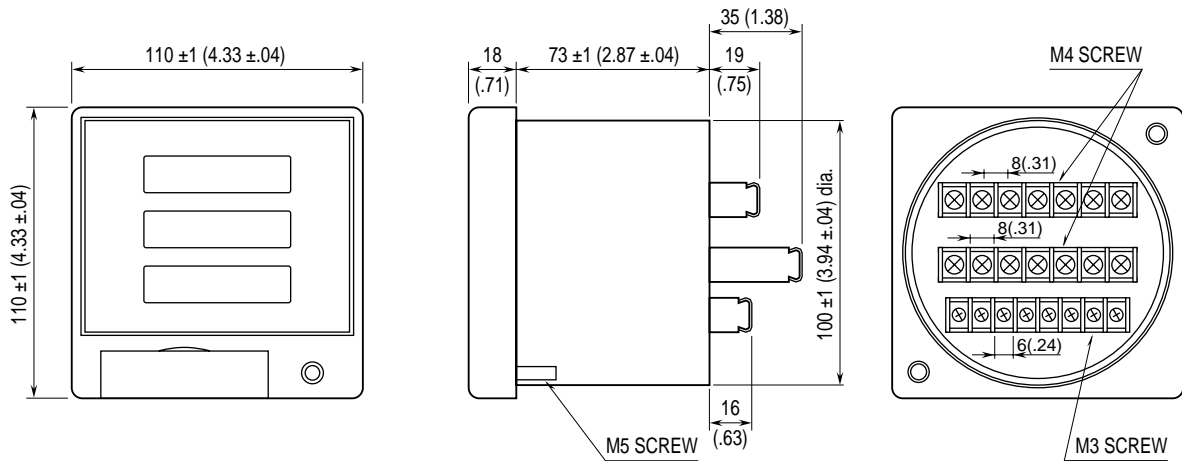

**MOUNTING REQUIREMENTS mm (inch)**

**■ PANEL CUTOUT**

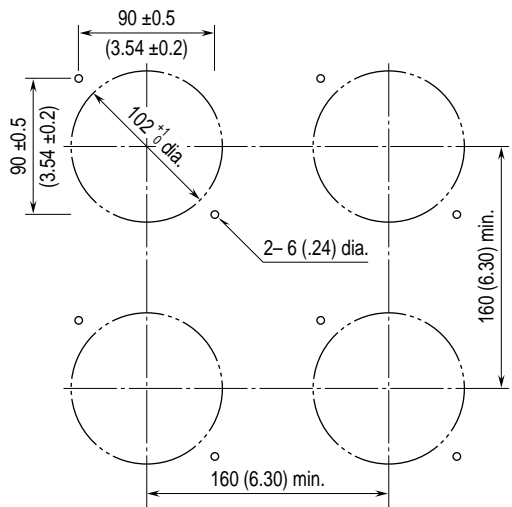

Panel Thickness: 1 to 5.5 mm (.04 - .22 in.)

Specifications subject to change without notice.

# SINGLE-PHASE / 2-WIRE CONNECTION

MODEL **51U-0**

## MODEL & SUFFIX CODE SELECTION

51U-0□□-□□

MODEL

INPUT (balanced)

0 : Single-phase / 2-wire, 105V / 5AAC

DISPLAY ITEMS

C : A, V

D : A, V, kW

E : A, V, kWh

F : A, kW, kWh

J : A, DA, MDA

K : A or DA, MDA, alarm setpoint

N : V, kW, kWh

P : A or DA or MDA, V, kWh

U : V, Hz

W : A or DA or MDA, V, alarm setpoint

V = Line voltage      A = Line current  
 kW = Kilowatt      kWh = Kilowatthours  
 Hz = Frequency  
 DA = Demand (current)  
 MDA = Maximum demand (current)

OUTPUT (selectable display items codes)

0 : None (J K W with reset input)

1 : 4 – 20mA DC, 3 points (C D U)

2 : 4 – 20mA DC, 2 points + pulse (E F N P)

3 : 4 – 20mA DC, 2 points + reset input (J)

4 : RS-485 (all codes selectable except K W)

AUXILIARY POWER SUPPLY

M : 85 – 264V AC

R : 24V DC

P : 110V DC

REMOTE CONTROL

1 : 85 – 132V AC or 85 – 143V DC

2 : 20 – 30V DC

3 : 170 – 264V AC

## ORDERING INFORMATION

Specify code number. (e.g. 51U-0D4-M1)

## CONNECTION DIAGRAM

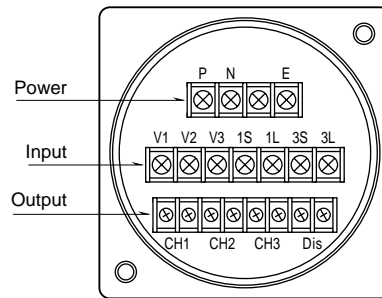

### POWER

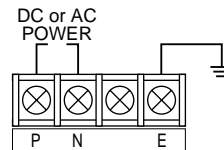

### INPUT

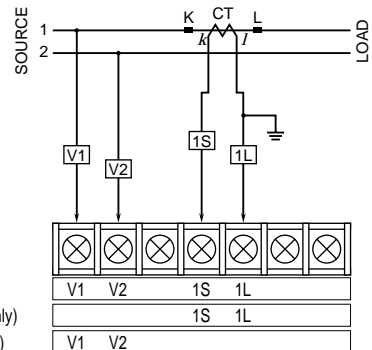

#### Suffix Codes

C, D, E, F, N, P, W  
 J, K (measuring current only)  
 U (measuring voltage only)

### OUTPUT

#### Without Outputs

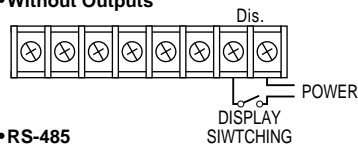

• 4 – 20mA DC, 3 points  
 (See the following pages.)

• 4 – 20mA DC, 2 points  
 + pulse 1 point  
 (See the following pages.)

#### RS-485

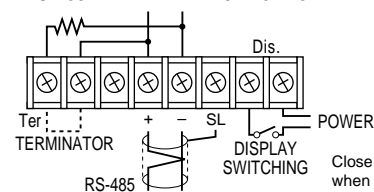

• 4 – 20mA DC, 2 points  
 + reset input  
 (See the following pages.)

Close across the terminator when the unit is located at the end of transmission line.

## DISPLAY ITEMS & OUTPUTS

Items shown in brackets can be displayed when you change settings.

**Suffix Code: C**

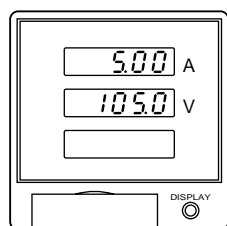

•Output Connection

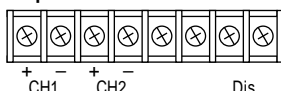

| TERM. | ITEMS                |
|-------|----------------------|
| CH1   | A                    |
| CH2   | V                    |
| Dis.  | Display switch. inp. |

**Suffix Code: D**

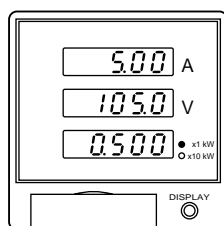

•Output Connection

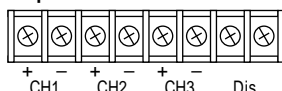

| TERM. | ITEMS                          |
|-------|--------------------------------|
| CH1   | A                              |
| CH2   | V                              |
| CH3   | 0 – 0.5 kW<br>(-0.5 – +0.5 kW) |
| Dis.  | Display switch. inp.           |

**Suffix Code: E**

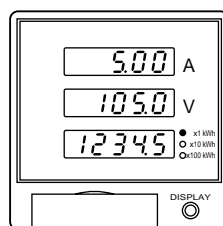

•Output Connection

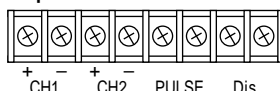

| TERM. | ITEMS                |
|-------|----------------------|
| CH1   | A                    |
| CH2   | V                    |
| PULSE | kWh                  |
| Dis.  | Display switch. inp. |

**Suffix Code: F**

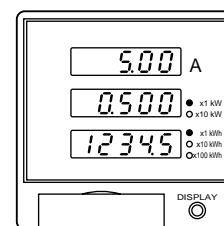

•Output Connection

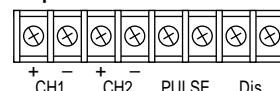

| TERM. | ITEMS                          |
|-------|--------------------------------|
| CH1   | A                              |
| CH2   | 0 – 0.5 kW<br>(-0.5 – +0.5 kW) |
| PULSE | kWh                            |
| Dis.  | Display switch. inp.           |

**Suffix Code: J**

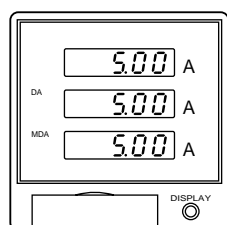

•Output Connection



| TERM. | ITEMS                |
|-------|----------------------|
| CH1   | A                    |
| CH2   | DA (MDA)             |
| RESET | MDA ext. reset inp.  |
| Dis.  | Display switch. inp. |

**Suffix Code: K**

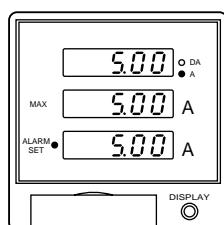

•Output Connection



| TERM. | ITEMS                |
|-------|----------------------|
| ALARM | DA alarm output      |
| RESET | MDA ext. reset inp.  |
| Dis.  | Display switch. inp. |

**Suffix Code: N**

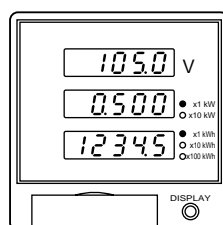

•Output Connection

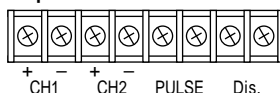

| TERM.       | ITEMS                          |
|-------------|--------------------------------|
| CH1         | V                              |
| CH2         | 0 – 0.5 kW<br>(-0.5 – +0.5 kW) |
| CH1/CH2 (A) |                                |
| PULSE       | kWh                            |
| Dis.        | Display switch. inp.           |

**Suffix Code: P**

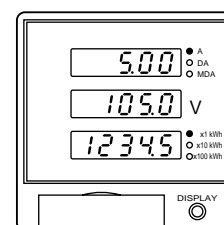

•Output Connection

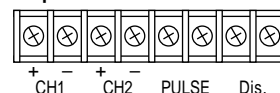

| TERM.   | ITEMS                |
|---------|----------------------|
| CH1     | A                    |
| CH2     | V                    |
| CH1/CH2 | (DA, MDA)            |
| PULSE   | kWh                  |
| Dis.    | Display switch. inp. |

**Suffix Code: U**

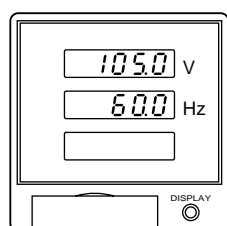

•Output Connection

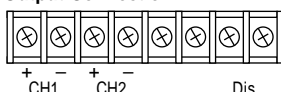

| TERM. | ITEMS                |
|-------|----------------------|
| CH1   | V                    |
| CH2   | Hz                   |
| Dis.  | Display switch. inp. |

**Suffix Code: W**

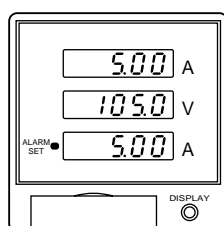

•Output Connection

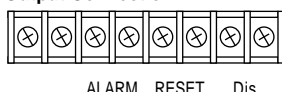

| TERM. | ITEMS                |
|-------|----------------------|
| ALARM | DA alarm output      |
| RESET | MDA ext. reset inp.  |
| Dis.  | Display switch. inp. |

Specifications subject to change without notice.

# SINGLE-PHASE / 3-WIRE CONNECTION

MODEL **51U-1**

## MODEL & SUFFIX CODE SELECTION

51U-1□□-□□

MODEL

INPUT (balanced)

1 : Single-phase / 3-wire, 105V / 210V / 5A AC

DISPLAY ITEMS

A : A × 3

B : V × 3

C : A × 3, V × 3

D : A × 3, V × 3, kW

E : A × 3, V × 3, kWh

F : A × 3, kW, kWh

J : A × 3, DA, MDA

K : A × 3 or DA, MDA, alarm setpoint

L : Hz, PF, kW

M : PF, kW, kWh

N : V × 3, kW, kWh

P : A × 3 or DA or MDA, V × 3, kWh

Q : A × 3, PF, kW

S : A × 3 or PF, kW, kWh

U : V × 3, Hz

W : A × 3 or DA or MDA, V × 3, alarm setpoint

Y : Hz, PF, kWh

|                                |                     |
|--------------------------------|---------------------|
| V = Line voltage               | A = Line current    |
| kW = Kilowatt                  | kWh = Kilowatthours |
| PF = Power factor              | Hz = Frequency      |
| DA = Demand (current)          |                     |
| MDA = Maximum demand (current) |                     |

OUTPUT (selectable display items codes)

0 : None (J K W with reset input)

1 : 4 – 20mA DC, 3 points (A B C D L Q U)

2 : 4 – 20mA DC, 2 points + pulse (E F M N P)

3 : 4 – 20mA DC, 2 points + reset input (J)

4 : RS-485 (all codes selectable except K W)

AUXILIARY POWER SUPPLY

M : 85 – 264V AC

R : 24V DC

P : 110V DC

REMOTE CONTROL

1 : 85 – 132V AC or 85 – 143V DC

2 : 20 – 30V DC

3 : 170 – 264V AC

## ORDERING INFORMATION

Specify code number. (e.g. 51U-1D4-M1)

## CONNECTION DIAGRAM

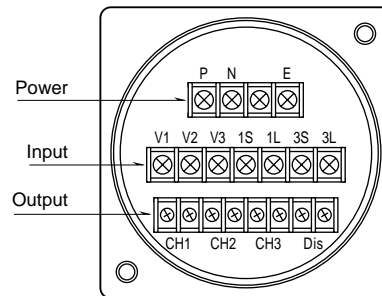

### POWER

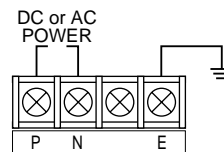

### INPUT

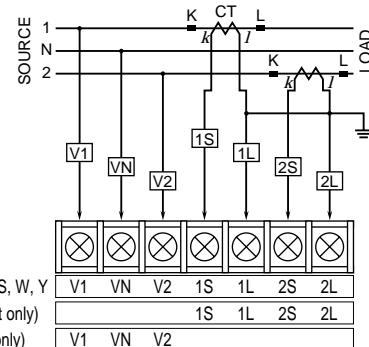

### Suffix Codes

C, D, E, F, L, M, N, P, Q, S, W, Y

A, J, K (measuring current only)

B, U (measuring voltage only)

### OUTPUT

#### Without Outputs

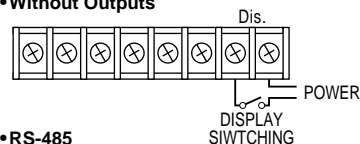

• 4 – 20mA DC, 3 points  
(See the following pages.)

• 4 – 20mA DC, 2 points  
+ pulse 1 point  
(See the following pages.)

#### RS-485

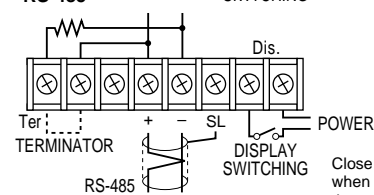

• 4 – 20mA DC, 2 points  
+ reset input  
(See the following pages.)

Close across the terminator when the unit is located at the end of transmission line.

## DISPLAY ITEMS & OUTPUTS

Items shown in brackets can be displayed when you change settings.

Suffix Code: A

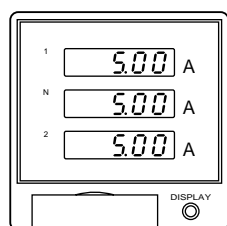

## •Output Connection

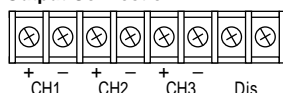

| TERM. | ITEMS                |
|-------|----------------------|
| CH1   | A1                   |
| CH2   | A <sub>N</sub>       |
| CH3   | A <sub>2</sub>       |
| Dis.  | Display switch. inp. |

Suffix Code: B

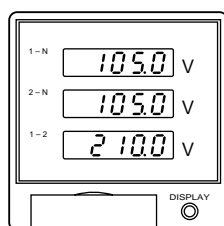

## •Output Connection

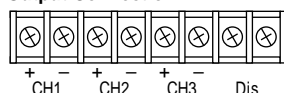

| TERM. | ITEMS                |
|-------|----------------------|
| CH1   | V <sub>1N</sub>      |
| CH2   | V <sub>2N</sub>      |
| CH3   | V <sub>12</sub>      |
| Dis.  | Display switch. inp. |

Suffix Code: C

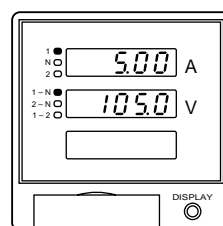

## •Output Connection

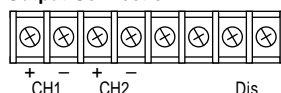

| TERM. | ITEMS  |
|-------|--|
| CH1   | A1 (A <sub>N</sub> , A <sub>2</sub> )                |
| CH2   | V <sub>1N</sub> (V <sub>2N</sub> , V <sub>12</sub> ) |
| Dis.  | Display switch. inp.                                 |

Suffix Code: D

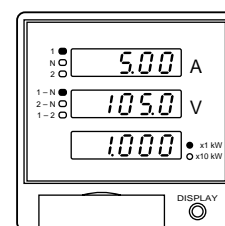

## •Output Connection

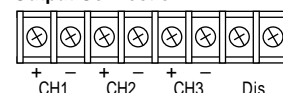

| TERM. | ITEMS  |
|-------|--|
| CH1   | A1 (A <sub>N</sub> , A <sub>2</sub> )                |
| CH2   | V <sub>1N</sub> (V <sub>2N</sub> , V <sub>12</sub> ) |
| CH3   | 0 - 1 kW<br>(-1 - +1 kW)                             |
| Dis.  | Display switch. inp.                                 |

Suffix Code: E

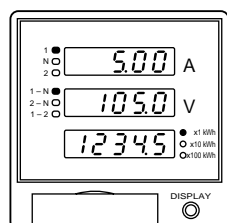

## •Output Connection

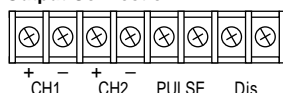

| TERM. | ITEMS  |
|-------|--|
| CH1   | A1 (A <sub>N</sub> , A <sub>2</sub> )                |
| CH2   | V <sub>1N</sub> (V <sub>2N</sub> , V <sub>12</sub> ) |
| PULSE | kWh  |
| Dis.  | Display switch. inp.                                 |

Suffix Code: F

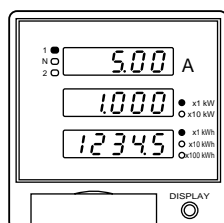

## •Output Connection

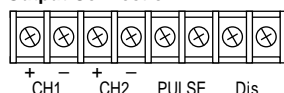

| TERM. | ITEMS                                 |
|-------|---------------------------------------|
| CH1   | A1 (A <sub>N</sub> , A <sub>2</sub> ) |
| CH2   | 0 - 1 kW<br>(-1 - +1 kW)              |
| PULSE | kWh                                   |
| Dis.  | Display switch. inp.                  |

Suffix Code: J

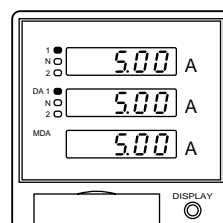

## •Output Connection

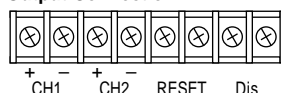

| TERM. | ITEMS                                 |
|-------|---------------------------------------|
| CH1   | A1 (A <sub>N</sub> , A <sub>2</sub> ) |
| CH2   | DA (MDA)                              |
| RESET | MDA ext. reset inp.                   |
| Dis.  | Display switch. inp.                  |

Suffix Code: K

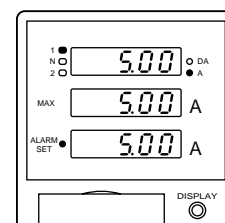

## •Output Connection



| TERM. | ITEMS                |
|-------|----------------------|
| ALARM | DA alarm output      |
| RESET | MDA ext. reset inp.  |
| Dis.  | Display switch. inp. |

Suffix Code: L

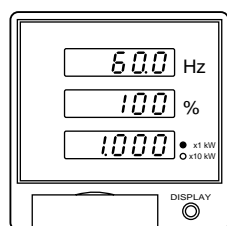

## •Output Connection

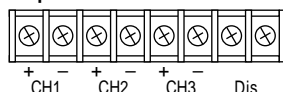

| TERM. | ITEMS                    |
|-------|--------------------------|
| CH1   | Hz                       |
| CH2   | PF                       |
| CH3   | 0 - 1 kW<br>(-1 - +1 kW) |
| Dis.  | Display switch. inp.     |

Suffix Code: M

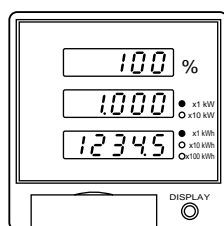

## •Output Connection

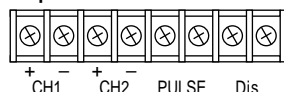

| TERM. | ITEMS                    |
|-------|--------------------------|
| CH1   | PF                       |
| CH2   | 0 - 1 kW<br>(-1 - +1 kW) |
| PULSE | kWh                      |
| Dis.  | Display switch. inp.     |

Suffix Code: N

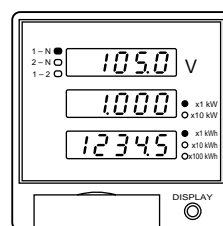

## •Output Connection

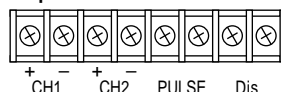

| TERM.   | ITEMS  |
|---------|--|
| CH1     | V <sub>1N</sub> (V <sub>2N</sub> , V <sub>12</sub> ) |
| CH2     | 0 - 1 kW<br>(-1 - +1 kW)                             |
| CH1/CH2 | (A1, A <sub>N</sub> , A <sub>2</sub> )               |
| PULSE   | kWh  |
| Dis.    | Display switch. inp.                                 |

Suffix Code: P

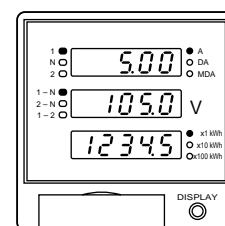

## •Output Connection

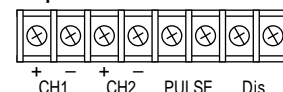

| TERM.   | ITEMS  |
|---------|--|
| CH1     | A1 (A <sub>N</sub> , A <sub>2</sub> )                |
| CH2     | V <sub>1N</sub> (V <sub>2N</sub> , V <sub>12</sub> ) |
| CH1/CH2 | (DA, MDA)  |
| PULSE   | kWh  |
| Dis.    | Display switch. inp.                                 |

Specifications subject to change without notice.



**Suffix Code: Q**

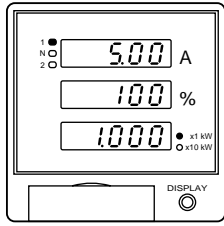

**•Output Connection**

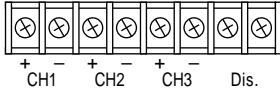

| TERM. | ITEMS                    |
|-------|--------------------------|
| CH1   | A1 (AN, A2)              |
| CH2   | PF                       |
| CH3   | 0 – 1 kW<br>(-1 – +1 kW) |
| Dis.  | Display switch. inp.     |

**Suffix Code: S**

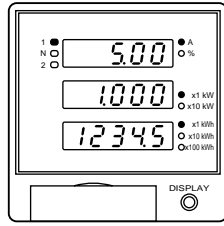

**•Output Connection**

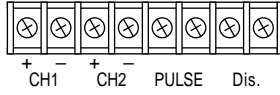

| TERM.   | ITEMS                    |
|---------|--------------------------|
| CH1     | A1 (AN, A2)              |
| CH2     | 0 – 1 kW<br>(-1 – +1 kW) |
| CH1/CH2 | (PF)                     |
| PULSE   | kWh                      |
| Dis.    | Display switch. inp.     |

**Suffix Code: U**

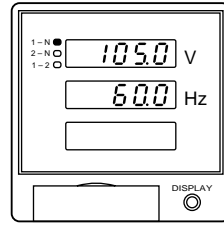

**•Output Connection**

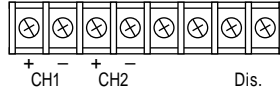

| TERM. | ITEMS  |
|-------|--|
| CH1   | V <sub>1N</sub> (V <sub>2N</sub> , V <sub>12</sub> ) |
| CH2   | Hz   |
| Dis.  | Display switch. inp.                                 |

**Suffix Code: W**

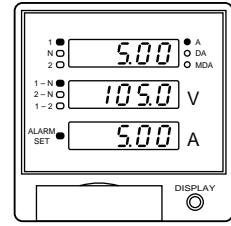

**•Output Connection**



| TERM. | ITEMS                |
|-------|----------------------|
| ALARM | DA alarm output      |
| RESET | MDA ext. reset inp.  |
| Dis.  | Display switch. inp. |

**Suffix Code: Y**

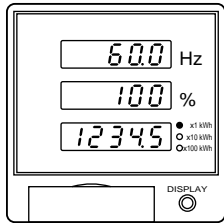

**•Output Connection**

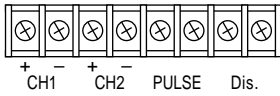

| TERM. | ITEMS                |
|-------|----------------------|
| CH1   | Hz                   |
| CH2   | PF                   |
| PULSE | kWh                  |
| Dis.  | Display switch. inp. |

# THREE-PHASE / 3-WIRE CONNECTION

# MODEL 51U-2 / 51U-3

## MODEL & SUFFIX CODE SELECTION

51U-□□□-□□

MODEL

INPUT (balanced)

2 : Three-phase / 3-wire, 220V / 5A AC

3 : Three-phase / 3-wire, 110V / 5A AC

DISPLAY ITEMS

A : A × 3

B : V × 3

C : A × 3, V × 3

D : A × 3, V × 3, kW

E : A × 3, V × 3, kWh

F : A × 3, kW, kWh

G : Hz, PF, kvar

H : V × 3, MV<sub>0</sub>, V<sub>0</sub>

J : A × 3, DA, MDA

K : A × 3 or DA, MDA, alarm setpoint

L : Hz, PF, kW

M : PF, kW, kWh

N : V × 3, kW, kWh

P : A × 3 or DA or MDA, V × 3, kWh

Q : A × 3, PF, kW

R : A × 3, PF, kvar

S : A × 3 or PF, kW, kWh

T : A × 3, PF, kvarh

U : V × 3, Hz

W : A × 3 or DA or MDA, V × 3, alarm setpoint

X : A × 3, kvar, kvarh

Y : Hz, PF, kWh

|  |                      |
|--|----------------------|
| V = Line voltage                             | A = Line current     |
| kW = Kilowatt                                | kvar = Kilovar       |
| PF = Power factor                            | Hz = Frequency       |
| kWh = Kilowatthours                          | kvarh = Kilovarhours |
| DA = Demand (current)                        |                      |
| MDA = Maximum demand (current)               |                      |
| V <sub>0</sub> = Zero-phase voltage          |                      |
| MV <sub>0</sub> = Maximum zero-phase voltage |                      |

OUTPUT (selectable display items codes)

0 : None (H J K W with reset input)

1 : 4 – 20mA DC, 3 points (A B C D G L Q R U)

2 : 4 – 20mA DC, 2 points + pulse  
(E F M N P S T X Y)

3 : 4 – 20mA DC, 2 points + reset input (H J)

4 : RS-485 (all codes selectable except K W)

AUXILIARY POWER SUPPLY

M : 85 – 264V AC

R : 24V DC

P : 110V DC

REMOTE CONTROL

1 : 85 – 132V AC or 85 – 143V DC

2 : 20 – 30V DC

3 : 170 – 264V AC

## ORDERING INFORMATION

Specify code number. (e.g. 51U-2D4-M1)

## CONNECTION DIAGRAM

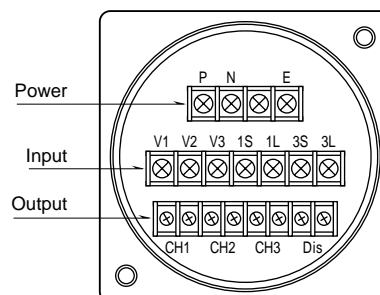

### ■ POWER

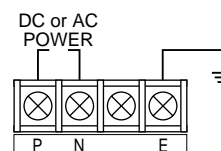

### ■ INPUT

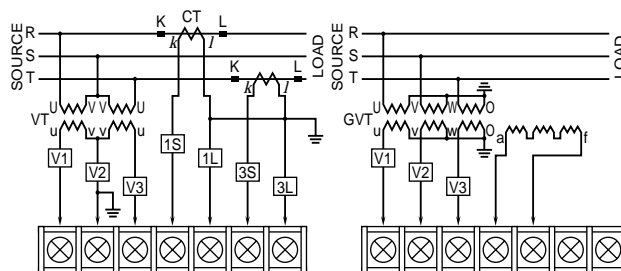

#### Suffix Codes

|  |    |    |    |    |    |    |
|--|----|----|----|----|----|----|
| V1   | V2 | V3 | 1S | 1L | 3S | 3L |
| C, D, E, F, G, L, M, N, P, Q, R, S, T, W, X, Y |    |    |    |    |    |    |
| 1S 1L 3S 3L                                    |    |    |    |    |    |    |
| A, J, K (measuring current only)               |    |    |    |    |    |    |
| V1 V2 V3                                       |    |    |    |    |    |    |
| B, U (measuring voltage only)                  |    |    |    |    |    |    |

|    |    |    |    |    |
|----|----|----|----|----|
| V1 | V2 | V3 | G1 | G4 |
|----|----|----|----|----|

H (measuring max. zero-phase voltage)

220V AC can be directly connected to V1, V2 and V3 terminals without VT.

### ■ OUTPUT

#### • Without Outputs

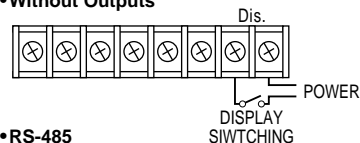
• 4 – 20mA DC, 3 points  
(See the following pages.)• 4 – 20mA DC, 2 points  
+ pulse 1 point  
(See the following pages.)

#### • RS-485

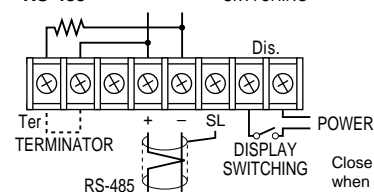
• 4 – 20mA DC, 2 points  
+ reset input  
(See the following pages.)

Close across the terminator when the unit is located at the end of transmission line.

## DISPLAY ITEMS & OUTPUTS

Items shown in brackets can be displayed when you change settings.

Suffix Code: A

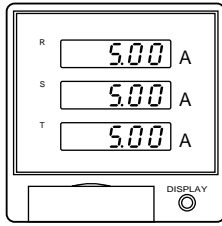

•Output Connection

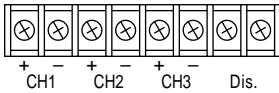

| TERM. | ITEMS                |
|-------|----------------------|
| CH1   | AR                   |
| CH2   | As                   |
| CH3   | AT                   |
| Dis.  | Display switch. inp. |

Suffix Code: B

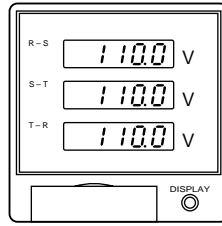

•Output Connection

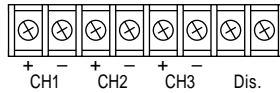

| TERM. | ITEMS                |
|-------|----------------------|
| CH1   | VRS                  |
| CH2   | VST                  |
| CH3   | VTR                  |
| Dis.  | Display switch. inp. |

Suffix Code: C

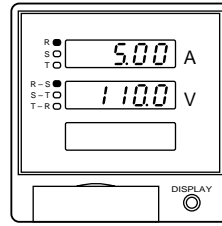

•Output Connection

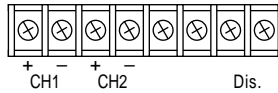

| TERM. | ITEMS                |
|-------|----------------------|
| CH1   | AR (As, AT)          |
| CH2   | VRS (VST, VTR)       |
| Dis.  | Display switch. inp. |

Suffix Code: D

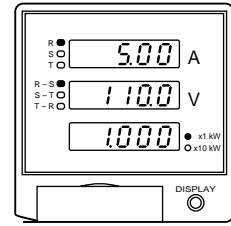

•Output Connection

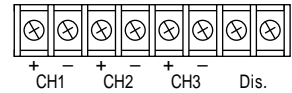

| TERM. | ITEMS                    |
|-------|--------------------------|
| CH1   | AR (As, AT)              |
| CH2   | VRS (VST, VTR)           |
| CH3   | 0 - 1 kW<br>(-1 - +1 kW) |
| Dis.  | Display switch. inp.     |

Suffix Code: E

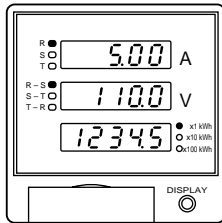

•Output Connection

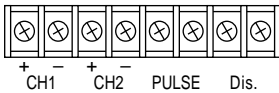

| TERM. | ITEMS                |
|-------|----------------------|
| CH1   | AR (As, AT)          |
| CH2   | VRS (VST, VTR)       |
| PULSE | kWh                  |
| Dis.  | Display switch. inp. |

Suffix Code: F

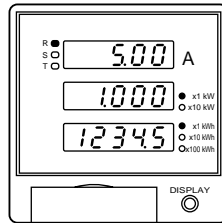

•Output Connection

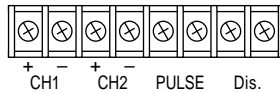

| TERM. | ITEMS                    |
|-------|--------------------------|
| CH1   | AR (As, AT)              |
| CH2   | 0 - 1 kW<br>(-1 - +1 kW) |
| PULSE | kWh                      |
| Dis.  | Display switch. inp.     |

Suffix Code: G

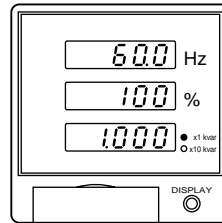

•Output Connection

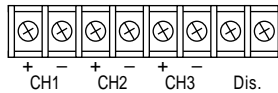

| TERM. | ITEMS                                |
|-------|--------------------------------------|
| CH1   | Hz                                   |
| CH2   | PF                                   |
| CH3   | 0 - lag1 kvar<br>(lead1 - lag1 kvar) |
| Dis.  | Display switch. inp.                 |

Suffix Code: H

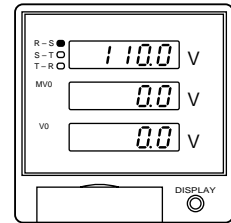

•Output Connection

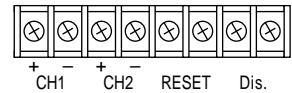

| TERM. | ITEMS                |
|-------|----------------------|
| CH1   | VRS (VST, VTR)       |
| CH2   | MV0                  |
| RESET | MV0 ext. reset inp.  |
| Dis.  | Display switch. inp. |

Suffix Code: J

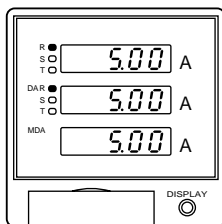

•Output Connection

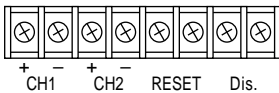

| TERM. | ITEMS                |
|-------|----------------------|
| CH1   | AR (As, AT)          |
| CH2   | DA (MDA)             |
| RESET | MDA ext. reset inp.  |
| Dis.  | Display switch. inp. |

Suffix Code: K

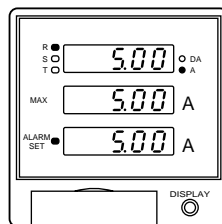

•Output Connection



| TERM. | ITEMS                |
|-------|----------------------|
| ALARM | DA alarm output      |
| RESET | MDA ext. reset inp.  |
| Dis.  | Display switch. inp. |

Suffix Code: L

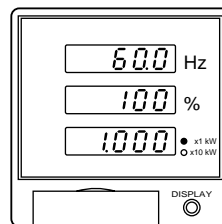

•Output Connection

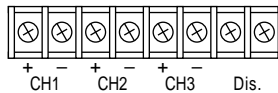

| TERM. | ITEMS                    |
|-------|--------------------------|
| CH1   | Hz                       |
| CH2   | PF                       |
| CH3   | 0 - 1 kW<br>(-1 - +1 kW) |
| Dis.  | Display switch. inp.     |

Suffix Code: M

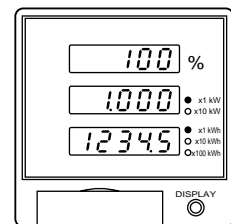

•Output Connection

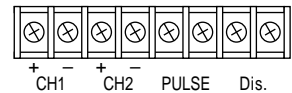

| TERM. | ITEMS                    |
|-------|--------------------------|
| CH1   | PF                       |
| CH2   | 0 - 1 kW<br>(-1 - +1 kW) |
| PULSE | kWh                      |
| Dis.  | Display switch. inp.     |

**Suffix Code: N**

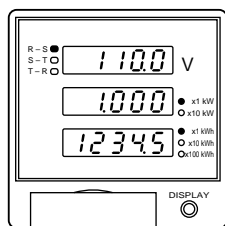

•Output Connection

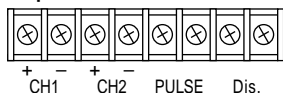

| TERM.   | ITEMS                    |
|---------|--------------------------|
| CH1     | VRS (VST, VTR)           |
| CH2     | 0 – 1 kW<br>(-1 – +1 kW) |
| CH1/CH2 | (AR, AS, AT)             |
| PULSE   | kWh                      |
| Dis.    | Display switch. inp.     |

**Suffix Code: P**

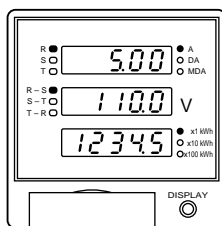

•Output Connection



| TERM.   | ITEMS                |
|---------|----------------------|
| CH1     | AR (AS, AT)          |
| CH2     | VRS (VST, VTR)       |
| CH1/CH2 | (DA, MDA)            |
| PULSE   | kWh                  |
| Dis.    | Display switch. inp. |

**Suffix Code: Q**

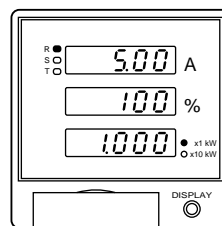

•Output Connection

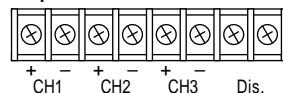

| TERM. | ITEMS                    |
|-------|--------------------------|
| CH1   | AR (AS, AT)              |
| CH2   | PF                       |
| CH3   | 0 – 1 kW<br>(-1 – +1 kW) |
| Dis.  | Display switch. inp.     |

**Suffix Code: R**

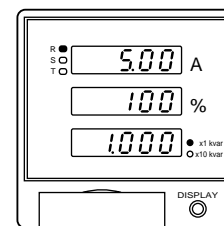

•Output Connection

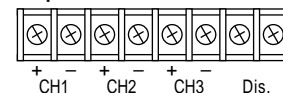

| TERM. | ITEMS                                |
|-------|--------------------------------------|
| CH1   | AR (AS, AT)                          |
| CH2   | PF                                   |
| CH3   | 0 – lag1 kvar<br>(lead1 – lag1 kvar) |
| Dis.  | Display switch. inp.                 |

**Suffix Code: S**

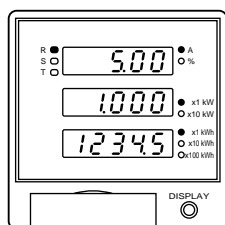

•Output Connection

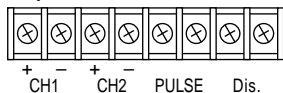

| TERM.   | ITEMS                    |
|---------|--------------------------|
| CH1     | AR (AS, AT)              |
| CH2     | 0 – 1 kW<br>(-1 – +1 kW) |
| CH1/CH2 | (PF)                     |
| PULSE   | kWh                      |
| Dis.    | Display switch. inp.     |

**Suffix Code: T**

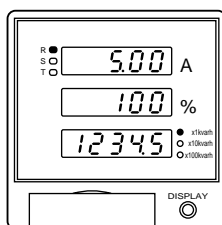

•Output Connection

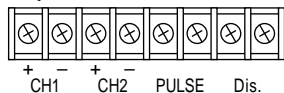

| TERM. | ITEMS                |
|-------|----------------------|
| CH1   | AR (AS, AT)          |
| CH2   | PF                   |
| PULSE | kvarh                |
| Dis.  | Display switch. inp. |

**Suffix Code: U**

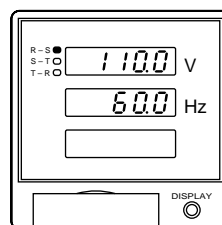

•Output Connection

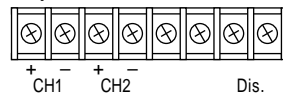

| TERM. | ITEMS                |
|-------|----------------------|
| CH1   | VRS (VST, VTR)       |
| CH2   | Hz                   |
| Dis.  | Display switch. inp. |

**Suffix Code: W**

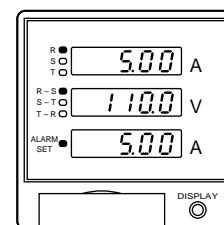

•Output Connection



| TERM. | ITEMS                |
|-------|----------------------|
| ALARM | DA alarm output      |
| RESET | MDA ext. reset inp.  |
| Dis.  | Display switch. inp. |

**Suffix Code: X**

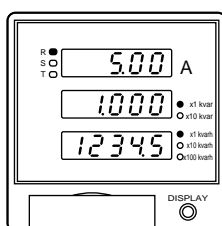

•Output Connection

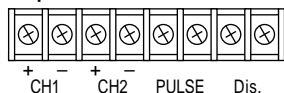

| TERM. | ITEMS                                |
|-------|--------------------------------------|
| CH1   | AR (AS, AT)                          |
| CH2   | 0 – lag1 kvar<br>(lead1 – lag1 kvar) |
| PULSE | kvarh                                |
| Dis.  | Display switch. inp.                 |

**Suffix Code: Y**

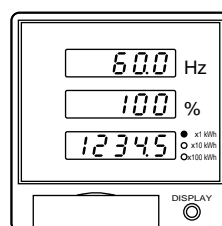

•Output Connection

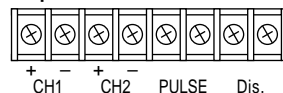

| TERM. | ITEMS                |
|-------|----------------------|
| CH1   | Hz                   |
| CH2   | PF                   |
| PULSE | kWh                  |
| Dis.  | Display switch. inp. |

# THREE-PHASE / 4-WIRE CONNECTION

MODEL **51U-4**

## MODEL & SUFFIX CODE SELECTION

51U-4□□-□□

MODEL \_\_\_\_\_

INPUT (balanced) \_\_\_\_\_

4 : 3-phase / 4-wire, 110V /  $\sqrt{3}$  V / 5A AC

DISPLAY ITEMS \_\_\_\_\_

A : A × 3

B : V × 3

C : A × 3, V × 3

D : A × 3, V × 3, kW

E : A × 3, V × 3, kWh

F : A × 3, kW, kWh

G : Hz, PF, kvar

J : A × 3, DA, MDA

L : Hz, PF, kW

M : PF, kW, kWh

N : V × 3, kW, kWh

P : A × 3 or DA or MDA, V × 3, kWh

Q : A × 3, PF, kW

R : A × 3, PF, kvar

S : A × 3 or PF, kW, kWh

T : A × 3, PF, kvarh

U : V × 3, Hz

X : A × 3, kvar, kvarh

Y : Hz, PF, kWh

|  |                      |
|--|----------------------|
| V = Line voltage                             | A = Line current     |
| kW = Kilowatt                                | kvar = Kilovar       |
| PF = Power factor                            | Hz = Frequency       |
| kWh = Kilowatthours                          | kvarh = Kilovarhours |
| DA = Demand (current)                        |                      |
| MDA = Maximum demand (current)               |                      |
| V <sub>0</sub> = Zero-phase voltage          |                      |
| MV <sub>0</sub> = Maximum zero-phase voltage |                      |

OUTPUT (selectable display items codes) \_\_\_\_\_

0 : None (J with reset input)

1 : 4 – 20mA DC, 3 points (A B C D G L Q R U)

2 : 4 – 20mA DC, 2 points + pulse  
(E F M N P S T X Y)

3 : 4 – 20mA DC, 2 points + reset input (J)

4 : RS-485

AUXILIARY POWER SUPPLY \_\_\_\_\_

M : 85 – 264V AC

R : 24V DC

P : 110V DC

REMOTE CONTROL \_\_\_\_\_

1 : 85 – 132V AC or 85 – 143V DC

2 : 20 – 30V DC

3 : 170 – 264V AC

## ORDERING INFORMATION

Specify code number. (e.g. 51U-4D4-M1)

## CONNECTION DIAGRAM

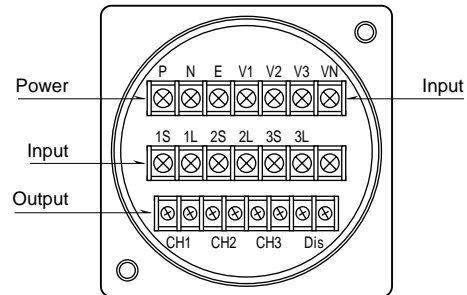

### POWER & INPUT

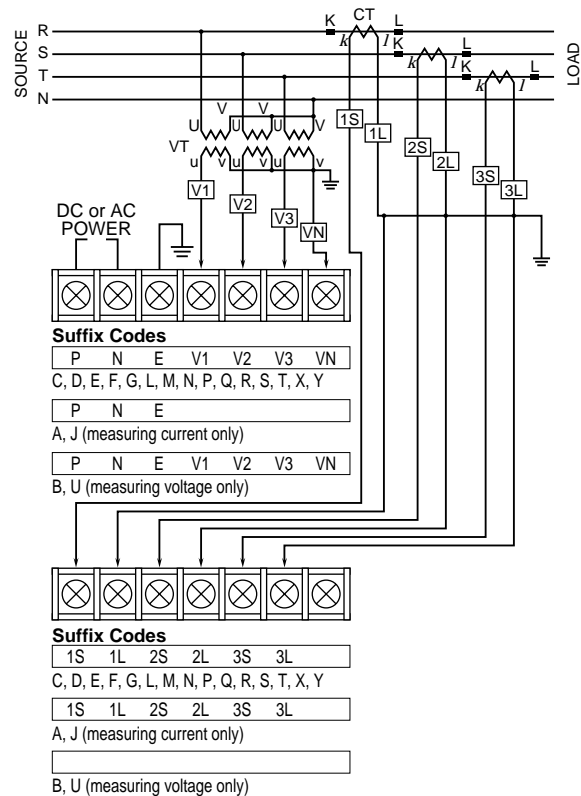

### OUTPUT

#### Without Outputs

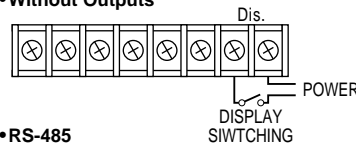

• 4 – 20mA DC, 3 points  
(See the following pages.)

• 4 – 20mA DC, 2 points + pulse 1 point  
(See the following pages.)

#### RS-485

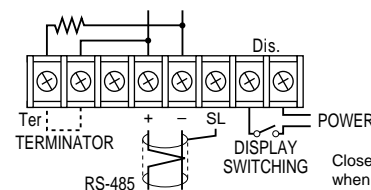

• 4 – 20mA DC, 2 points + reset input  
(See the following pages.)

Close across the terminator when the unit is located at the end of transmission line.

## DISPLAY ITEMS & OUTPUTS

Items shown in brackets can be displayed when you change settings.

Suffix Code: A

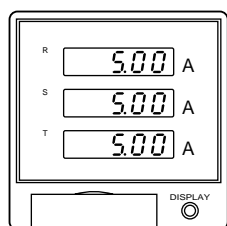

## •Output Connection

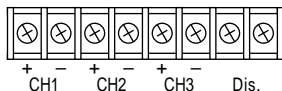

| TERM. | ITEMS                |
|-------|----------------------|
| CH1   | AR                   |
| CH2   | As                   |
| CH3   | AT                   |
| Dis.  | Display switch. inp. |

Suffix Code: B

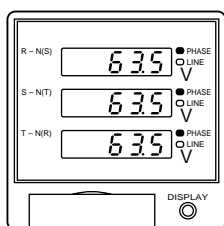

## •Output Connection

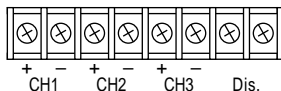

| TERM.   | ITEMS                |
|---------|----------------------|
| CH1     | VRS                  |
| CH2     | VST                  |
| CH3     | VTR                  |
| CH1/2/3 | (VRN, VSN, VTN)      |
| Dis.    | Display switch. inp. |

Suffix Code: C

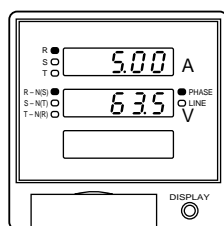

## •Output Connection

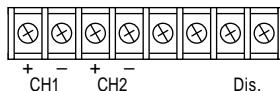

| TERM.   | ITEMS                |
|---------|----------------------|
| CH1     | AR (As, AT)          |
| CH2     | VRS (VST, VTR)       |
| CH1/CH2 | (VRN, VSN, VTN)      |
| Dis.    | Display switch. inp. |

Suffix Code: D

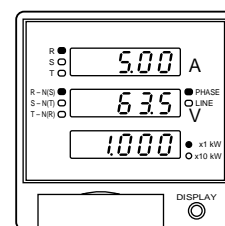

## •Output Connection

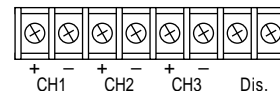

| TERM.   | ITEMS                    |
|---------|--------------------------|
| CH1     | AR (As, AT)              |
| CH2     | VRS (VST, VTR)           |
| CH3     | 0 - 1 kW<br>(-1 - +1 kW) |
| CH1/2/3 | (VRN, VSN, VTN)          |
| Dis.    | Display switch. inp.     |

Suffix Code: E

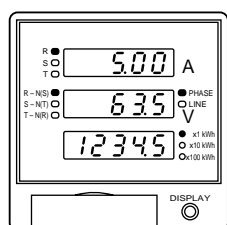

## •Output Connection

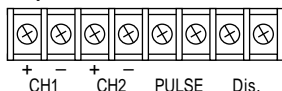

| TERM.   | ITEMS                |
|---------|----------------------|
| CH1     | AR (As, AT)          |
| CH2     | VRS (VST, VTR)       |
| CH1/CH2 | (VRN, VSN, VTN)      |
| PULSE   | kWh                  |
| Dis.    | Display switch. inp. |

Suffix Code: F

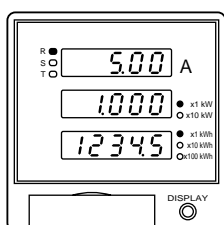

## •Output Connection

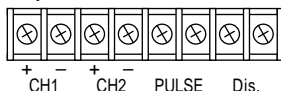

| TERM. | ITEMS                    |
|-------|--------------------------|
| CH1   | AR (As, AT)              |
| CH2   | 0 - 1 kW<br>(-1 - +1 kW) |
| PULSE | kWh                      |
| Dis.  | Display switch. inp.     |

Suffix Code: G

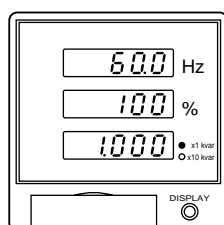

## •Output Connection

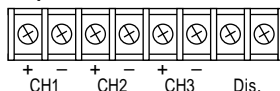

| TERM. | ITEMS                                |
|-------|--------------------------------------|
| CH1   | Hz                                   |
| CH2   | PF                                   |
| CH3   | 0 - lag1 kvar<br>(lead1 - lag1 kvar) |
| Dis.  | Display switch. inp.                 |

Suffix Code: J

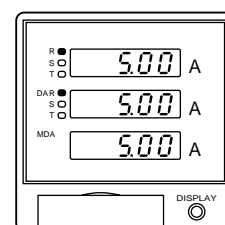

## •Output Connection

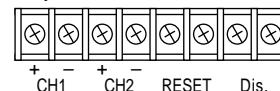

| TERM. | ITEMS                |
|-------|----------------------|
| CH1   | AR (As, AT)          |
| CH2   | DA (MDA)             |
| RESET | MDA ext. reset inp.  |
| Dis.  | Display switch. inp. |

Suffix Code: L

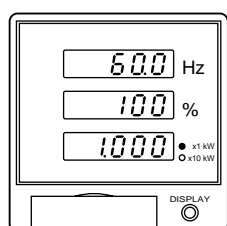

## •Output Connection

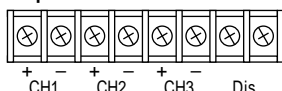

| TERM. | ITEMS                    |
|-------|--------------------------|
| CH1   | Hz                       |
| CH2   | PF                       |
| CH3   | 0 - 1 kW<br>(-1 - +1 kW) |
| Dis.  | Display switch. inp.     |

Suffix Code: M

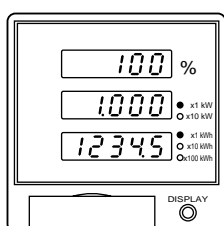

## •Output Connection

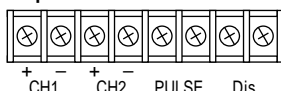

| TERM. | ITEMS                    |
|-------|--------------------------|
| CH1   | PF                       |
| CH2   | 0 - 1 kW<br>(-1 - +1 kW) |
| PULSE | kWh                      |
| Dis.  | Display switch. inp.     |

Suffix Code: N

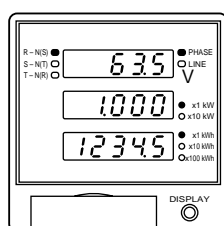

## •Output Connection

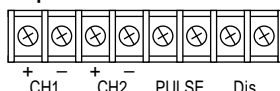

| TERM.   | ITEMS                        |
|---------|------------------------------|
| CH1     | VRS (VST, VTR)               |
| CH2     | 0 - 1 kW<br>(-1 - +1 kW)     |
| CH1/CH2 | (AR, As, AT) (VRN, VSN, VTN) |
| PULSE   | kWh                          |
| Dis.    | Display switch. inp.         |

Suffix Code: P

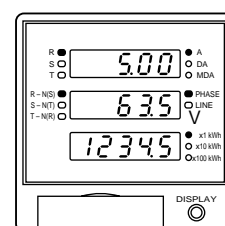

## •Output Connection

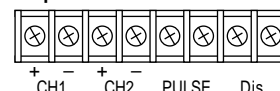

| TERM.   | ITEMS                        |
|---------|------------------------------|
| CH1     | AR (As, AT)                  |
| CH2     | VRS (VST, VTR)               |
| CH1/CH2 | (VRN, VSN, VTN)<br>(DA, MDA) |
| PULSE   | kWh                          |
| Dis.    | Display switch. inp.         |

Specifications subject to change without notice.

**Suffix Code: Q**

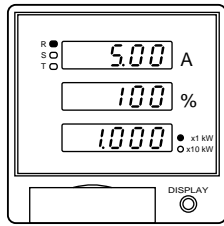

**•Output Connection**

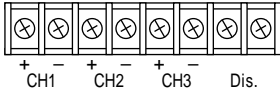

| TERM. | ITEMS                    |
|-------|--------------------------|
| CH1   | AR (As, AT)              |
| CH2   | PF                       |
| CH3   | 0 – 1 kW<br>(-1 – +1 kW) |
| Dis.  | Display switch. inp.     |

**Suffix Code: R**

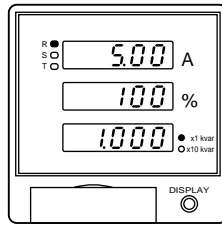

**•Output Connection**

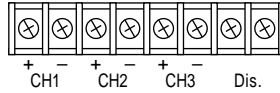

| TERM. | ITEMS                                |
|-------|--------------------------------------|
| CH1   | AR (As, AT)                          |
| CH2   | PF                                   |
| CH3   | 0 – lag1 kvar<br>(lead1 – lag1 kvar) |
| Dis.  | Display switch. inp.                 |

**Suffix Code: S**

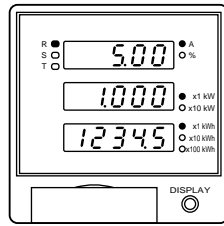

**•Output Connection**

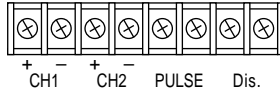

| TERM.   | ITEMS                    |
|---------|--------------------------|
| CH1     | AR (As, AT)              |
| CH2     | 0 – 1 kW<br>(-1 – +1 kW) |
| CH1/CH2 | (PF)                     |
| PULSE   | kWh                      |
| Dis.    | Display switch. inp.     |

**Suffix Code: T**

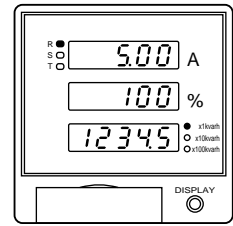

**•Output Connection**

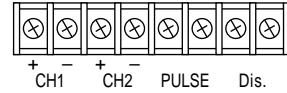

| TERM. | ITEMS                |
|-------|----------------------|
| CH1   | AR (As, AT)          |
| CH2   | PF                   |
| PULSE | kvarh                |
| Dis.  | Display switch. inp. |

**Suffix Code: U**

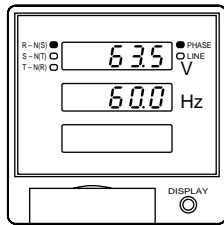

**•Output Connection**

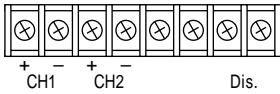

| TERM.   | ITEMS                |
|---------|----------------------|
| CH1     | Vrs (Vst, Vtr)       |
| CH2     | Hz                   |
| CH1/CH2 | (Vrn, Vsn, Vtn)      |
| Dis.    | Display switch. inp. |

**Suffix Code: X**

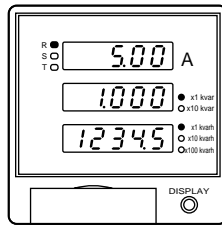

**•Output Connection**

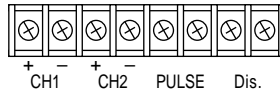

| TERM. | ITEMS                                |
|-------|--------------------------------------|
| CH1   | AR (As, AT)                          |
| CH2   | 0 – lag1 kvar<br>(lead1 – lag1 kvar) |
| PULSE | kvarh                                |
| Dis.  | Display switch. inp.                 |

**Suffix Code: Y**

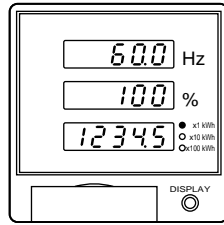

**•Output Connection**

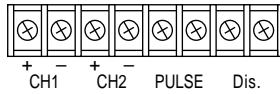

| TERM. | ITEMS                |
|-------|----------------------|
| CH1   | Hz                   |
| CH2   | PF                   |
| PULSE | kWh                  |
| Dis.  | Display switch. inp. |

**SYSTEM CONFIGURATION EXAMPLE**

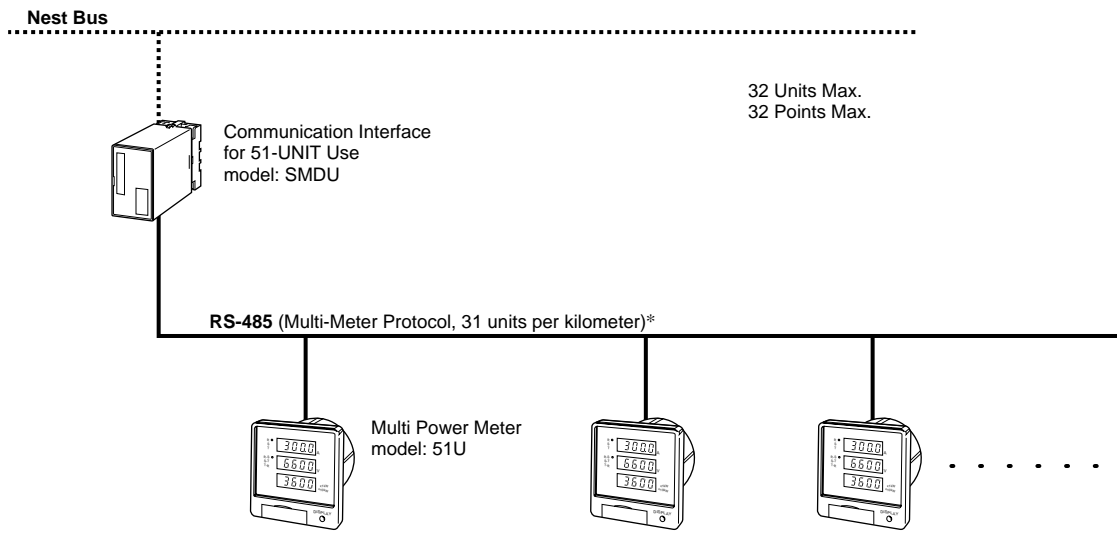

\*MsysNet use only. Consult Factory.