

Customer Information Sheet

DRAWING No.: M22-654XX42R

SHEET 3 OF 4

IF IN DOUBT - ASK

©

NOT TO SCALE

THIRD ANGLE PROJECTION

ALL DIMENSIONS IN mm

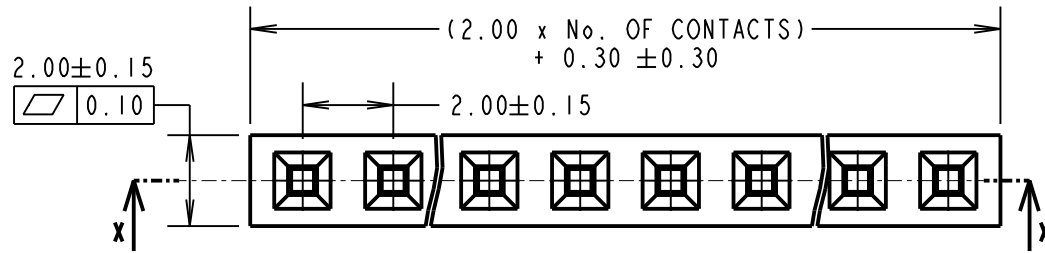

COMPONENT SPECIFICATIONS:

MATERIAL:

MOULD = GLASS FILLED LCP, UL94V-0
CONTACTS = PHOSPHOR BRONZE

FINISH:

0.76-2.03µ NICKEL ALL OVER,
0.015µ MIN GOLD ON CONTACT,
2.03-5.08µ TIN ON TAILS.

ELECTRICAL:

CURRENT RATING = 2A
CONTACT RESISTANCE = 20mΩ MAX
INSULATION RESISTANCE = 1000MΩ MIN
VOLTAGE PROOF = 500V AC FOR ONE MINUTE

MECHANICAL:

INSERTION FORCE = 1.96N MAX PER CONTACT
WITHDRAWAL FORCE = 0.19N MIN PER CONTACT
DURABILITY = 300 CYCLES MIN

ENVIRONMENTAL:

OPERATING TEMPERATURE = -40°C TO +105°C

PART SECTION X-X

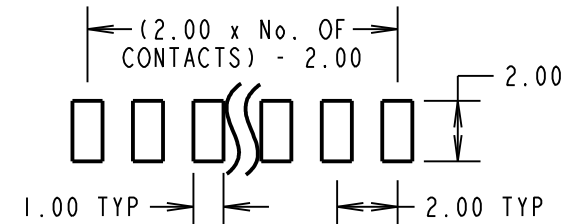
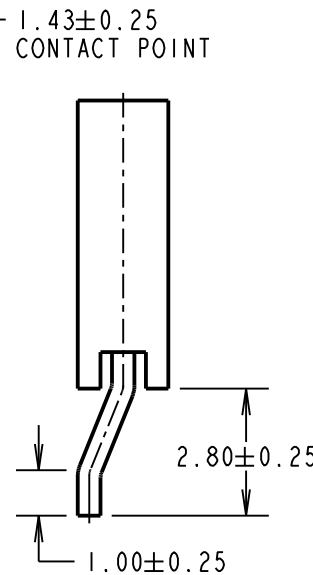
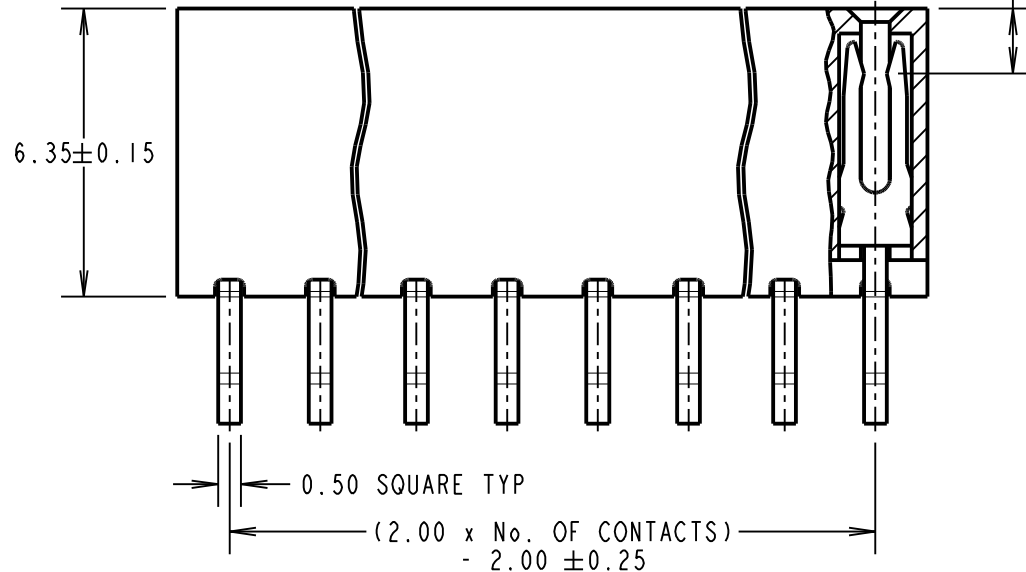

RECOMMENDED PCB LAYOUT
(TOLERANCE = ±0.05)

NOTES:
1. FOR TAPE AND REEL DETAILS, SEE SHEET 4.

ORDER CODE:

M22-654XX42R

No. OF CONTACTS PER ROW: _____
02-06, 08, 10

MSP	1	12.05.16	-----
NAME	ISS.	DATE	C/NOTE
APPROVED:		M.PERREN	
CHECKED:		S.BENNETT	
DRAWN:		M.PERREN	
CUSTOMER REF.:			
ASSEMBLY DRG:			

HARWIN

www.harwin.com
technical@harwin.com

THIS DRAWING AND ANY INFORMATION OR DESCRIPTIVE MATTER SET OUT HEREON ARE CONFIDENTIAL AND COPYRIGHT PROPERTY OF THE HARWIN GROUP AND MUST NOT BE DISCLOSED, LOANED, COPIED OR USED FOR MANUFACTURING, TENDERING OR FOR ANY OTHER PURPOSE WITHOUT THEIR WRITTEN PERMISSION.

TOLERANCES
X. = ±1mm
X.X = ±0.50mm
X.XX = ±0.10mm
X.XXX = ±0.01mm
ANGLES = ±5°
UNLESS STATED

MATERIAL:

SEE ABOVE

FINISH: SEE ABOVE

S/AREA: mm²

TITLE:

2.00mm PITCH SIL HORIZONTAL SOCKET, SMT TAPE & REEL

DRAWING NUMBER:

M22-654XX42R

SHT
3
OF
4

Customer Information Sheet

DRAWING No.: M22-654XX42R

SHEET 4 OF 4

IF IN DOUBT - ASK

©

NOT TO SCALE

THIRD ANGLE PROJECTION

ALL DIMENSIONS IN mm

TAPE DETAILS FOR
02, 03, 04, 05 & 06 WAY

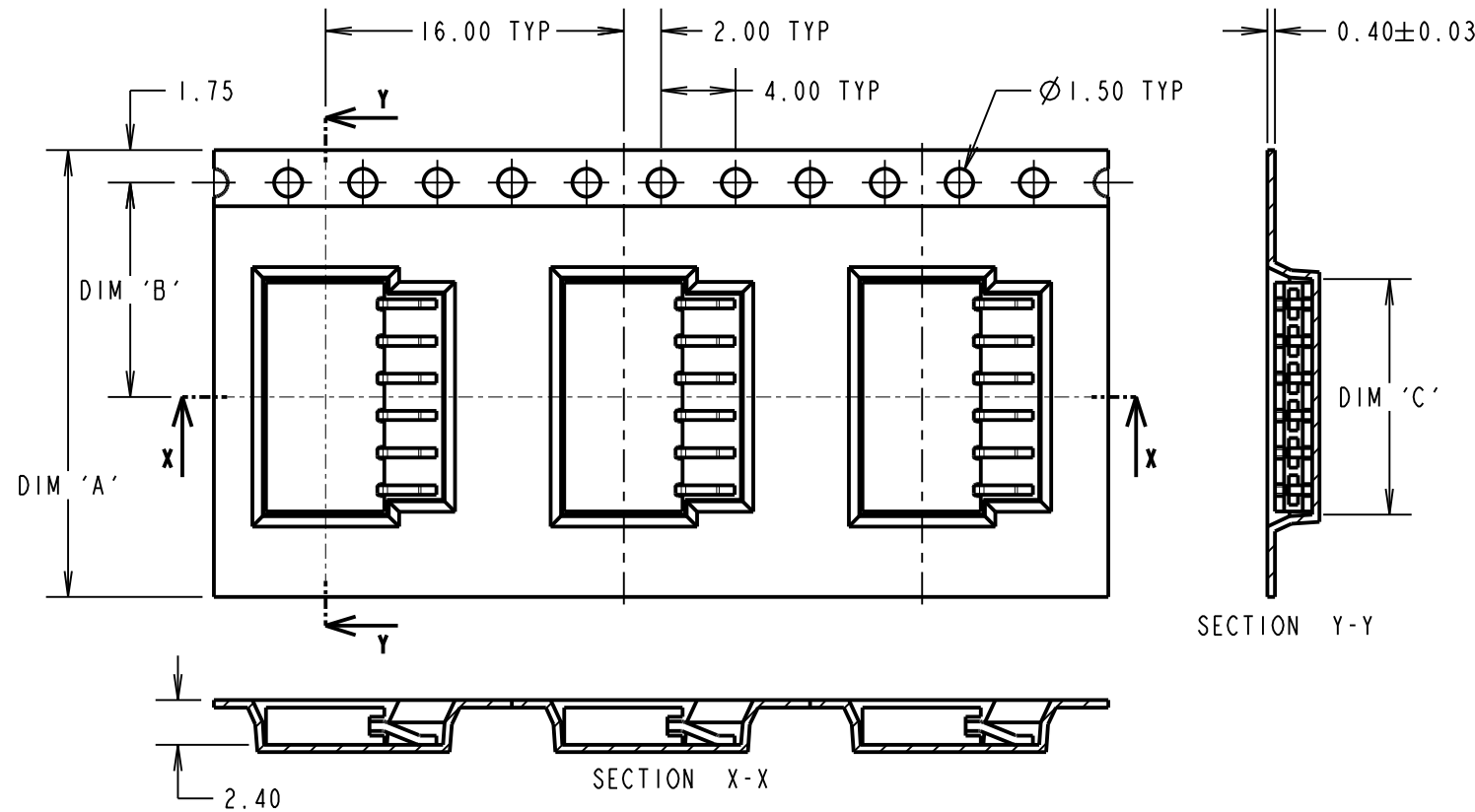

TAPE DETAILS FOR
08 & 10 WAY

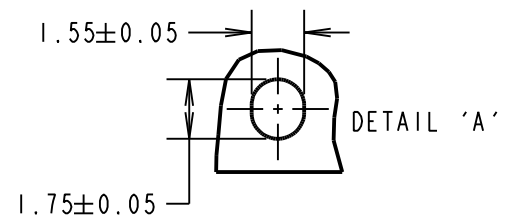
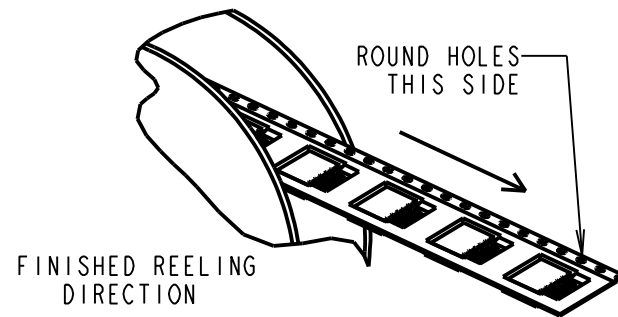
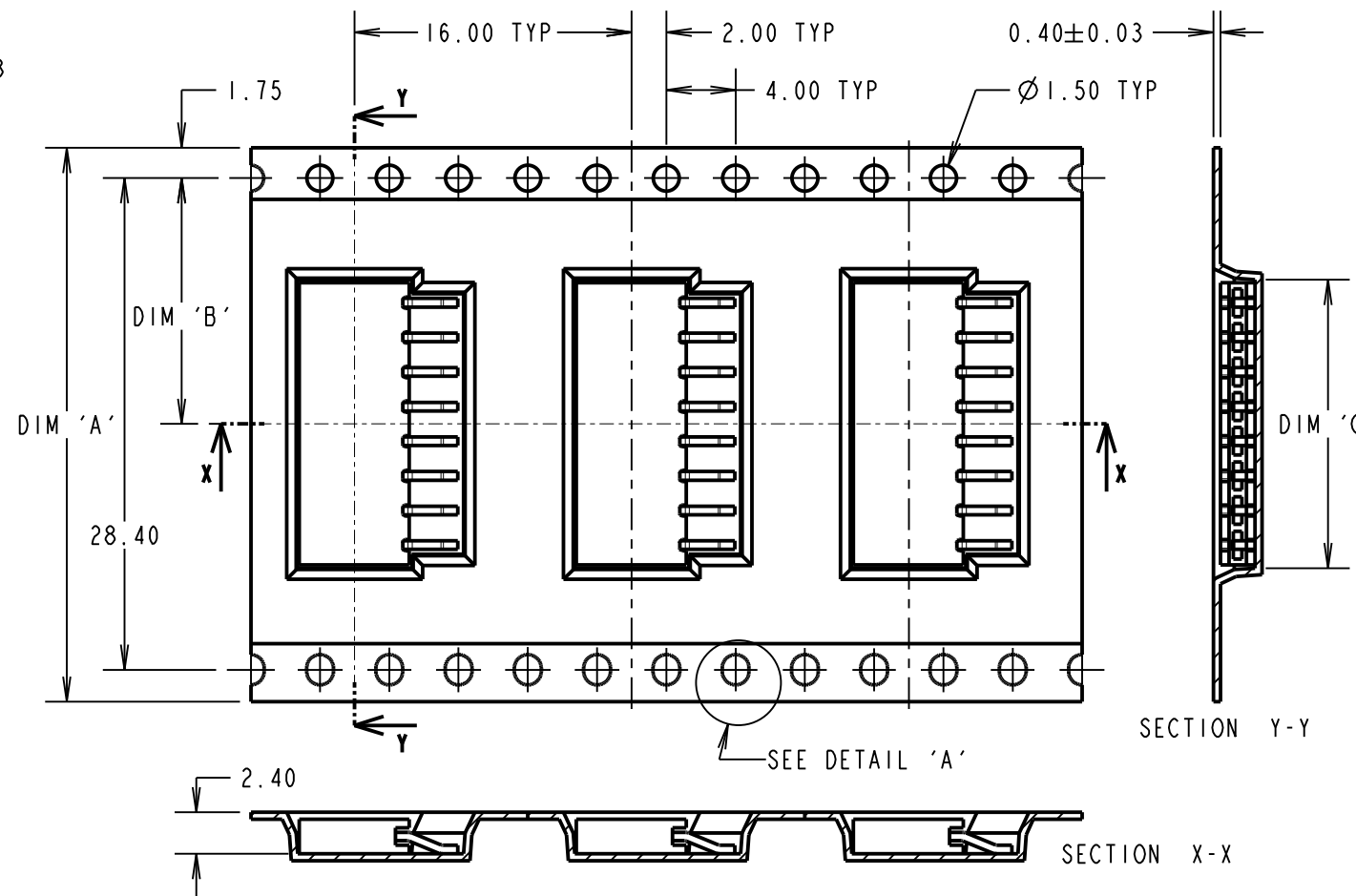

REEL DETAILS

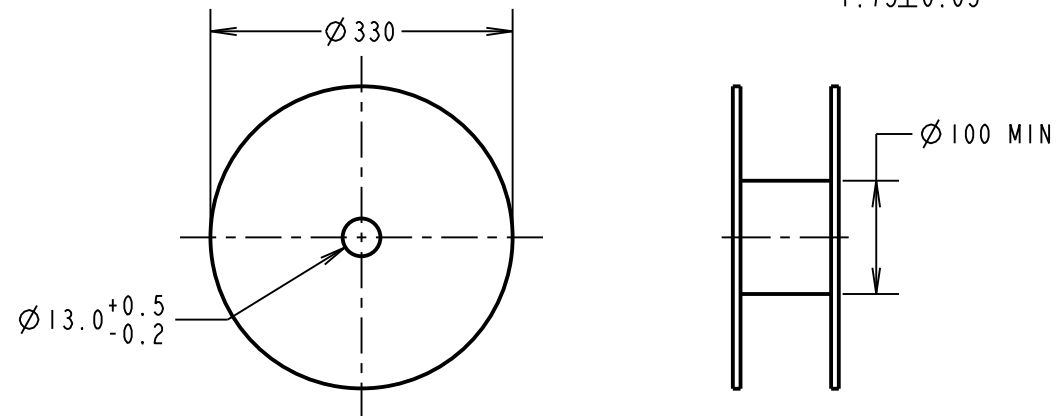

ORDER CODE: **M22-654XX42R**

No. OF CONTACTS PER ROW: _____
02-06, 08, 10

- NOTES:
1. PRODUCT IS TAPE AND REELED IN GENERAL ACCORDANCE WITH EIA-481 (ELECTRONIC INDUSTRIES ASSOCIATION).
 2. FOR CONNECTOR DETAILS AND SPECIFICATIONS, SEE SHEET 3.

PART No.	DIMENSION			REEL QUANTITY
	DIM 'A'	DIM 'B'	DIM 'C'	
M22-6540242R	16.00 ± 0.30	7.50 ± 0.15	4.65	1300
M22-6540342R	24.00	11.50	6.65	
M22-6540442R			8.65	
M22-6540542R			10.65	
M22-6540642R			12.65	
M22-6540842R			16.65	
M22-6541042R	32.00	14.20	20.65	

HARWIN

www.harwin.com
technical@harwin.com

THIS DRAWING AND ANY INFORMATION OR DESCRIPTIVE MATTER SET OUT HEREON ARE CONFIDENTIAL AND COPYRIGHT PROPERTY OF THE HARWIN GROUP AND MUST NOT BE DISCLOSED, LOANED, COPIED OR USED FOR MANUFACTURING, TENDERING OR FOR ANY OTHER PURPOSE WITHOUT THEIR WRITTEN PERMISSION.

TOLERANCES
X. = ±1mm
X.X = ±0.50mm
X.XX = ±0.10mm
X.XXX = ±0.01mm
ANGLES = ±5°
UNLESS STATED

MATERIAL:

SEE ABOVE

FINISH: SEE ABOVE

S/AREA:

mm²

TITLE:
2.00mm PITCH SIL HORIZONTAL SOCKET, SMT TAPE & REEL

DRAWING NUMBER:

M22-654XX42R

MSP	1	12.05.16	-----
NAME	ISS.	DATE	C/NOTE
APPROVED: M.PERREN			
CHECKED: S.BENNETT			
DRAWN: M.PERREN			
CUSTOMER REF.:			
ASSEMBLY DRG:			

SHT
4
OF
4