

- NOTES:
- ELECTRICAL:
    - CONTACT CURRENT RATING 5.0A FOR VBUS AND GND(PINS A4 A9 B4 B9)
    - INSULATION RESISTANCE: 100 MEGAOHMS MIN. AT 250VDC.
    - DIELECTRIC WITHSTANDING VOLTAGE: 100VAC MIN.
    - LOW CONTACT RESISTANCE: INITIAL 40mΩ MAX. AFTER 50mΩ MAX.
  - MECHANICAL CHARACTERISTICS:
    - INSERTION FORCE: 5N~20N.
    - EXTRACTION FORCE: 8N~20N FORM 1 TO 1000CYCLES. 6~20N FORM 1001 TO 10000CYCLES.
    - DURABILITY: 10,000 MATING CYCLES
    - OPERATING TEMPERATURE: -55°C TO +85°C
  - COPLANARITY: 0.10MAX.

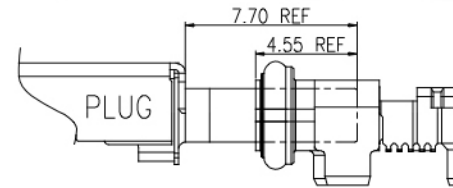
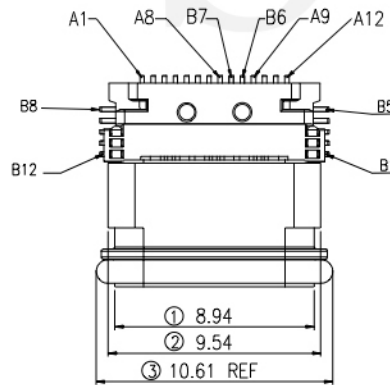
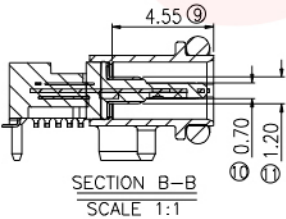

TABLE			
TEMPART NAME	QTY	MATERIAL	REMARK
1	SHELL	1PCS STAINLESS	NICKEL PLATED 50u" MIN. OVER ALL CLEAN
2	INSERT HOUSING	1PCS PA10T	UL94V-0
3	Mid-PLATE	1PCS STAINLESS	NI PLATED 50u" MIN. OVER ALL
4	TOP CONTACT	1SET COPPER ALLOY	NI UNDERPLATED 50 u" MIN OVER ALL; 1u" ON SOLDER TAIL;
5	BOTTOM CONTACT	1SET COPPER ALLOY	Gold Flash" or 5u" or 10u" or 15u" or 30u" ON CONTACT AREA.
6	RUBBER RING	1PCS SILICA GEL	MILKY WHITE



G-Switch Electronic Technology CO.,Ltd.

Unless otherwise specified, Tolerance:  
 X. ±0.30  
 X.x ±0.20  
 X.xx ±0.15  
 X.xxx ±0.10  
 Angles ±3°

DESIGN 陈锋枫 DATE 2016.05.29  
 CHECKED DATE  
 APPROVED DATE  
<http://www.dg-switch.com>  
 TEL:0769-82388879

TITLE: GT-USB-7018  
 REV.: X1 SCALE: 4:1 UNIT: mm  
 SIZE: A4 SHEET: 1/1

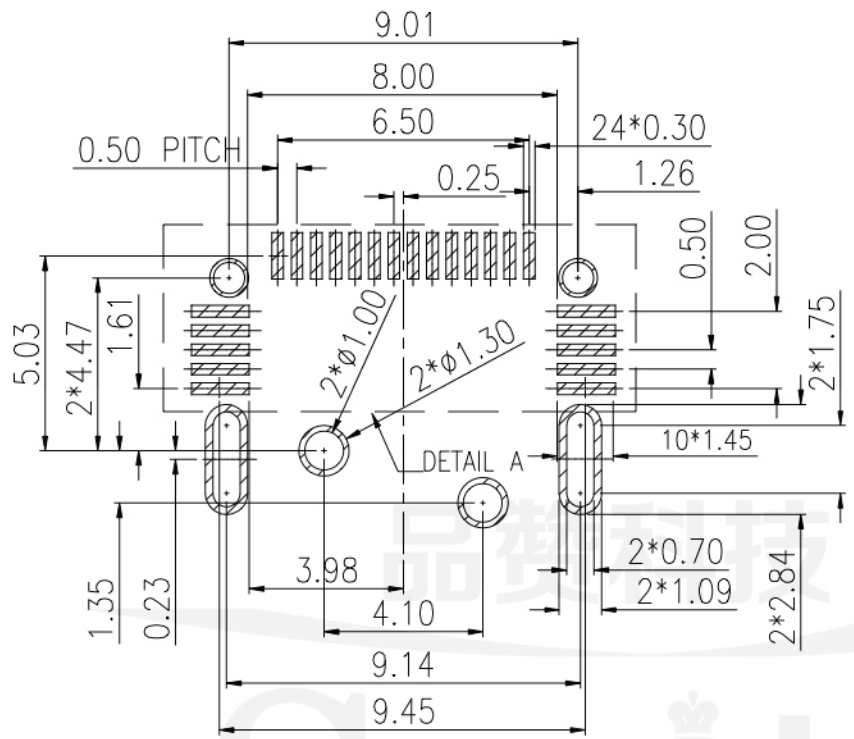

RECOMMENDED PCB LAYOUT  
TOLERANCE±0.05

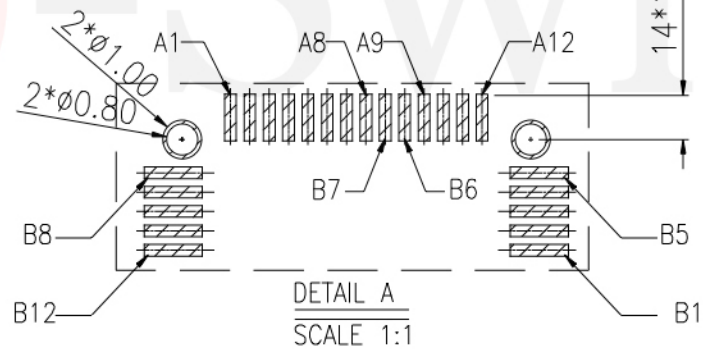

DETAIL A  
SCALE 1:1

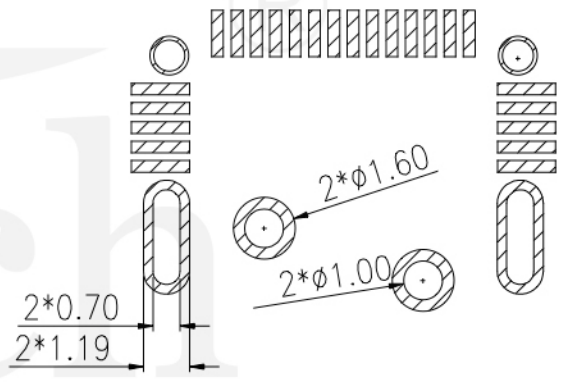

RECOMMENDED STENCIL LAYOUT  
TOLERANCE±0.05

PIN	SIGNAL NAME	PIN	SIGNAL NAME
A1	GND	B12	GND
A2	SSTXp1	B11	SSRXp1
A3	SSTXn1	B10	SSRXn1
A4	VBUS	B9	VBUS
A5	CC1	B8	SBU2
A6	Dp1	B7	Dn2
A7	Dn1	B6	Dp2
A8	SBU1	B5	CC2
A9	VBUS	B4	VBUS
A10	SSRXn2	B3	SSTXn2
A11	SSRXp2	B2	SSTXp2
A12	GND	B1	GND



G-Switch Electronic Technology CO.,Ltd.

Unless otherwise specified, Tolerance: X. ±0.30 X.x ±0.20 X.xx ±0.15 X.xxx ±0.10 Angles ±3°	DESIGN 陈锋枫 CHECKED APPROVED	DATE 2016.05.29 DATE DATE	TITLE: GT-USB-7018
<a href="http://www.dg-switch.com">http://www.dg-switch.com</a>	REV.: X1	SCALE: 4:1	UNIT: mm
TEL:0769-82388879	SIZE: A4	SHEET: 1/1	