



晶采光電科技股份有限公司
AMPIRE CO., LTD.

SPECIFICATIONS FOR LCD MODULE

CUSTOMER	
CUSTOMER PART NO.	
AMPIRE PART NO.	AO-12864TFIQW-00H-A(R)
APPROVED BY	
DATE	

- Approved For Specifications
 Approved For Specifications & Sample

AMPIRE CO., LTD.
TOWER A, 4F, No.114, Sec. 1, HSIN-TAI 5th RD., HIS-CHIH,
TAIPEI HSIEN, TAIWAN(R.O.C.)
台北縣汐止鎮新台五路一段114號4樓(東方科學園區A棟)
TEL:886-2-26967269, FAX:886-2-26967196 or 886-2-26967270

APPROVED BY	CHECKED BY	ORGANIZED BY

RECORD OF REVISION

Revision Date	Page	Contents	Editor
2007/5/3	--	New Release	Tony

1 FEATURES

- (1) Display format : 128×64 dots, 1/64 duty, 1/9 bias.
- (2) Construction : LCD panel , COG and FPC, White LED Back-light.
- (3) Display type : FSTN, Transflective, 6 o'clock view
- (4) Controller : ST7565
- (5) Extend temperature type.
- (6) ROHS compliant.

2 MECHANICAL DATA

Parameter	Stand Value	Unit
Dot size	0.355(W) × 0.355(H)	mm
Dot pitch	0.38(W) × 0.38(H)	mm
Active area	48.615(W) × 24.295 (H)	mm
Viewing area	52.6 (W) × 27.5 (H)	mm
Module size	59.0(W) × 65.4(H) × 7.2(T)	mm

3 ABSOLUTE MAXIMUM RATINGS

Parameter	Symbol	Min	Max	Unit
Logic Circuit Supply Voltage	VDD-VSS	-0.3	+7.0	V
LCD Driving Voltage	VLCD	-18.0	+0.3	V
Input Voltage	VI	-0.3	VDD+0.3	V
Operating Temp.	TOP	-20	70	°C
Storage Temp.	TSTG	-30	80	°C

4 ELECTRO-OPTICAL CHARACTERISTICS

Parameter	Symbol	Condition	Min	Typ	Max	Unit	Note
----- Electronic Characteristics -----							
Logic Circuit Supply Voltage	VDD-VSS	--	--	3.3	--	V	
LCD Driving Voltage (STN)	VLCD	-20 °C	10.2	11.2	12.2	V	
		25 °C	9.9	10.9	11.9		
		70 °C	9.6	10.6	11.6		
Input Voltage	VIH	--	0.8VDD	--	VDD	V	
	VIL	--	-0	--	0.2 VDD	V	
Logic Supply Current	IDD	VDD=3.3V	--	0.3	0.5	mA	
----- Optical Characteristics (FSTN) -----							
Contrast	CR	--	2	5			Note 1
Rise Time	tr	25°C	--	305	450	ms	Note 2
Fall Time	tf	25°C	--	120	180	ms	
Viewing Angle Range	θ f	25°C & CR≥2	--	40	--	Deg.	Note 3
	θ b		--	35	--		
	θ l		--	35	--		
	θ r		--	35	--		
Frame Frequency	fF	25°C	--	64	--	Hz	
----- White LED Back-light Characteristics -----							
Parameter	Symbol	Condition	Min	Typ	Max	Unit	Note
Forward Voltage	VF	IF=45mA	--	3.2	3.5	V	Supply Voltage between A&K Note 5
Forward Current	IF	--	--	45	60	mA	Note 4
LCM Luminous intensity		IF=45mA	--	18	--	cd/m ²	Note 4
LED C.I.E	X	IF=45mA	0.26	0.30	0.34		Note 6
	Y	IF=45mA	0.27	0.31	0.35		

(NOTE 4) Luminous intensity is decided from forward current of the White LED.

(NOTE 5) The Luminous Intensity depends on IF

(NOTE 6) White LEDs are with color tolerance

* LED Dice number = 3

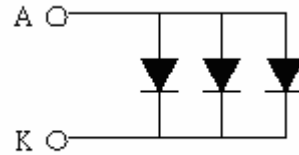

(NOTE 1) Contrast ratio :

$$CR = (\text{Brightness in OFF state}) / (\text{Brightness in ON state})$$

(NOTE 2) Response time :

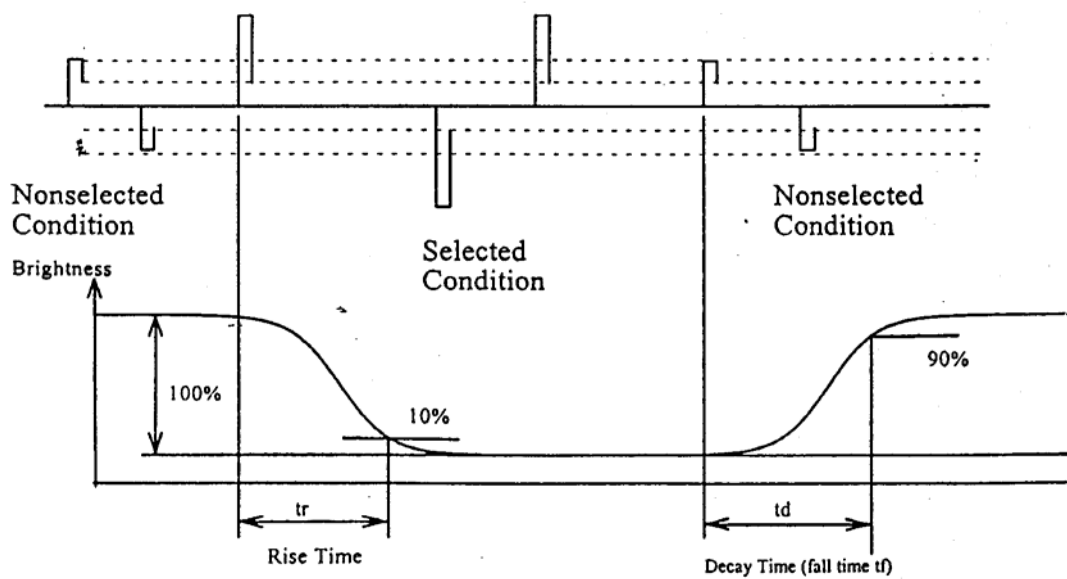

(NOTE 3) Viewing angle

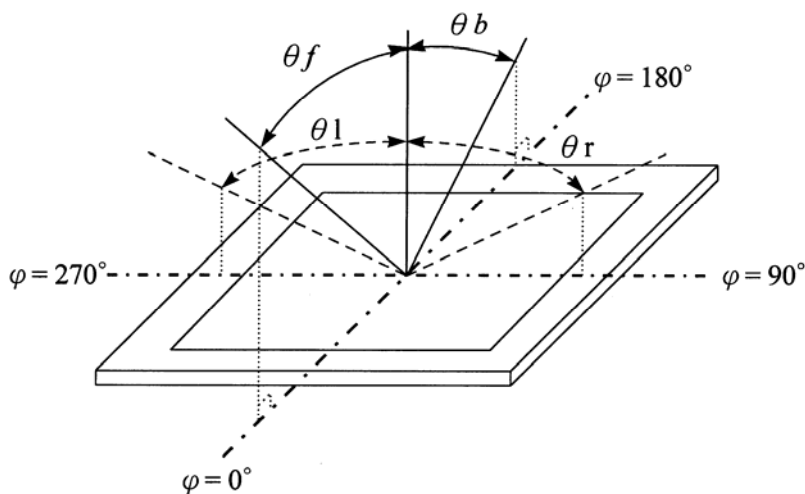

5 BLOCK DIAGRAM & POWER SUPPLY

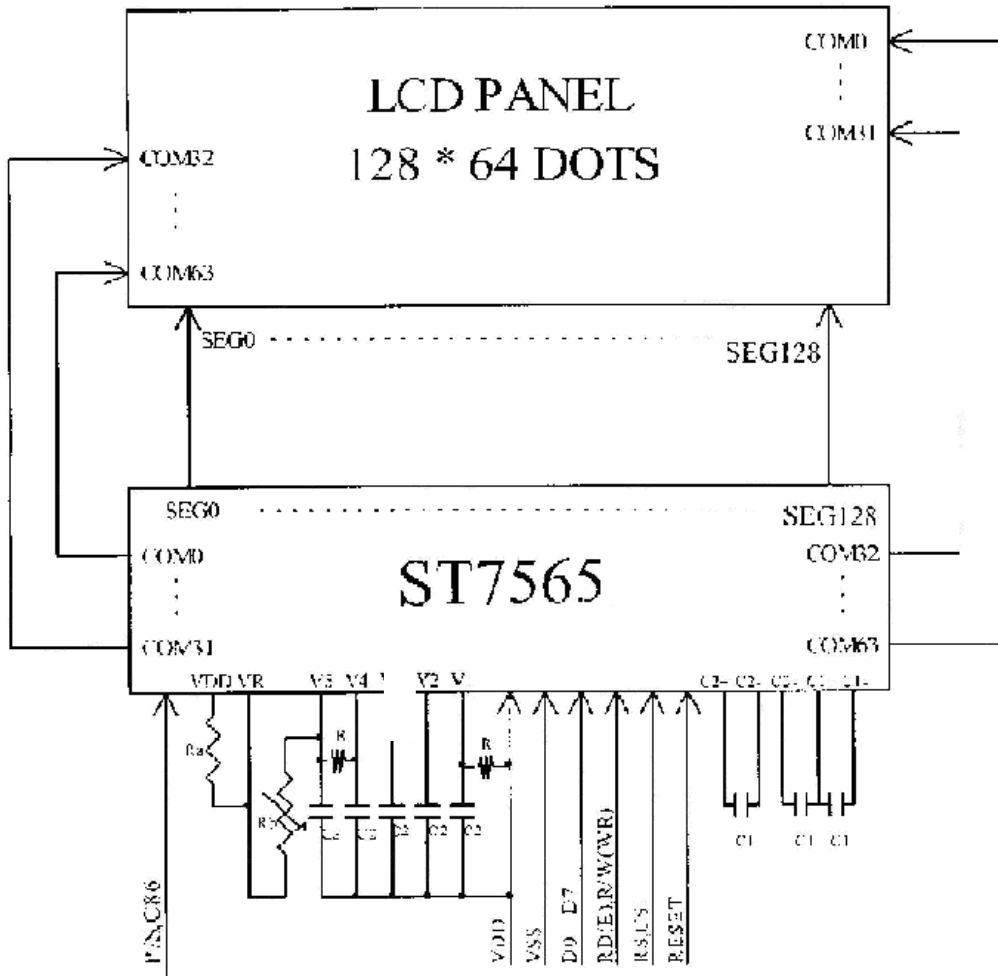

R : 100KΩ-150KΩ
 C1 : 1.0uf
 C2 : 0.1uf~0.47uf
 Ra , Rb : 1MΩ - 5MΩ

One LED

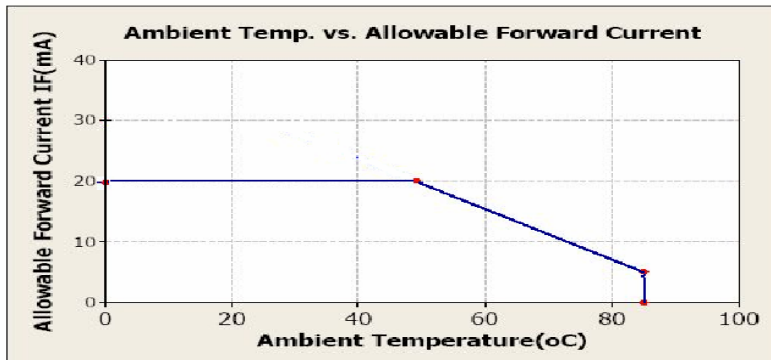

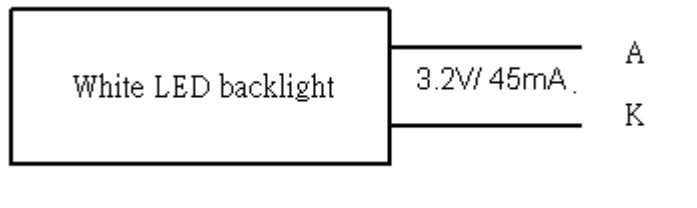

6 INTERFACE

No.	Symbol	Function	
1	P/S	Serial or interface selection terminal	
2	C86	MPU interface type selection terminal.	
3	VDD	Power supply for logic (VDD=+3v)	
4	VR	Voltage adjust terminal.	
5	V5	LCD driver supply voltage VDD (=V0) ≥ V1 ≥ V2 ≥ V3 ≥ V4 ≥ V5	
6	V4		
7	V3		
8	V2		
9	V1		
10	C2+	Used to voltage booster according to the boosting ratio.	
11	C2-		
12	C1-		
13	C1+		
14	C3-		
15	VOUT	Voltage converter output	
16	VSS	Ground (0V)	
17	VDD	Power supply for logic (VDD=+3v)	
18	D7	8-bit data bus	Serial input data (SDA)
19	D6		Serial input clock (SCK)
20	D5		When the serial interface selected (P/S="L"), DB0~DB5 : high impedance
21	D4		
22	D3		
23	D2		
24	D1		
25	D0		
26	RD(E)	68 Type : Enable signal of 68 type MPU input terminal. 80 Type : D0 to D7 terminals are output	
27	WR(R/W)	68 Type : read/write control signal of 68 type MPU input terminal. 80 Type : Data on the data bus input synchronizing the rise edge of this signal.	
28	A0	Connector to the address bus of MPU.	
29	RES	Reset terminal.	
30	CS1	Chip select terminal.	

.7 TIMING CHARACTERISTICS

8080-SYSTEM

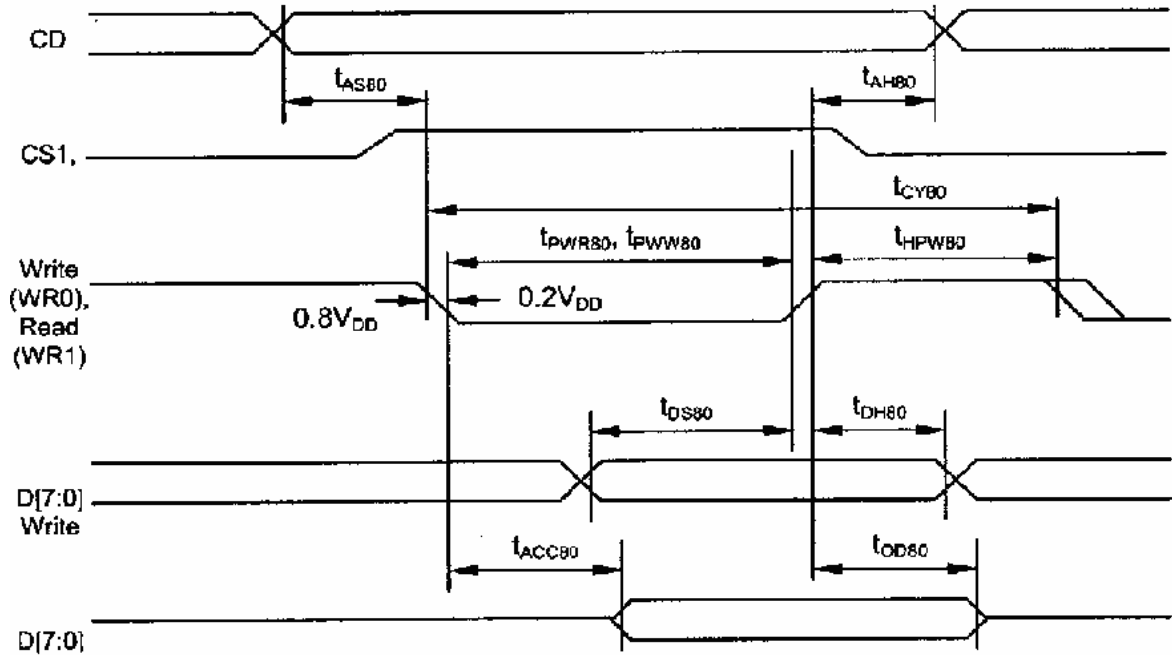

Parameter	Symbol	Min.	Typ.	Max.	Unit
<i>8080 Series(VDD=2.7~4.5V)</i>					
Address Hold Time(A0)	tAH8	0		-	ns
Address Setup Time(A0)	tAW8	0		-	ns
System Cycle Time((A0)	Tcyc8	300			ns
Control L Pulse Width(/WR)	tCCLW	60			ns
Control L Pulse Width(/RD)	tCCLR	120			ns
Control H Pulse Width(/WR)	tCCHW	60			ns
Control H Pulse Width(/RD)	tCCHR	60			ns
Data Setup Time(D0~7)	tDS8	40			ns
Address Hold Time	tDH8	15			ns
/RD access time	tACC8	-		140	ns
Output Disable Time	tOH8	10		100	ns

8. QUALITY AND RELIABILITY

8.1 TEST CONDITIONS

Tests should be conducted under the following conditions :

Ambient temperature : $25 \pm 5^{\circ}\text{C}$

Humidity : $60 \pm 25\% \text{ RH}$.

8.2 SAMPLING PLAN

Sampling method shall be in accordance with MIL-STD-105E , level II, normal single sampling plan .

8.3 ACCEPTABLE QUALITY LEVEL

A major defect is defined as one that could cause failure to or materially reduce the usability of the unit for its intended purpose. A minor defect is one that does not materially reduce the usability of the unit for its intended purpose or is an infringement from established standards and has no significant bearing on its effective use or operation.

8.4 APPEARANCE

An appearance test should be conducted by human sight at approximately 30 cm distance from the LCD module under fluorescent light. The inspection area of LCD panel shall be within the range of following limits.

9. INSPECTION QUALITY CRITERIA

Item	Description of defects			Class of Defects	Acceptable level (%)
Function	Short circuit or Pattern cut			Major	0.65
Dimension	Deviation from drawings			Major	1.5
Black spots	Ave . dia . D	area A	area B	Minor	2.5
	$D \leq 0.2$	Disregard			
	$0.2 < D \leq 0.3$	3	4		
	$0.3 < D \leq 0.4$	2	3		
	$0.4 < D$	0	1		
Black lines	Width W, Length L	A	B	Minor	2.5
	$W \leq 0.03$	disregard			
	$0.03 < W \leq 0.05$	3	4		
	$0.05 < W \leq 0.07, L \leq 3.0$	1	1		
	See line criteria				
Bubbles in polarizer	Average diameter D $0.2 < D < 0.5$ mm for N = 4 , D > 0.5 for N = 1			Minor	2.5
Color uniformity	Rainbow color or newton ring.			Minor	2.5
Glass Scratches	Obvious visible damage.			Minor	2.5
Contrast ratio	See note 1			Minor	2.5
Response time	See note 2			Minor	2.5
Viewing angle	See note 3			Minor	2.5

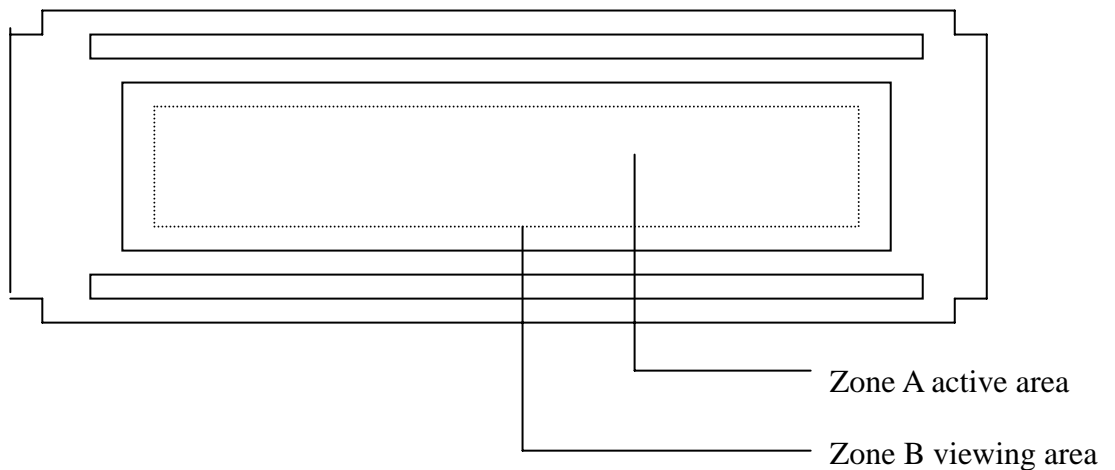

10 RELIABILITY

Test Item	Test Conditions	Note
	Extend Temp. type	
High Temperature Operation	70±3°C , t=96 hrs	
Low Temperature Operation	-20±3°C , t=96 hrs	
High Temperature Storage	80±3°C , t=96 hrs	1,2
Low Temperature Storage	-30±3°C , t=96 hrs	1,2
Thermal Shock Test	-30°C ~ 25°C ~ 80°C 30 m in. 5 min. 30 min. (1 cycle) Total 5 cycle	1,2
Humidity Test	40 °C, Humidity 90%, 96 hrs	1,2
Vibration Test (Packing)	Sweep frequency : 10 ~ 55 ~ 10 Hz/1min Amplitude : 0.75mm Test direction : X.Y.Z/3 axis Duration : 30min/each axis	2

Note 1 : Condensation of water is not permitted on the module.

Note 2 : The module should be inspected after 1 hour storage in normal conditions
(15-35°C , 45-65%RH).

Definitions of life end point :

- Current drain should be smaller than the specific value.
- Function of the module should be maintained.
- Appearance and display quality should not have degraded noticeably.
- Contrast ratio should be greater than 50% of the initial value.

11 HANDLING PRECAUTIONS

- (1) A LCD module is a fragile item and should not be subjected to strong mechanical shocks.
- (2) Avoid applying pressure to the module surface. This will distort the glass and cause a change in color.
- (3) Under no circumstances should the position of the bezel tabs or their shape be modified.
- (4) Do not modify the display PCB in either shape or positioning of components.
- (5) Do not modify or move location of the zebra or heat seal connectors.
- (6) The device should only be soldered to during interfacing. Modification to other areas of the board should not be carried out.
- (7) In the event of LCD breakage and resultant leakage of fluid do not inhale, ingest or make contact with the skin. If contact is made rinse immediately.
- (8) When cleaning the module use a soft damp cloth with a mild solvent, such as Isopropyl or Ethyl alcohol. The use of water, ketone or aromatic is not permitted.
- (9) Prior to initial power up input signals should not be applied.
- (10) Protect the module against static electricity and observe appropriate anti-static precautions.

12 OUTLINE DIMENSION

REV	REVISION RECORD	DATE	NAME
0	NEW RELEASE	02-09-04	MARK
1	RENAME 12864-91-1 to 12864T-QW	02-11-06	MARK

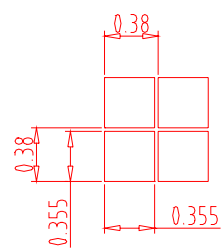
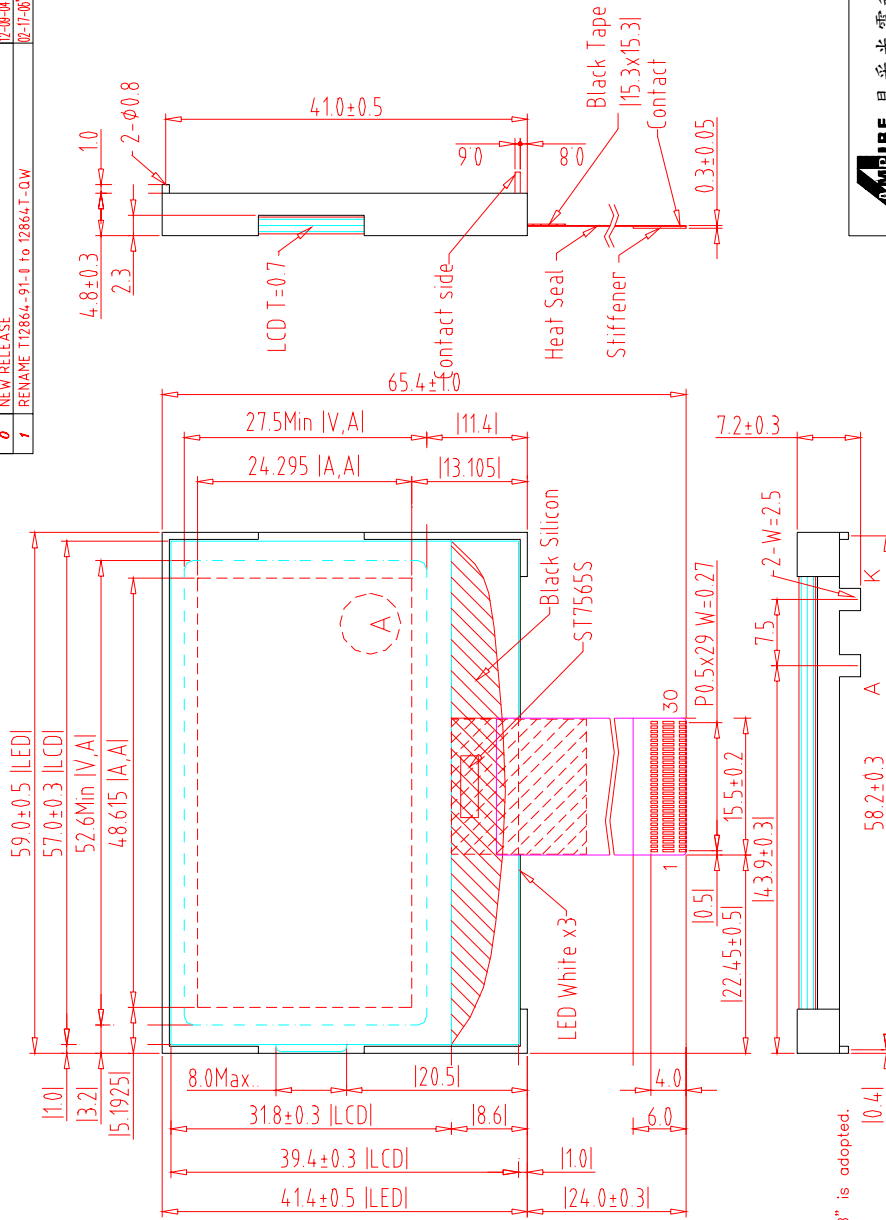

A Block	
1	P/S 16 VSS
2	C86 17 VDD
3	VDD 18 DB7
4	VR 19 DB6
5	V5 20 DB5
6	V4 21 DB4
7	V3 22 DB3
8	V2 23 DB2
9	V1 24 DB1
10	C2+ 25 DB0
11	C2- 26 RD(E)
12	C1- 27 WR(R/W)
13	C1+ 28 A0
14	C3- 29 RES
15	VOUT 30 CS1

Note:
 1. Unless indicated, Tolerance Grade "B" is adopted.
 2. RTV Glue For OLB Protection.

AMPIRE 晶采光電科技		TITLE	
1	LED White x3	DATE	12-09-04
2	12864-91-1	MARK	
3		CHK.	
4		DATE	
5		PARTS NO. LCM	12864T-QW
6		APPD.	
		DWG. NO.	*O41207MA
		SHEET 1 OF 1	