

Rad-hard 14-bit 30 Msps A/D converter

Datasheet – production data

Features

- Qml-V qualified, smd 5962-06260
- Rad hard: 300 kRad(Si) TID
- Failure immune (SEFI) and latch-up immune (SEL) up to 120 MeV-cm²/mg at 2.7 V and 125° C
- Hermetic package
- Tested at F_s = 20 Msps
- Low power: 85 mW at 20 Msps
- Optimized for 2 V_{pp} differential input
- High linearity and dynamic performances
- 2.5 V/3.3 V compatible digital I/O
- Internal reference voltage with external reference option

Applications

- Digital communication satellites
- Space data acquisition systems
- Aerospace instrumentation
- Nuclear and high-energy physics

Description

The RHF1401 is a 14-bit analog-to-digital converter that uses pure (ELDRS-free) CMOS 0.25 μm technology combining high performance, radiation robustness and very low power consumption.

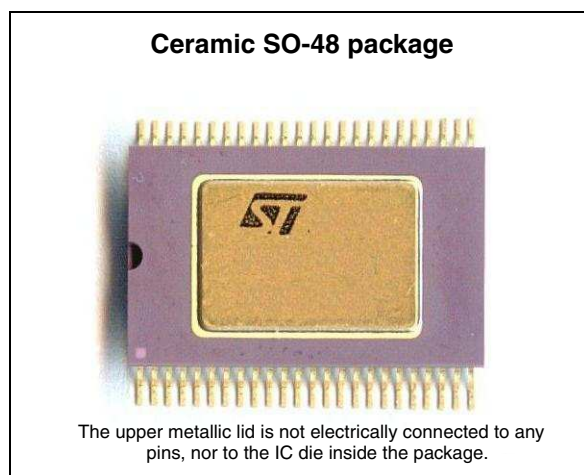

The RHF1401 is based on a pipeline structure and digital error correction to provide excellent static linearity. Specifically designed to optimize power consumption, the device only dissipates 85 mW at 20 Msps, while maintaining a high level of performance. The device also integrates a proprietary track-and-hold structure to ensure a large effective resolution bandwidth.

Voltage references are integrated in the circuit to simplify the design and minimize external components. A tri-state capability is available on the outputs to allow common bus sharing. A data-ready signal, which is raised when the data is valid on the output, can be used for synchronization purposes.

The RHF1401 has an operating temperature range of -55° C to +125° C and is available in a small 48-pin ceramic SO-48 package.

Table 1. Device summary

Order code	SMD pin	Quality level	Package	Lead finish	Mass	EPPL ⁽¹⁾	Temp range
RHF1401KSO1	-	Engineering model	SO-48	Gold	1.1 g	Yes	-55 °C to +125 °C
RHF1401KSO-01V	5962F0626001VXC	QMLV-Flight					

1. EPPL = ESA preferred part list

Contents

- 1 Description 7**
 - 1.1 Block diagram 7
 - 1.2 Pin connections 8
 - 1.3 Pin descriptions 9
 - 1.4 Equivalent circuits 10

- 2 Electrical characteristics 12**
 - 2.1 Absolute maximum ratings and operating conditions 12
 - 2.2 Timing characteristics 13
 - 2.3 Electrical characteristics (after 300 kRad) 14
 - 2.4 Results for differential input 16
 - 2.5 Results for single ended input 21

- 3 User manual 25**
 - 3.1 Optimizing the power consumption 25
 - 3.2 Driving the analog input 27
 - 3.2.1 Differential mode 27
 - 3.2.2 Single-ended mode 29
 - 3.3 Reference connections 31
 - 3.3.1 Internal voltage reference 31
 - 3.3.2 External voltage reference 31
 - 3.4 Clock input 33
 - 3.5 Operating modes 34
 - 3.5.1 Digital inputs 34
 - 3.5.2 Digital outputs 34
 - 3.5.3 Digital output load considerations 35
 - 3.6 PCB layout precautions 35

- 4 Definitions of specified parameters 36**
 - 4.1 Static parameters 36
 - 4.2 Dynamic parameters 36

- 5 Package information 37**

6	Ordering information	39
7	Revision history	40

List of tables

Table 1.	Device summary	1
Table 2.	Pin descriptions	9
Table 3.	Absolute maximum ratings	12
Table 4.	Operating conditions	12
Table 5.	Timing characteristics	13
Table 6.	Analog inputs	14
Table 7.	Internal reference voltage	14
Table 8.	External reference voltage	14
Table 9.	Static accuracy	14
Table 10.	Digital inputs and outputs	15
Table 11.	Dynamic characteristics	15
Table 12.	Differential mode output codes	27
Table 13.	Single-ended mode output codes with $V_{inb} = INCM$	29
Table 14.	RHF1401 operating modes	34
Table 15.	Ceramic SO-48 package mechanical data	38
Table 16.	Order codes	39
Table 17.	Document revision history	40

List of figures

Figure 1.	RHF1401 block diagram	7
Figure 2.	pin connections (top view)	8
Figure 3.	Analog inputs	10
Figure 4.	Output buffers	10
Figure 5.	Clock input	10
Figure 6.	Data format input	10
Figure 7.	Reference mode control input.	10
Figure 8.	Output enable input	10
Figure 9.	VREFP and INCM input/output.	11
Figure 10.	VREFM input	11
Figure 11.	Timing diagram	13
Figure 12.	Differential configuration	16
Figure 13.	ENOB vs. input frequency	17
Figure 14.	SINAD vs. input frequency	17
Figure 15.	THD vs. input frequency	17
Figure 16.	SNR vs. input frequency	17
Figure 17.	SFDR vs. input frequency	17
Figure 18.	Consumption vs. input frequency	17
Figure 19.	ENOB vs. sampling frequency	18
Figure 20.	SINAD vs. sampling frequency	18
Figure 21.	THD vs. sampling frequency	18
Figure 22.	SNR vs. sampling frequency	18
Figure 23.	SFDR vs. sampling frequency	18
Figure 24.	Power consumption vs. sampling frequency	18
Figure 25.	ENOB vs. VREFP	19
Figure 26.	SINAD vs. VREFP	19
Figure 27.	SNR vs. VREFP	19
Figure 28.	THD vs. VREFP	19
Figure 29.	ENOB vs. sine clock, diff. input.	19
Figure 30.	Clock threshold vs. temperature	19
Figure 31.	ENOB vs. temperature	20
Figure 32.	Power consumption vs. temp.	20
Figure 33.	DNL, differential input	20
Figure 34.	INL, differential input	20
Figure 35.	Single-ended input configuration	21
Figure 36.	ENOB vs. F_{in} , single-ended	22
Figure 37.	SINAD vs. F_{in} , single-ended	22
Figure 38.	THD vs. F_{in} , single-ended	22
Figure 39.	SNR vs. F_{in} , single-ended	22
Figure 40.	SFDR vs. F_{in} , single-ended	22
Figure 41.	Power consumption vs. F_{in}	22
Figure 42.	ENOB vs. V_{in} , F_{in} 1 kHz, V_{refp} = 0.8 V	23
Figure 43.	ENOB vs V_{in} , F_{in} = 2 MHz, V_{refp} = 0.8 V	23
Figure 44.	ENOB vs. V_{in} , F_{in} 1 kHz, V_{refp} = 1.0 V	23
Figure 45.	ENOB vs V_{in} , F_{in} = 2 MHz, V_{refp} = 1.0 V	23
Figure 46.	ENOB vs. V_{in} , F_{in} 1 kHz, V_{refp} = 1.2 V	23
Figure 47.	ENOB vs V_{in} , F_{in} = 2 MHz, V_{refp} = 1.2 V	23
Figure 48.	ENOB vs. V_{in} , F_{in} 1 kHz, V_{refp} = 1.4 V	24

Figure 49.	ENOB vs V_{in} , $F_{in} = 2$ MHz, $V_{refp} = 1.4$ V	24
Figure 50.	R_{pol} values vs. F_s	25
Figure 51.	Power consumption values vs. F_s with internal references disabled	26
Figure 52.	Equivalent $V_{IN} - V_{INB}$ (differential input)	27
Figure 53.	$2 V_{pp}$ differential input	28
Figure 54.	Differential implementation using a balun	28
Figure 55.	Optimized single-ended configuration (DC coupling), external REFP	29
Figure 56.	AC-coupling single-ended input configuration	30
Figure 57.	AC-coupling single-ended input configuration for low frequencies	30
Figure 58.	Internal voltage reference setting	31
Figure 59.	External voltage reference setting	32
Figure 60.	Example with zeners	32
Figure 61.	Clock input schematic	33
Figure 62.	Output buffer fall time	35
Figure 63.	Output buffer rise time	35
Figure 64.	Ceramic SO-48 package mechanical drawing	38

1 Description

1.1 Block diagram

Figure 1. RHF1401 block diagram

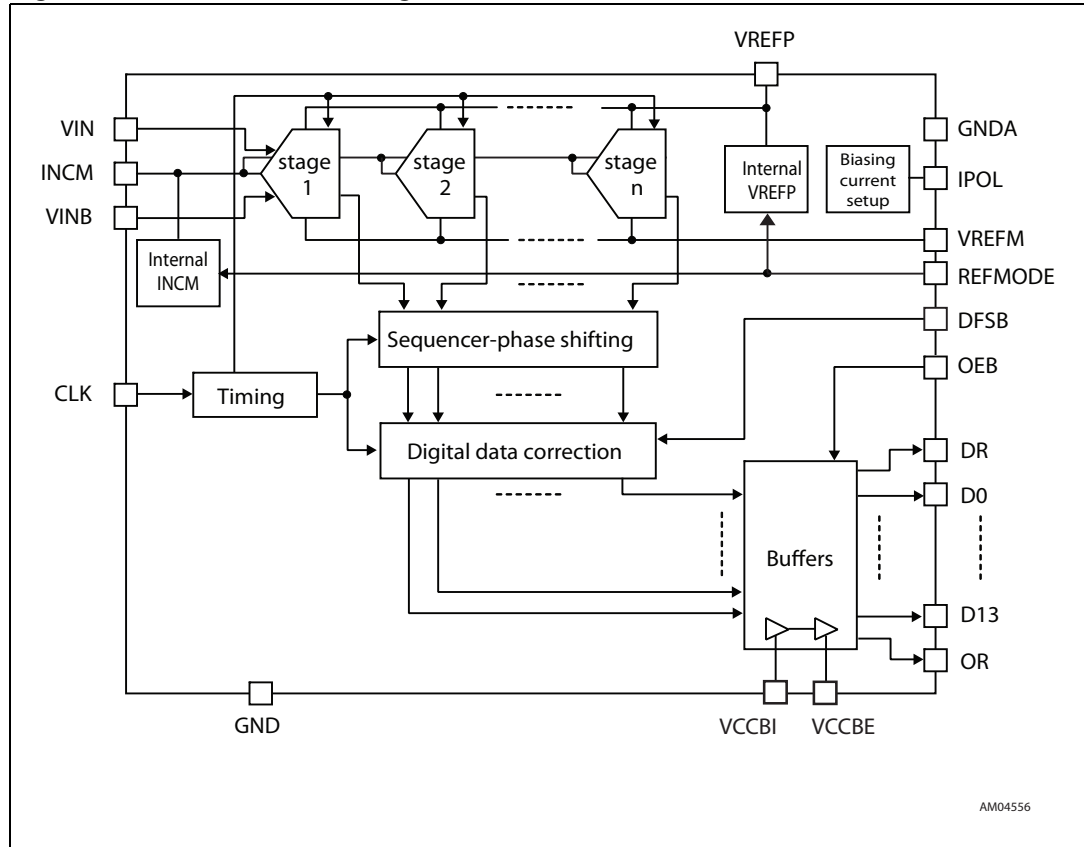

1.2 Pin connections

Figure 2. pin connections (top view)

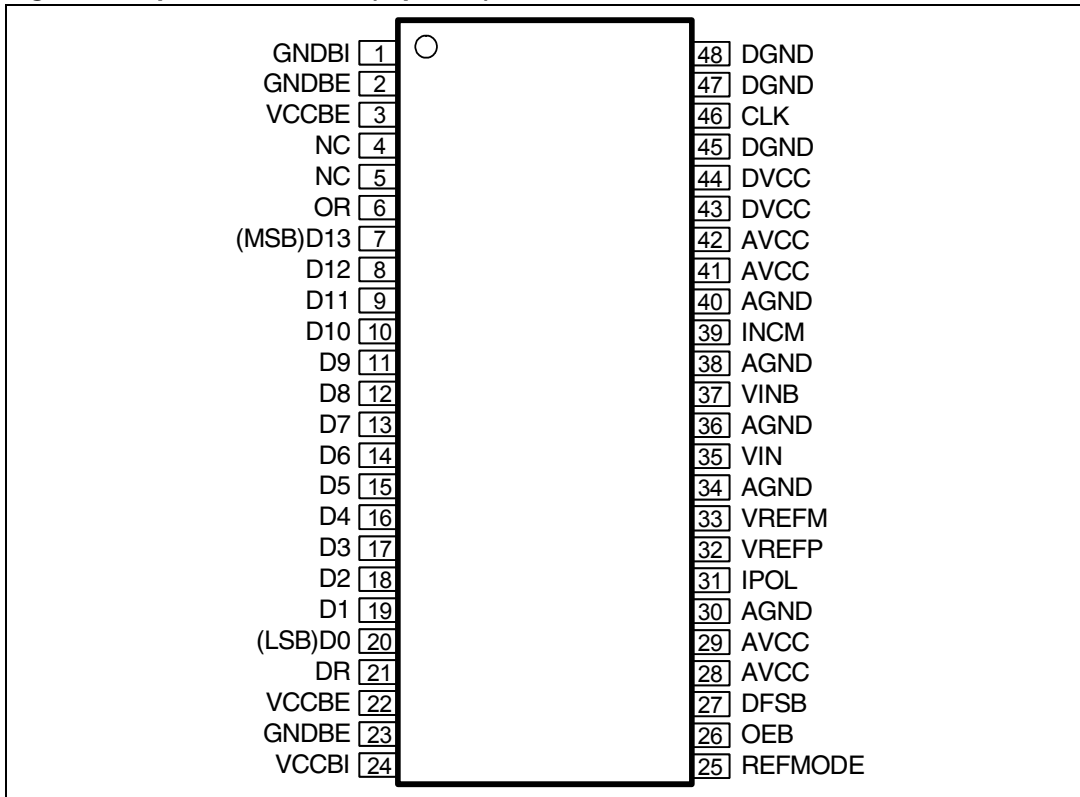

1.3 Pin descriptions

Table 2. Pin descriptions

Pin	Name	Description	Observations	Pin	Name	Description	Observations
1	GNDBI	Digital buffer ground	0 V	25	REFMODE	Ref. mode control input	2.5 V/3.3 V CMOS input
2	GNDBE	Digital buffer ground	0 V	26	OEB	Output enable input	2.5 V/3.3 V CMOS input
3	VCCBE	Digital buffer power supply	2.5 V/3.3 V	27	DFSB	Data format select input	2.5 V/3.3 V CMOS input
4		NC	Not connected to the dice	28	AVCC	Analog power supply	2.5 V
5		NC	Not connected to the dice	29	AVCC	Analog power supply	2.5 V
6	OR	Out of range output	CMOS output (2.5 V/3.3 V)	30	AGND	Analog ground	0 V
7	D13(MSB)	Most significant bit output	CMOS output (2.5 V/3.3 V)	31	IPOL	Analog bias current input	
8	D12	Digital output	CMOS output (2.5 V/3.3 V)	32	VREFP	Top voltage reference	Can be external or internal
9	D11	Digital output	CMOS output (2.5 V/3.3 V)	33	VREFM	Bottom voltage reference	0 V
10	D10	Digital output	CMOS output (2.5 V/3.3 V)	34	AGND	Analog ground	0 V
11	D9	Digital output	CMOS output (2.5 V/3.3 V)	35	VIN	Analog input	1 V _{pp}
12	D8	Digital output	CMOS output (2.5 V/3.3 V)	36	AGND	Analog ground	0 V
13	D7	Digital output	CMOS output (2.5 V/3.3 V)	37	VINB	Inverted analog input	1 V _{pp}
14	D6	Digital output	CMOS output (2.5 V/3.3 V)	38	AGND	Analog ground	0 V
15	D5	Digital output	CMOS output (2.5 V/3.3 V)	39	INCM	Input common mode	Can be external or internal
16	D4	Digital output	CMOS output (2.5 V/3.3 V)	40	AGND	Analog ground	0 V
17	D3	Digital output	CMOS output (2.5 V/3.3 V)	41	AVCC	Analog power supply	2.5 V
18	D2	Digital output	CMOS output (2.5 V/3.3 V)	42	AVCC	Analog power supply	2.5 V
19	D1	Digital output	CMOS output (2.5 V/3.3 V)	43	DVCC	Digital power supply	2.5 V
20	D0(LSB)	Digital output LSB	CMOS output (2.5 V/3.3 V)	44	DVCC	Digital power supply	2.5 V
21	DR	Data ready output ⁽¹⁾	CMOS output (2.5 V/3.3 V)	45	DGND	Digital ground	0 V
22	VCCBE	Digital buffer power supply	2.5 V/3.3 V	46	CLK	Clock input	2.5 V compatible CMOS input
23	GNDBE	Digital buffer ground	0 V	47	DGND	Digital ground	0 V
24	VCCBI	Digital buffer power supply	2.5 V	48	DGND	Digital ground	0 V

1. See load considerations in [Section 2.2: Timing characteristics](#).

1.4 Equivalent circuits

Figure 3. Analog inputs

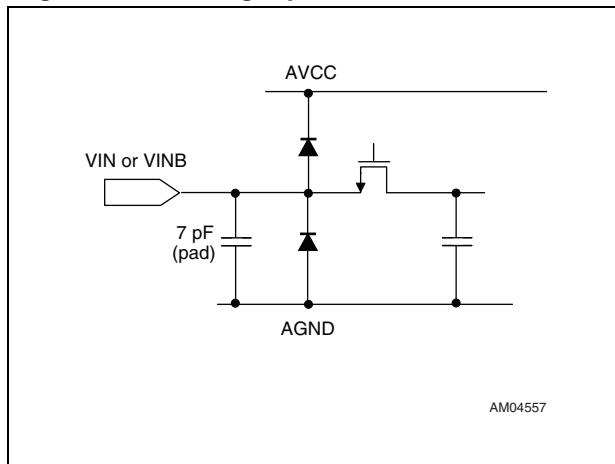

Figure 4. Output buffers

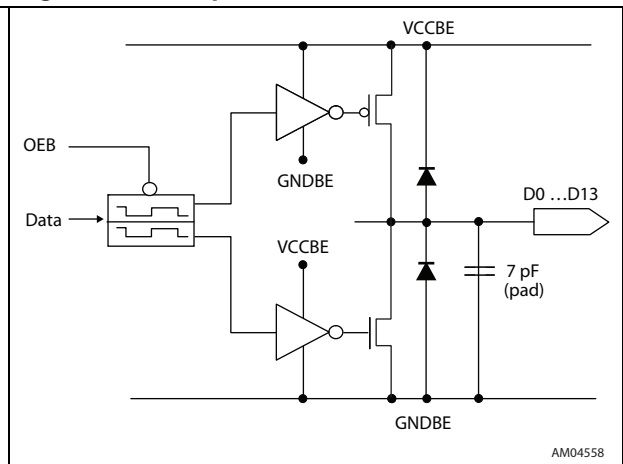

Figure 5. Clock input

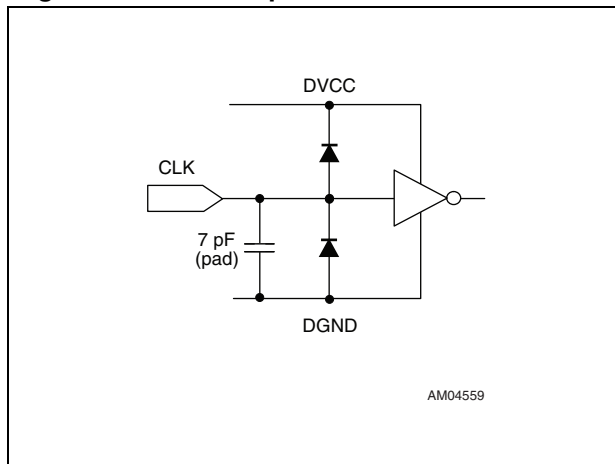

Figure 6. Data format input

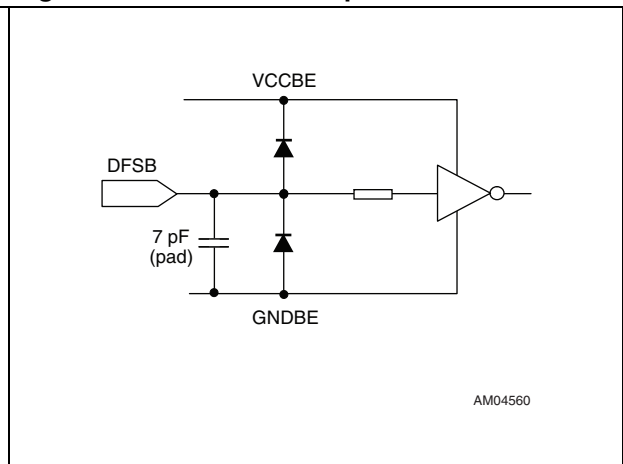

Figure 7. Reference mode control input

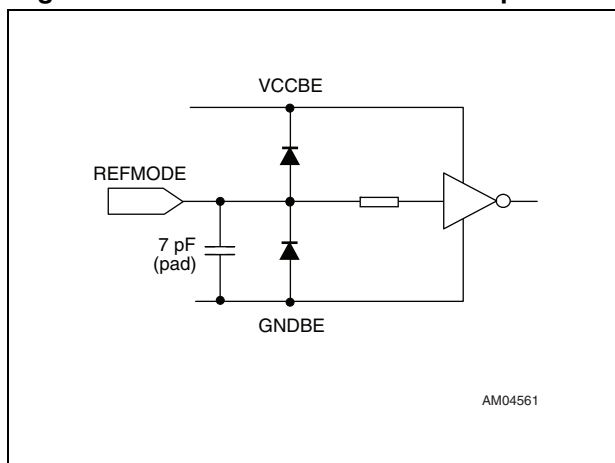

Figure 8. Output enable input

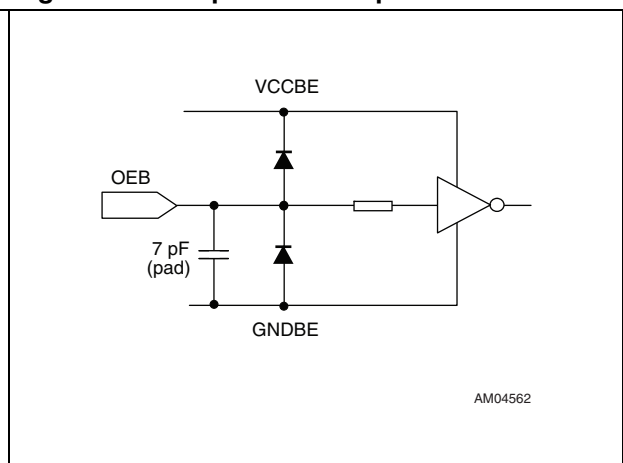

Figure 9. VREFP and INCM input/output

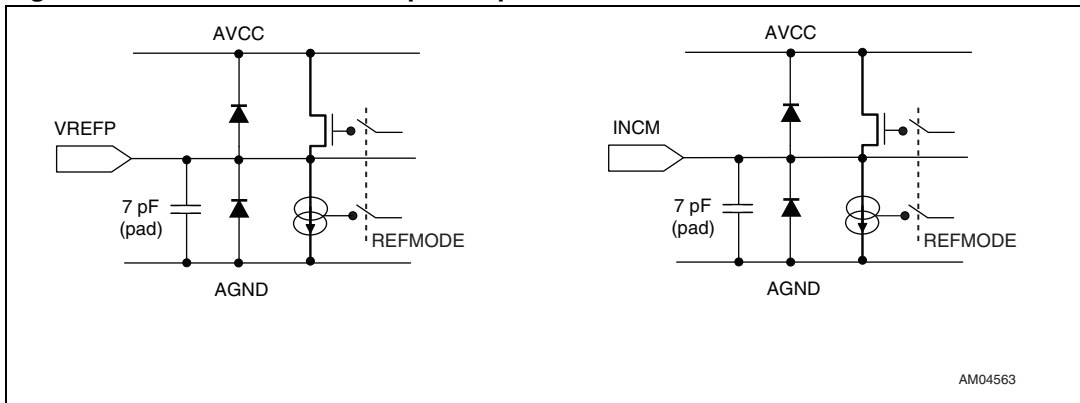
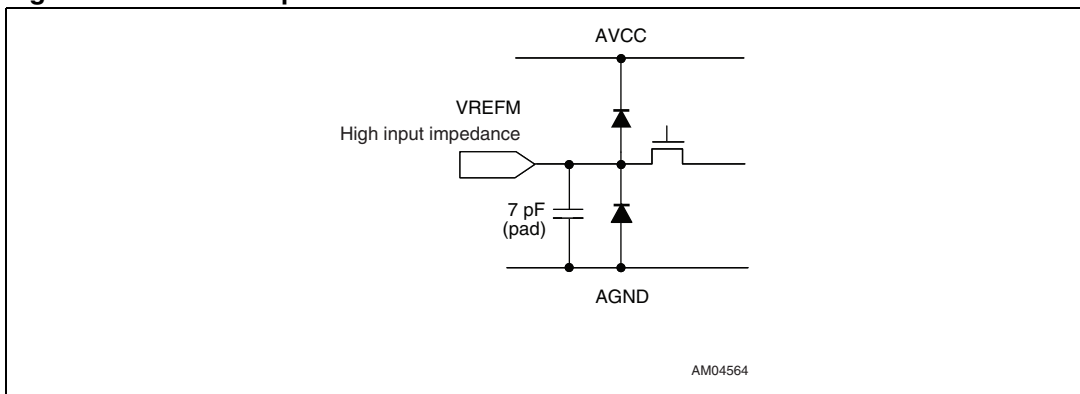

Figure 10. VREFM input



2 Electrical characteristics

2.1 Absolute maximum ratings and operating conditions

Table 3. Absolute maximum ratings

Symbol	Parameter	Values	Unit
AV_{CC}	Analog supply voltage	3.3	V
DV_{CC}	Digital supply voltage	3.3	V
V_{CCBI}	Digital buffer supply voltage	3.3	V
V_{CCBE}	Digital buffer supply voltage	3.6	V
V_{IN} V_{INB}	Analog inputs: bottom limit \rightarrow top limit	-0.6 V \rightarrow $AV_{CC}+0.6$ V	V
V_{REFP} V_{INCM}	External references: bottom limit \rightarrow top limit	-0.6 V \rightarrow $AV_{CC}+0.6$ V	V
I_{Dout}	Digital output current	-100 to 100	mA
T_{stg}	Storage temperature	-65 to +150	$^{\circ}$ C
R_{thjc}	Thermal resistance junction to case	22	$^{\circ}$ C/W
R_{thja}	Thermal resistance junction to ambient	125	$^{\circ}$ C/W
ESD	HBM (human body model) ⁽¹⁾	2	kV

1. Human body model: a 100 pF capacitor is charged to the specified voltage, then discharged through a 1.5 k Ω resistor between two pins of the device. This is done for all couples of connected pin combinations while the other pins are floating.

Table 4. Operating conditions

Symbol	Parameter	Min	Typ	Max	Unit
AV_{CC}	Analog supply voltage	2.3	2.5	2.7	V
DV_{CC}	Digital supply voltage	2.3	2.5	2.7	V
V_{CCBI}	Digital internal buffer supply	2.3	2.5	2.7	V
V_{CCBE}	Digital output buffer supply	2.3	2.5	3.4	V
V_{REFP}	Forced top voltage reference	0.7	1	1.4	V
V_{REFM}	Bottom external reference voltage	0	0	0.5	V
V_{INCM}	Forced common mode voltage	0.2	0.5	1.1	V
V_{IN} or V_{INB}	Max. voltage versus GND		1	1.6 ⁽¹⁾	V
	Min. voltage versus GND	-0.2	GND		V
DFSB	Digital inputs	0		V_{CCBE}	V
REFMODE					
OEB					

1. See [Figure 25](#). for differential input and [Figure 42](#). to [Figure 49](#). for single-ended.

2.2 Timing characteristics

Table 5. Timing characteristics

Symbol	Parameter	Test conditions	Min	Typ	Max	Unit
DC	Clock duty cycle	$F_s = 20$ Msps	45	50	65	%
T_{od}	Data output delay (fall of clock to data valid) ⁽¹⁾	10 pF load capacitance	5	7.5	13	ns
T_{pd}	Data pipeline delay ⁽²⁾	Duty cycle = 50%	7.5	7.5	7.5	cycles
T_{on}	Falling edge of OEB to digital output valid data			1		ns
T_{off}	Rising edge of OEB to digital output tri-state			1		ns
T_{rD}	Data rising time	10 pF load capacitance		6		ns
T_{fD}	Data falling time	10 pF load capacitance		3		ns

- As per [Figure 11](#).
- If the duty cycle does not equal 50%: $T_{pd} = 7$ cycles + CLK pulse width.

Figure 11. Timing diagram

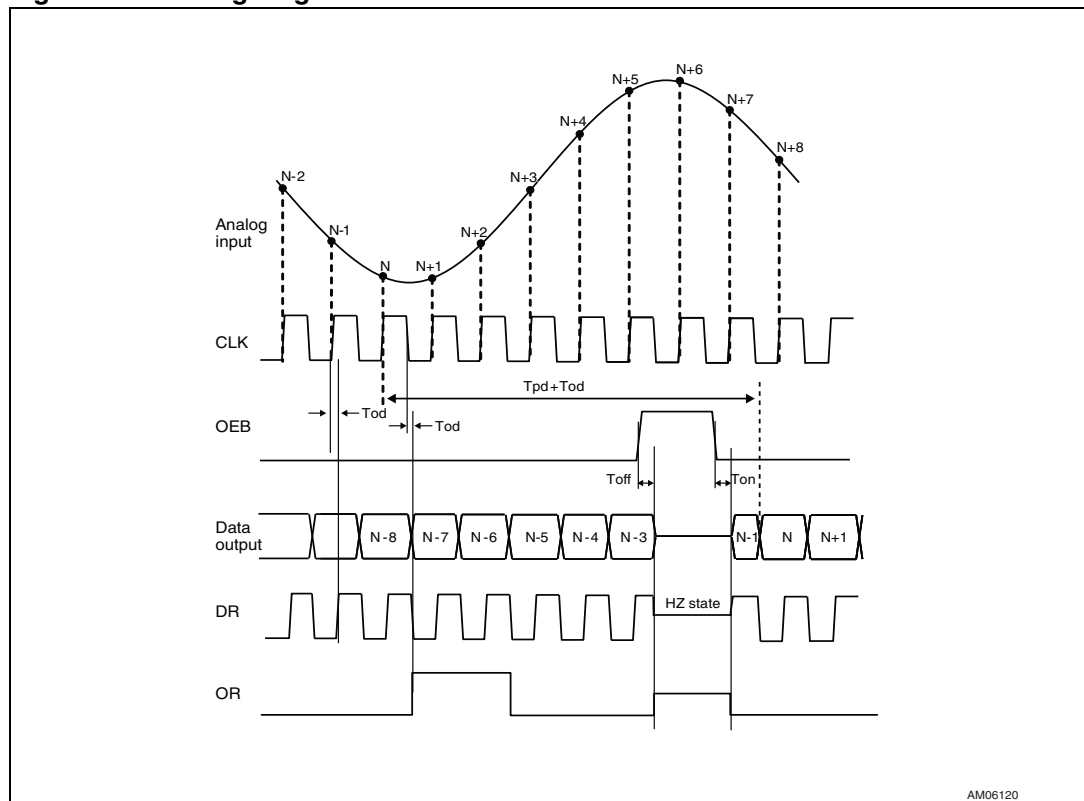

The input signal is sampled on the rising edge of the clock while the digital outputs are synchronized on the falling edge of the clock. The duty cycles on DR and CLK are the same.

The rising and falling edges of the OR pin are synchronized with the falling edge of the DR pin.

2.3 Electrical characteristics (after 300 kRad)

Unless otherwise specified, the test conditions in the following tables are:
 AVCC = DVCC = VCCBI = VCCBE = 2.5 V, F_S = 20 Msps, F_{IN} = 15 MHz, V_{IN} at -1 dBFS,
 VREFP = 1 V, INCM = 0.5 V, VREFM = 0 V, T_{amb} = 25 °C.

Table 6. Analog inputs

Symbol	Parameter	Test conditions	Min	Typ	Max	Unit
V _{IN} -V _{INB}	Full-scale reference voltage (FS) ⁽¹⁾	VREFP = 1 V (forced) VREFM = 0 V		2		V _{pp}
C _{IN}	Input capacitance			7		pF
Z _{IN}	Input impedance	F _S = 20 Msps		3.3		kΩ
ERB	Effective resolution bandwidth ⁽¹⁾			70		MHz

1. See [Section 4: Definitions of specified parameters](#) for more information.

Table 7. Internal reference voltage

Symbol	Parameter	Test conditions	Min	Typ	Max	Unit
R _{out}	Output resistance of internal reference	REFMODE = 0 internal reference on		30		Ω
		REFMODE = 1 internal reference off		7.5		kΩ
V _{REFP}	Top internal reference voltage	REFMODE = 0	0.76	0.84	0.95	V
V _{INCM}	Input common mode voltage	REFMODE = 0	0.40	0.44	0.50	V

Table 8. External reference voltage⁽¹⁾

Symbol	Parameter	Test conditions	Min	Typ	Max	Unit
V _{REFP}	Forced top reference voltage	REFMODE = 1	0.7		1.4	V
V _{REFM}	Forced bottom ref voltage	REFMODE = 1	0		0.5	V
V _{INCM}	Forced common mode voltage	REFMODE = 1	0.2		1.1	V

1. See [Figure 59](#) & [Figure 60](#)

Table 9. Static accuracy

Symbol	Parameter	Test conditions	Min	Typ	Max	Unit
DNL	Differential non-linearity ⁽¹⁾	F _{in} = 1.5 Msps V _{in} at +1 dBFS F _S = 1.5 Msps		±0.4		LSB
INL	Integral non-linearity ⁽²⁾			±3		LSB
	Monotonicity and no missing codes		Guaranteed			

1. See [Figure 33](#) and [Section 4](#) for more information. This parameter is not tested.

2. See [Figure 34](#) and [Section 4](#) for more information. This parameter is not tested.

Table 10. Digital inputs and outputs

Symbol	Parameter	Test conditions	Min	Typ	Max	Unit
Clock input						
CT	Clock threshold	$DV_{CC} = 2.5\text{ V}$		1.25		V
CA	Square clock amplitude (DC component = 1.25 V)	$DV_{CC} = 2.5\text{ V}$	0.8		2.5	V _{pp}
Digital inputs						
V_{IL}	Logic "0" voltage	$V_{CCBE} = 2.5\text{ V}$	0		$0.25 \times V_{CCBE}$	V
V_{IH}	Logic "1" voltage	$V_{CCBE} = 2.5\text{ V}$	$0.75 \times V_{CCBE}$		V_{CCBE}	V
Digital outputs						
V_{OL}	Logic "0" voltage	$I_{OL} = -10\ \mu\text{A}$		0	0.25	V
V_{OH}	Logic "1" voltage	$I_{OH} = 10\ \mu\text{A}$	$V_{CCBE} - 0.25$			V
I_{OZ}	High impedance leakage current	OEB set to V_{IH}	-15		15	μA
C_L	Output load capacitance	High CLK frequencies			15	pF

Table 11. Dynamic characteristics

Symbol	Parameter	Test conditions	Min	Typ	Max	Unit
SFDR	Spurious free dynamic range	$F_{in} = 15\text{ MHz}$ $F_s = 20\text{ Msps}$ V_{in} at -1 dBFS internal references $C_L = 6\text{ pF}$	70	91		dBFS
SNR	Signal to noise ratio		66	70		dB
THD	Total harmonic distortion		70	86		dB
SINAD	Signal to noise and distortion ratio		65	70		dB
ENOB	Effective number of bits		10.6	11.5		bits

Higher values of SNR, SINAD and ENOB can be obtained by increasing the full-scale range of the analog input if the sampling frequency allows it.

2.4 Results for differential input

Setup

- AVCC = DVCC = VCCBI = VCCBE = 2.5V
- VREFP = 1 V
- VREFM = 0 V
- INCM = VREFP/2
- REFMODE = 1 (internal references are disabled)
- Vin = full scale - 0.3 dB
- Tamb = 25C°
- A square clock is applied

Unless other test conditions are specified.

Figure 12. Differential configuration

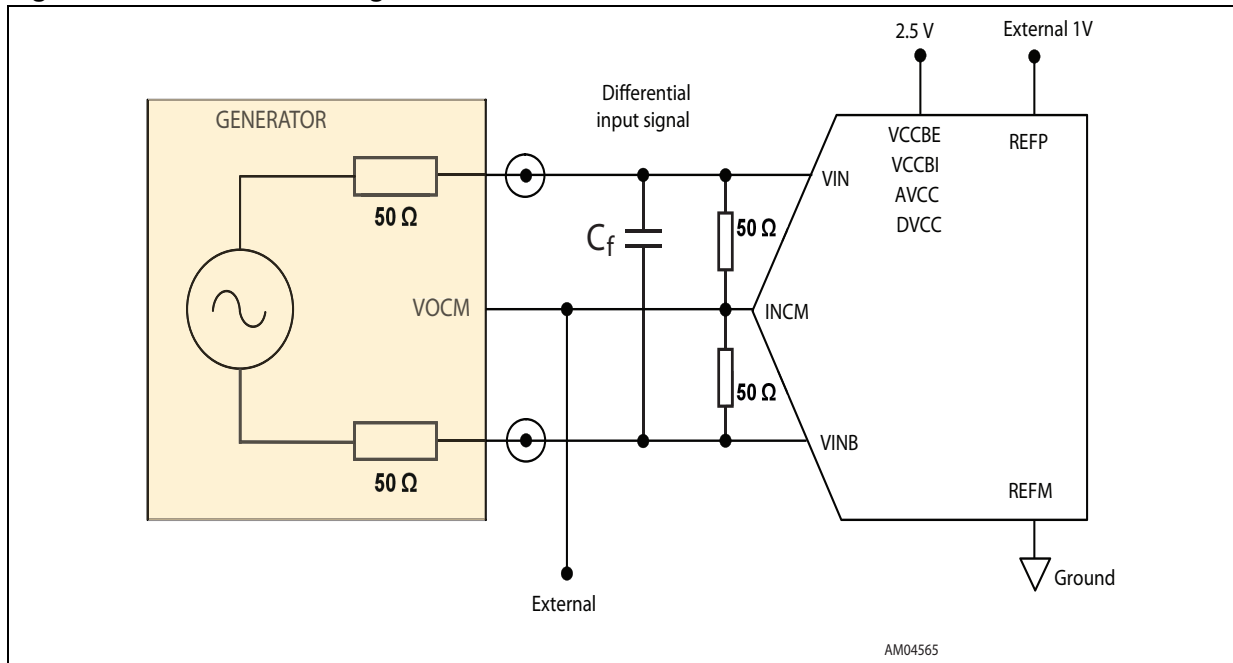

C_f is a filter capacitor to cut the HF noise. Its value is 10 nF for input frequencies equal to or below 20 kHz. The value of the capacitor is divided by two when the input frequency is multiplied by 2.

Figure 13. ENOB vs. input frequency

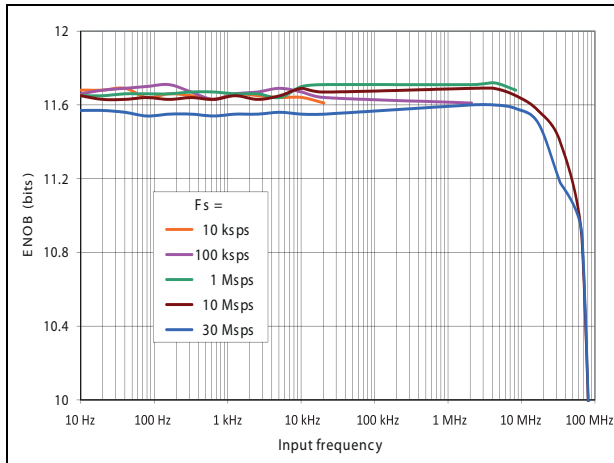

Figure 14. SINAD vs. input frequency

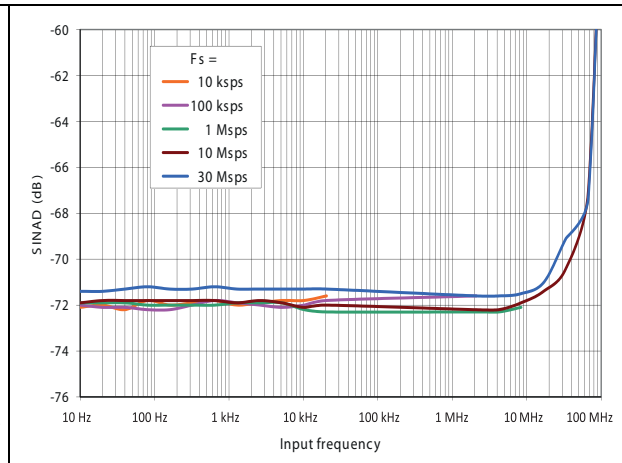

Figure 15. THD vs. input frequency

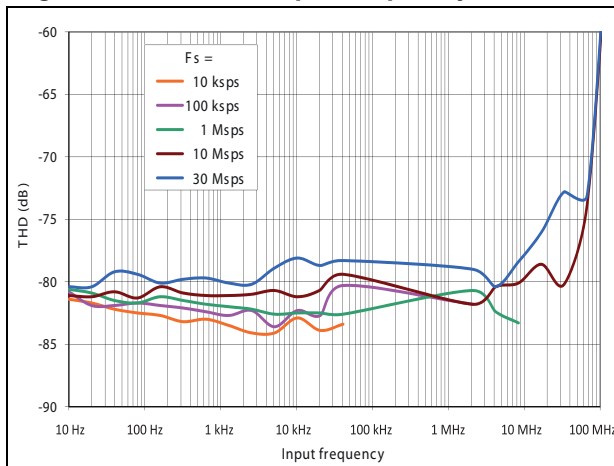

Figure 16. SNR vs. input frequency

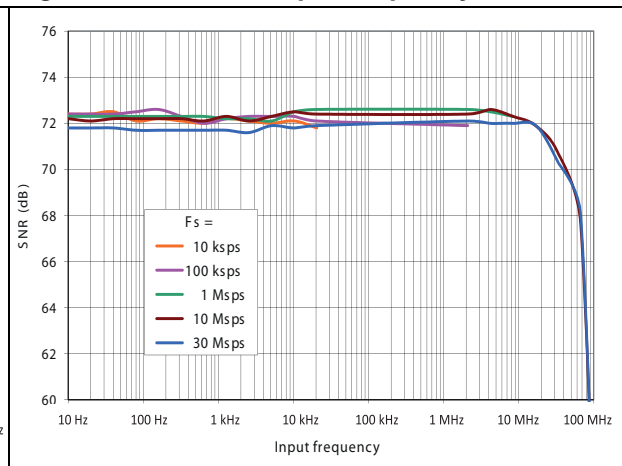

Figure 17. SFDR vs. input frequency

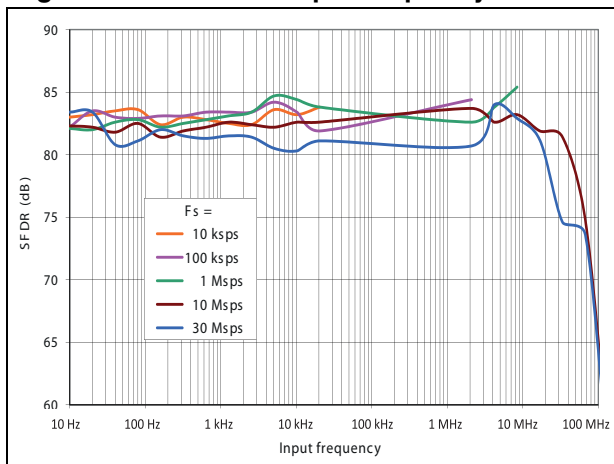

Figure 18. Consumption vs. input frequency

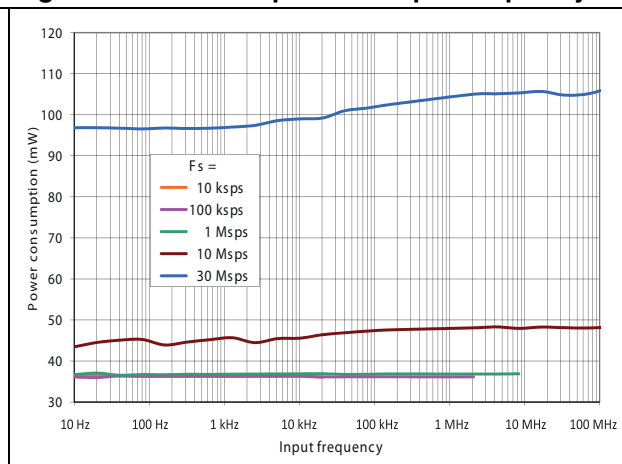

Figure 19. ENOB vs. sampling frequency

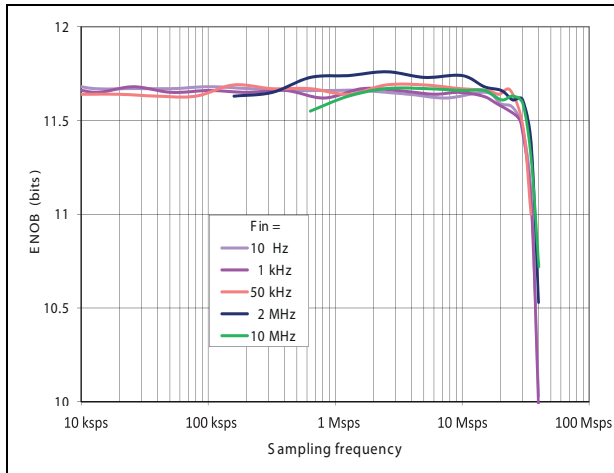

Figure 20. SINAD vs. sampling frequency

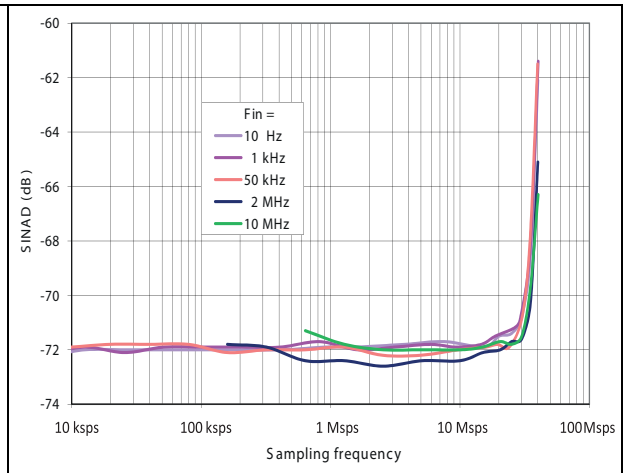

Figure 21. THD vs. sampling frequency

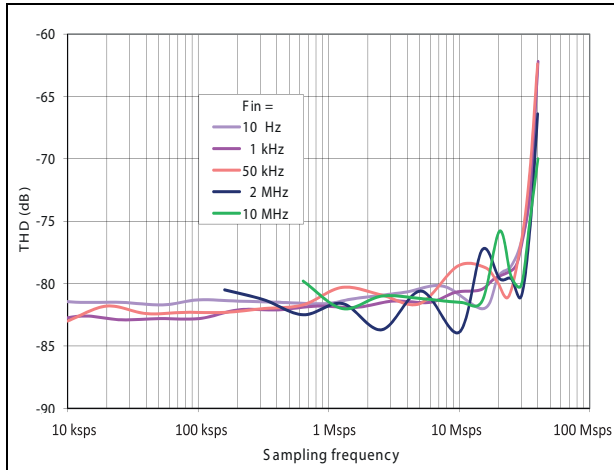

Figure 22. SNR vs. sampling frequency

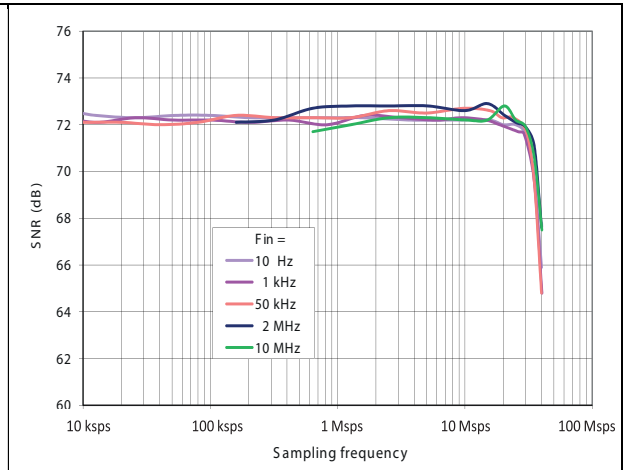

Figure 23. SFDR vs. sampling frequency

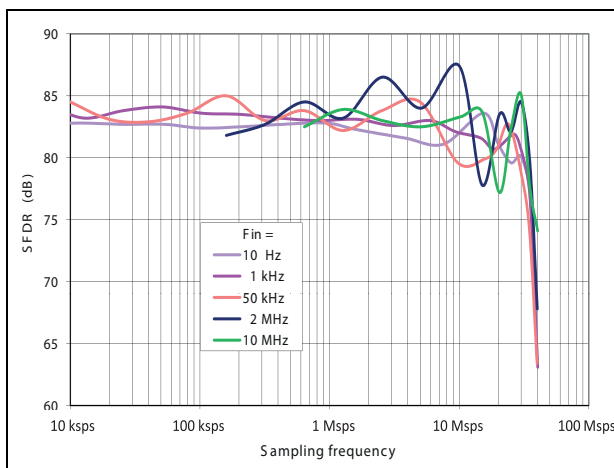

Figure 24. Power consumption vs. sampling frequency

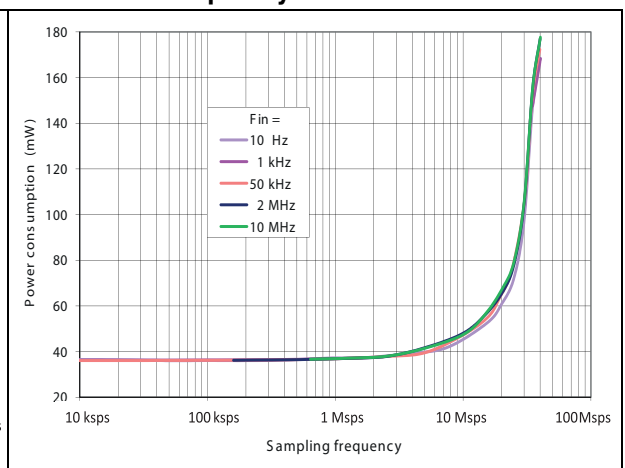

Figure 25. ENOB vs. VREFP

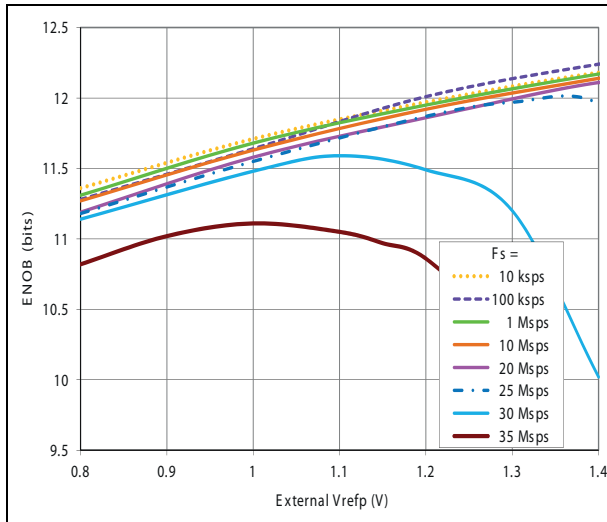

Figure 26. SINAD vs. VREFP

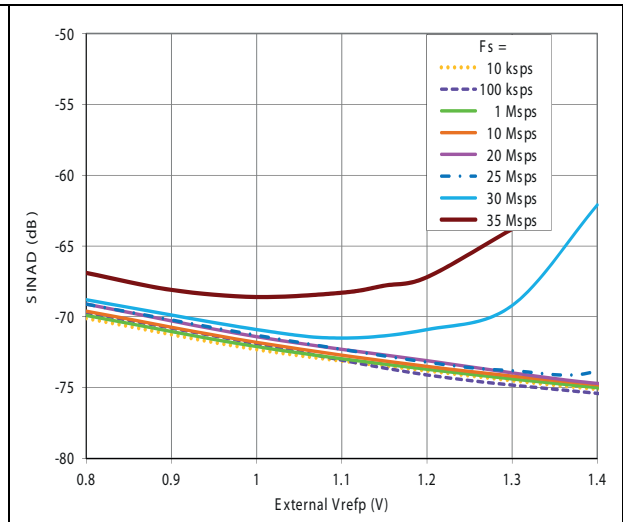

Figure 27. SNR vs. VREFP

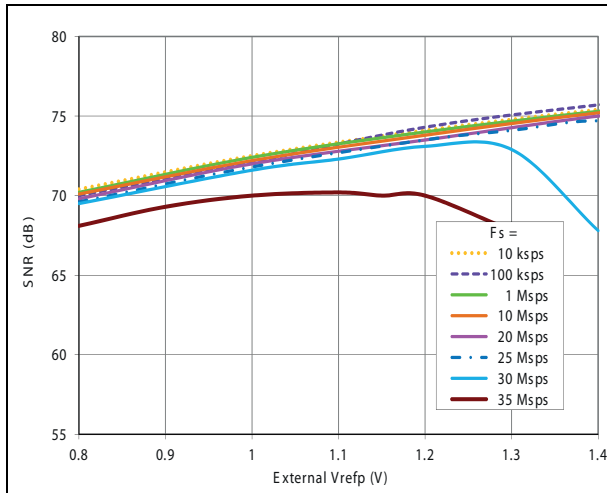

Figure 28. THD vs. VREFP

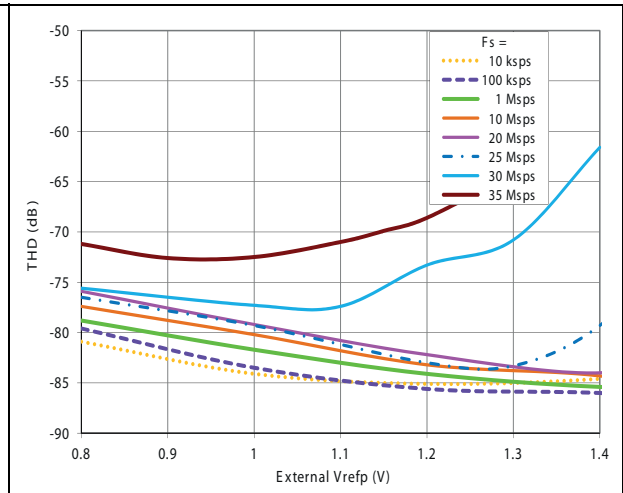

Figure 29. ENOB vs. sine clock, diff. input

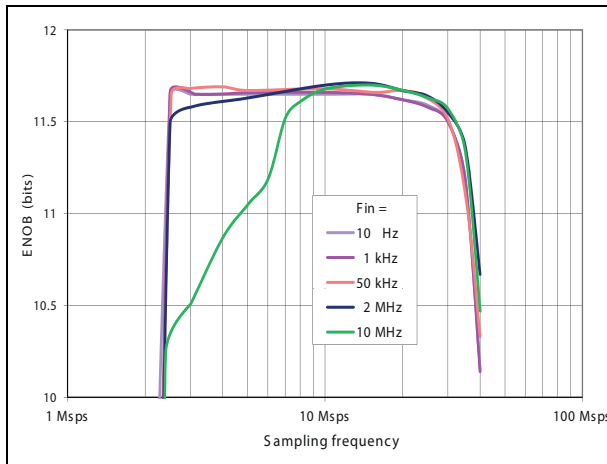

Figure 30. Clock threshold vs. temperature

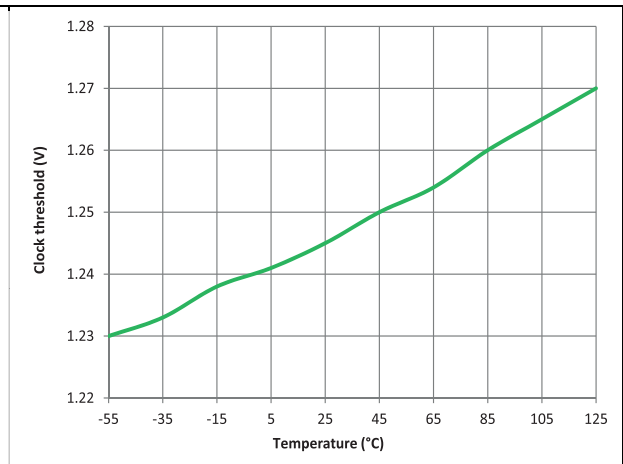

Figure 31. ENOB vs. temperature

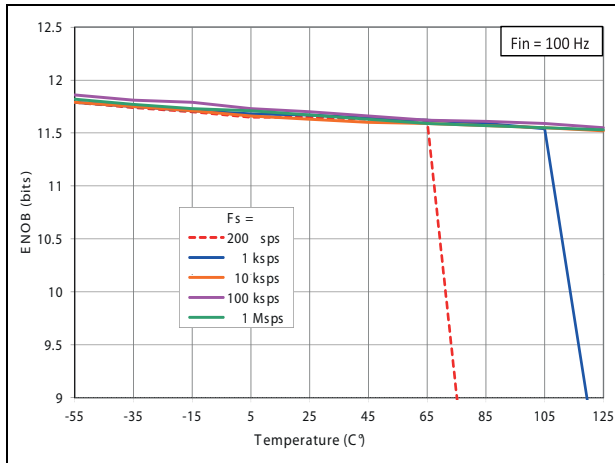

Figure 32. Power consumption vs. temp.

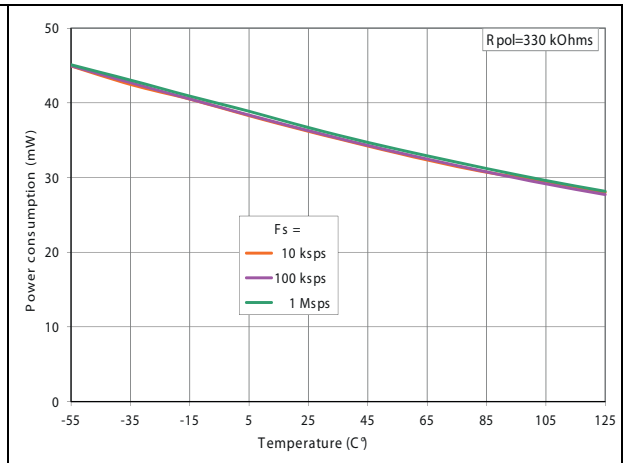

Figure 33. DNL, differential input

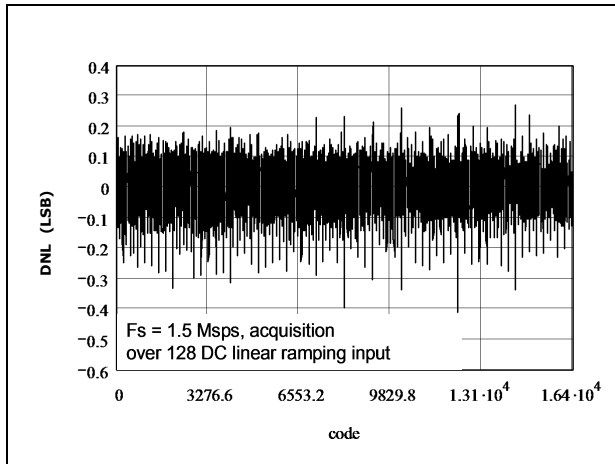
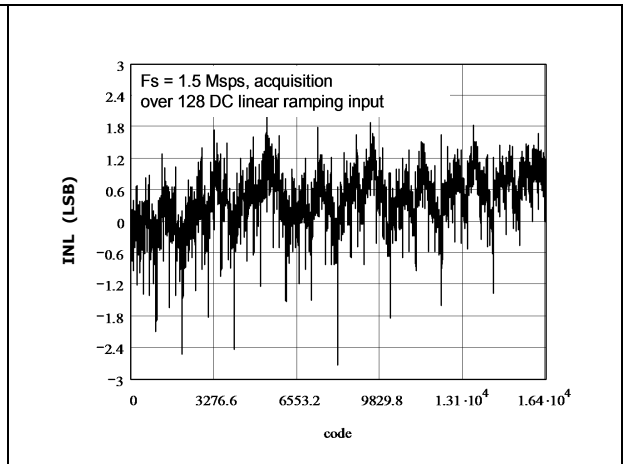

Figure 34. INL, differential input



2.5 Results for single ended input

Setup

- $AVCC = DVCC = VCCBI = VCCBE = 2.5\text{ V}$
- $VREFP = 1\text{ V}$
- $VREFM = 0\text{ V}$
- $INCM = V_{in}/2$
- $REFMODE = 1$ (internal references are disabled)
- $V_{in} = 1\text{ V}_{pp}$
- $T_{amb} = 25\text{ }^{\circ}\text{C}$
- A square clock is applied

Unless other test conditions are specified.

In the following graphs, the input signal is seldom full scale.

Figure 35. Single-ended input configuration

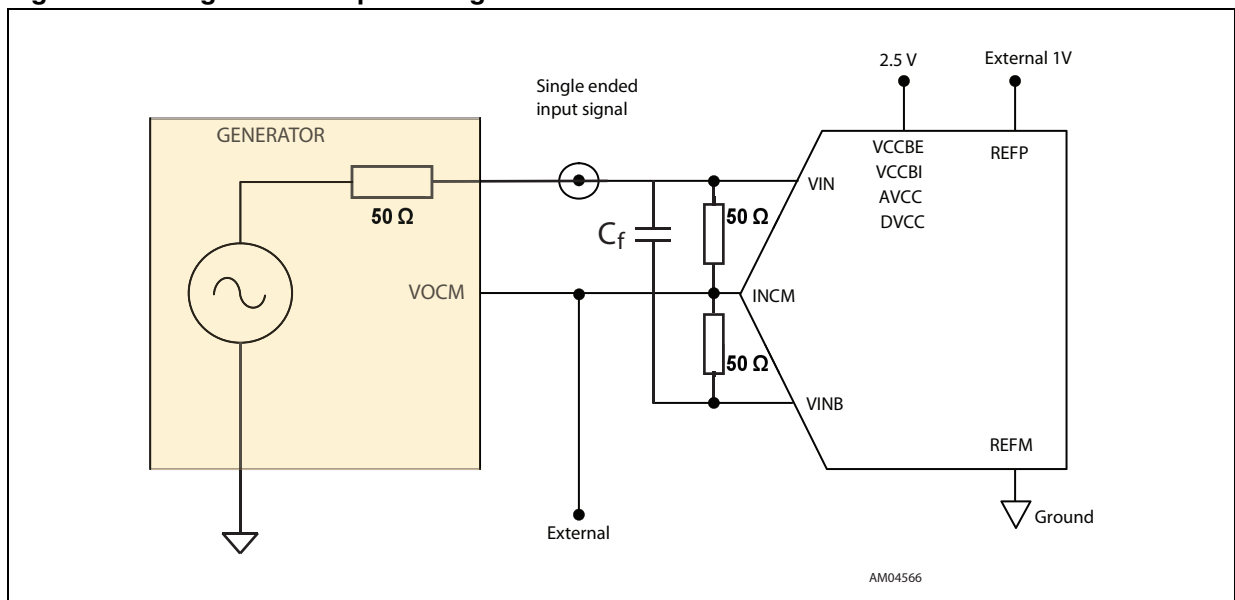

C_f is a filter capacitor to cut the HF noise. Its value is 10 nF for input frequencies equal to or below 20 kHz. The value of the capacitor is divided by two when the input frequency is multiplied by 2.

Figure 36. ENOB vs. Fin, single-ended

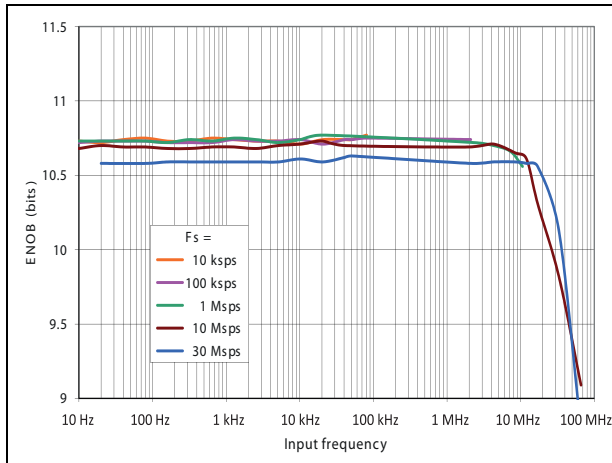

Figure 37. SINAD vs. Fin, single-ended

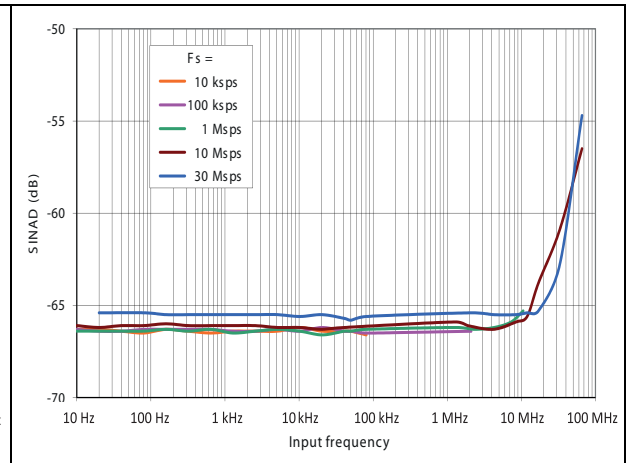

Figure 38. THD vs. Fin, single-ended

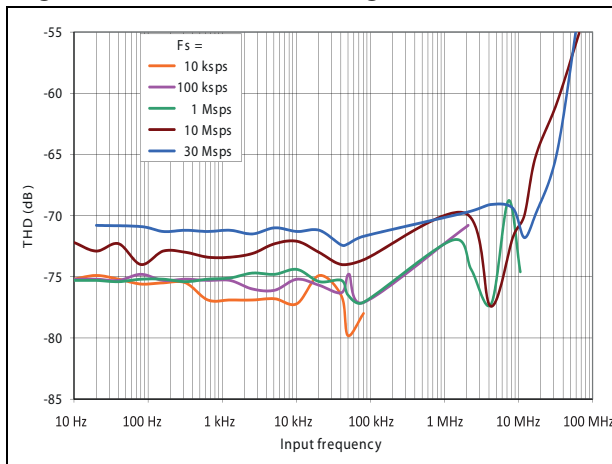

Figure 39. SNR vs. Fin, single-ended

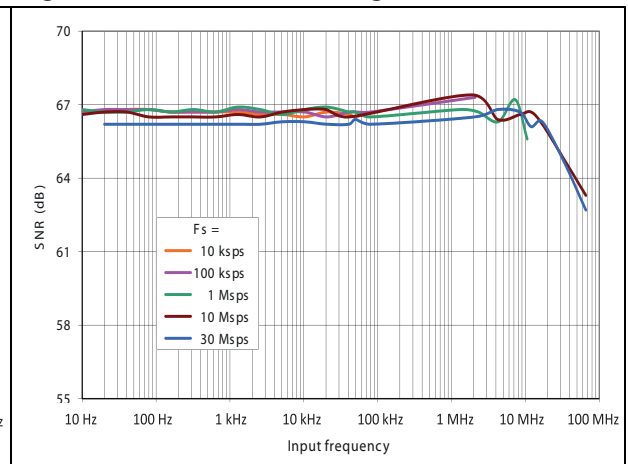

Figure 40. SFDR vs. Fin, single-ended

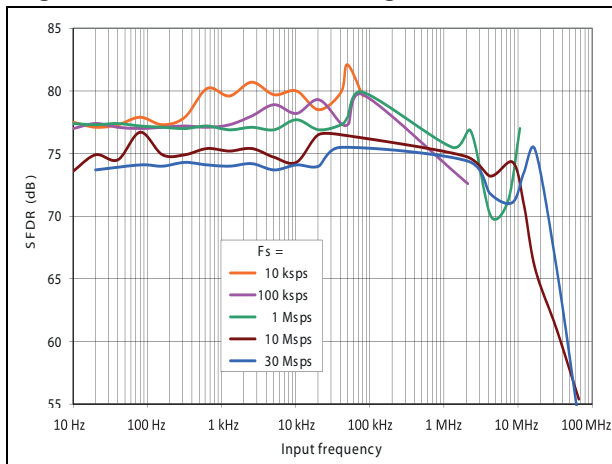

Figure 41. Power consumption vs. Fin

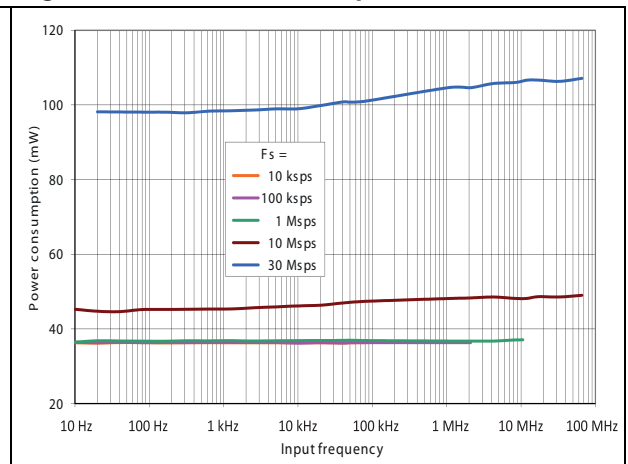

Figure 42. ENOB vs. Vin, Fin 1 kHz, Vrefp = 0.8 V

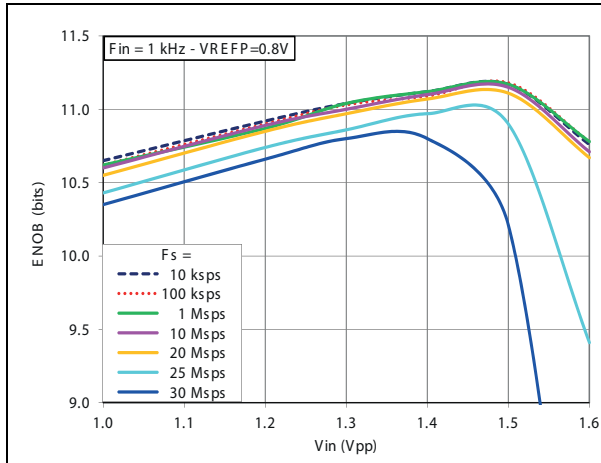

Figure 43. ENOB vs Vin, Fin = 2 MHz, Vrefp = 0.8 V

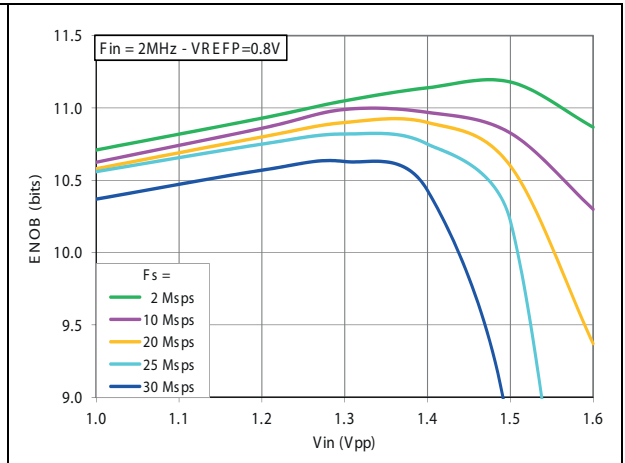

Figure 44. ENOB vs. Vin, Fin 1 kHz, Vrefp = 1.0 V

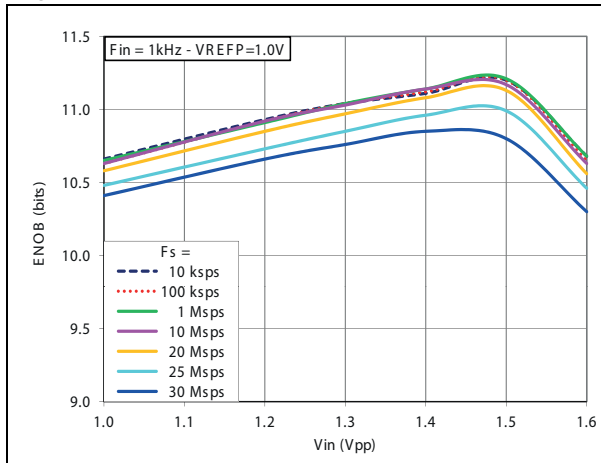

Figure 45. ENOB vs Vin, Fin = 2 MHz, Vrefp = 1.0 V

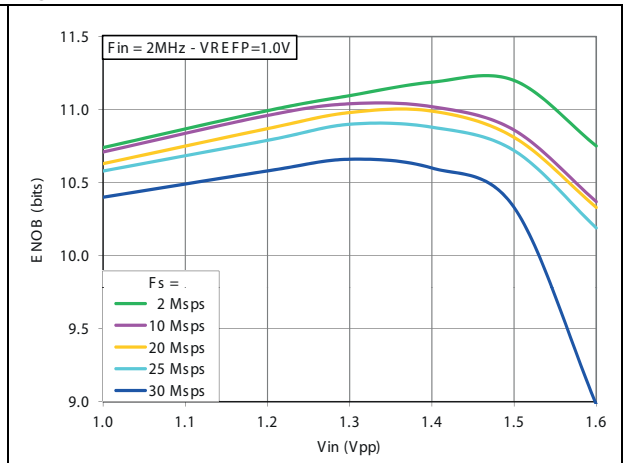

Figure 46. ENOB vs. Vin, Fin 1 kHz, Vrefp = 1.2 V

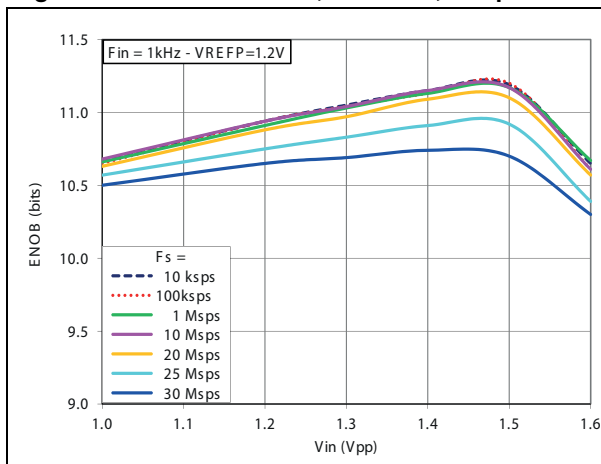

Figure 47. ENOB vs Vin, Fin = 2 MHz, Vrefp = 1.2 V

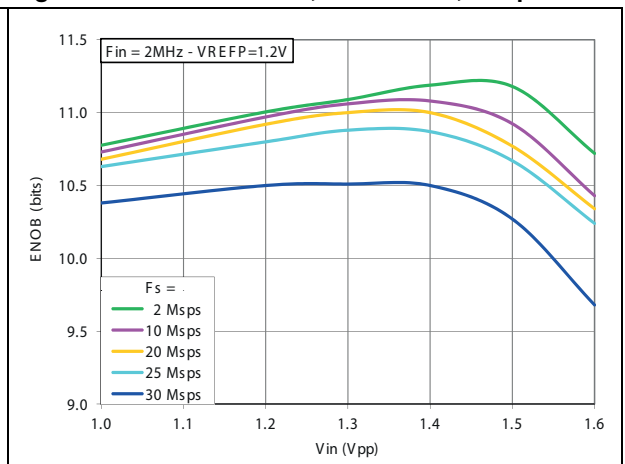

Figure 48. ENOB vs. Vin, Fin 1 kHz, Vrefp = 1.4 V

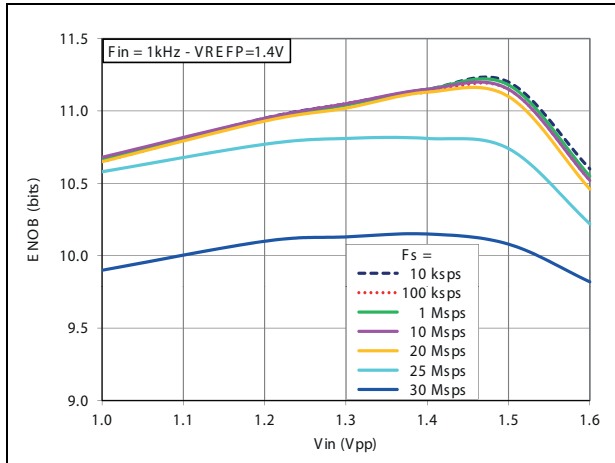
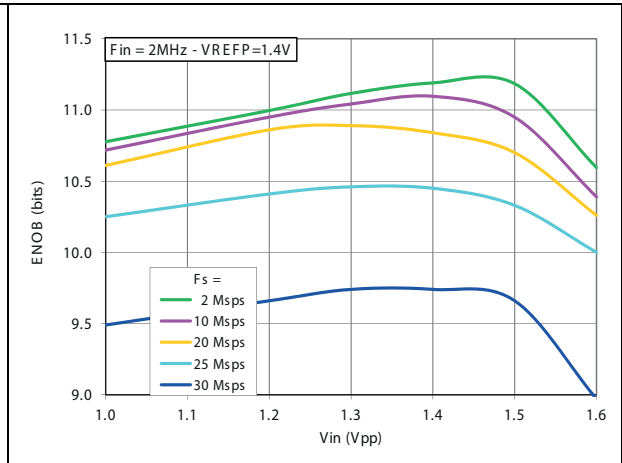

Figure 49. ENOB vs Vin, Fin = 2 MHz, Vrefp = 1.4 V



3 User manual

3.1 Optimizing the power consumption

The polarization current in the input stage is set by an external resistor (R_{pol}). When selecting the resistor value, it is possible to optimize the power consumption according to the sampling frequency of the application. For this purpose, an external R_{pol} resistor is placed between the IPOL pin and the analog ground.

The values in [Figure 50](#) are achieved with $VREFP = 1\text{ V}$, $VREFM = 0\text{ V}$, $INCM = 0.5\text{ V}$ and the input signal is 2 Vpp with a differential DC connection. If the conditions are changed, the R_{pol} resistor varies slightly.

[Figure 50](#) shows the optimum R_{pol} resistor value to obtain the best ENOB value. It also shows the minimum and maximum values to get good results. ENOB decreases by approximately 0.2 dB when you change R_{pol} from optimum to maximum or minimum.

If R_{pol} is higher than the maximum value, there is not enough polarization current in the analog stage to obtain good results. If R_{pol} is below the minimum, THD increases significantly.

Therefore, the total dissipation can be adjusted across the entire sampling range to fulfill the requirements of applications where power saving is critical.

For sampling frequencies below 2 MHz, the optimum resistor value is approximately 400 kOhms.

Figure 50. R_{pol} values vs. F_s

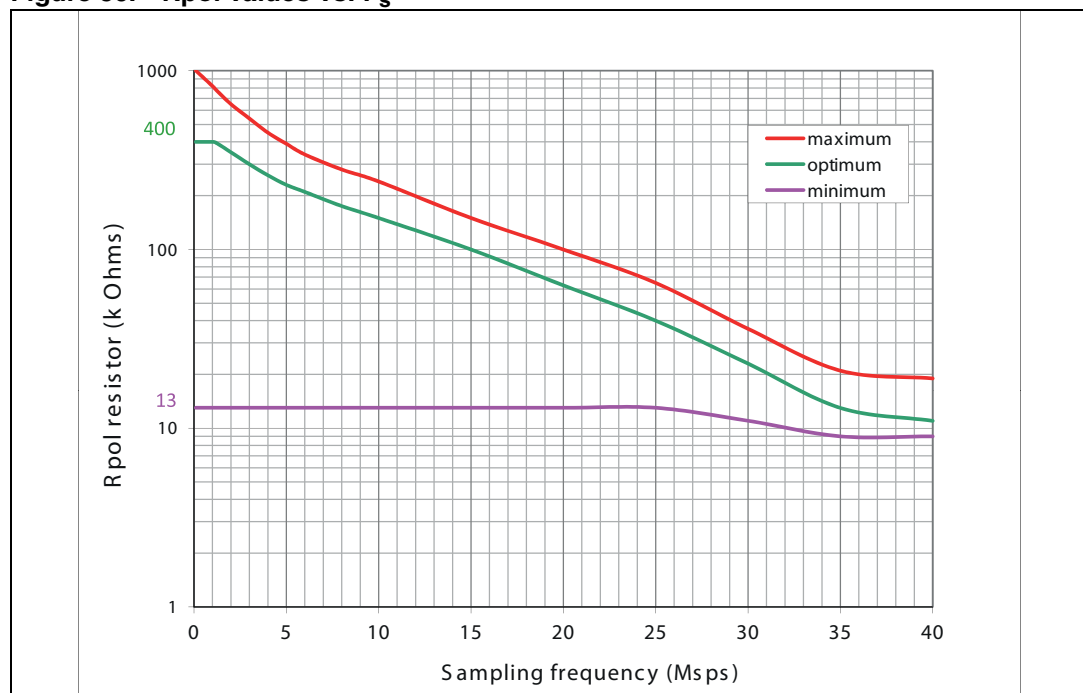

The power consumption depends on the R_{pol} value and the sampling frequency. In [Figure 51](#), it is shown with the internal references disabled ($REFMODE = 1$) and R_{pol} defined in [Figure 50](#) as the optimum.

Figure 51. Power consumption values vs. F_s with internal references disabled

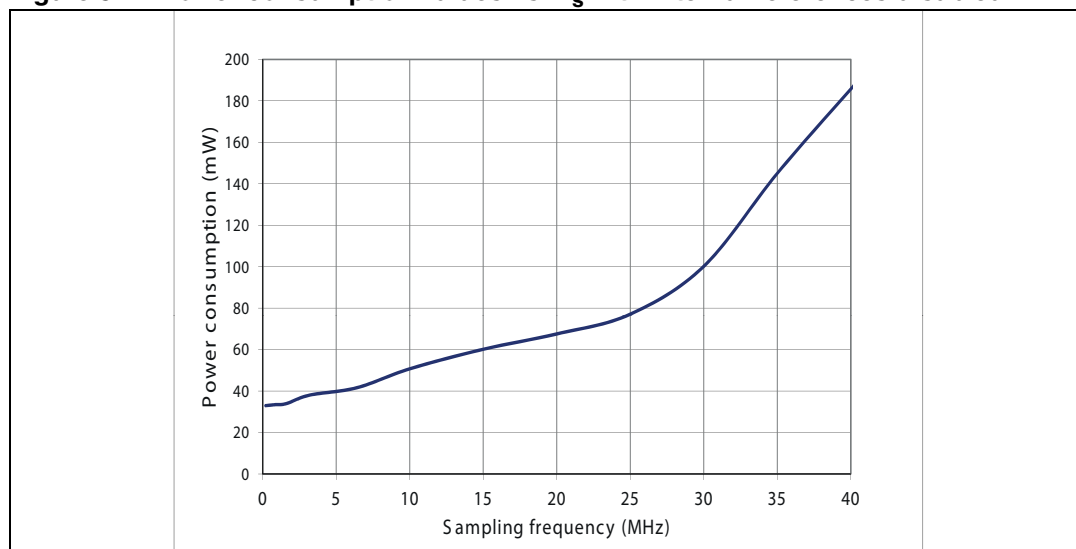

3.2 Driving the analog input

The input frequency can range from DC to tens of MHz.

The input stages (VIN and VINB) have a special design that limits the input amplitude. For each of them, the maximum input voltage is about 1.6 V for low sampling frequencies and less for high sampling frequencies. Low voltage is ground.

Consequently, the maximum input voltage read by the ADC for Single-ended mode is 1.6 V regardless of the VREFP and VREFM voltages.

3.2.1 Differential mode

The INCM value must be equal to the medium input voltage value.

In differential mode, high sampling limitation is seen in [Figure 25](#).

For all input frequencies, it is mandatory to add a capacitor on the PCB (between VIN and VINB) to cut the HF noise. The lower the frequency, the higher the capacitor.

The full-scale range is twice the difference between Vrep and Vrefm.

Figure 52. Equivalent VIN - VINB (differential input)

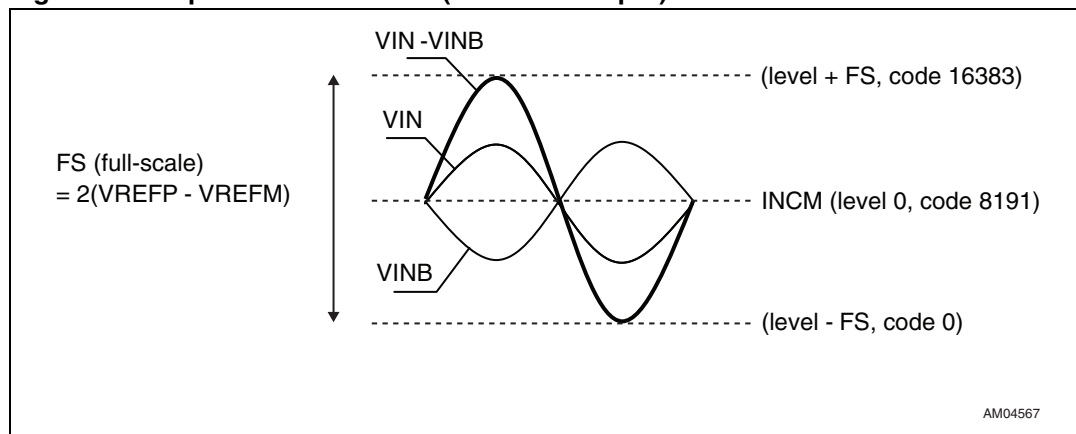

Table 12. Differential mode output codes

Vin - Vinb =	DFSB = 1	DFSB = 0
+ (VREFP-VREFM)	3FFF	1FFF
0	1FFF	3FFF
- (VREFP-VREFM)	0000	2000

The RHF1401 is designed to obtain optimum performance when driven on differential inputs with a differential amplitude of two volts peak-to-peak ($2 V_{pp}$). This is the result of $1 V_{pp}$ on the VIN and VINB inputs in phase opposition.

The RHF1401 is specifically designed to meet sampling requirements for intermediate frequency (IF) input signals. In particular, the track-and-hold in the first stage of the pipeline is designed to minimize the linearity limitations as the analog frequency increases.

Figure 53. 2 V_{pp} differential input

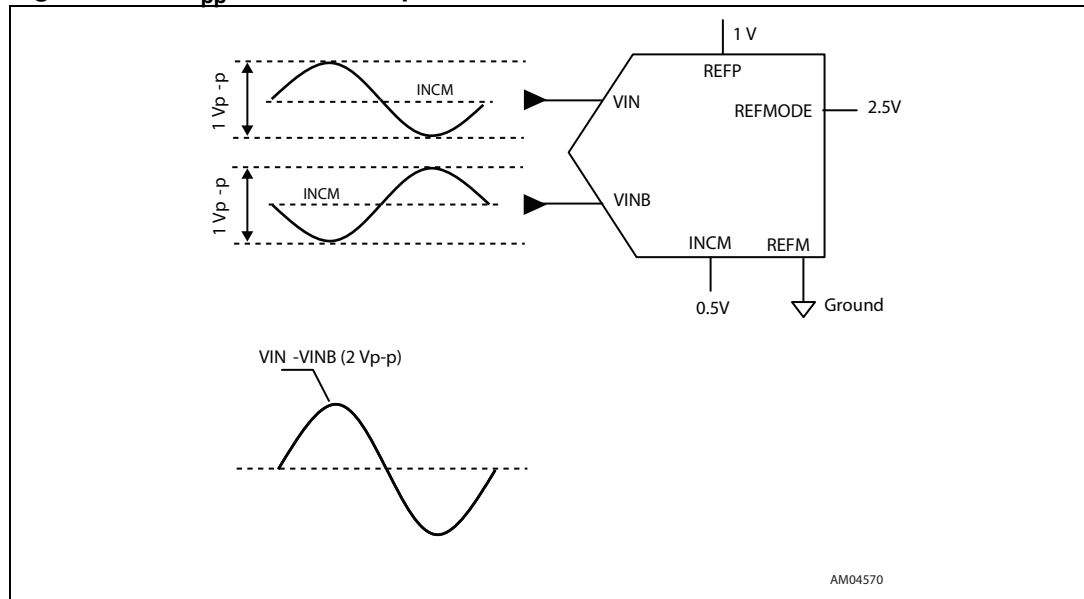
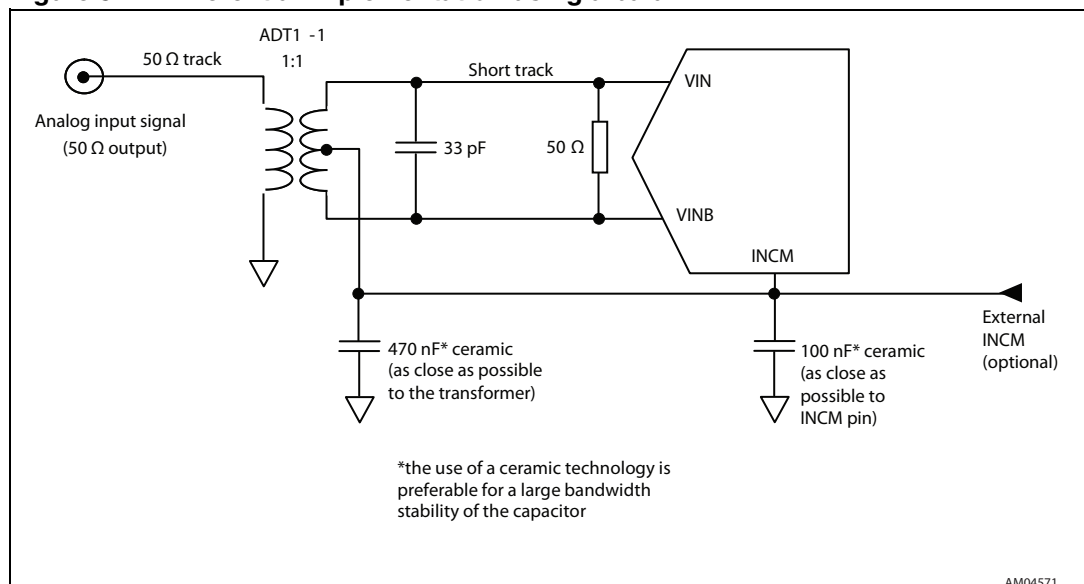

Figure 54 shows a differential input solution. The input signal is fed to the transformer's primary, while the secondary drives both ADC inputs. The transformer must be matched with generator output impedance: 50 Ω in this case for proper matching with a 50 Ω generator. The tracks between the secondary and VIN and VINB pins must be as short as possible.

Figure 54. Differential implementation using a balun



The input common-mode voltage of the ADC (INCM) is connected to the center tap of the transformer's secondary in order to bias the input signal around the common voltage (see Table 7: Internal reference voltage). The INCM is decoupled to maintain a low noise level on this node. Ceramic technology for decoupling provides good capacitor stability across a wide bandwidth.

3.2.2 Single-ended mode

Figure 55. Optimized single-ended configuration (DC coupling), external REFP

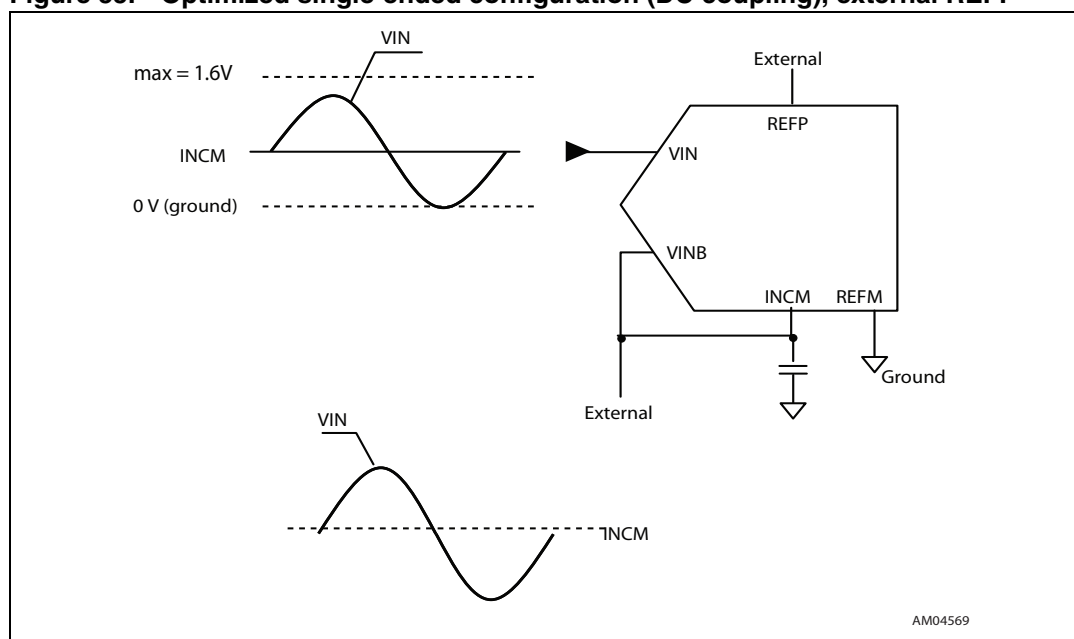

Table 13. Single-ended mode output codes with Vinb = INCM

Vin =	DFSB = 1	DFSB = 0
$INCM + (VREFP - VREFM)$	3FFF	1FFF
INCM	1FFF	3FFF
$INCM - (VREFP - VREFM)$	0000	2000

The RHF1401 is designed for use in a differential input configuration. Nevertheless, it can achieve good performance in a single-ended input configuration. In single-ended, performances depend on the input voltage, input frequency, voltage of references and sampling frequency (refer to [Figure 42.](#) to [Figure 49.](#))

VREFP and INCM internal voltage references are not adapted to Single-ended mode.

Some applications may require a single-ended input, which can easily be achieved with the configuration shown in [Figure 56](#), [Figure 57](#) for AC coupling or [Figure 35](#). for DC coupling. However, with this type of configuration, a degradation in the rated performance of the RHF1401 may occur compared with a differential configuration. A sufficiently decoupled DC reference should be used to bias the RHF1401 inputs. An AC-coupled analog input can also be used and the DC analog level set with a high value resistor R (6 kΩ to 100 kΩ) connected to a proper DC source. Cin and R behave like a high-pass filter and are calculated to set the lowest possible cut-off frequency.

Each input is limited to about 1.6 V due to the CMOS transistor on the input path. Voltage can be a bit more or less than 1.6 V depending on temperature, AVCC, and variations from one die to another (see [Figure 3](#) for the analog input schematic). This “input limitation” is independent of the VREFP and VREFM values.

The OR pin should rise to 1 when the signal is out of range. However, when $V_{REFP} = 0.8\text{ V}$, $V_{REFM} = 0\text{ V}$, and input voltage max = 1.6 V, the ADC may not read the maximum input voltage due to the CMOS input transistor. Consequently, the OR pin does not rise to 1. To avoid this situation occurring, it is recommended to limit the input amplitude to 1.5 V, V_{REFP} to 0.75 V, and V_{REFM} to 0 V.

Figure 56. AC-coupling single-ended input configuration

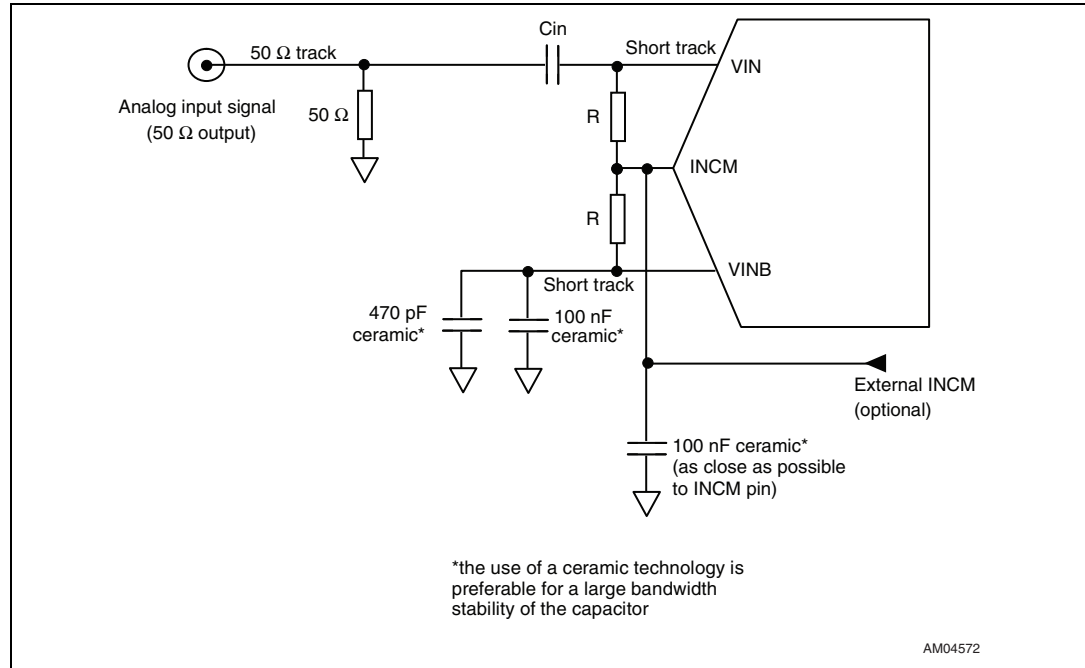
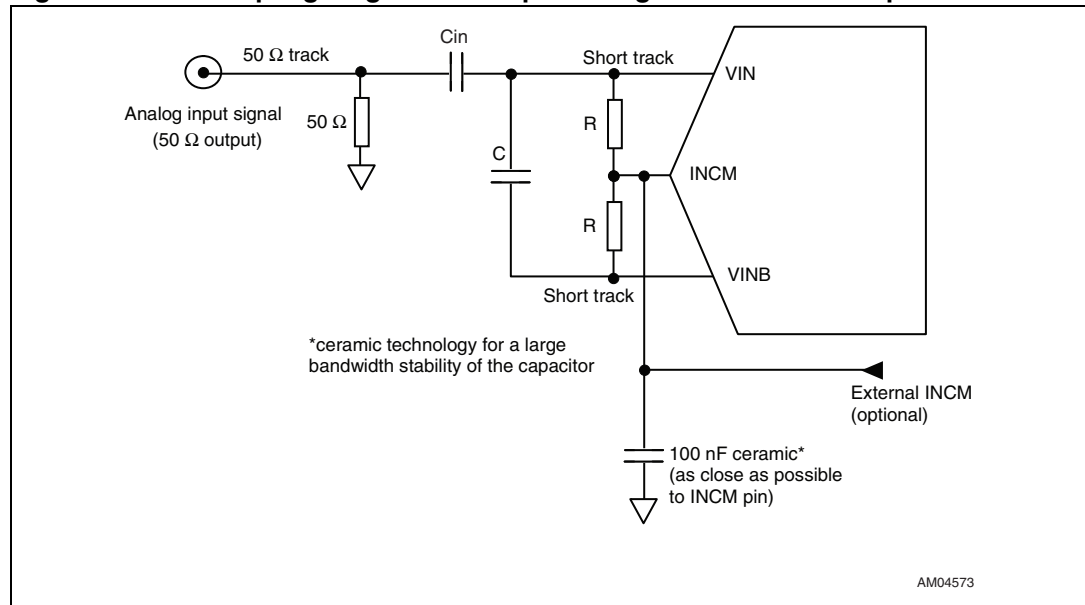

Figure 57. AC-coupling single-ended input configuration for low frequencies



The C capacitor is efficient in reducing noise at high frequencies. When coupled with the resistors, R and C together behave like a high-pass filter. For example, if $R = 10\text{ k}$ and $C = 33\text{ pF}$, the cut-off frequency of this filter equals 482 kHz.

3.3 Reference connections

3.3.1 Internal voltage reference

In standard configuration, the ADC is biased with two internal voltage references: VREFP and INCM. They should be decoupled to minimize low and high frequency noise. When the REFMODE pin is set to 0 both internal voltage references are enabled and they can drive external components or be forced by an external value.

The VREFM pin has no internal reference and must be connected to a voltage reference. It is usually connected to the analog ground.

Figure 58. Internal voltage reference setting

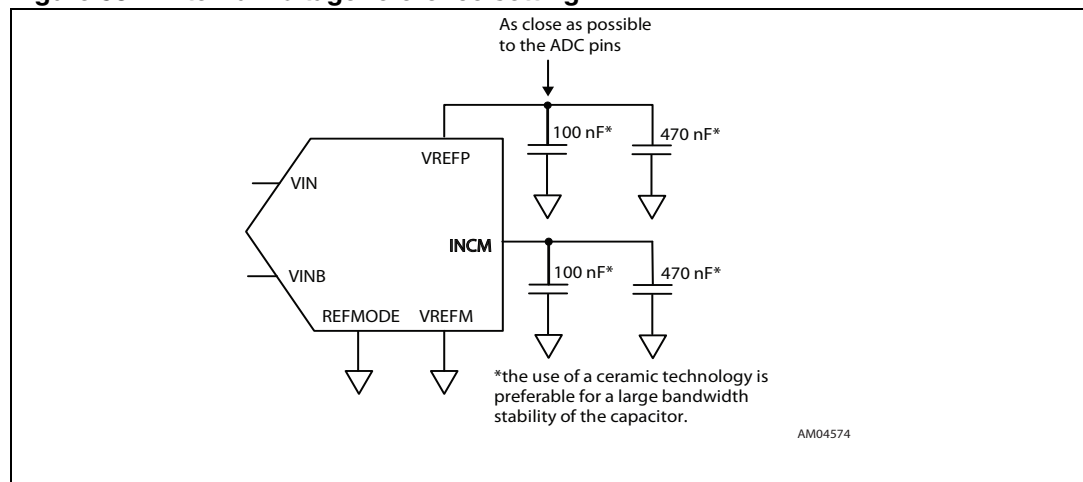

3.3.2 External voltage reference

External voltage references can be used for specific applications requiring better linearity, enhanced temperature behavior, or different voltage values (see [Table 7: Internal reference voltage](#)). Internal voltage references are disabled when the REFMODE pin is equal to 1. In this case, external voltage references must be applied to the device.

External voltage references can be applied when internal voltage references are disabled or not.

When internal voltage reference are disabled, ADC consumption is about 13 mA less than when they are enabled.

The external voltage references with the configuration shown in [Figure 59](#) and [Figure 60](#) can be used to obtain optimum performance. Decoupling is achieved by using ceramic capacitors, which provide optimum linearity versus frequency.

Figure 59. External voltage reference setting

Figure 60. Example with zeners

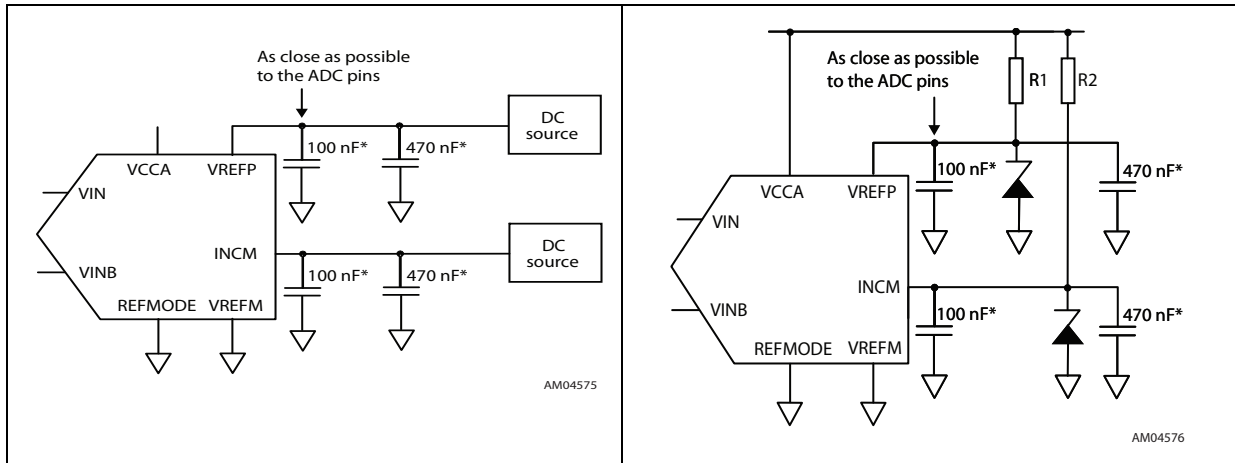

Note: **The use of ceramic technology is preferable to ensure large bandwidth stability of the capacitor.*

In multi-channel applications, the high impedance input (when REFMODE = 1) of the references allows one to drive several ADCs with only two voltage reference devices.

In Differential mode the voltage of the analog input common mode (INCM) should be around $V_{REFP}/2$. Higher levels introduce more distortion.

3.4 Clock input

The quality of the converter very much depends on the accuracy of the clock input in terms of jitter. The use of a low-jitter, crystal-controlled oscillator is recommended.

The following points should also be considered.

- The clock's power supplies must be independent of the ADC's output supplies to avoid digital noise modulation at the output.
- When powered-on, the circuit needs several clock periods to reach its normal operating conditions.

Figure 61. Clock input schematic

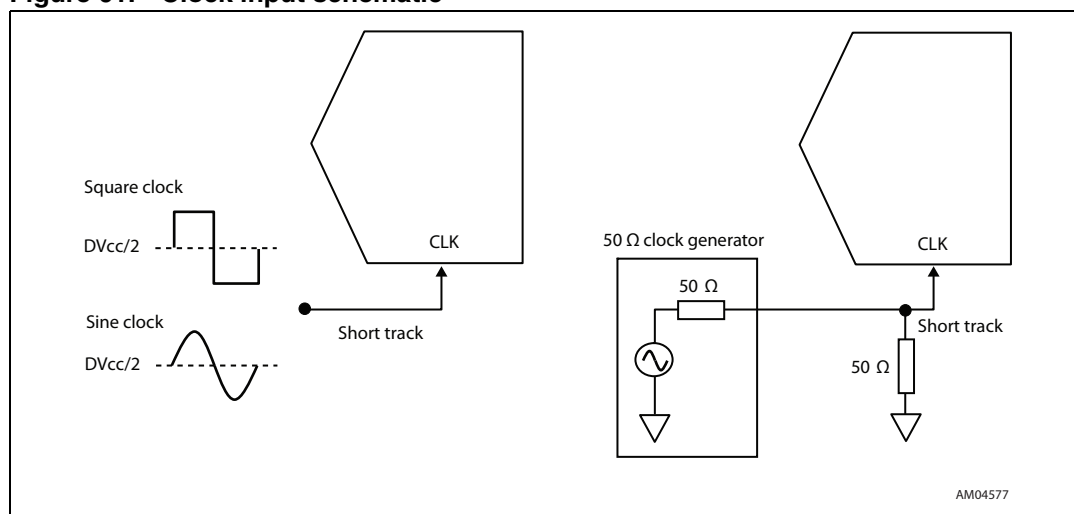

The signal applied to the CLK pin is critical to obtain full performance from the RHF1401. Below 10 MHz, the sine clock does not have transition times fast enough to achieve good performances. It is recommended to use a square signal with fast transition times and to place proper termination resistors as close as possible to the device.

The sampling instant is determined by the clock signal's rising edge. The jitter associated with this instant must be as low as possible to avoid SNR degradation on fast moving input signals. To make sure any error is less than 0.5 LSB, the total jitter T_j must satisfy the following condition for a full-scale input signal.

$$T_j < \frac{1}{\pi \cdot F_{in} \cdot 2^{n+1}}$$

For example, the total jitter with a 14-bit resolution for a 10 MHz full-scale input should be no more than 1 picosecond (rms).

In most cases, the clock signal jitter is responsible for noise. Therefore, you must pay attention to the clock signal when fast signals are acquired with a low frequency clock.

3.5 Operating modes

Extra functionalities are provided to simplify the application board as much as possible. The operating modes offered by the RHF1401 are described in [Table 14](#).

Table 14. RHF1401 operating modes

Inputs			Outputs		
Analog input differential amplitude	DFSB	OEB	OR	DR	Most significant bit (MSB)
$(V_{IN}-V_{INB})$ above maximum range	H	L	H	CLK	D13
	L	L	H	CLK	D13 complemented
$(V_{IN}-V_{INB})$ below minimum range	H	L	H	CLK	D13
	L	L	H	CLK	D13 complemented
$(V_{IN}-V_{INB})$ within range	H	L	L	CLK	D13
	L	L	L	CLK	D13 complemented
X	X	H	HZ ⁽¹⁾	HZ	HZ (all digital outputs are in high impedance)

1. High impedance.

3.5.1 Digital inputs

Data format select bit (DFSB): when set to low level (V_{IL}), the digital input DFBSD provides a two's complement digital output MSB. This can be of interest when performing some further signal processing. When set to high level (V_{IH}), DFBSD provides standard binary output coding (see [Table 12](#)).

Output enable bit (OEB): when set to low level (V_{IL}), all digital outputs remain active. When set to high level (V_{IH}), all digital output buffers are in a high impedance state while the converter goes on sampling. When OEB is set to a low level again, the data arrives on the output with a very short T_{on} delay. This feature enables the chip select of the device.

[Figure 11: Timing diagram](#) summarizes this functionality.

Reference mode control (REFMODE): this allows the internal or external settings of the voltage references VREFP and INCM. REFMODE = 0 for internal references, REFMODE = 1 for external references (and disables both references VREFP and INCM).

3.5.2 Digital outputs

Out of range (OR): this function is implemented on the output stage in order to set an "out-of-range" flag whenever the digital data is over the full-scale range. Typically, there is a detection of all data at '0' or all data at '1'. It sets an output signal OR, which is in a low level state (V_{OL}) when the data stays within the range, or in a high-level state (V_{OH}) when the data read by the ADC is out of range.

Data ready (DR): the Data Ready output is an image of the clock being synchronized on the output data (D0 to D13). This is a very helpful signal that simplifies the synchronization of the measurement equipment of the controlling DSP. Like all other digital outputs, DR goes into high impedance when OEB is set to a high level, as shown in [Figure 11: Timing diagram](#).

3.5.3 Digital output load considerations

The features of the internal output buffers limit the maximum load on the digital data output. In particular, the shape and amplitude of the Data Ready signal, toggling at the clock frequency, can be weakened by a higher equivalent load.

In applications that impose higher load conditions, it is recommended to use the falling edge of the master clock instead of the Data Ready signal. This is possible because the output transitions are internally synchronized with the falling edge of the clock.

Figure 62. Output buffer fall time

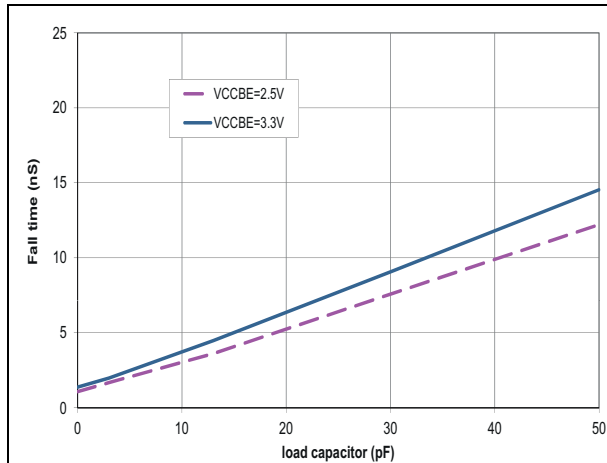
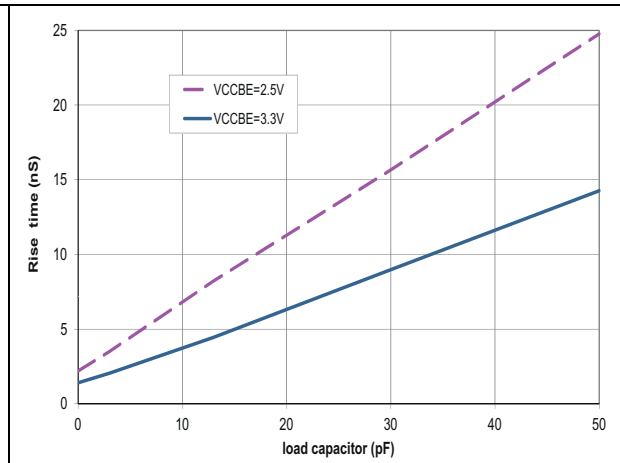

Figure 63. Output buffer rise time



3.6 PCB layout precautions

- The use of dedicated analog and digital ground planes on the PCB is recommended for high-speed circuit applications to provide low parasitic inductance and resistance. AGND is connected to the analog ground plane and DGND, GNDBI, GNDBE are connected to the digital ground plane.
- To minimize the transition current when the output changes, the capacitive load at the digital outputs must be reduced as much as possible by using the shortest-possible routing tracks. One way to reduce the capacitive load is to remove the ground plane under the output digital pins and layers at high sampling frequencies.
- The separation of the analog signal from the clock signal and digital outputs is mandatory to prevent noise from coupling onto the input signal.
- Power supply bypass capacitors must be placed as close as possible to the IC pins to improve high-frequency bypassing and reduce harmonic distortion.
- All leads must be as short as possible, especially for the analog input, so as to decrease parasitic capacitance and inductance.
- Choose the smallest-possible component sizes (SMD).

4 Definitions of specified parameters

4.1 Static parameters

Differential non-linearity (DNL)

The average deviation of any output code width from the ideal code width of 1 LSB.

Integral non-linearity (INL)

An ideal converter exhibits a transfer function that is a straight line from the starting code to the ending code. The INL is the deviation from this ideal line for each transition.

4.2 Dynamic parameters

Spurious free dynamic range (SFDR)

The ratio between the power of the worst spurious signal (not always a harmonic) and the amplitude of the fundamental tone (signal power) over the full Nyquist band. Expressed in dBc.

Total harmonic distortion (THD)

The ratio of the rms sum of the first five harmonic distortion components to the rms value of the fundamental line. Expressed in dB.

Signal to noise ratio (SNR)

The ratio of the rms value of the fundamental component to the rms sum of all other spectral components in the Nyquist band ($F_s/2$) excluding DC, fundamental and the first five harmonics. Reported in dB.

Signal-to-noise and distortion ratio (SINAD)

A similar ratio to the SNR but that includes the harmonic distortion components in the noise figure (not the DC signal). Expressed in dB. From SINAD, the effective number of bits (ENOB) can easily be deduced using the formula:

$$SINAD = 6.02 \times ENOB + 1.76 \text{ dB}$$

When the analog input signal is not full-scale (FS) but has an A_0 amplitude, the SINAD expression becomes:

$$SINAD = 6.02 \times ENOB + 1.76 \text{ dB} + 20 \log (A_0 / FS)$$

Analog input bandwidth

The maximum analog input frequency at which the spectral response of a full power signal is reduced by 3 dB. Higher values can be achieved with smaller input levels.

Pipeline delay

The delay between the initial sample of the analog input and the availability of the corresponding digital data output on the output bus. Also called data latency. Expressed as a number of clock cycles.

5 Package information

In order to meet environmental requirements, ST offers these devices in different grades of ECOPACK[®] packages, depending on their level of environmental compliance. ECOPACK[®] specifications, grade definitions and product status are available at: www.st.com. ECOPACK[®] is an ST trademark.

Figure 64. Ceramic SO-48 package mechanical drawing

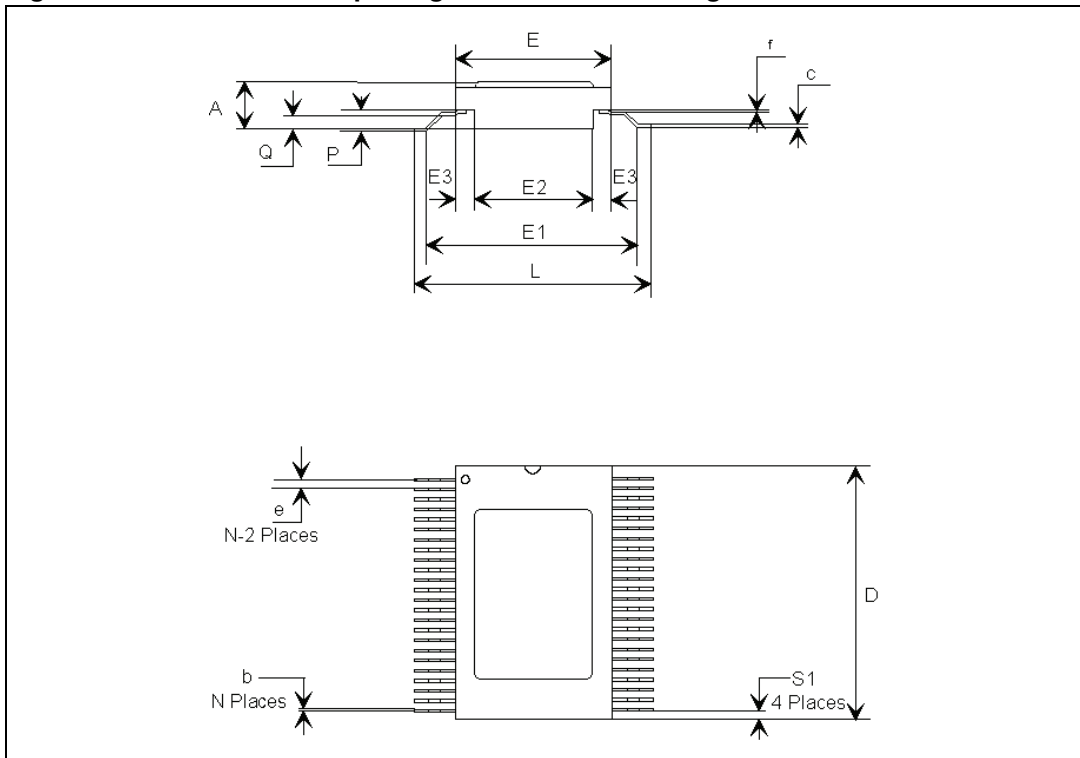

Note: The upper metallic lid is not electrically connected to any pins, nor to the IC die inside the package. Connecting unused pins or metal lid to ground or to the power supply will not affect the electrical characteristics.

Table 15. Ceramic SO-48 package mechanical data

Ref.	Dimensions					
	Millimeters			Inches		
	Min.	Typ.	Max.	Min.	Typ.	Max.
A	2.18	2.47	2.72	0.086	0.097	0.107
b	0.20	0.254	0.30	0.008	0.010	0.012
c	0.12	0.15	0.18	0.005	0.006	0.007
D	15.57	15.75	15.92	0.613	0.620	0.627
E	9.52	9.65	9.78	0.375	0.380	0.385
E1		10.90			0.429	
E2	6.22	6.35	6.48	0.245	0.250	0.255
E3	1.52	1.65	1.78	0.060	0.065	0.070
e		0.635			0.025	
f		0.20			0.008	
L	12.28	12.58	12.88	0.483	0.495	0.507
P	1.30	1.45	1.60	0.051	0.057	0.063
Q	0.66	0.79	0.92	0.026	0.031	0.036
S1	0.25	0.43	0.61	0.010	0.017	0.024

6 Ordering information

Table 16. Order codes

Order code	Quality level	Temp range	Package	Marking	Packing
RHF1401KSO1	Engineering model	-55 °C to +125 °C	SO-48	RHF1401KSO1	Strip pack
RHF1401KSO-01V	QMLV-Flight			5962F0626001VXC	

Note: Contact your local ST sales office for information regarding the specific conditions for products in die form and QML-Q versions.

7 Revision history

Table 17. Document revision history

Date	Revision	Changes
29-Jun-2007	1	<p>First public release.</p> <p>Failure immune and latchup immune value increased to 120 MeV-cm²/mg.</p> <p>Updated package mechanical information.</p> <p>Removed reference to non rad-hard components from <i>External references, common mode: on page 16</i>.</p>
29-Oct-2007	2	<p>Updated <i>Figure 1: RHF1401 block diagram</i>.</p> <p>Added explanation on <i>Figure 3: Timing diagram</i>.</p> <p>Added introduction to <i>Section 6: Typical performance characteristics</i>.</p> <p>Updated <i>Section 7.2: Clock signal requirements</i> and <i>Section 7.3: Power consumption optimization</i>.</p> <p>Added <i>Section 7.4: Low sampling rate recommendations</i>.</p> <p>Updated information on Data Ready signal in <i>Section 7.5: Digital inputs/outputs</i>.</p> <p>Added <i>Figure 24: Impact of clock frequency on RHF1401 performance</i> and <i>Figure 25: CLK signal derivation</i>.</p>
09-Nov-2009	3	<p>Changed input clock features in <i>Table 10</i>.</p> <p>Modified <i>Table 14</i>.</p> <p>Added <i>Figure 62 to Figure 42</i>.</p>
26-Feb-2010	4	<p>Modified <i>Figure 1: RHF1401 block diagram</i>.</p> <p>Added details for Tdr and changed values for Tpd in <i>Table 5: Timing characteristics</i>.</p> <p>Modified <i>Figure 11: Timing diagram</i>.</p> <p>Changed values for VREFP in <i>Table 4</i>.</p> <p>Changed Vin operating conditions in <i>Table 4, Figure 42</i> and <i>Figure 55</i>.</p> <p>Changed values for DNL in <i>Table 9</i>.</p>
13-Sep-2010	5	<p>Modified <i>Figure 1 on page 7</i> and <i>Figure 9 on page 11</i>.</p> <p>Added note <i>2. on page 13</i>.</p> <p>Modified C_{IN} typ value in <i>Table 6: Analog inputs</i> as per <i>Figure 3</i>.</p> <p>Modified <i>Figure 11: Timing diagram</i>.</p> <p>Replaced <i>Figure 18</i>.</p> <p>Added <i>Table 12: Output codes for DFSB = 1</i>.</p> <p>Modified <i>Figure 53: 2 Vpp differential input</i>.</p>
29-Jul-2011	6	<p>Added <i>Note: on page 31</i> and in the "Pin connections" diagram on the cover page.</p>

Table 17. Document revision history (continued)

Date	Revision	Changes
06-Apr-2012	7	Added Table 1: Device summary on cover page. Updated curves in Section 2.3: Electrical characteristics (after 300 kRad) . Modified Section 3.1: Optimizing the power consumption . Modified Section 3.2: Driving the analog input . Modified Section 3.3.1: Internal voltage reference . Modified Section 3.3.2: External voltage reference . Modified Section 3.6: PCB layout precautions .
24-Oct-2012	8	Updated Table 1 Modified Figure 1: RHF1401 block diagram Modified Figure 4: Output buffers Modified Table 4 , Table 7 , and Table 8 Modified Section 2.4: Results for differential input Modified Section 2.5: Results for single ended input Added comments and changed layout of Section 3.2: Driving the analog input . Modified Table 12 Modified Figure 55 Added Table 13 Added comments to Section 3.3: Reference connections Modified Section 3.5.1: Digital inputs

Please Read Carefully:

Information in this document is provided solely in connection with ST products. STMicroelectronics NV and its subsidiaries ("ST") reserve the right to make changes, corrections, modifications or improvements, to this document, and the products and services described herein at any time, without notice.

All ST products are sold pursuant to ST's terms and conditions of sale.

Purchasers are solely responsible for the choice, selection and use of the ST products and services described herein, and ST assumes no liability whatsoever relating to the choice, selection or use of the ST products and services described herein.

No license, express or implied, by estoppel or otherwise, to any intellectual property rights is granted under this document. If any part of this document refers to any third party products or services it shall not be deemed a license grant by ST for the use of such third party products or services, or any intellectual property contained therein or considered as a warranty covering the use in any manner whatsoever of such third party products or services or any intellectual property contained therein.

UNLESS OTHERWISE SET FORTH IN ST'S TERMS AND CONDITIONS OF SALE ST DISCLAIMS ANY EXPRESS OR IMPLIED WARRANTY WITH RESPECT TO THE USE AND/OR SALE OF ST PRODUCTS INCLUDING WITHOUT LIMITATION IMPLIED WARRANTIES OF MERCHANTABILITY, FITNESS FOR A PARTICULAR PURPOSE (AND THEIR EQUIVALENTS UNDER THE LAWS OF ANY JURISDICTION), OR INFRINGEMENT OF ANY PATENT, COPYRIGHT OR OTHER INTELLECTUAL PROPERTY RIGHT.

UNLESS EXPRESSLY APPROVED IN WRITING BY TWO AUTHORIZED ST REPRESENTATIVES, ST PRODUCTS ARE NOT RECOMMENDED, AUTHORIZED OR WARRANTED FOR USE IN MILITARY, AIR CRAFT, SPACE, LIFE SAVING, OR LIFE SUSTAINING APPLICATIONS, NOR IN PRODUCTS OR SYSTEMS WHERE FAILURE OR MALFUNCTION MAY RESULT IN PERSONAL INJURY, DEATH, OR SEVERE PROPERTY OR ENVIRONMENTAL DAMAGE. ST PRODUCTS WHICH ARE NOT SPECIFIED AS "AUTOMOTIVE GRADE" MAY ONLY BE USED IN AUTOMOTIVE APPLICATIONS AT USER'S OWN RISK.

Resale of ST products with provisions different from the statements and/or technical features set forth in this document shall immediately void any warranty granted by ST for the ST product or service described herein and shall not create or extend in any manner whatsoever, any liability of ST.

ST and the ST logo are trademarks or registered trademarks of ST in various countries.

Information in this document supersedes and replaces all information previously supplied.

The ST logo is a registered trademark of STMicroelectronics. All other names are the property of their respective owners.

© 2012 STMicroelectronics - All rights reserved

STMicroelectronics group of companies

Australia - Belgium - Brazil - Canada - China - Czech Republic - Finland - France - Germany - Hong Kong - India - Israel - Italy - Japan - Malaysia - Malta - Morocco - Philippines - Singapore - Spain - Sweden - Switzerland - United Kingdom - United States of America

www.st.com