

MOS INTEGRATED CIRCUIT

μ PD70F3040, 70F3040Y

V850/SV1™

32-/16-BIT SINGLE-CHIP MICROCONTROLLERS

DESCRIPTION

The μ PD70F3040 and μ PD70F3040Y are products that substitute flash memory for the mask ROM of the μ PD703039, 703040, 703041 and μ PD703039Y, 703040Y, 703041Y, respectively. Since the μ PD70F3040 and 70F3040Y can be read and written while mounted on the board, these products are ideal for evaluation during system development, multiple-version small-scale production or quick product release.

Detailed function descriptions are provided in the following user's manuals. Be sure to read them before designing.

V850/SV1 User's Manual Hardware: U14462E
 V850 Family™ User's Manual Architecture: U10243E

FEATURES

- Pin compatible with μ PD703039, 703040, 703041, 703039Y, 703040Y, and 703041Y
 - For mass production, these can be replaced by a mask ROM version.
 - μ PD70F3040 → μ PD703039, 703040, 703041
 - μ PD70F3040Y → μ PD703039Y, 703040Y, 703041Y

ORDERING INFORMATION

Part Number	Package
μ PD70F3040GM-UEU	176-pin plastic LQFP (fine-pitch) (24 × 24 mm)
μ PD70F3040YGM-UEU	176-pin plastic LQFP (fine-pitch) (24 × 24 mm)

DIFFERENCES BETWEEN V850/SV1 PRODUCTS

	Internal ROM	Internal RAM	l°C	V _{PP} Pin
μ PD70F3040	256 KB (flash memory)	16 KB	None	Provided
μ PD70F3040Y			Provided	
μ PD703039	256 KB (mask ROM)	8 KB	None	None
μ PD703039Y			Provided	
μ PD703040		16 KB	None	
μ PD703040Y			Provided	
μ PD703041	192 KB (mask ROM)	8 KB	None	
μ PD703041Y			Provided	

The information contained in this document is being issued in advance of the production cycle for the device. The parameters for the device may change before final production or NEC Corporation, at its own discretion, may withdraw the device prior to its production.
 Not all devices/types available in every country. Please check with local NEC representative for availability and additional information.

PIN CONFIGURATION

176-pin plastic LQFP (fine-pitch) (24 × 24 mm)

μPD70F3040GM-UEU

μPD70F3040YGM-UEU

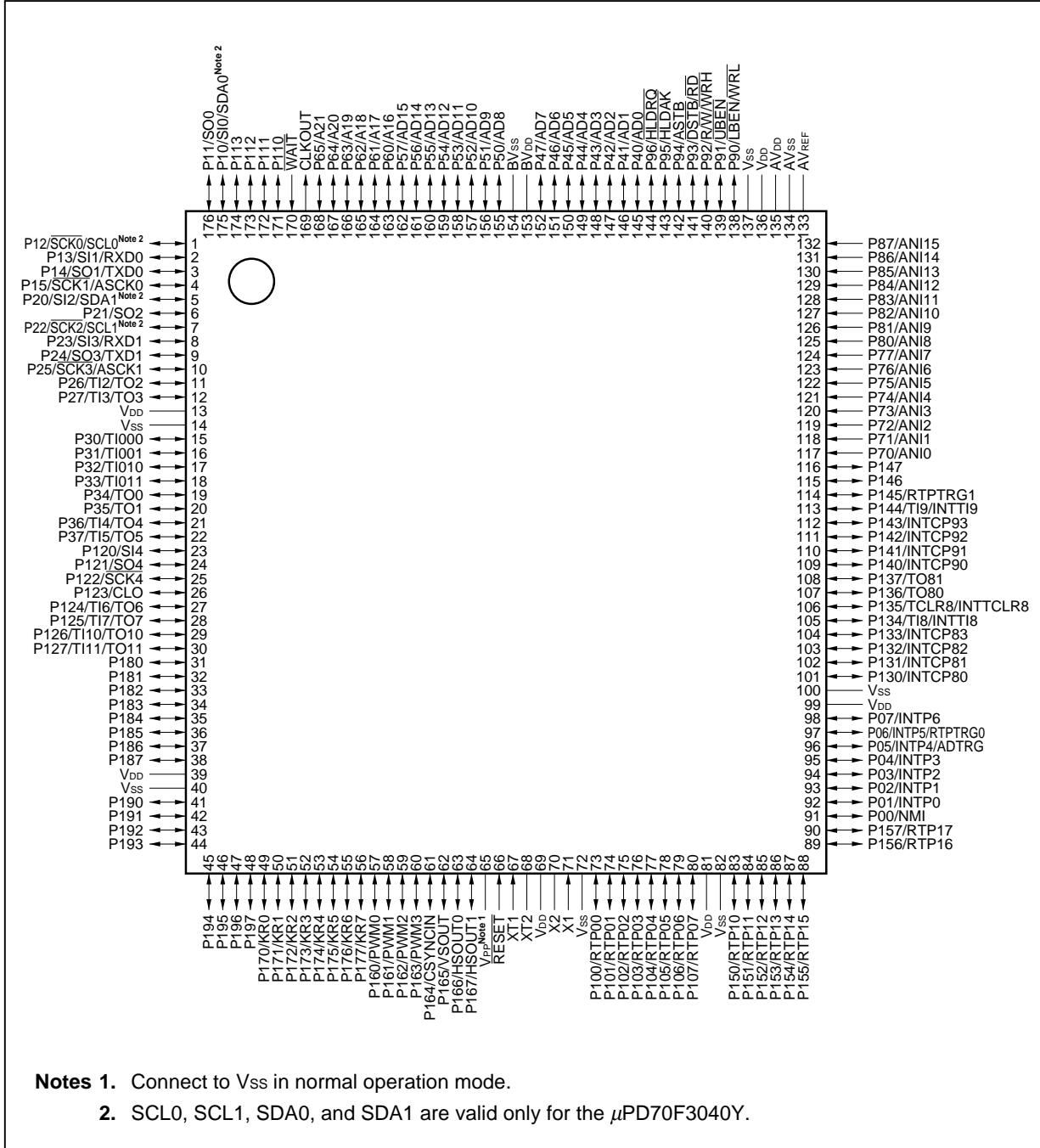

PIN IDENTIFICATION

A16 to A21:	Address Bus	P120 to P127:	Port 12
AD0 to AD15:	Address/Data Bus	P130 to P137:	Port 13
ADTRG:	AD Trigger Input	P140 to P147:	Port 14
ANI0 to ANI15:	Analog Input	P150 to P157:	Port 15
ASCK0, ASCK1:	Asynchronous Serial Clock	P160 to P167:	Port 16
ASTB:	Address Strobe	P170 to P177:	Port 17
AVDD:	Analog Power Supply	P180 to P187:	Port 18
AVREF:	Analog Reference Voltage	P190 to P197:	Port 19
AVSS:	Analog Ground	PWM0 to PWM3:	Pulse Width Modulation
BVDD:	Bus Interface Power Supply	\overline{RD} :	Read
BVSS:	Bus Interface Ground	\overline{RESET} :	Reset
CLKOUT:	Clock Output	RTP00 to RTP07,:	Real-time Output Port
CLO:	Clock Output (divided)	RTP10 to RTP17	
CSYNCIN:	Csync Input	RTPTRG0, RTPTRG1:	RTP Trigger Input
\overline{DSTB} :	Data Strobe	R \overline{W} :	Read/Write Status
\overline{HLDK} :	Hold Acknowledge	RXD0, RXD1:	Receive Data
\overline{HLDRQ} :	Hold Request	$\overline{SCK0}$ to $\overline{SCK4}$:	Serial Clock
HSOUT0, HSOUT1:	Hsync Output	SCL0, SCL1:	Serial Clock
INTCP80 to INTCP83,:	Interrupt Request from Peripherals	SDA0, SDA1:	Serial Data
INTCP90 to INTCP93,		SI0 to SI4:	Serial Input
INTP0 to INTP6,		SO0 to SO4:	Serial Output
INTTCLR8,		TCLR8:	Timer Clear
INTTI8, INTTI9		TI000, TI001, TI010,:	Timer Input
KR0 to KR7:	Key Return	TI011, TI2 to TI11	
\overline{LBEN} :	Lower Byte Enable	TO0 to TO7, TO80,:	Timer Output
NMI:	Non-Maskable Interrupt Request	TO81, TO10, TO11	
P00 to P07:	Port 0	TXD0, TXD1:	Transmit Data
P10 to P15:	Port 1	\overline{UBEN} :	Upper Byte Enable
P20 to P27:	Port 2	VDD:	Power Supply
P30 to P37:	Port 3	VPP:	Programming Power Supply
P40 to P47:	Port 4	VSOUT:	Vsync Output
P50 to P57:	Port 5	VSS:	Ground
P60 to P65:	Port 6	\overline{WAIT} :	Wait
P70 to P77:	Port 7	\overline{WRH} :	Write Strobe High Level Data
P80 to P87:	Port 8	\overline{WRL} :	Write Strobe Low Level Data
P90 to P96:	Port 9	X1, X2:	Crystal for Main System Clock
P100 to P107:	Port 10	XT1, XT2:	Crystal for Subsystem Clock
P110 to P113:	Port 11		

INTERNAL BLOCK DIAGRAM

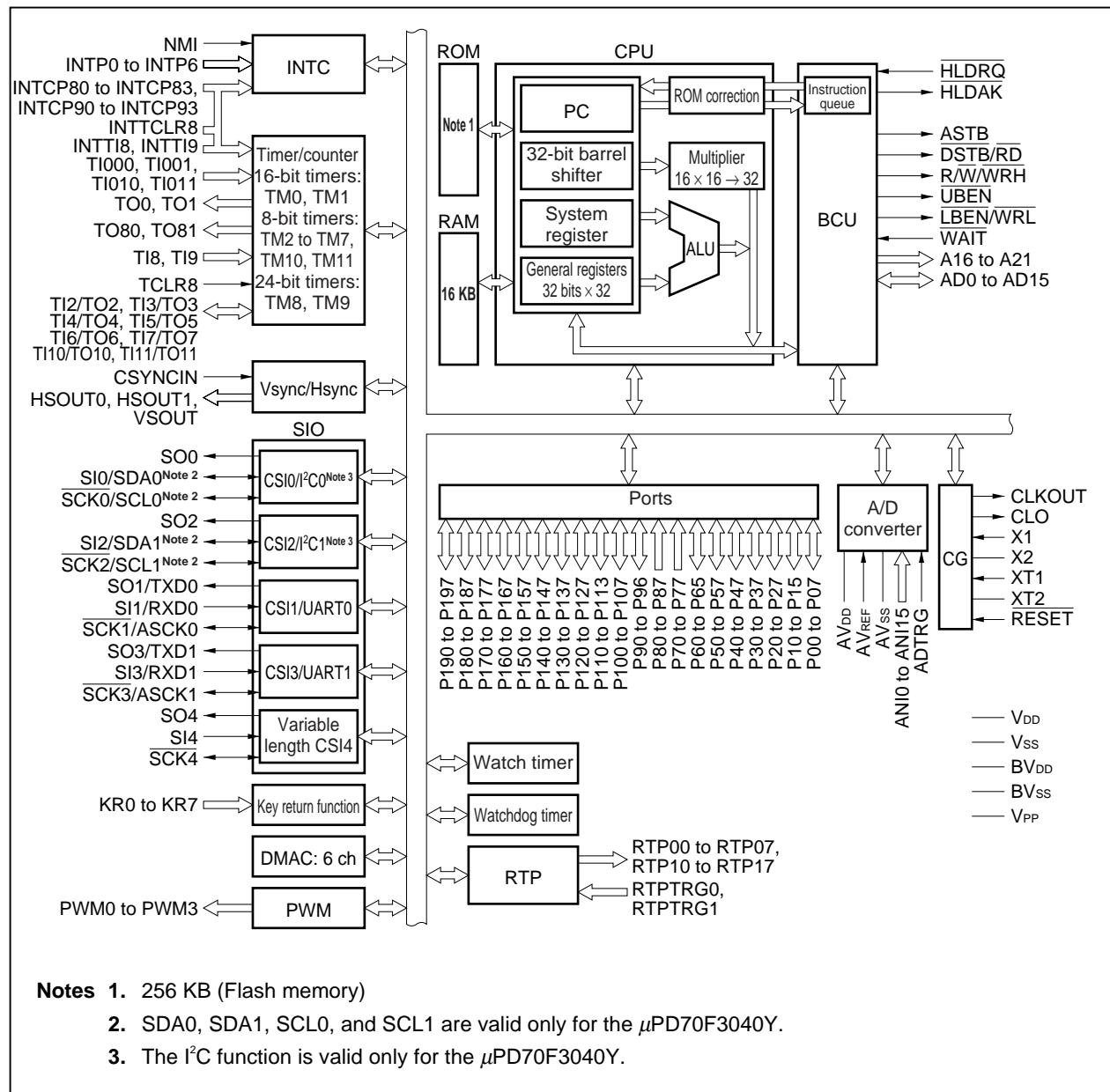

CONTENTS

- 1. PIN FUNCTIONS..... 6**
 - 1.1 Port Pins..... 6**
 - 1.2 Non-Port Pins..... 10**
 - 1.3 Pin I/O Circuits, I/O Buffer Supply, and Recommended Connection of Unused Pins 14**

- 2. ELECTRICAL SPECIFICATIONS..... 18**

- 3. PACKAGE DRAWING 39**

- 4. RECOMMENDED SOLDERING CONDITION..... 40**

1. PIN FUNCTIONS

1.1 Port Pins

(1/4)

Pin Name	I/O	PULL	Function	Alternate Function
P00	I/O	Yes	Port 0 8-bit I/O port Input/output mode can be specified in 1-bit units.	NMI
P01				INTP0
P02				INTP1
P03				INTP2
P04				INTP3
P05				INTP4/ADTRG
P06				INTP5/RTPTRG0
P07				INTP6
P10	I/O	Yes	Port 1 6-bit I/O port Input/output mode can be specified in 1-bit units.	SI0/SDA0
P11				SO0
P12				SCK0/SCL0
P13				SI1/RXD0
P14				SO1/TXD0
P15				SCK1/ASCK0
P20	I/O	Yes	Port 2 8-bit I/O port Input/output mode can be specified in 1-bit units.	SI2/SDA1
P21				SO2
P22				SCK2/SCL1
P23				SI3/RXD1
P24				SO3/TXD1
P25				SCK3/ASCK1
P26				TI2/TO2
P27				TI3/TO3
P30	I/O	Yes	Port 3 8-bit I/O port Input/output mode can be specified in 1-bit units.	TI000
P31				TI001
P32				TI010
P33				TI011
P34				TO0
P35				TO1
P36				TI4/TO4
P37				TI5/TO5
P40	I/O	No	Port 4 8-bit I/O port Input/output mode can be specified in 1-bit units.	AD0
P41				AD1
P42				AD2
P43				AD3
P44				AD4

Remark PULL: On-chip pull-up resistor

(2/4)

Pin Name	I/O	PULL	Function	Alternate Function
P45	I/O	No	Port 4 8-bit I/O port Input/output mode can be specified in 1-bit units.	AD5
P46				AD6
P47				AD7
P50	I/O	No	Port 5 8-bit I/O port Input/output mode can be specified in 1-bit units.	AD8
P51				AD9
P52				AD10
P53				AD11
P54				AD12
P55				AD13
P56				AD14
P57				AD15
P60	I/O	No	Port 6 6-bit I/O port Input/output mode can be specified in 1-bit units.	A16
P61				A17
P62				A18
P63				A19
P64				A20
P65				A21
P70	Input	No	Port 7 8-bit input port	ANI0
P71				ANI1
P72				ANI2
P73				ANI3
P74				ANI4
P75				ANI5
P76				ANI6
P77				ANI7
P80	Input	No	Port 8 8-bit input port	ANI8
P81				ANI9
P82				ANI10
P83				ANI11
P84				ANI12
P85				ANI13
P86				ANI14
P87				ANI15
P90	I/O	No	Port 9 7-bit I/O port Input/output mode can be specified in 1-bit units.	$\overline{\text{LBEN}}/\overline{\text{WRL}}$
P91				$\overline{\text{UBEN}}$
P92				$\overline{\text{R}}/\overline{\text{W}}/\overline{\text{WRH}}$
P93				$\overline{\text{DSTB}}/\overline{\text{RD}}$

Remark PULL: On-chip pull-up resistor

(3/4)

Pin Name	I/O	PULL	Function	Alternate Function
P94	I/O	No	Port 9 7-bit I/O port Input/output mode can be specified in 1-bit units.	ASTB
P95				HLDK
P96				HLDK
P100	I/O	Yes	Port 10 8-bit I/O port Input/output mode can be specified in 1-bit units.	RTP00
P101				RTP01
P102				RTP02
P103				RTP03
P104				RTP04
P105				RTP05
P106				RTP06
P107				RTP07
P110	I/O	No	Port 11 4-bit I/O port Input/output mode can be specified in 1-bit units.	—
P111				—
P112				—
P113				—
P120	I/O	No	Port 12 8-bit I/O port Input/output mode can be specified in 1-bit units.	SI4
P121				SO4
P122				SCK4
P123				CLO
P124				TI6/TO6
P125				TI7/TO7
P126				TI10/TO10
P127				TI11/TO11
P130	I/O	No	Port 13 8-bit I/O port Input/output mode can be specified in 1-bit units.	INTCP80
P131				INTCP81
P132				INTCP82
P133				INTCP83
P134				TI8/INTTI8
P135				TCLR8/INTTCLR8
P136				TO80
P137				TO81
P140	I/O	No	Port 14 8-bit I/O port Input/output mode can be specified in 1-bit units.	INTCP90
P141				INTCP91
P142				INTCP92
P143				INTCP93
P144				TI9/INTTI9
P145				RTPTRG1
P146				—
P147				—

Remark PULL: On-chip pull-up resistor

Pin Name	I/O	PULL	Function	Alternate Function
P150	I/O	No	Port 15 8-bit I/O port Input/output mode can be specified in 1-bit units.	RTP10
P151				RTP11
P152				RTP12
P153				RTP13
P154				RTP14
P155				RTP15
P156				RTP16
P157				RTP17
P160	I/O	No	Port 16 8-bit I/O port Input/output mode can be specified in 1-bit units.	PWM0
P161				PWM1
P162				PWM2
P163				PWM3
P164				CSYNCIN
P165				VSOUT
P166				HSOUT0
P167				HSOUT1
P170	I/O	Yes	Port 17 8-bit I/O port Input/output mode can be specified in 1-bit units.	KR0
P171				KR1
P172				KR2
P173				KR3
P174				KR4
P175				KR5
P176				KR6
P177				KR7
P180	I/O	No	Port 18 8-bit I/O port Input/output mode can be specified in 1-bit units.	-
P181				-
P182				-
P183				-
P184				-
P185				-
P186				-
P187				-
P190	I/O	No	Port 19 8-bit I/O port Input/output mode can be specified in 1-bit units.	-
P191				-
P192				-
P193				-
P194				-
P195				-
P196				-
P197				-

Remark PULL: On-chip pull-up resistor

1.2 Non-Port Pins

(1/4)

Pin Name	I/O	PULL	Function	Alternate Function
A16 to A21	Output	No	Address bus 16 to 21	P60 to P65
AD0 to AD7	I/O	No	Address/data multiplexed bus 0 to 15	P40 to P47
AD8 to AD15				P50 to P57
ADTRG	Input	Yes	A/D converter external trigger input	P05/INTP4
ANI0 to ANI7	Input	No	Analog input to A/D converter	P70 to P77
ANI8 to ANI15	Input	No		P80 to P87
ASCK0	Input	Yes	Baud rate clock input for UART0 and UART1	P15/ $\overline{\text{SCK1}}$
ASCK1				P25/ $\overline{\text{SCK3}}$
ASTB	Output	No	External address strobe signal output	P94
AV _{DD}	–	–	Positive power supply for A/D converter and ports used for alternate functions	–
AV _{REF}	Input	–	Reference voltage input for A/D converter	–
AV _{SS}	–	–	Ground potential for A/D converter and ports used for alternate functions	–
BV _{DD}	–	–	Positive power supply for bus interface and ports used for alternate functions	–
BV _{SS}	–	–	Ground potential for bus interface and ports used for alternate functions	–
CLKOUT	Output	–	Internal system clock output	–
CLO	Output	No	CLO output signal	P123
CSYNCIN	Input	No	Csync signal input	P164
$\overline{\text{DSTB}}$	Output	No	External data strobe signal output	P93/ $\overline{\text{RD}}$
HLD $\overline{\text{AK}}$	Output	No	Bus hold acknowledge output	P95
$\overline{\text{HLDRQ}}$	Input	No	Bus hold request input	P96
HSOUT0	Output	No	Hsync signal output before compensation	P166
HSOUT1			Hsync signal output after compensation	P167
INTCP80 to INTCP83	Input	No	External capture input for CC80 to CC83	P130 to P133
INTCP90 to INTCP93	Input	No	External capture input for CP90 to CP93	P140 to P143
INTP0 to INTP3	Input	Yes	External interrupt request input (analog noise elimination)	P01 to P04
INTP4			External interrupt request input (digital noise elimination)	P05/ADTRG
INTP5				P06/RTPTRG0
INTP6			External interrupt request input (digital noise elimination supporting remote controller)	P07

Remark PULL: On-chip pull-up resistor

(2/4)

Pin Name	I/O	PULL	Function	Alternate Function
INTTCLR8	Input	No	External interrupt request input (digital noise elimination)	P135/TCLR8
INTTI8	Input	No		P134/TI8
INTTI9				P144/TI9
KR0 to KR7	Input	Yes	Key return input	P170 to P177
$\overline{\text{LBEN}}$	Output	No	Lower byte enable signal output for external data bus	P90/ $\overline{\text{WRL}}$
NMI	Input	Yes	Non-maskable interrupt request input	P00
PWM0 to PWM3	Output	No	Output of PWM channels 0 to 3	P160 to P163
$\overline{\text{RD}}$	Output	No	Bus read strobe signal output	P93/ $\overline{\text{DSTB}}$
$\overline{\text{RESET}}$	Input	–	System reset input	–
RTP00 to RTP07	Output	Yes	Real-time output port	P100 to P107
RTP10 to RTP17				P150 to P157
RTPTRG0	Input	Yes	RTP external trigger input	P06
RTPTRG1		No		P146
$\overline{\text{R/W}}$	Output	No	External read/write status output	P92/ $\overline{\text{WRH}}$
RXD0	Input	Yes	Serial receive data input for UART0 and UART1	P13/SI1
RXD1				P23/SI3
$\overline{\text{SCK0}}$	I/O	Yes	Serial clock I/O for CSI0 to CSI3 (3-wire mode)	P12/SCL0
$\overline{\text{SCK1}}$				P15/ASCK0
$\overline{\text{SCK2}}$				P22/SCL1
$\overline{\text{SCK3}}$				P25/ASCK1
$\overline{\text{SCK4}}$		No	Variable-length CSI4 serial clock I/O	P122
SCL0	I/O	Yes	Serial clock I/O for I ² C0 and I ² C1 (μPD70F3040Y)	P12/ $\overline{\text{SCK0}}$
SCL1				P22/ $\overline{\text{SCK2}}$
SDA0	I/O	Yes	Serial transmit/receive data I/O for I ² C0 and I ² C1 (μPD70F3040Y)	P10/SI0
SDA1				P20/SI2
SI0	Input	Yes	Serial receive data input for CSI0 to CSI3 (3-wire mode)	P10/SDA0
SI1				P13/RXD0
SI2				P20/SDA1
SI3				P23/RXD1
SI4		No	Variable-length CSI4 serial receive data input (3-wire mode)	P120
SO0	Output	Yes	Serial transmit data output for CSI0 to CSI3	P11
SO1				P14/TXD0
SO2				P21
SO3				P24/TXD1
SO4		No	Variable-length CSI4 serial transmit data output	P121
TCLR8	Input	No	External clear input for TM8	P135/INTTCLR8

Remark PULL: On-chip pull-up resistor

(3/4)

Pin Name	I/O	PULL	Function	Alternate Function
TI000	Input	Yes	External count clock input/external capture trigger input for TM0	P30
TI001			External capture trigger input for TM0	P31
TI010			External count clock input/external capture trigger input for TM1	P32
TI011			External capture trigger input for TM1	P33
TI2			External count clock input for TM2	P26/TO2
TI3			External count clock input for TM3	P27/TO3
TI4			External count clock input for TM4	P36/TO4/A15
TI5			External count clock input for TM5	P37/TO5
TI6		No	External count clock input for TM6	P124/TO6
TI7			External count clock input for TM7	P125/TO7
TI8			External count clock input for TM8	P134/INTTI8
TI9			External count clock input for TM9	P144/INTTI9
TI10			External count clock input for TM10	P126/TO10
TI11			External count clock input for TM11	P127/TO11
TO0	Output	Yes	Pulse signal output for TM0	P34
TO1			Pulse signal output for TM1	P35
TO2			Pulse signal output for TM2	P26/TI2
TO3			Pulse signal output for TM3	P27/TI3
TO4			Pulse signal output for TM4	P36/TI4
TO5			Pulse signal output for TM5	P37/TI5
TO6		No	Pulse signal output for TM6	P124/TI6
TO7			Pulse signal output for TM7	P125/TI7
TO80			Pulse signal output 0 for TM8	P136
TO81			Pulse signal output 1 for TM8	P137
TO10			Pulse signal output for TM10	P126/TI10
TO11			Pulse signal output for TM11	P127/TI11
TXD0	Output	Yes	Serial transmit data output for UART0 and UART1	P14/SO1
TXD1				P24/SO3
UBEN	Output	No	Higher byte enable signal output for external data bus	P91
V _{DD}	–	–	Positive power supply pin	–
V _{PP}	–	–	High voltage application pin for program write/verify	–
VSOUT	Output	No	Vsync signal output	P165
V _{SS}	–	–	Ground potential	–
WAIT	Input	No	External WAIT signal input	–
WRH	Output	No	Higher byte write strobe signal output for external data bus	P92/R \overline{W}
WRL			Lower byte write strobe signal output for external data bus	P90/LBEN

Remark PULL: On-chip pull-up resistor

(4/4)

Pin Name	I/O	PULL	Function	Alternate Function
X1	Input	No	Resonator connection for main system clock	–
X2	–			–
XT1	Input	No	Resonator connection for subsystem clock	–
XT2	–			–

Remark PULL: On-chip pull-up resistor

1.3 Pin I/O Circuits, I/O Buffer Supply, and Recommended Connection of Unused Pins

Table 1-1 shows the input/output circuit type of each pin and the recommended connection of unused pins.

For the input/output configuration of each type, refer to Figure 1-1.

Table 1-1. Types of Pin I/O Circuit and Recommended Connection of Unused Pins (1/2)

Pin	Alternate Function	I/O Circuit Type	I/O Buffer Power Supply	Recommended Connection Method
P00	NMI	5-W	V _{DD}	Input: Independently connect to V _{DD} or V _{SS} via a resistor Output: Leave open
P01 to P04	INTP0 to INTP3			
P05	INTP4/ADTRG			
P06	INTP5/RTPTRG0			
P07	INTP6			
P10	SI0/SDA0	10-F	V _{DD}	
P11	SO0	10-E		
P12	SCK0/SCL0	10-F		
P13	SI1/RXD0	5-W		
P14	SO1/TXD0	10-E		
P15	SCK1/ASCK0	10-F		
P20	SI2/SDA1	10-F	V _{DD}	
P21	SO2	10-E		
P22	SCK2/SCL1	10-F		
P23	SI3/RXD1	5-W		
P24	SO3/TXD1	10-E		
P25	SCK3/ASCK1	10-F		
P26, P27	TI2/TO2, TI3/TO3	5-W	V _{DD}	
P30, P31	TI000, TI001	5-W		
P32, P33	TI010, TI011			
P34, P35	TO0, TO1	5-A		
P36	TI4/TO4	5-W		
P37	TI5/TO5		BV _{DD}	Input: Independently connect to BV _{DD} or BV _{SS} via a resistor Output: Leave open
P40 to P47	AD0 to AD7	5		
P50 to P57	AD8 to AD15	5		
P60 to P65	A16 to A21	5		
P70 to P77	ANI0 to ANI7	9	AV _{DD}	Connect to AV _{SS}
P80 to P87	ANI8 to ANI15	9	AV _{DD}	
P90	LBEN/WRL	5	BV _{DD}	Input: Independently connect to BV _{DD} or BV _{SS} via a resistor Output: Leave open
P91	UBEN			
P92	R/W/WRH			
P93	DSTB/RD			
P94	ASTB			
P95	HLDK			
P96	HLDRQ			
P100 to P107	RTP00 to RTP07	10-E	V _{DD}	Input: Independently connect to V _{DD} or V _{SS} via a resistor Output: Leave open
P110 to P113	–	5	V _{DD}	
P120	SI4	5-K	V _{DD}	

Table 1-1. Types of Pin I/O Circuit and Recommended Connection of Unused Pins (2/2)

Pin	Alternate Function	I/O Circuit Type	I/O Buffer Power Supply	Recommended Connection Method
P121	SO4	10-G	V _{DD}	Input: Independently connect to V _{DD} or V _{SS} via a resistor Output: Leave open
P122	SCK4	10-H		
P123	CLO	5		
P124	TI6/TO6	5-K		
P125	TI7/TO7			
P126	TI10/TO10			
P127	TI11/TO11			
P130 to P133	INTCP80 to INTCP83	5-K	V _{DD}	
P134	TI8/INTTI8			
P135	TCLR8/INTTCLR8			
P136, P137	TO80, TO81	5		
P140 to P143	INTCP90 to INTCP93	5-K	V _{DD}	
P144	TI9/INTTI9			
P145	RTPTRG1			
P146, P147	–	5		
P150 to P157	RTP10 to RTP17	5	V _{DD}	
P160 to P163	PWM0 to PWM3	5	V _{DD}	
P164	CSYNCIN	5-K		
P165	VSOUT	5		
P166	HSOUT0			
P167	HSOUT1			
P170 to P177	KR0 to KR7	5-K	V _{DD}	
P180 to P187	–	5	V _{DD}	
P190 to P197	–	5	V _{DD}	
CLKOUT	–	4	BV _{DD}	Leave open
WAIT	–	1	BV _{DD}	Connect to V _{DD} via a resistor
RESET	–	2	V _{DD}	–
X1	–	–	V _{DD}	–
X2	–	–	V _{DD}	Leave open
XT1	–	–	V _{DD}	Connect to V _{SS}
XT2	–	–	V _{DD}	Leave open
AV _{REF}	–	–	–	Connect to AV _{SS}
V _{PP}	–	–	–	Connect to V _{SS}
V _{DD}	–	–	–	–
V _{SS}	–	–	–	–
AV _{DD}	–	–	–	Connect to V _{DD}
AV _{SS}	–	–	–	Connect to V _{SS}
BV _{DD}	–	–	–	Connect to V _{DD}
BV _{SS}	–	–	–	Connect to V _{SS}

Figure 1-1. Pin Input/Output Circuits (1/2)

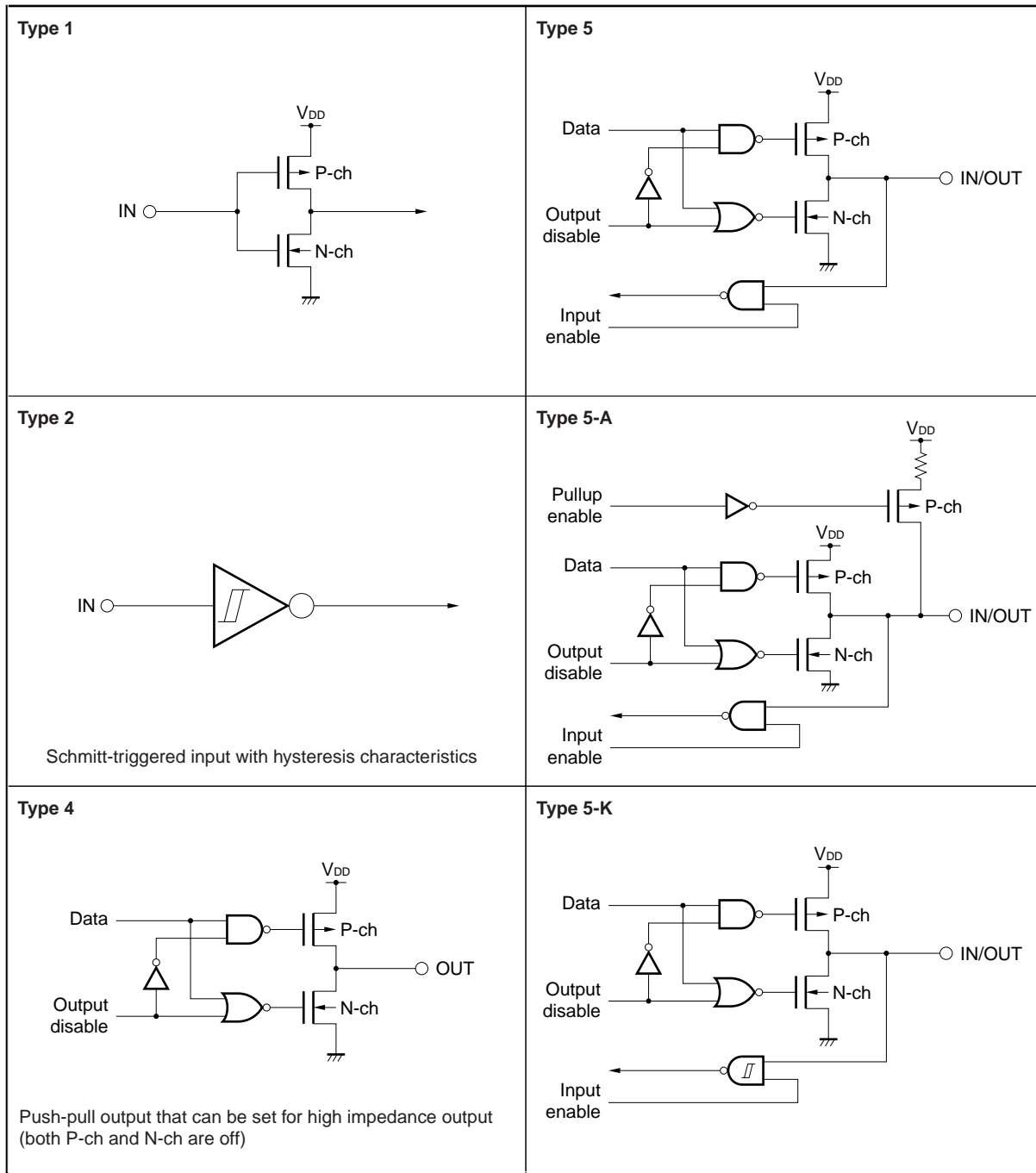
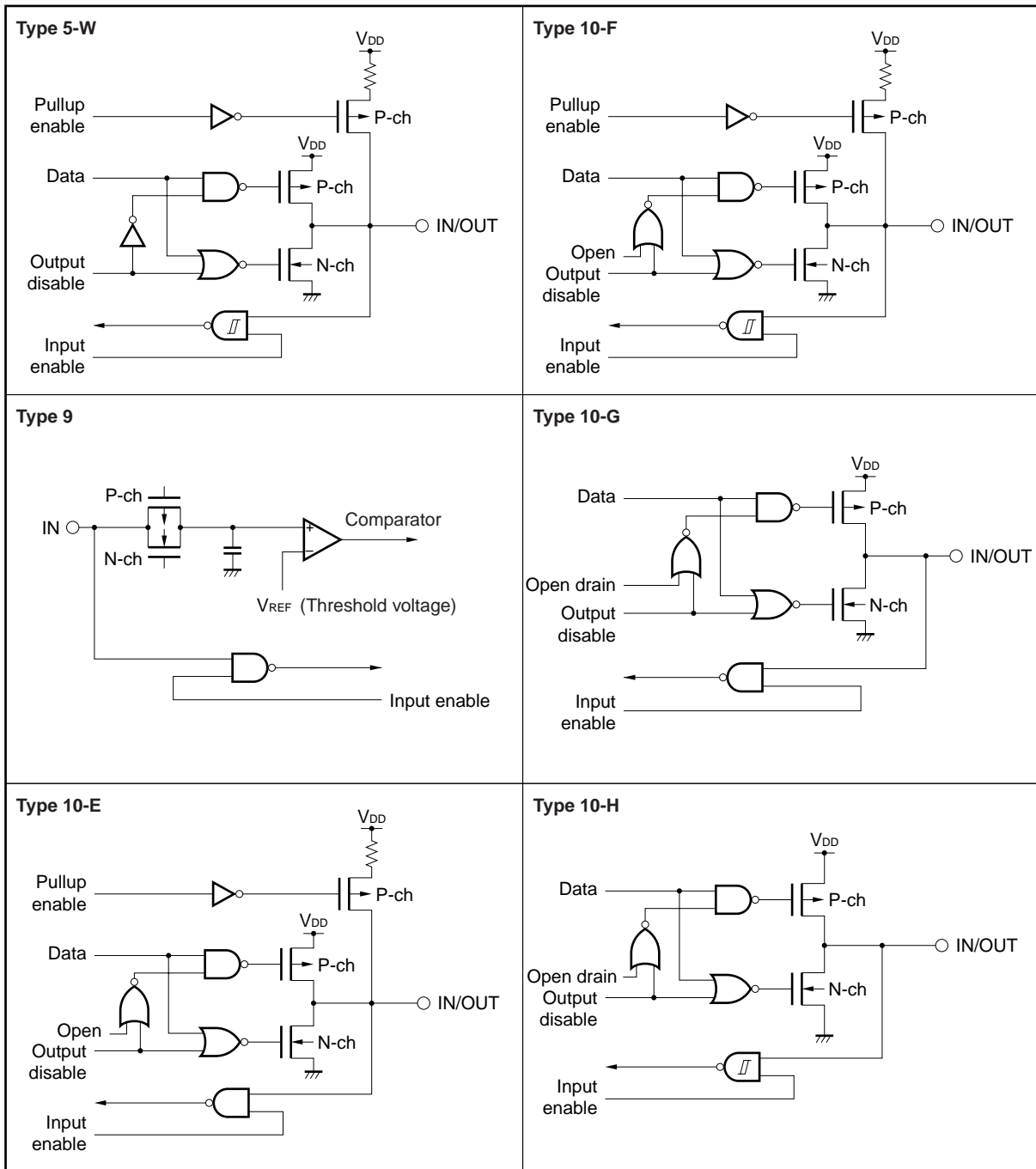

Figure 1-1. Pin Input/Output Circuits (2/2)



2. ELECTRICAL SPECIFICATIONS

Absolute Maximum Ratings (T_A = 25°C, V_{SS} = 0 V)

Parameter	Symbol	Conditions	Ratings	Unit
Supply voltage	V _{DD}		-0.5 to +4.6	V
	AV _{DD}		-0.5 to +4.6	V
	BV _{DD}		-0.5 to +4.6	V
	AV _{SS}		-0.5 to +0.5	V
	BV _{SS}		-0.5 to +0.5	V
Input voltage	V _{I1}	Note 1 (V _{DD})	-0.5 to V _{DD} + 0.5 ^{Note 4}	V
	V _{I2}	Note 2 (BV _{DD})	-0.5 to BV _{DD} + 0.5 ^{Note 4}	V
	V _{I3}	V _{PP}	-0.5 to +8.5	V
Clock input voltage	V _K	X1, XT1, V _{DD} = 2.7 to 3.6 V	-0.5 to V _{DD} + 1.0 ^{Note 4}	V
Analog input voltage	V _{IAN}	Note 3 (AV _{DD})	-0.5 to AV _{DD} + 0.5 ^{Note 4}	V
Analog reference input voltage	AV _{REF}	AV _{REF} pin	-0.5 to AV _{DD} + 0.5 ^{Note 4}	V
Output current, low	I _{OL}	Per pin	4.0	mA
		Total for P00 to P07 and P150 to P157	25	mA
		Total for P100 to P107 and P160 to P167	25	mA
		Total for P170 to P177 and P190 to P197	25	mA
		Total for P124 to P127 and P180 to P187	25	mA
		Total for P30 to P37 and P120 to P123	25	mA
		Total for P12 to P15, P20 to 27, and P110 to P113	25	mA
		Total for P50 to P57, P60 to P65, and CLKOUT	25	mA
		Total for P40 to P47 and P90 to P96	25	mA
		Total for P130 to P137 and P140 to P147	25	mA
Output current, high	I _{OH}	Per pin	-4.0	mA
		Total for P00 to P07 and P150 to P157	-25	mA
		Total for P100 to P107 and P160 to P167	-25	mA
		Total for P170 to P177 and P190 to P197	-25	mA
		Total for P124 to P127 and P180 to P187	-25	mA
		Total for P30 to P37 and P120 to P123	-25	mA
		Total for P12 to P15, P20 to 27, and P110 to P113	-25	mA
		Total for P50 to P57, P60 to P65, and CLKOUT	-25	mA
		Total for P40 to P47 and P90 to P96	-25	mA
		Total for P130 to P137 and P140 to P147	-25	mA
Output voltage	V _{O1}	Note 1 (V _{DD})	-0.5 to V _{DD} + 0.5 ^{Note 4}	V
	V _{O2}	Note 2 (BV _{DD})	-0.5 to BV _{DD} + 0.5 ^{Note 4}	V
Operating ambient temperature	T _A	Normal operation mode	-40 to +85	°C
		Flash programming mode	+10 to +40	°C
Storage temperature	T _{stg}		-40 to +125	°C

- Notes 1.** Ports 0, 1, 2, 3, 10, 11, 12, 13, 14, 15, 16, 17, 18, 19, $\overline{\text{RESET}}$ (including alternate-function pins)
- 2.** Ports 4, 5, 6, 9, $\overline{\text{WAIT}}$ (including alternate-function pins)
- 3.** Ports 7, 8 (including alternate-function pins)
- 4.** Be sure not to exceed each absolute maximum rating (MAX.).

- Cautions**
1. Avoid direct connections among the IC device output (or I/O) pins and between V_{DD} or V_{CC} and GND. However, direct connections among open-drain and open-collector pins are possible, as are direct connections to external circuits that have timing designed to prevent output contention with pins that become high-impedance.
 2. Product quality may suffer if the absolute maximum rating is exceeded even momentarily for any parameter. That is, the absolute maximum ratings are rated values at which the product is on the verge of suffering physical damage, and therefore the product must be used under conditions that ensure that the absolute maximum ratings are not exceeded.
The ratings and conditions indicated for DC characteristics and AC characteristics represent the quality assurance range during normal operation.

Capacitance (T_A = 25°C, V_{DD} = V_{SS} = 0 V)

Parameter	Symbol	Conditions	MIN.	TYP.	MAX.	Unit
Input capacitance	C _I	f _c = 1 MHz Unmeasured pins returned to 0 V			15	pF
I/O capacitance	C _{IO}				15	pF
Output capacitance	C _O				15	pF

Operating Conditions

(1) CPU Operation Frequency

Parameter	Symbol	Conditions	MIN.	TYP.	MAX.	Unit
CPU operation frequency	f _{CPU}	When main system clock is operating	0.5		16	MHz
		When subsystem clock is operating		32.768		kHz

(2) Supply Voltage

Parameter	Symbol	Conditions	MIN.	TYP.	MAX.	Unit
Supply voltage	V _{DD}		2.7		3.6	V
	AV _{DD}		2.7		3.6	V
	BV _{DD}		2.7		3.6	V

(3) Operating Frequency for Each Supply Voltage

Internal Operating Clock Frequency	Supply Voltage (V _{DD} = AV _{DD} = BV _{DD})
4 MHz ≤ f _{xx} ≤ 16 MHz	2.7 to 3.6 V
f _{XT} = 32.768 kHz	2.7 to 3.6 V

Recommended Oscillator

(1) Main System Clock Oscillator (T_A = -40 to +85°C)

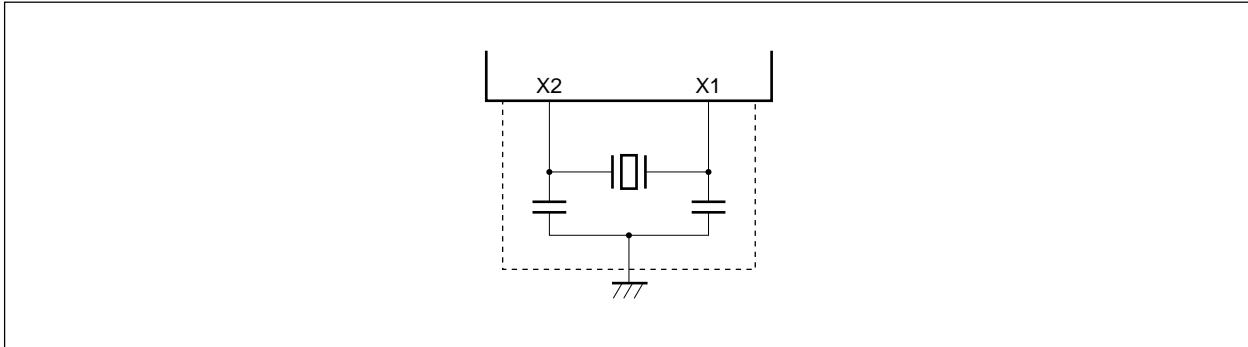

Parameter	Symbol	Conditions	MIN.	TYP.	MAX.	Unit
Oscillation frequency	f _{xx}		4		16	MHz
Oscillation stabilization time		After reset release		2 ¹⁹ /f _{xx}		s
		After STOP mode release		Note		s

Note Values vary depending on the settings of the oscillation stabilization selection register (OSTS).

- Remarks**
1. Place the oscillator as close as possible to X1 and X2.
 2. Do not wire other signal lines within the broken lines.
 3. For resonator selection and oscillation constants, customers are advised to either evaluate the oscillation themselves, or apply to the resonator manufacturer for evaluation.

(2) Subsystem Clock Oscillator (T_A = -40 to +85°C)

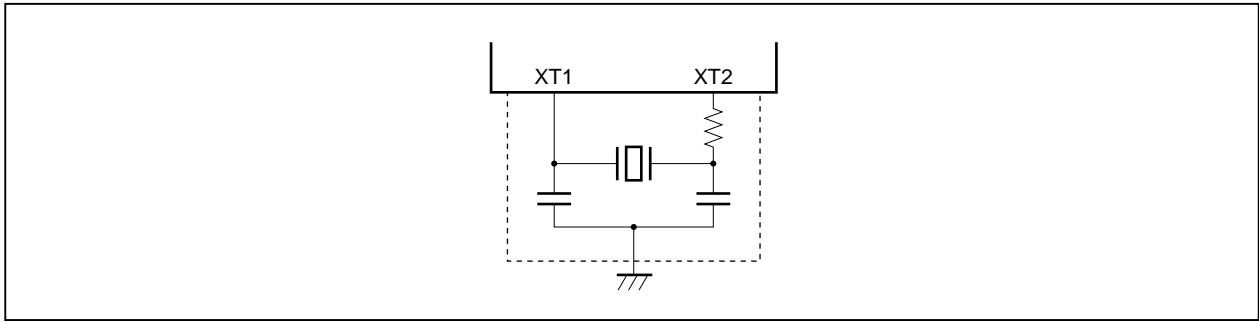

Parameter	Symbol	Conditions	MIN.	TYP.	MAX.	Unit
Oscillation frequency	f _{XT}		32	32.768	35	kHz
Oscillation stabilization time				10		s

- Remarks**
1. Place the oscillator as close as possible to XT1 and XT2.
 2. Do not wire other signal lines within the broken lines.
 3. For resonator selection and oscillation constants, customers are advised to either evaluate the oscillation themselves, or apply to the resonator manufacturer for evaluation.

DC Characteristics (T_A = -40 to +85°C, V_{DD} = AV_{DD} = BV_{DD} = 2.7 to 3.6 V, V_{SS} = AV_{SS} = BV_{SS} = 0 V)

Parameter	Symbol	Conditions	MIN.	TYP.	MAX.	Unit
Input voltage, high	V _{IH1}	Pins in Note 1 , $\overline{\text{WAIT}}$	0.7BV _{DD}		BV _{DD}	V
	V _{IH2}	Pins in Note 2	0.7V _{DD}		V _{DD}	V
	V _{IH3}	Pins in Note 3 , $\overline{\text{RESET}}$	0.75V _{DD}		V _{DD}	V
	V _{IH4}	Pins in Note 4	0.7AV _{DD}		AV _{DD}	V
	V _{IH5}	X1, XT1, XT2	0.8V _{DD}		V _{DD}	V
Input voltage, low	V _{IL1}	Pins in Note 1 , $\overline{\text{WAIT}}$	BV _{SS} - 0.5		0.3BV _{DD}	V
	V _{IL2}	Pins in Note 2	V _{SS} - 0.5		0.3V _{DD}	V
	V _{IL3}	Pins in Note 3 , $\overline{\text{RESET}}$	V _{SS} - 0.5		0.3V _{DD}	V
	V _{IL4}	Pins in Note 4	AV _{SS} - 0.5		0.3AV _{DD}	V
	V _{IL5}	X1, XT1, XT2	V _{SS}		0.2V _{DD}	V
Output voltage, high	V _{OH1}	Note 1 , CLKOUT	I _{OH} = -3 mA	0.8BV _{DD}		V
	V _{OH2}	Notes 2, 3	I _{OH} = -1 mA	0.8V _{DD}		V
Output voltage, low	V _{OL1}	Note 1 , CLKOUT			0.4	V
	V _{OL2}	Notes 2, 3 (excluding P10, 12, 20, 22)			0.4	V
	V _{OL3}	P10, 12, 20, 22			0.4	V
Input leakage current, high	I _{LIH1}	V _I = V _{DD} = AV _{DD} = BV _{DD}	Other than X1, XT1, XT2		5	μA
	I _{LIH2}		X1, XT1, XT2		20	μA
Input leakage current, low	I _{LIL1}	V _I = 0 V	Other than X1, XT1, XT2		-5	μA
	I _{LIL2}		X1, XT1, XT2		-20	μA
Output leakage current, high	I _{LOH}	V _O = V _{DD} = AV _{DD} = BV _{DD}			5	μA
Output leakage current, low	I _{LOL}	V _O = 0 V			-5	μA
Supply current	I _{DD1}	Normal operation (f _{xx} = 16 MHz)		45	65	mA
	I _{DD2}	HALT mode (f _{xx} = 16 MHz)		20	35	mA
	I _{DD3}	IDLE mode (f _{xx} = 16 MHz)		6	14	mA
	I _{DD4}	STOP mode (subsystem clock operation: f _{XT} = 32.768 kHz, watch timer operation)		13	115	μA
		STOP mode (subsystem clock stopped)		1	100	μA
Pull-up resistor	R _L		10	30	100	kΩ

- Notes 1.** Ports 4, 5, 6, 9 (including alternate-function pins)
- 2.** P11, P14, P21, P24, P34, P35, P100 to P107, P110 to P113, P121, P123, P136, P137, P146, P147, P150 to P157, P160 to P163, P165 to P167, P180 to P187, P190 to P197 (including alternate-function pins)
- 3.** P00 to P07, P10, P12, P13, P15, P20, P22, P23, P25 to P27, P30 to P33, P36, P37, P120, P122, P124 to P127, P130 to P135, P140 to P145, P164, P170 to P177 (including alternate-function pins)
- 4.** Ports 7, 8 (including alternate-function pins)

Caution The TYP. value of V_{DD} is 3.3 V. The current that is consumed at output buffers is not included.

Data Retention Characteristics (T_A = -40 to +85°C, V_{DD} = AV_{DD} = BV_{DD} = 2.7 to 3.6 V, V_{SS} = AV_{SS} = BV_{SS} = 0 V)

Parameter	Symbol	Conditions	MIN.	TYP.	MAX.	Unit
Data retention voltage	V _{DDDR}	STOP mode	1.8		3.6	V
Data retention current	I _{DDDR}	V _{DDDR} [V]		1	100	μA
Supply voltage rise time	t _{rVD}		200			μs
Supply voltage fall time	t _{fVD}		200			μs
Supply voltage hold time (from STOP mode setting)	t _{HVD}		0			ms
STOP release signal input time	t _{DREL}		0			ms
Data retention high-level input voltage	V _{IHDR}	All input ports	V _{IHn}		V _{DDDR}	V
Data retention low-level input voltage	V _{ILDR}	All input ports	0		V _{ILn}	V

Remark n = 1 to 5

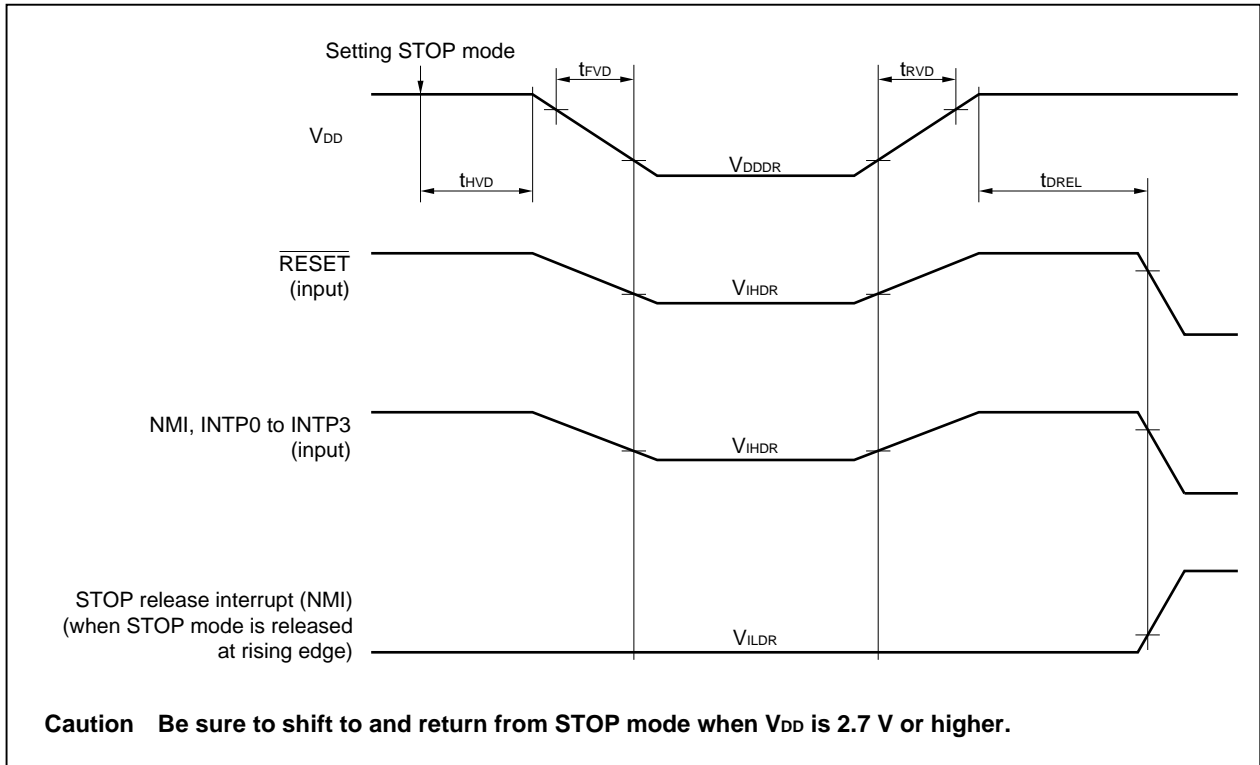

AC Characteristics

AC Test Input Waveforms (V_{DD} , BV_{DD} , AV_{DD})

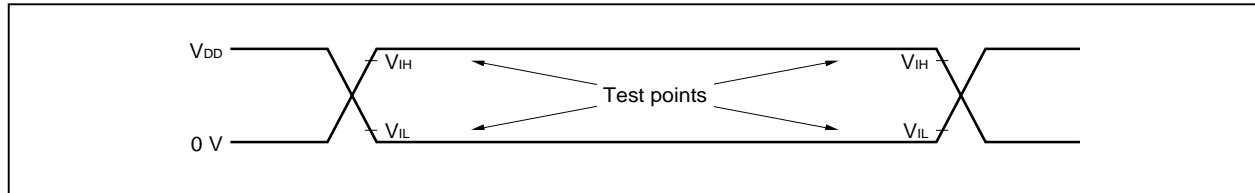

AC Test Output Test Point (BV_{DD})

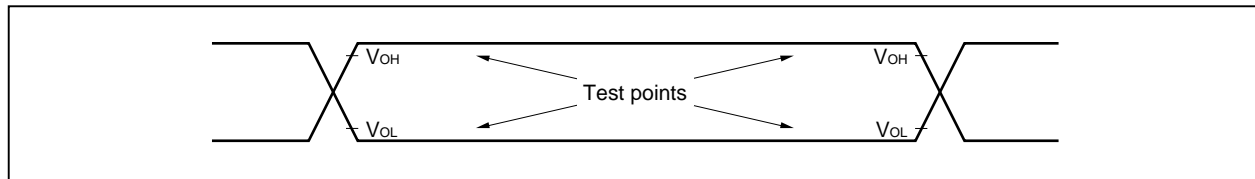

Load Conditions

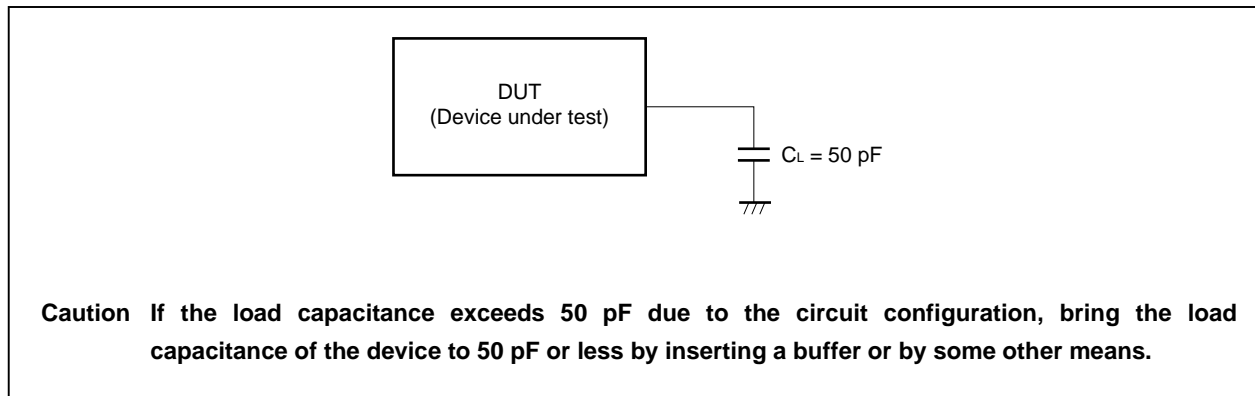

Clock Timing

Operating Condition ($T_A = -40$ to $+85^\circ\text{C}$, $V_{DD} = AV_{DD} = BV_{DD} = 2.7$ to 3.6 V, $V_{SS} = AV_{SS} = BV_{SS} = 0$ V)

Parameter	Symbol	Conditions	MIN.	MAX.	Unit
X1 input cycle	t _{cyX}	<1>	62.5	250	ns
XT1 input cycle			28.6	31.2	μs
X1 input high-level width	t _{wXH}	<2>	31.2	125	ns
XT1 input high-level width			14.3	15.6	μs
X1 input low-level width	t _{wXL}	<3>	31.2	125	ns
XT1 input low-level width			14.3	15.6	μs
X1 input rise time	t _{xR}	<4>		(<1>-<2>-<3>)/2	ns
X1 input fall time	t _{xF}	<5>		(<1>-<2>-<3>)/2	ns
CLKOUT output cycle	t _{cyK}	<6>	62.5 ns	31.2 μs	
CLKOUT high-level width	t _{wKH}	<7>	0.4 (T-20)		ns
CLKOUT low-level width	t _{wKL}	<8>	0.4 (T-20)		ns
CLKOUT rise time	t _{kR}	<9>		10	ns
CLKOUT fall time	t _{kF}	<10>		10	ns

Remark T = t_{cyK}

Clock Timing

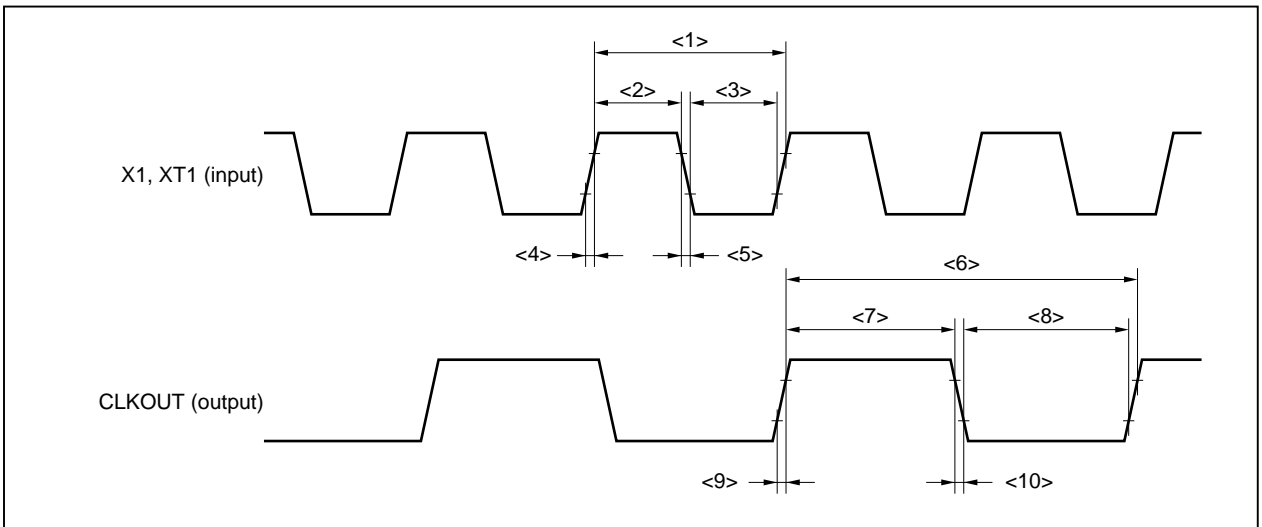

Timing of Pins Other Than X1 and CLKOUT Pins

($T_A = -40$ to $+85^\circ\text{C}$, $V_{DD} = AV_{DD} = BV_{DD} = 2.7$ to 3.6 V, $V_{SS} = AV_{SS} = BV_{SS} = 0$ V, Output Pin Load Capacitance: $C_L = 50$ pF)

Parameter	Symbol	Conditions	MIN.	MAX.	Unit
Output rise time	t _{oR}			20	ns
Output fall time	t _{oF}			20	ns

Bus Timing (CLKOUT Asynchronous)

(T_A = -40 to +85°C, V_{DD} = AV_{DD} = BV_{DD} = 2.7 to 3.6 V, V_{SS} = AV_{SS} = BV_{SS} = 0 V)

Parameter	Symbol	Conditions	MIN.	MAX.	Unit
Address setup time (to ASTB↓)	t _{SAST}	<11>	0.5T - 20		ns
Address hold time (from ASTB↓)	t _{HSTA}	<12>	0.5T - 15		ns
Address float from $\overline{\text{DSTB}}\downarrow$	t _{FDA}	<13>		2	ns
Setup time from address to data input	t _{DAID}	<14>		(2 + n)T - 30	ns
Setup time from $\overline{\text{DSTB}}\downarrow$ to data input	t _{DDID}	<15>		(1 + n)T - 30	ns
Delay time from ASTB↓ to $\overline{\text{DSTB}}\downarrow$	t _{DSTD}	<16>	0.5T - 15		ns
Data input hold time (from $\overline{\text{DSTB}}\uparrow$)	t _{HDID}	<17>	0		ns
Address output time from $\overline{\text{DSTB}}\uparrow$	t _{DDA}	<18>	(1 + i)T - 15		ns
Delay time from $\overline{\text{DSTB}}\uparrow$ to ASTB↑	t _{DDST1}	<19>	0.5T - 15		ns
Delay time from $\overline{\text{DSTB}}\uparrow$ to ASTB↓	t _{DDST2}	<20>	(1.5 + i)T - 15		ns
$\overline{\text{DSTB}}$ low-level width	t _{WDL}	<21>	(1 + n)T - 15		ns
ASTB high-level width	t _{WSTH}	<22>	T - 15		ns
Data output time from $\overline{\text{DSTB}}\downarrow$	t _{DDOD}	<23>		15	ns
Data output setup time (to $\overline{\text{DSTB}}\uparrow$)	t _{SODD}	<24>	(1 + n)T - 20		ns
Data output hold time (from $\overline{\text{DSTB}}\uparrow$)	t _{HDOD}	<25>	T - 15		ns
$\overline{\text{WAIT}}$ setup time (to address)	t _{SAWT1}	<26>	n ≥ 1	1.5T - 30	ns
	t _{SAWT2}	<27>		(1.5 + n)T - 30	ns
$\overline{\text{WAIT}}$ hold time (from address)	t _{HAWT1}	<28>	n ≥ 1	(0.5 + n)T	ns
	t _{HAWT2}	<29>		(1.5 + n)T	ns
$\overline{\text{WAIT}}$ setup time (to ASTB↓)	t _{SSTWT1}	<30>	n ≥ 1	1.5T - 25	ns
	t _{SSTWT2}	<31>		(1 + n)T - 5	ns
$\overline{\text{WAIT}}$ hold time (from ASTB↓)	t _{HSTWT1}	<32>	n ≥ 1	nT + 5	ns
	t _{HSTWT2}	<33>		(1 + n)T + 5	ns
H $\overline{\text{LDRQ}}$ high-level width	t _{WHQH}	<34>	T + 10		ns
H $\overline{\text{LDAK}}$ low-level width	t _{WHAL}	<35>	T - 15		ns
Delay time from $\overline{\text{HLDAK}}\uparrow$ to bus output	t _{DHAC}	<36>	0		ns
Delay time from $\overline{\text{HLDRQ}}\downarrow$ to $\overline{\text{HLDAK}}\downarrow$	t _{DHQA1}	<37>	1.5T	(2n + 7.5)T + 25	ns
Delay time from $\overline{\text{HLDRQ}}\uparrow$ to $\overline{\text{HLDAK}}\uparrow$	t _{DHQA2}	<38>	0.5T	1.5T + 25	ns

- Remarks**
1. T = 1/f_{CPU} (f_{CPU}: CPU operation clock frequency)
 2. n: Number of wait clocks inserted in the bus cycle.
Sampling timing changes when a programmable wait is inserted.
 3. i: Number of idle states inserted after the read cycle (0 or 1).
 4. The specifications described above are the values of when a clock with a duty ratio of 1:1 is input from X1.

Bus Timing (CLKOUT Synchronous)

($T_A = -40$ to $+85^\circ\text{C}$, $V_{DD} = AV_{DD} = BV_{DD} = 2.7$ to 3.6 V, $V_{SS} = AV_{SS} = BV_{SS} = 0$ V)

Parameter	Symbol		Conditions	MIN.	MAX.	Unit
Delay time from CLKOUT↑ to address	t _{DKA}	<39>		0	19	ns
Delay time from CLKOUT↑ to address float	t _{FKA}	<40>		-12	7	ns
Delay time from CLKOUT↓ to ASTB	t _{DKST}	<41>		-12	7	ns
Delay time from CLKOUT↑ to \overline{DSTB}	t _{DKD}	<42>		-5	14	ns
Data input setup time (to CLKOUT↑)	t _{SIDK}	<43>		15		ns
Data input hold time (from CLKOUT↑)	t _{HKID}	<44>		5		ns
Delay time from CLKOUT↑ to data output	t _{DKOD}	<45>			19	ns
\overline{WAIT} setup time (to CLKOUT↓)	t _{SWTK}	<46>		15		ns
\overline{WAIT} hold time (from CLKOUT↓)	t _{HKWT}	<47>		5		ns
\overline{HLDRQ} setup time (to CLKOUT↓)	t _{SHQK}	<48>		15		ns
\overline{HLDRQ} hold time (from CLKOUT↓)	t _{HKHQ}	<49>		5		ns
Delay time from CLKOUT↑ to address float	t _{DKF}	<50>			19	ns
Delay time from CLKOUT↑ to \overline{HLDAK}	t _{DKHA}	<51>			19	ns

Remark The specifications described above are the values of when a clock with a duty ratio of 1:1 is input from X1.

Read Cycle (CLKOUT Synchronous/Asynchronous, 1 Wait)

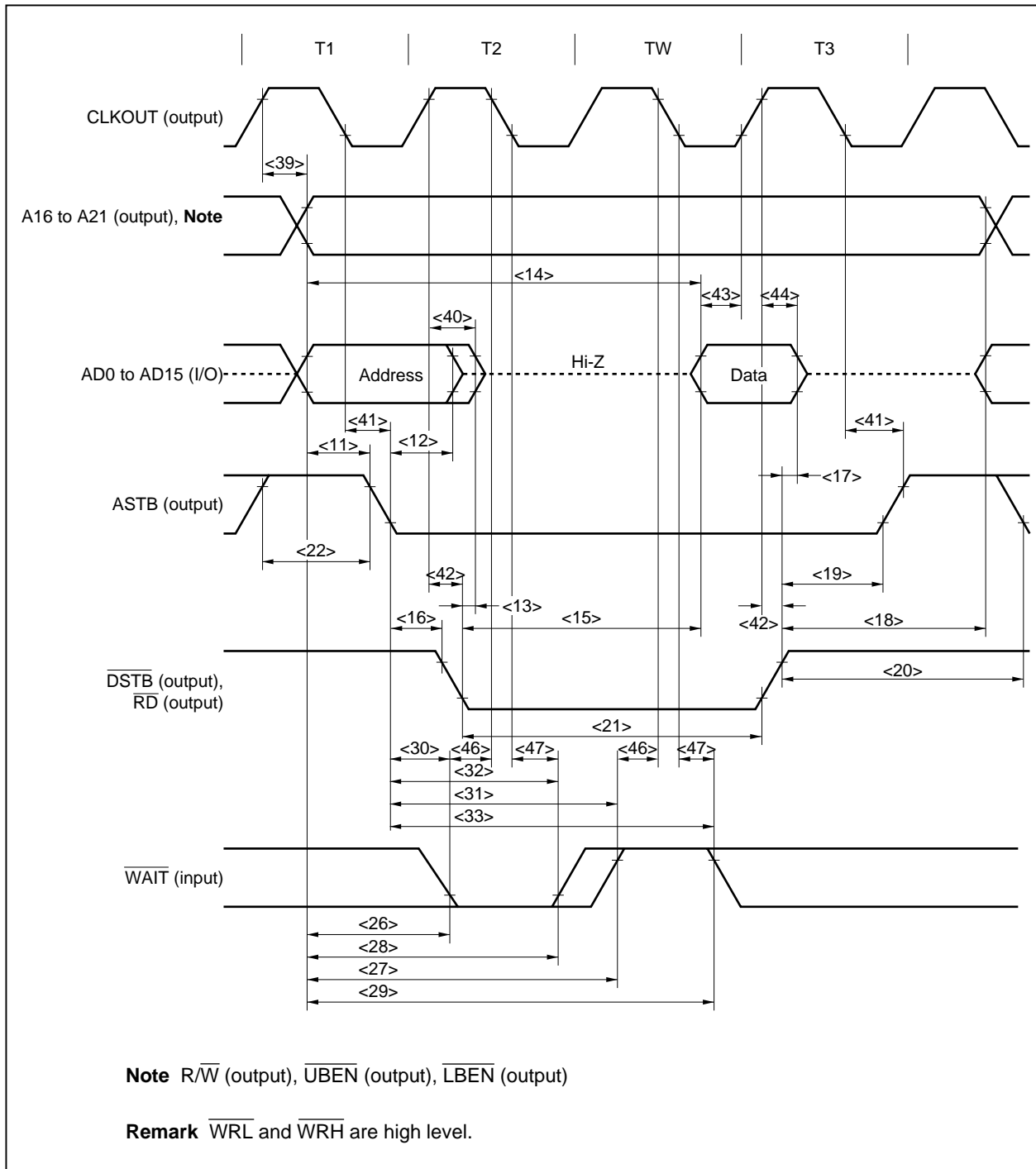

Write Cycle (CLKOUT Synchronous/Asynchronous, 1 Wait)

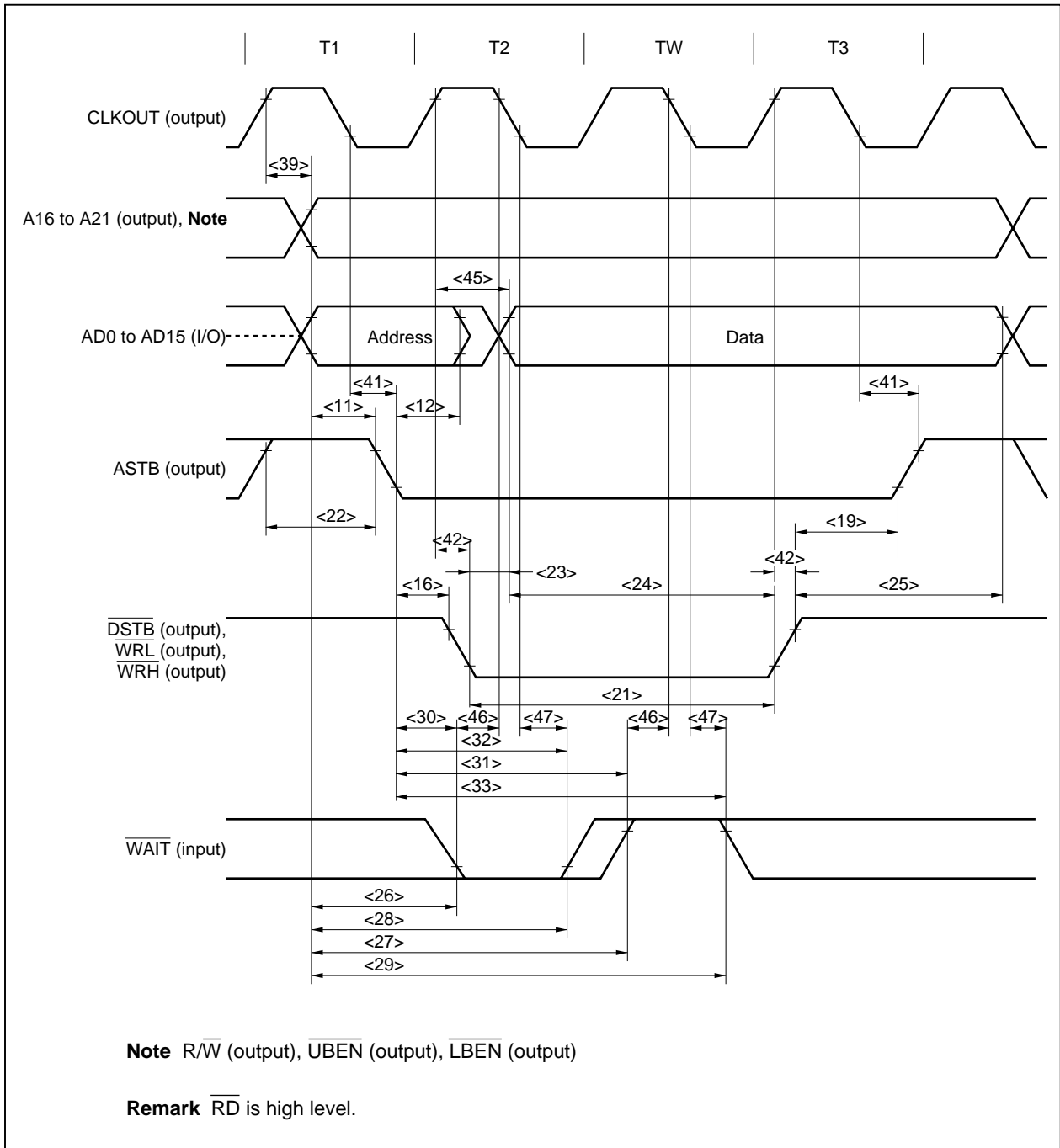

Bus Hold

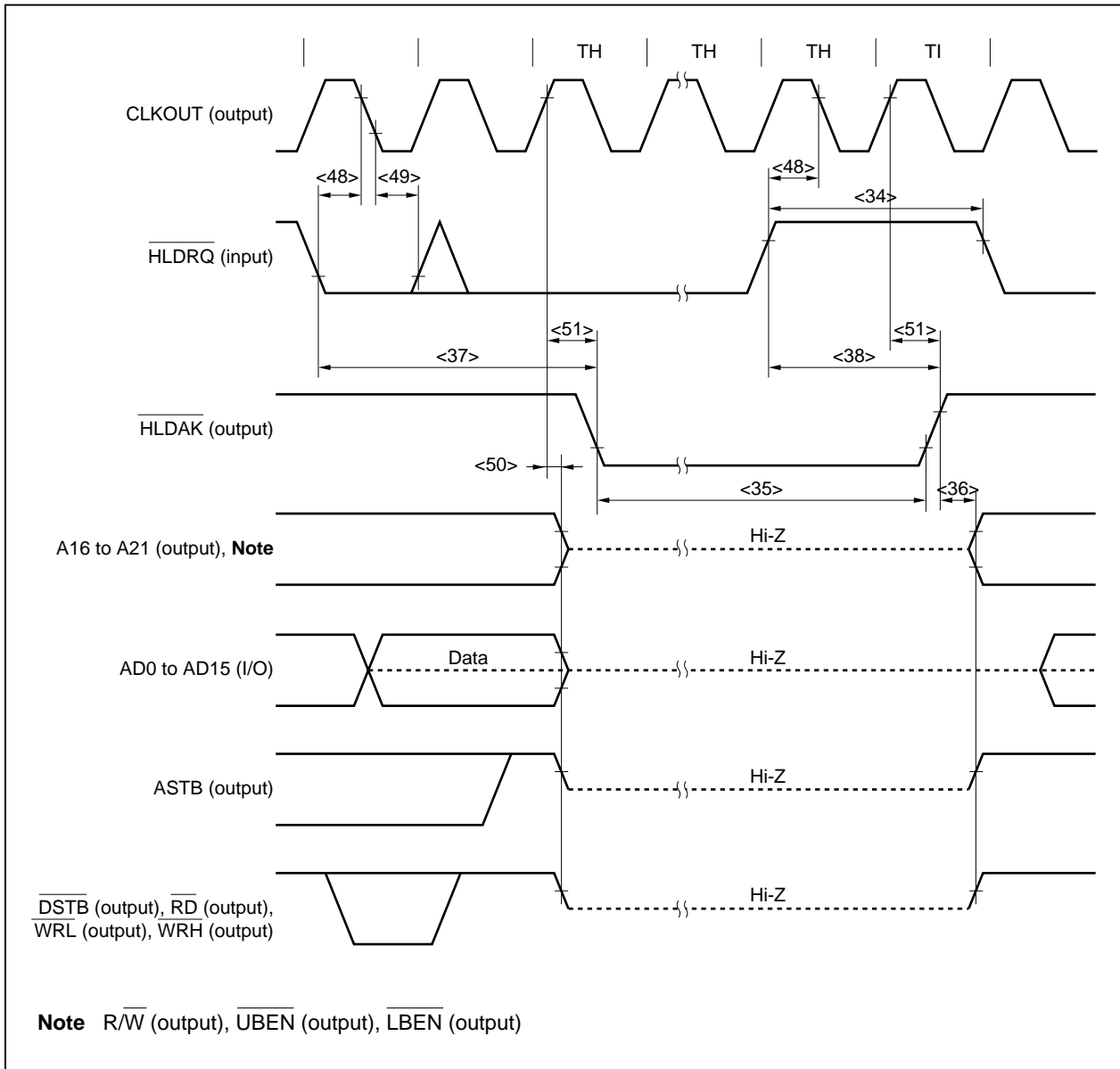

Reset/Interrupt Timing

($T_A = -40$ to $+85^\circ\text{C}$, $V_{DD} = AV_{DD} = BV_{DD} = 2.7$ to 3.6 V, $V_{SS} = AV_{SS} = BV_{SS} = 0$ V)

Parameter	Symbol	Conditions	MIN.	MAX.	Unit
RESET high-level width	t_{WRSH}	<52>	500		ns
RESET low-level width	t_{WRSL}	<53>	500		ns
NMI high-level width	t_{WNIH}	<54>	500		ns
NMI low-level width	t_{WNIL}	<55>	500		ns
INTPn high-level width	t_{WITH}	<56> n = 0 to 3, analog noise elimination	500		ns
		n = 4, 5, digital noise elimination	$3T + 20$		ns
		n = 6, digital noise elimination	$3T_{smp} + 20$		ns
INTPn low-level width	t_{WITL}	<57> n = 0 to 3, analog noise elimination	500		ns
		n = 4, 5, digital noise elimination	$3T + 20$		ns
		n = 6, digital noise elimination	$3T_{smp} + 20$		ns

Remarks 1. $T = 1/f_{xx}$

2. T_{smp} = Noise elimination sampling clock frequency

Reset

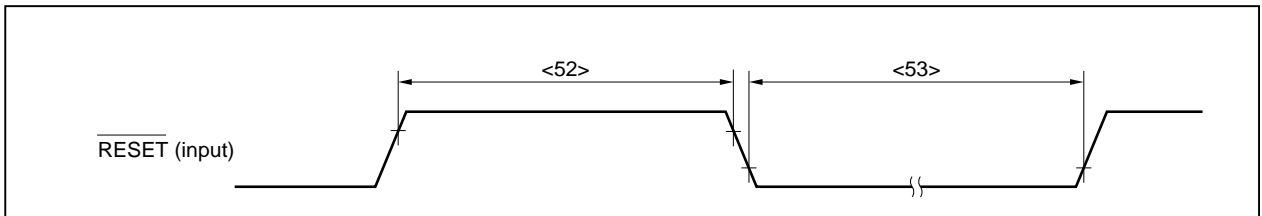

Interrupt

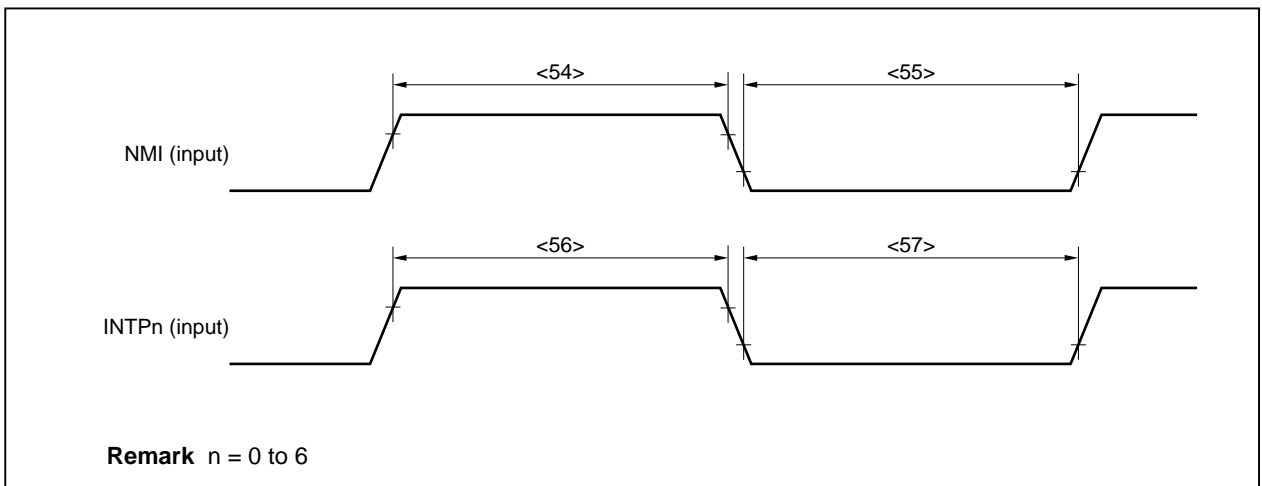

TIn Input Timing

(TA = -40 to +85°C, VDD = AVDD = BVDD = 2.7 to 3.6 V, VSS = AVSS = BVSS = 0 V)

Parameter	Symbol		Conditions	MIN.	MAX.	Unit
TIn0, TIn1 (n = 00, 01) High-level width	t _{IIH}	<58>		2T _{sam} + 20 ^{Note}		ns
TIn (n = 2 to 7, 10, 11) High-level width				3/f _{xx} + 20		ns
TIn0, TIn1 (n = 00, 01) Low-level width	t _{TIL}	<59>		2T _{sam} + 20 ^{Note}		ns
TIn (n = 2 to 7, 10, 11) Low-level width				3/f _{xx} + 20		ns

Note T_{sam} can be selected by setting the PRMn1 and PRMn0 bits of prescaler mode registers n0, n1 (PRMn0, PRMn1) (n = 0, 1).

TM0 (PRM00, PRM01 registers): T_{sam} = 2/f_{xx}, 4/f_{xx}, 16/f_{xx}, 64/f_{xx}, 256/f_{xx}, 1/INTWTI period

TM1 (PRM10, PRM11 registers): T_{sam} = 2/f_{xx}, 4/f_{xx}, 16/f_{xx}, 32/f_{xx}, 128/f_{xx}, 256/f_{xx}

However, when the TIn0 valid edge is selected as the count clock, T_{sam} = 4/f_{xx} (n = 0, 1).

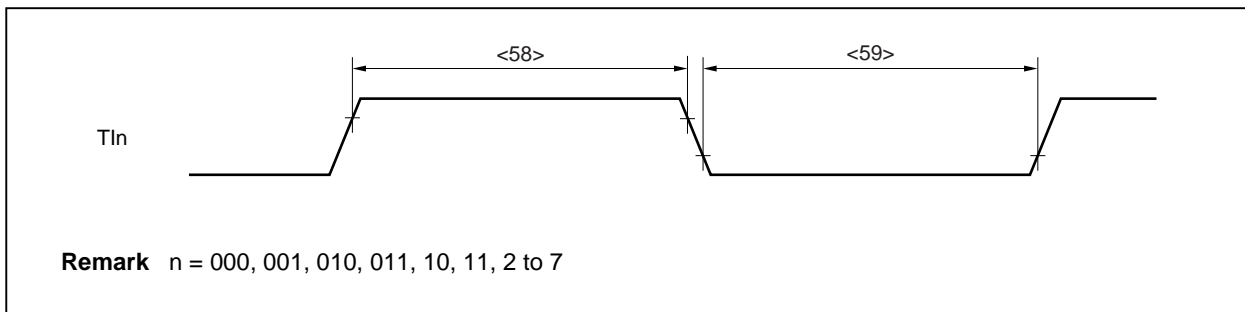

3-Wire SIO Timing

(1) Master Mode ($T_A = -40$ to $+85^\circ\text{C}$, $V_{DD} = AV_{DD} = BV_{DD} = 2.7$ to 3.6 V, $V_{SS} = AV_{SS} = BV_{SS} = 0$ V)

Parameter	Symbol		Conditions	MIN.	MAX.	Unit
$\overline{\text{SCKn}}$ cycle time	t_{KCY1}	<60>		400		ns
$\overline{\text{SCKn}}$ high-level width	t_{KH1}	<61>		140		ns
$\overline{\text{SCKn}}$ low-level width	t_{KL1}	<62>		140		ns
SIn setup time (to $\overline{\text{SCKn}}\uparrow$)	t_{SIK1}	<63>		50		ns
SIn hold time (from $\overline{\text{SCKn}}\downarrow$)	t_{KSI1}	<64>		50		ns
Delay time from $\overline{\text{SCKn}}\downarrow$ to SOn output	t_{KSO1}	<65>			60	ns

Remark n = 0 to 3

(2) Slave Mode ($T_A = -40$ to $+85^\circ\text{C}$, $V_{DD} = AV_{DD} = BV_{DD} = 2.7$ to 3.6 V, $V_{SS} = AV_{SS} = BV_{SS} = 0$ V)

Parameter	Symbol		Conditions	MIN.	MAX.	Unit
$\overline{\text{SCKn}}$ cycle time	t_{KCY2}	<60>		400		ns
$\overline{\text{SCKn}}$ high-level width	t_{KH2}	<61>		140		ns
$\overline{\text{SCKn}}$ low-level width	t_{KL2}	<62>		140		ns
SIn setup time (to $\overline{\text{SCKn}}\uparrow$)	t_{SIK2}	<63>		50		ns
SIn hold time (from $\overline{\text{SCKn}}\downarrow$)	t_{KSI2}	<64>		50		ns
Delay time from $\overline{\text{SCKn}}\downarrow$ to SOn output	t_{KSO2}	<65>			60	ns

Remark n = 0 to 3

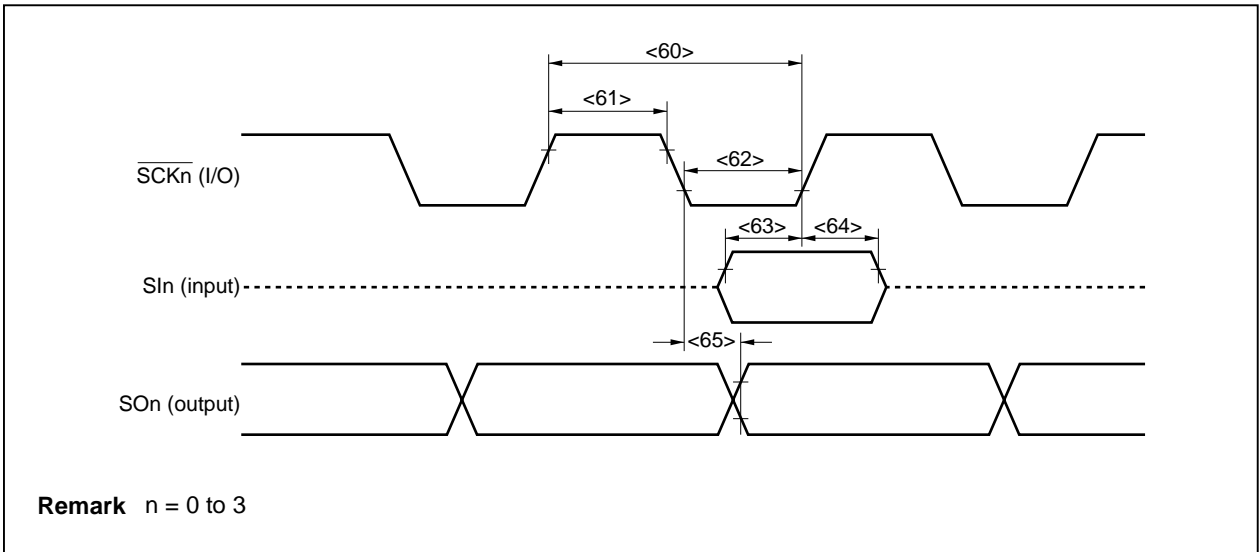

Remark n = 0 to 3

3-Wire Variable-Length CSI Timing

(1) Master Mode ($T_A = -40$ to $+85^\circ\text{C}$, $V_{DD} = AV_{DD} = BV_{DD} = 2.7$ to 3.6 V, $V_{SS} = AV_{SS} = BV_{SS} = 0$ V)

Parameter	Symbol	Conditions	MIN.	MAX.	Unit
SCK4 cycle time	t_{kCY1}	<66>	400		ns
SCK4 high-level width	t_{kH1}	<67>	140		ns
SCK4 low-level width	t_{kL1}	<68>	140		ns
SI4 setup time (to SCK4↑)	t_{sIK1}	<69>	50		ns
SI4 hold time (from SCK4↑)	t_{kSI1}	<70>	50		ns
Delay time from SCK4↓ to SO4 output	t_{kSO1}	<71>		60	ns

(2) Slave Mode ($T_A = -40$ to $+85^\circ\text{C}$, $V_{DD} = AV_{DD} = BV_{DD} = 2.7$ to 3.6 V, $V_{SS} = AV_{SS} = BV_{SS} = 0$ V)

Parameter	Symbol	Conditions	MIN.	MAX.	Unit
SCK4 cycle time	t_{kCY2}	<66>	400		ns
SCK4 high-level width	t_{kH2}	<67>	140		ns
SCK4 low-level width	t_{kL2}	<68>	140		ns
SI4 setup time (to SCK4↑)	t_{sIK2}	<69>	50		ns
SI4 hold time (from SCK4↑)	t_{kSI2}	<70>	50		ns
Delay time from SCK4↓ to SO4 output	t_{kSO2}	<71>		60	ns

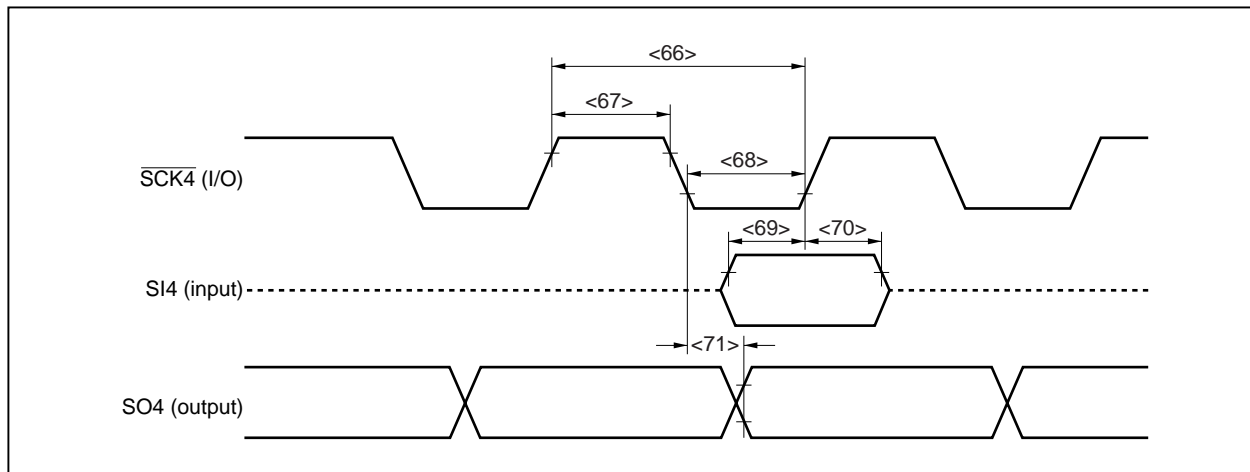

UART Timing ($T_A = -40$ to $+85^\circ\text{C}$, $V_{DD} = AV_{DD} = BV_{DD} = 2.7$ to 3.6 V, $V_{SS} = AV_{SS} = BV_{SS} = 0$ V)

Parameter	Symbol	Conditions	MIN.	MAX.	Unit
ASCKn cycle time	t_{KY13}	<72>	200		ns
ASCKn high-level width	t_{KH13}	<73>	80		ns
ASCKn low-level width	t_{KL13}	<74>	80		ns

Remark n = 0, 1

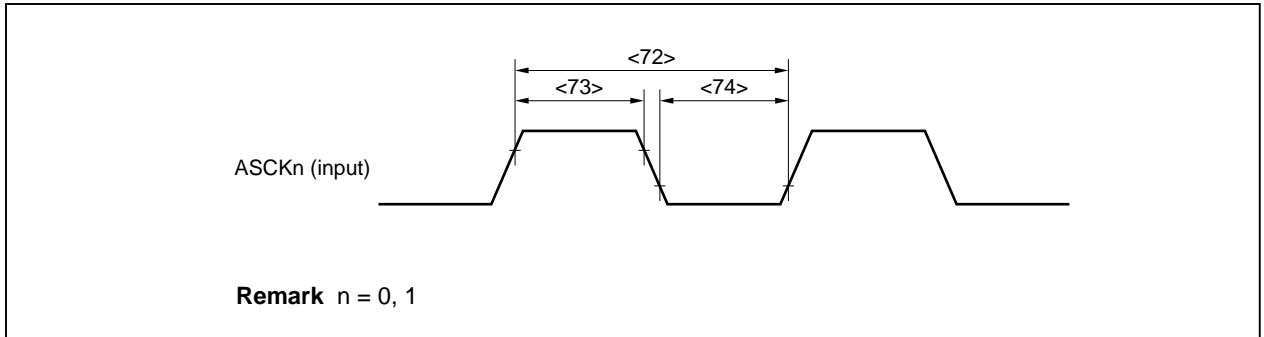

I²C Bus Mode (Only for μPD70F3040Y)

(T_A = -40 to +85°C, V_{DD} = AV_{DD} = BV_{DD} = 2.7 to 3.6 V, V_{SS} = AV_{SS} = BV_{SS} = 0 V)

Parameter		Symbol		Standard Mode		High-Speed Mode		Unit
				MIN.	MAX.	MIN.	MAX.	
SCLn clock frequency		f _{CLK}		0	100	0	400	kHz
Bus free time (between stop/start conditions)		t _{BUF}	<75>	4.7	–	1.3	–	μs
Hold time ^{Note 1}		t _{HD : STA}	<76>	4.0	–	0.6	–	μs
SCLn clock low-level width		t _{LOW}	<77>	4.7	–	1.3	–	μs
SCLn clock high-level width		t _{HIGH}	<78>	4.0	–	0.6	–	μs
Setup time of start/restart conditions		t _{SU : STA}	<79>	4.7	–	0.6	–	μs
Data hold time	CBUS-compatible master	t _{HD : DAT}	<80>	5.0	–	–	–	μs
	I ² C mode			0 ^{Note 2}	–	0 ^{Note 2}	0.9 ^{Note 3}	μs
Data setup time		t _{SU : DAT}	<81>	250	–	100 ^{Note 4}	–	ns
Rising time of SDAn and SCLn signals		t _R	<82>	–	1000	20 + 0.1Cb ^{Note 5}	300	ns
Falling time of SDAn and SCLn signals		t _F	<83>	–	300	20 + 0.1Cb ^{Note 5}	300	ns
Setup time of stop condition		t _{SU : STO}	<84>	4.0	–	0.6	–	μs
Pulse width of spike suppressed by input filter		t _{SP}	<85>	–	–	0	50	ns
Load capacitance of bus line		Cb		–	400	–	400	pF

- Notes**
- The first clock pulse in the start condition is generated after the hold time.
 - The system must internally provide at least 300-ns hold time for the SDAn signal (at V_{IHmin.} of the SCLn signal) in order to fill the undefined period that appears at the SCLn falling edge.
 - If the system does not extend the low hold time (t_{LOW}), it is required to satisfy only the maximum data hold time (t_{HD : DAT}).
 - The high-speed I²C bus is available in the standard mode I²C bus system. In this case, following conditions should be satisfied.
 - When the system does not extend the low-state hold time of the SCLn signal
t_{SU : DAT} ≥ 250 ns
 - When the system extends the low-state hold time of the SCLn signal
Before the SCLn line is released (t_{Rmax.} + t_{SU : DAT} = 1000 + 250 = 1250 ns: Standard mode I²C bus specification), send the next data bit to the SDAn line.
 - Cb: Total capacitance of one bus line (Unit: pF)

Remark n = 0, 1

I²C Bus Mode (μPD70F3040Y only)

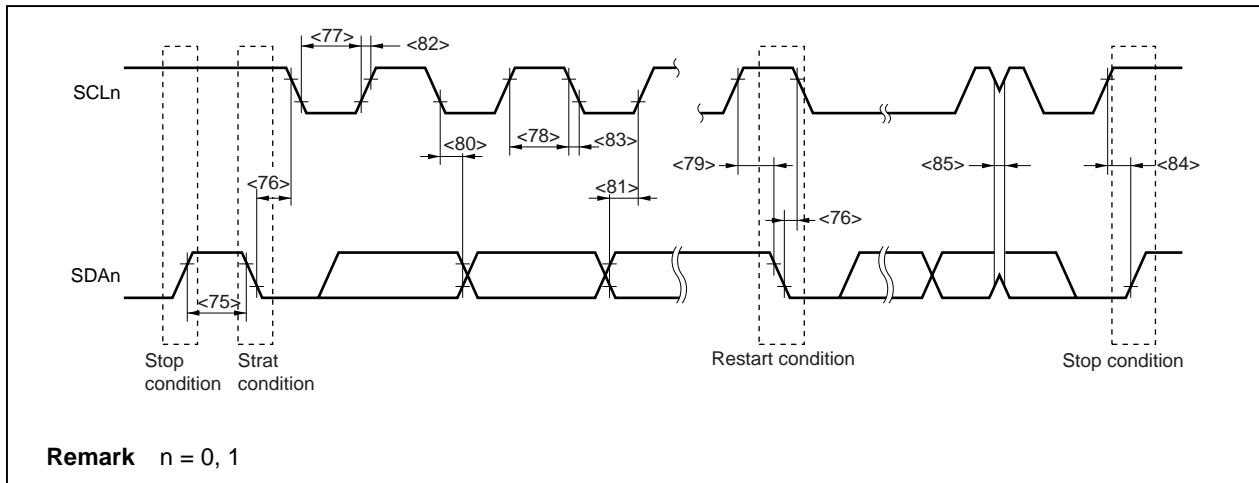

A/D Converter (T_A = -40 to +85°C, V_{DD} = AV_{DD} = AV_{REF} = 2.7 to 3.6 V, AV_{SS} = V_{SS} = 0 V, Output Pin Load Capacitance: C_L = 50 pF)

Parameter	Symbol	Conditions	MIN.	TYP.	MAX.	Unit
Resolution			10	10	10	bit
Overall error ^{Note 1}					±0.8	%FSR
Conversion time	t _{CONV}		5		100	μs
Zero-scale error ^{Note 1}					±0.4	%FSR
Full-scale error ^{Note 1}					±0.4	%FSR
Integral linearity error ^{Note 2}					±4.0	LSB
Differential linearity error ^{Note 2}					±4.0	LSB
Analog reference voltage	AV _{REF}	AV _{REF} = AV _{DD}	2.7		3.6	V
Analog input voltage	V _{IAN}		AV _{SS}		AV _{REF}	V
AV _{REF} current	I _{REF}			240	360	μA
Supply current	I _{DD}			1	3	mA

- Notes**
1. Excluding quantization error (±0.05%FSR)
 2. Excluding quantization error (±0.5LSB)

Remark LSB: Least Significant Bit
FSR: Full Scale Range

Flash Memory Programming Mode

Write/Erase Characteristics (T_A = 10 to 40°C, V_{DD} = 3.0 to 3.6 V)

Parameter	Symbol	Conditions	MIN.	TYP.	MAX.	Unit	
Write current	I _{DDW}	When V _{PP} = V _{PP1}	V _{DD} pin			67	mA
	I _{PPW}		V _{PP} pin			100	mA
Erase current	I _{DDE}	When V _{PP} = V _{PP1}	V _{DD} pin			67	mA
	I _{PPE}		V _{PP} pin			200	mA
Unit erase time	t _{ER}		0.2	0.2	0.2	s	
Total erase time	t _{ERT}				20	s	
Rewrite count ^{Note}			20	20	20	times	
V _{PP} supply voltage	V _{PP0}	In normal operation mode	0		0.2V _{DD}	V	
	V _{PP1}	In flash memory programming mode	7.5	7.8	8.1	V	
Operation frequency			4		16	MHz	

Note Write/erase is regarded as 1 cycle.

3. PACKAGE DRAWING

176-PIN PLASTIC LQFP (FINE PITCH) (24x24)

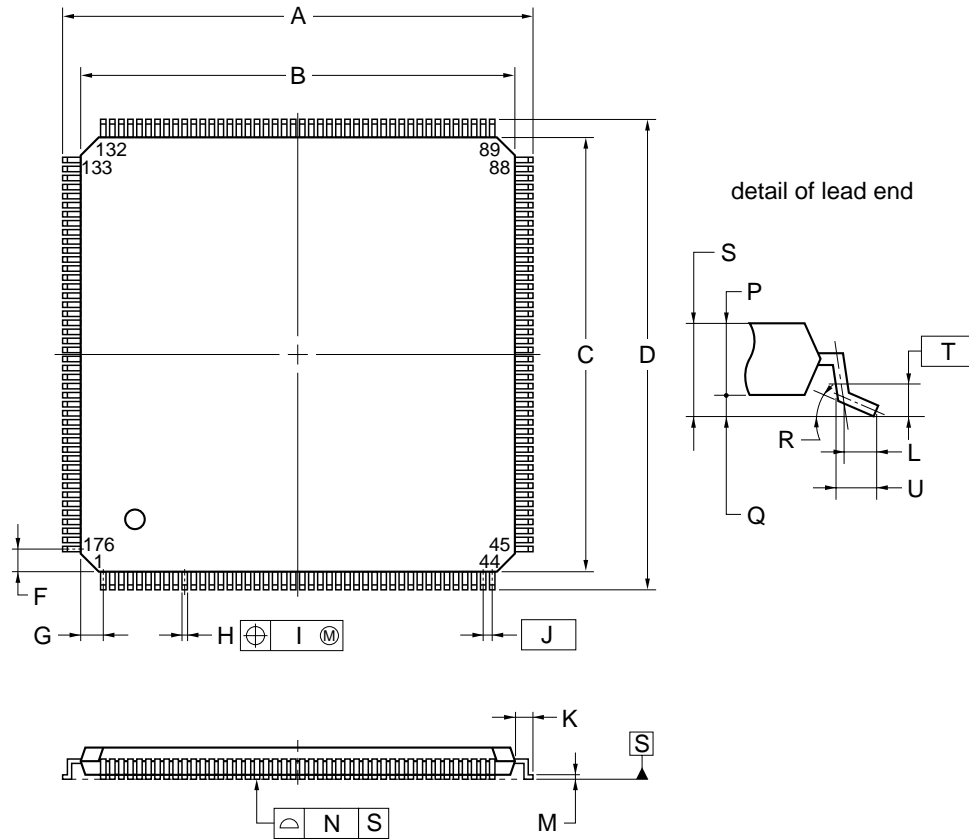

NOTE
 Each lead centerline is located within 0.10 mm of its true position (T.P.) at maximum material condition.

ITEM	MILLIMETERS
A	26.0±0.2
B	24.0±0.2
C	24.0±0.2
D	26.0±0.2
F	1.25
G	1.25
H	0.22±0.05
I	0.08
J	0.5 (T.P.)
K	1.0±0.2
L	0.5
M	0.17 ^{+0.03} _{-0.07}
N	0.08
P	1.4
Q	0.1±0.05
R	3° ^{+4°} _{-3°}
S	1.5±0.1

S176GM-50-UEU

4. RECOMMENDED SOLDERING CONDITIONS

T.B.D.

[MEMO]

NOTES FOR CMOS DEVICES

① PRECAUTION AGAINST ESD FOR SEMICONDUCTORS

Note:

Strong electric field, when exposed to a MOS device, can cause destruction of the gate oxide and ultimately degrade the device operation. Steps must be taken to stop generation of static electricity as much as possible, and quickly dissipate it once, when it has occurred. Environmental control must be adequate. When it is dry, humidifier should be used. It is recommended to avoid using insulators that easily build static electricity. Semiconductor devices must be stored and transported in an anti-static container, static shielding bag or conductive material. All test and measurement tools including work bench and floor should be grounded. The operator should be grounded using wrist strap. Semiconductor devices must not be touched with bare hands. Similar precautions need to be taken for PW boards with semiconductor devices on it.

② HANDLING OF UNUSED INPUT PINS FOR CMOS

Note:

No connection for CMOS device inputs can be cause of malfunction. If no connection is provided to the input pins, it is possible that an internal input level may be generated due to noise, etc., hence causing malfunction. CMOS devices behave differently than Bipolar or NMOS devices. Input levels of CMOS devices must be fixed high or low by using a pull-up or pull-down circuitry. Each unused pin should be connected to V_{DD} or GND with a resistor, if it is considered to have a possibility of being an output pin. All handling related to the unused pins must be judged device by device and related specifications governing the devices.

③ STATUS BEFORE INITIALIZATION OF MOS DEVICES

Note:

Power-on does not necessarily define initial status of MOS device. Production process of MOS does not define the initial operation status of the device. Immediately after the power source is turned ON, the devices with reset function have not yet been initialized. Hence, power-on does not guarantee out-pin levels, I/O settings or contents of registers. Device is not initialized until the reset signal is received. Reset operation must be executed immediately after power-on for devices having reset function.

Purchase of NEC I²C components conveys a license under the Philips I²C Patent Rights to use these components in an I²C system, provided that the system conforms to the I²C Standard Specification as defined by Philips.

Related document μ PD703039, 703039Y, 703040, 703040Y, 703041, 703041Y Data Sheet (U13953E)

Reference document Electrical Characteristics for Microcomputer (IEI-601)^{Note}

Note This document number is that of the Japanese version.

The documents indicated in this publication may include preliminary versions. However, preliminary versions are not marked as such.

V850 Family and V850/SV1 are trademarks of NEC Corporation.

Regional Information

Some information contained in this document may vary from country to country. Before using any NEC product in your application, please contact the NEC office in your country to obtain a list of authorized representatives and distributors. They will verify:

- Device availability
- Ordering information
- Product release schedule
- Availability of related technical literature
- Development environment specifications (for example, specifications for third-party tools and components, host computers, power plugs, AC supply voltages, and so forth)
- Network requirements

In addition, trademarks, registered trademarks, export restrictions, and other legal issues may also vary from country to country.

NEC Electronics Inc. (U.S.)

Santa Clara, California
 Tel: 408-588-6000
 800-366-9782
 Fax: 408-588-6130
 800-729-9288

NEC Electronics (Germany) GmbH

Duesseldorf, Germany
 Tel: 0211-65 03 02
 Fax: 0211-65 03 490

NEC Electronics (UK) Ltd.

Milton Keynes, UK
 Tel: 01908-691-133
 Fax: 01908-670-290

NEC Electronics Italiana s.r.l.

Milano, Italy
 Tel: 02-66 75 41
 Fax: 02-66 75 42 99

NEC Electronics (Germany) GmbH

Benelux Office
 Eindhoven, The Netherlands
 Tel: 040-2445845
 Fax: 040-2444580

NEC Electronics (France) S.A.

Velizy-Villacoublay, France
 Tel: 01-30-67 58 00
 Fax: 01-30-67 58 99

NEC Electronics (France) S.A.

Spain Office
 Madrid, Spain
 Tel: 91-504-2787
 Fax: 91-504-2860

NEC Electronics (Germany) GmbH

Scandinavia Office
 Taebby, Sweden
 Tel: 08-63 80 820
 Fax: 08-63 80 388

NEC Electronics Hong Kong Ltd.

Hong Kong
 Tel: 2886-9318
 Fax: 2886-9022/9044

NEC Electronics Hong Kong Ltd.

Seoul Branch
 Seoul, Korea
 Tel: 02-528-0303
 Fax: 02-528-4411

NEC Electronics Singapore Pte. Ltd.

United Square, Singapore 1130
 Tel: 65-253-8311
 Fax: 65-250-3583

NEC Electronics Taiwan Ltd.

Taipei, Taiwan
 Tel: 02-2719-2377
 Fax: 02-2719-5951

NEC do Brasil S.A.

Electron Devices Division
 Rodovia Presidente Dutra, Km 214
 07210-902-Guarulhos-SP Brasil
 Tel: 55-11-6465-6810
 Fax: 55-11-6465-6829

J99.1

- **The information contained in this document is being issued in advance of the production cycle for the device. The parameters for the device may change before final production or NEC Corporation, at its own discretion, may withdraw the device prior to its production.**
 - No part of this document may be copied or reproduced in any form or by any means without the prior written consent of NEC Corporation. NEC Corporation assumes no responsibility for any errors which may appear in this document.
 - NEC Corporation does not assume any liability for infringement of patents, copyrights or other intellectual property rights of third parties by or arising from use of a device described herein or any other liability arising from use of such device. No license, either express, implied or otherwise, is granted under any patents, copyrights or other intellectual property rights of NEC Corporation or others.
 - Descriptions of circuits, software, and other related information in this document are provided for illustrative purposes in semiconductor product operation and application examples. The incorporation of these circuits, software, and information in the design of the customer's equipment shall be done under the full responsibility of the customer. NEC Corporation assumes no responsibility for any losses incurred by the customer or third parties arising from the use of these circuits, software, and information.
 - While NEC Corporation has been making continuous effort to enhance the reliability of its semiconductor devices, the possibility of defects cannot be eliminated entirely. To minimize risks of damage or injury to persons or property arising from a defect in an NEC semiconductor device, customers must incorporate sufficient safety measures in its design, such as redundancy, fire-containment, and anti-failure features.
 - NEC devices are classified into the following three quality grades:
"Standard", "Special", and "Specific". The Specific quality grade applies only to devices developed based on a customer designated "quality assurance program" for a specific application. The recommended applications of a device depend on its quality grade, as indicated below. Customers must check the quality grade of each device before using it in a particular application.
 - Standard: Computers, office equipment, communications equipment, test and measurement equipment, audio and visual equipment, home electronic appliances, machine tools, personal electronic equipment and industrial robots
 - Special: Transportation equipment (automobiles, trains, ships, etc.), traffic control systems, anti-disaster systems, anti-crime systems, safety equipment and medical equipment (not specifically designed for life support)
 - Specific: Aircraft, aerospace equipment, submersible repeaters, nuclear reactor control systems, life support systems or medical equipment for life support, etc.
- The quality grade of NEC devices is "Standard" unless otherwise specified in NEC's Data Sheets or Data Books. If customers intend to use NEC devices for applications other than those specified for Standard quality grade, they should contact an NEC sales representative in advance.